

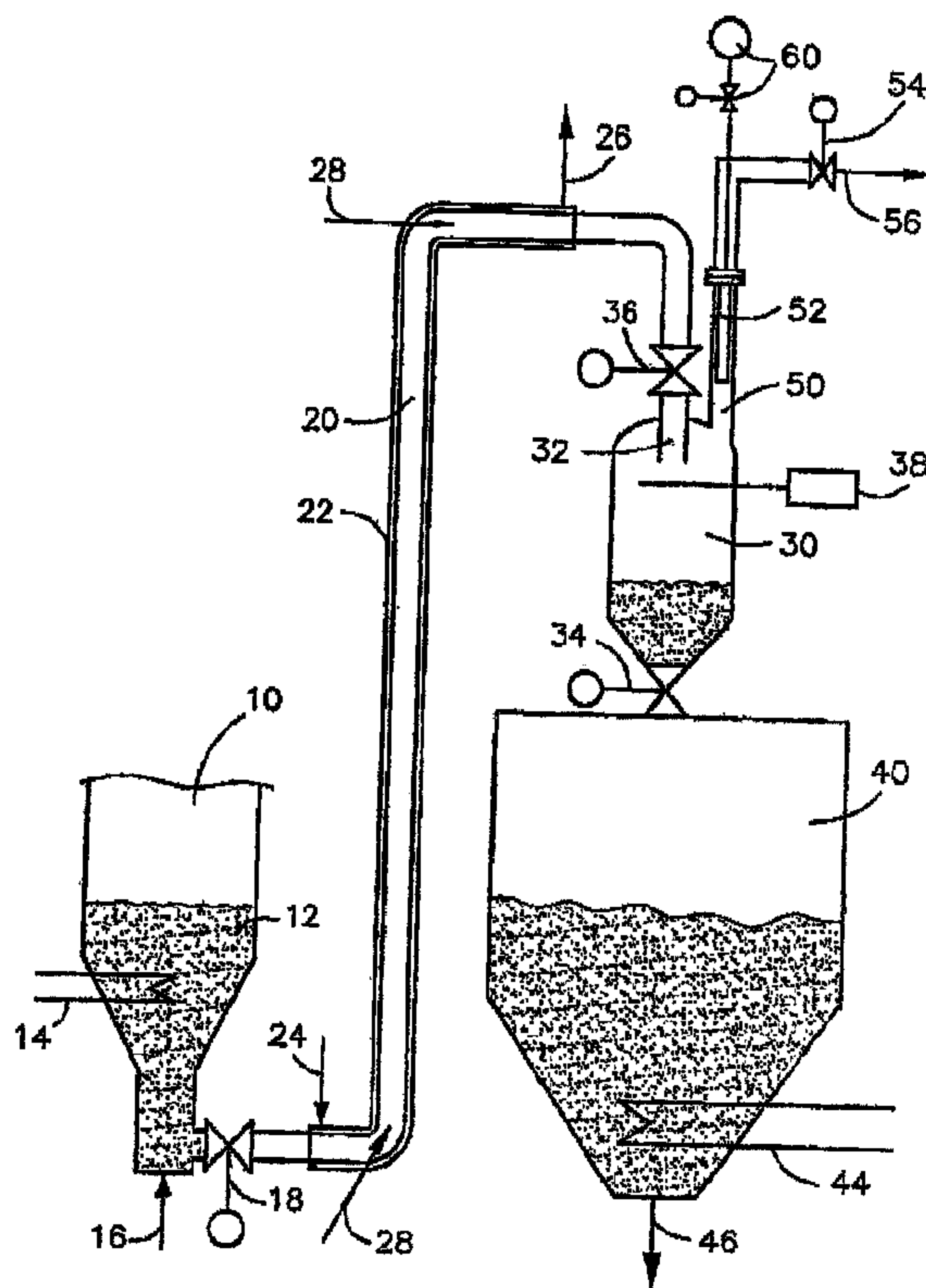

(86) Date de dépôt PCT/PCT Filing Date: 2000/06/19  
 (87) Date publication PCT/PCT Publication Date: 2001/01/04  
 (45) Date de délivrance/Issue Date: 2006/10/17  
 (85) Entrée phase nationale/National Entry: 2001/12/21  
 (86) N° demande PCT/PCT Application No.: FI 2000/000546  
 (87) N° publication PCT/PCT Publication No.: 2001/000313  
 (30) Priorité/Priority: 1999/06/28 (FI991459)

(51) Cl.Int./Int.Cl. *B01J 3/02* (2006.01),  
*B01J 8/00* (2006.01), *B01J 8/18* (2006.01),  
*F23C 10/10* (2006.01), *F23C 10/16* (2006.01),  
*F23C 10/24* (2006.01), *F23J 3/02* (2006.01)  
 (72) Inventeurs/Inventors:  
 ERIKSSON, TIMO, FI;  
 ISAKSSON, JUHANI, FI;  
 KUIVALAINEN, REIJO, FI;  
 LEHTONEN, PEKKA, FI;  
 PALONEN, JUHA, FI  
 (73) Propriétaire/Owner:  
 FOSTER WHEELER ENERGIA OY, FI  
 (74) Agent: GOWLING LAFLEUR HENDERSON LLP

(54) Titre : PROCÉDE ET DISPOSITIF POUR LE TRAITEMENT DE MATERIAU PARTICULAIRE A HAUTE PRESSION  
 (54) Title: METHOD AND APPARATUS FOR TREATING HIGH PRESSURE PARTICULATE MATERIAL



(57) Abrégé/Abstract:

A method and an apparatus for conveying particulate material of a reactor pneumatically from a high pressure delivery vessel (10) to a receiving vessel (40) at a lower pressure using gas discharging from the reactor as a carrier gas, by using an apparatus comprising a conveyor line (20) and a collecting vessel (30), which collecting vessel comprises means (50) to discharge carrier gas and means (54) to control the flow rate of the carrier gas, in which the pressure in the collecting vessel is controlled in such a way that the material has almost the same pressure as the delivery vessel when conveyed to the collecting vessel, from which it is transferred to the receiving vessel essentially at the same pressure as the receiving vessel.

## (12) INTERNATIONAL APPLICATION PUBLISHED UNDER THE PATENT COOPERATION TREATY (PCT)

(19) World Intellectual Property Organization  
International Bureau(43) International Publication Date  
4 January 2001 (04.01.2001)

PCT

(10) International Publication Number  
**WO 01/00313 A1**(51) International Patent Classification<sup>7</sup>: **B01J 3/02,**  
F23C 10/16, 10/24

(21) International Application Number: PCT/FI00/00546

(22) International Filing Date: 19 June 2000 (19.06.2000)

(25) Filing Language: English

(26) Publication Language: English

(30) Priority Data:  
991459 28 June 1999 (28.06.1999) FI(71) Applicant (for all designated States except US): **FOSTER WHEELER ENERGIA OY** [FI/FI]; Sentnerikuja 2, FIN-00440 Helsinki (FI).

(72) Inventors; and

(75) Inventors/Applicants (for US only): **ERIKSSON, Timo** [FI/FI]; Kirkkokatu 19 E 123, FIN-48100 Kotka (FI).**ISAKSSON, Juhani** [FI/FI]; Muinaishaudankatu 10 C 15, FIN-33710 Tampere (FI). **KUIVALAINEN, Reijo** [FI/FI]; Mäihäpolku 7 D, FIN-48400 Kotka (FI). **LEHTONEN, Pekka** [FI/FI]; Talvikkitie 3 A 7, FIN-48800 Karhula (FI). **PALONEN, Juha** [FI/FI]; Häyriänkatu 2-4 A 4, FIN-78850 Varkaus (FI).(74) Common Representative: **FOSTER WHEELER ENERGIA OY**; Patent Department, Antintie 3, P.O. Box 66, FIN-48601 Karhula (FI).

(81) Designated States (national): AE, AG, AL, AM, AT, AU, AZ, BA, BB, BG, BR, BY, CA, CH, CN, CR, CU, CZ, DE, DK, DM, DZ, EE, ES, FI, GB, GD, GE, GH, GM, HR, HU, ID, IL, IN, IS, JP, KE, KG, KP, KR, KZ, LC, LK, LR, LS, LT, LU, LV, MA, MD, MG, MK, MN, MW, MX, NO, NZ, PL, PT, RO, RU, SD, SE, SG, SI, SK, SL, TJ, TM, TR, TT, TZ, UA, UG, US, UZ, VN, YU, ZA, ZW.

(84) Designated States (regional): ARIPO patent (GH, GM, KE, LS, MW, MZ, SD, SL, SZ, TZ, UG, ZW), Eurasian

[Continued on next page]

(54) Title: METHOD AND APPARATUS FOR TREATING HIGH PRESSURE PARTICULATE MATERIAL

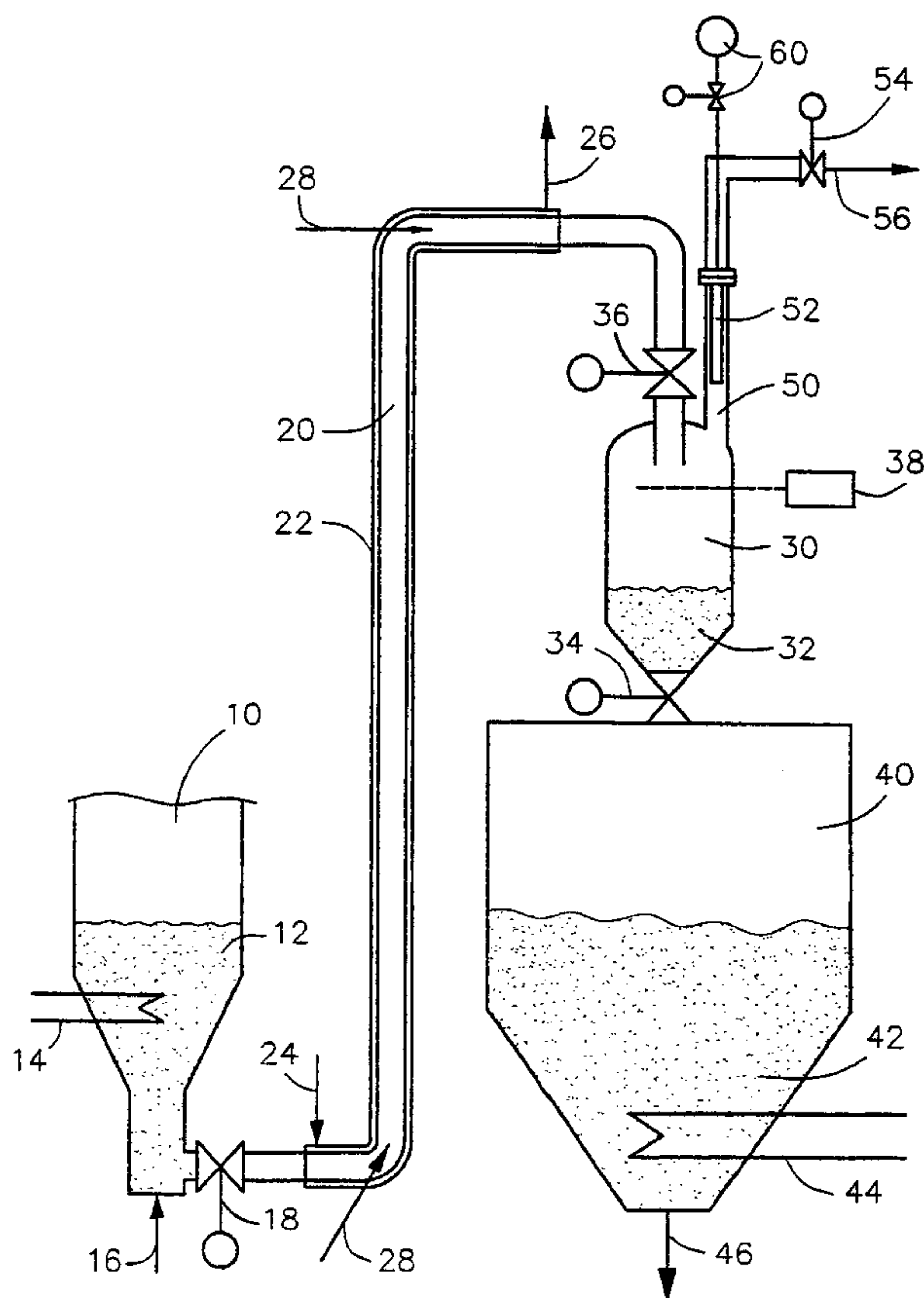

(57) Abstract: A method and an apparatus for conveying particulate material of a reactor pneumatically from a high pressure delivery vessel (10) to a receiving vessel (40) at a lower pressure using gas discharging from the reactor as a carrier gas, by using an apparatus comprising a conveyor line (20) and a collecting vessel (30), which collecting vessel comprises means (50) to discharge carrier gas and means (54) to control the flow rate of the carrier gas, in which the pressure in the collecting vessel is controlled in such a way that the material has almost the same pressure as the delivery vessel when conveyed to the collecting vessel, from which it is transferred to the receiving vessel essentially at the same pressure as the receiving vessel.

WO 01/00313 A1

WO 01/00313

PCT/FI00/00546

1

**METHOD AND APPARATUS FOR TREATING HIGH PRESSURE PARTICULATE MATERIAL**

5

**Field of the Invention**

The present invention relates to methods and an apparatus for treating high pressure particulate material. In particular, the invention relates to a method and apparatus for  
10 pneumatic conveying of particulate material containing reaction products of a high pressure reactor, by using the gas exiting the reactor as a carrier gas, from a supply vessel at a pressure of at least 2 bar to a receiving vessel at a considerably lower pressure, by using an apparatus comprising  
15 a conveyor line and a collecting vessel between the conveyor line and the receiving vessel.

**Background of the Invention**

It is generally known to convey solid powdered or granular material by a pneumatic conveyor system. When transported  
20 pneumatically, solid material is conveyed in a tubular conveyor line entrained with the carrier gas flowing therein. Pneumatic conveyance is possible for diluted suspensions, whereby a relatively large quantity of gas conveys a relatively small volume of solid material, or for denser  
25 suspensions, whereby a relatively small quantity of gas conveys a relatively large volume of solid material.

Pneumatic conveyance is normally performed by feeding superatmospheric carrier gas to a conveyor line or by  
30 providing a low pressure in the receiving vessel in the latter end of the conveyor line. Pneumatic conveyance is especially applicable in situations where the supply vessel is for some other reason at a higher pressure than the receiving vessel. Thus it could be possible to utilize the  
35 gas in the supply vessel for conveying particulate material

and it is not necessary to separately arrange carrier gas supply or pressure difference between the vessels.

5 US patent 4,699,210 discloses a system to convey fly ash from a pressurized fluidized bed boiler separated by its particle separator in such a way that the material to be conveyed is led from the bottom portion of the separator to the ash container through a conduit where its flow direction is sharply changed repeated times. Every change of direction  
10 consumes energy, whereby the pressure of the flue gas conveying the ash is reduced gradually on its way from the particle separator to the ash container.

A drawback in this conveyor system is the clogging of the  
15 conveyor line's sharp bends, especially if the ash temperature decreases close to the dew point. To prevent the clogging of the line the ash is conveyed as a thin suspension, whereby the flow rate of the gas needs to be high enough, at least 10 - 15 m/s. This results, however, in high  
20 consumption of carrier gas and increases thus the energy consumption substantially. In addition, the high flow rate can cause strong erosion especially at the bends of the line where the direction changes.

25 US patent 4,877,423 discloses a two-stage pneumatic system applicable to conveying and cooling high pressure fly ash, at the first stage of which system, where flue gas is used as a carrier gas, the pressure is reduced only slightly, typically only 0 - 3 bar. In the end section of the first stage is  
30 arranged a precipitator to separate flue gas from ash, and a high pressure supply tank for ash. Subsequent to the supply tank the system comprises a lock tank separated by a valve, in which tank the pressure can be reduced to a level required by the further transport and final cooling of the ash.

CA 02376945 2001-12-21

2a

The disclosed arrangement with a separate precipitator and two tanks is, however, quite complicated and expensive. Furthermore, the ash discharge of the separator treating the entire ash quantity and having no longer any carrier gas flow, has a tendency to get clogged up, if the ash is adhesive at least to some extent. This prevents the ash from being efficiently cooled at the first stage.

10 European patent 0 582 049 discloses a system for depressurizing and conveying particulate materials, where the solids flow rate in the pneumatic conveyor line is controlled by changing the cross section of a choke means and/or by changing the pressure in a reservoir upstream the conveyor  
15 line. The material is also depressurized by the mechanical choke means.

US patent 5,707,198 discloses a system for discharging particulate material from a first container to a lower  
20 positioned, lower pressure storage area. The quantity of material discharged to the storage area is controlled by a material feeder. The pressure of the material is reduced in the material columns formed in an upper tube section between the first container and a pressure stabilizer and a lower  
25 tube section between the pressure stabilizer and the feeder.

Japanese patent publication JP 07042910 discloses a system for pneumatic conveying of particulate material, where the material is first conveyed to a high pressure ash storing  
30 device, from where it is transferred to a separate hopper in order to reduce the pressure to the atmospheric pressure, and then the material is finally transferred to a normal pressure hopper.

AMENDED SHEET

Empfangszeit 13. Juli 8:02

Summary of the Invention

It is an object of the present invention to provide a method and apparatus for treating particulate material, in which the above-mentioned prior art problems are minimized.

- 5 It is a special object of the present invention to provide a simple method and apparatus for controlled pneumatic conveyance and cooling of hot high pressure particulate material.
- 10 It is a further object of the invention to provide a method and apparatus for pneumatic conveyance of hot high pressure particulate material, in which no overheating and clogging of the conveyor line occur.
- 15 It is also an object of the invention to provide a method and an apparatus, by which the conveying speed of ash can be controlled and the consumption of carrier gas diminished.

20 In order to solve the above problems a method, the characterizing features of which are disclosed in the characterizing part of the independent method claim, is provided. Thus the method according to the present invention is characterized in that the receiving vessel comprises a discharge conduit for carrier gas and means to control the

flow rate of carrier gas and that the method comprises the steps of:

- (a) controlling the pressure in the collecting vessel by using the means to control the flow rate of carrier gas so that material is conveyed from the supply vessel to the collecting vessel essentially at the same pressure as is prevailing in the supply vessel, and
- (b) conveying material from the collecting vessel to the receiving vessel essentially at the same pressure as is prevailing in the receiving vessel.

In order to solve the above prior art problems an apparatus, the characterizing features of which are disclosed in the characterizing part of the independent apparatus claim, is also provided. Thus the apparatus according to the present invention is characterized in that the receiving vessel comprises a discharge conduit for carrier gas and means to control the discharge velocity of the carrier gas from the collecting vessel, and means to control the pressure of the particulate material collected in the collecting vessel.

The conveyance according to the present invention includes that the flow rate of gas in the conveyor line is preferably relatively low, most preferably less than 5 m/s and particulate material is conveyed as a dense suspension. When the present invention is applied, the frictional forces of the conveyor line are relatively small, whereby the relatively small pressure difference compared to the pressure prevailing in the supply vessel, typically less than 1 bar, between the supply vessel and the collecting vessel, provides a desired flow.

Prior to the conveyance the particulate material may form a thin or a dense layer, e.g. a fluidized bed, in the bottom of

the supply vessel. The conveyor line may be attached to the supply vessel at the bottom or on the side thereof.

Particulate material can be preferably cooled in the conveyor line by arranging the line at least in some part/-s coaxially so that the particulate material flows in the inner tube and the cooling medium, e.g. water or steam, in the outer tube. A mixer can be also provided between the cooled parts securing that the material is cooled uniformly. The cooling may also be performed or intensified by arranging a heat exchange surface in the supply vessel, collecting vessel or in the receiving vessel.

To prevent clod formation in the conveyed material causing clogging of the conveyor line the material should not be cooled close to the dew point temperature of the carrier gas, i.e., typically, flue gas of a reactor. When utilizing the ash conveyance system according to the present invention, the cooling of the material in the conveyor line can be continued to a lower temperature, if air is added to the carrier gas. Preferably this can be performed by fluidizing the material in the bottom of the supply vessel by air, whereby the flue gas content in the carrier gas is diminished, the partial pressure of water steam and acids is reduced and the dew point of the carrier gas is decreased.

In the method according to the present invention the carrier gas flow from the collecting vessel is adjusted so as to create a desired flow rate for the material between the supply vessel and the collecting vessel. As the discharge conduit for carrier gas is attached to the collecting vessel, the conveyance of the material continues efficiently up to the collecting vessel and the risk that the conveyor line gets clogged up is diminished.

In the following some preferred embodiments of the present invention are described as applied to the ash conveyance of a pressurized fluidized bed reactor, but equivalent and other  
5 embodiments according to the present invention can be used also in connection with other types of reactors and other particulate materials.

If carrier gas is allowed to discharge from the collecting  
10 vessel directly to the open air, a substantial amount of particulate material to be conveyed, e.g. ash, may also be discharged. According to a first preferred embodiment of the invention the carrier gas is allowed to discharge from the collecting vessel through one or more porous filter element/-  
15 s. The filter elements can be located inside the collecting vessel or in separate gas discharge pipes outside the collecting vessel. From the filter elements the gas is allowed to discharge to the open air or to another vessel which is substantially at the same pressure as the receiving  
20 vessel, e.g. at atmospheric pressure. The gas flow is controlled by the control elements located downstream of the filter elements, which control elements can comprise e.g. a control valve or a combination of an orifice plate and a shut-off valve or a combination of a control valve and a  
25 shut-off valve.

The ash entrained with the carrier gas to the filter may disturb or even prevent the gas flow. In order to avoid this, the collecting vessel is formed as a settling vessel, whereby  
30 it serves as a preseparator for ash. As a certain amount of ash is in any case entrained with the carrier gas, the filter elements can preferably be cleaned from the material collected on their surface by using high pressure gas pulses.

According to a second preferred embodiment of the invention the carrier gas is allowed to discharge from the collecting vessel through an orifice of proper size directly to the receiving vessel. Thus the ash entrained with the gas is not allowed to reach the environment but is directed to the receiving vessel. The drawback of this embodiment could be the erosion or plugging of the orifice deriving from ash. To eliminate this problem the orifices are preferably made easily changeable.

10

To control the ash flow rate the gas discharge system comprises preferably two or more parallel gas discharge conduits having an orifice of the same size or of different sizes between the collecting vessel and receiving vessel. The carrier gas discharge conduits are provided with valves, by shutting and opening of which the gas discharge and the ash flow in the conveyor line can be controlled.

As the gas is discharged to the receiving vessel, the receiving vessel needs to be provided with a gas discharge opening, e.g. to the open air, and a filter preventing the ash from exiting through the discharge opening.

The ash conveyor system according to the above preferred first and second embodiments of the present invention is preferably used intermittently, whereby ash is collected in the collecting vessel until its surface reaches a certain predetermined level. After this the ash collected in the collecting vessel is discharged to the receiving vessel.

30

As the receiving vessel is typically at atmospheric pressure or at least essentially at a lower pressure than the collecting vessel during the conveyance of ash, the pressure of the material to be discharged has to be reduced close to

the pressure of the receiving vessel before discharging the collecting vessel. To reduce the pressure in the collecting vessel a shut-off valve can be disposed in the ash conveyor line, preferably at its end closest to the collecting vessel making it possible to separate the collecting vessel from the conveyor line.

Preferably the discharge of the collecting vessel is started by closing the valve controlling the gas exhaust from the collecting vessel. Thus the gas pressure in the conveyor line is increased essentially to the same pressure level as the gas in the supply vessel and the ash flow in the conveyor line is stopped. Next, the shut-off valve arranged in the conveyor line is shut and the valve controlling the discharge of the gas in the collecting vessel is reopened, whereby the gas pressure in the collecting vessel is reduced. When the pressure is low enough, the collected ash is removed from the collecting vessel to the receiving vessel.

The collecting vessel can preferably be disposed above the receiving vessel, whereby the ash is allowed to fall directly down to the receiving vessel, after the pressure in the collecting vessel has been allowed to fall to the same level as the pressure in the receiving vessel.

The ash can be conveyed from the collecting vessel to the receiving vessel also by other means, e.g. by using a screw or pneumatically, whereby the pressure in the collecting vessel can remain even slightly higher than the pressure in the receiving vessel, when the pressure is reduced, and the carrier gas can be used for conveying the ash to the receiving vessel.

The essential idea of the present invention is that the valve disposed in the conveyor line is not used for controlling the ash conveying speed, but only for separating the collecting vessel from the conveyor line after the ash flow has been  
5 stopped by the valves controlling the gas discharge.

The valves controlling the gas exhaust can preferably be used not only for stopping the ash conveyance for the discharge of the collecting vessel, but also for controlling the ash  
10 conveying speed. It is especially preferable to change the conveying speed intermittently, e.g. so that the conveyance is performed essentially at constant speed, but is stopped completely at regular intervals. Thus excessive rising or falling of temperature as well as the generation of  
15 agglomerations disturbing the conveyance can be prevented. If ash is collected only to a minor extent, even carrier gas can be saved by using intermittent ash conveyance thus improving the efficiency of the plant.

20 Intermittent stopping of the ash conveyance can be controlled on the basis of certain variables measured in the conveyance system. The ash conveyance can be stopped e.g. when the temperature of the ash entering the collecting vessel or the pressure difference between the supply vessel and collecting  
25 vessel is too high or too low. Too high a temperature indicates that the volume of ash to be conveyed is so large that the cooling has no time to reduce its temperature sufficiently. Too high a pressure difference indicates that the line might be about to get plugged and the gas discharge  
30 from the collecting vessel has to be temporarily shut in order to control the situation.

On the other hand, too low a pressure difference or a temperature of the entering ash can indicate that the ash

conveyance is insignificant, probably for the reason that there is no ash in the supply vessel. In this case the conveyance should be temporarily stopped in order to save carrier gas and energy. Excessive cooling of the ash also  
5 increases the risk of plugging of the conveyor line. The temperature of the ash entering the collecting vessel is preferably less than 300 °C, more preferably 100 - 200 °C. The pressure difference between the supply vessel and the collecting vessel is preferably 0.1 - 1.0 bar or less than  
10 0.3 bar for each 10 m of the conveyor line.

The conveyor systems according to the above-described first and second embodiments of the present invention can be used e.g. for conveying fly ash separated by a flue gas filter  
15 unit of a pressurized fluidized bed reactor used for combustion or gasification of material.

According to a third preferred embodiment of the present invention the collecting vessel has a tubular form and it is  
20 arranged in a vertical position so that ash enters the collecting vessel through its upper part. Typically, the proportion of the height and the diameter of the collecting vessel is at least 5, more preferably at least 10, but it can preferably be even over 30. Thus the first gas discharge pipe  
25 provided with a filter is preferably disposed in the lower part of the vessel and the ash discharge system in the bottom of the vessel. There are possibly a plurality of gas discharge pipes at various levels of the vessel. The filter attached to the discharge pipes can preferably be arranged inside the  
30 tubular collecting vessel in contact with the material to be conveyed.

When using the ash discharge system according to the third preferred embodiment, the ash disposal from the collecting

vessel is preferably controlled by an ash column having an approximately constant height in the tubular collecting vessel. As the carrier gas passes through the ash column, its pressure falls without any separate means so that ash can be removed from the lower part of the collecting vessel, directly to an ash container, e.g. at atmospheric pressure. This kind of a conveyance system is particularly suitable for removing coarse bottom ash, e.g. from the furnace of a fluidized bed reactor used for combustion or gasification of material.

10

The collecting vessel according to the above-described third embodiment can also be dimensioned so that it has a self-adjusting overflow protector. Thus the diameter and the height of the vessel have to be such that the airflow through the ash column slows down essentially before the ash column in the vessel is too high, whereby the ash conveyance to the collecting vessel is reduced or even stopped completely.

In all above-described embodiments the conveyor line comprises parts that can be oriented with any desired position, i.e. vertical, horizontal or oblique. If necessary, the flow of the particulate material in the conveyor line, especially where the line is bent, can be assisted by introducing small quantities of carrier gas, e.g. air, into the line continuously or intermittently.

The invention is characterized in that there are no valves for controlling the conveying speed of the ash in the ash conveyor line. There can be shut-off valves in the line intended to be used when a part of the system needs to be separated from the others, e.g. for maintenance.

#### Brief Description of the Drawings

In the following the invention will be described more closely with reference to the accompanying drawings, in which

Fig. 1 schematically illustrates an ash conveying system according to a first preferred embodiment of the present invention;

5

Fig. 2 schematically illustrates the outlet end of the ash conveying system according to a second preferred embodiment of the present invention;

10 Fig. 3 schematically illustrates the outlet end of the ash conveying system according to a third preferred embodiment of the present invention;

Detailed Description of the Preferred Embodiments

15 Fig. 1 illustrates an ash conveying system according to a first preferred embodiment of the present invention, the supply vessel 10, ash conveyor line 20 and receiving vessel 40 of which can be similar to those even in other preferred embodiments. The various embodiments differ from each other mainly in how the carrier gas discharge from the collecting  
20 vessel 30 and the pressure reduction of the collected material are arranged.

The invention is characterized in that particulate material containing reaction products of a reactor is conveyed  
25 pneumatically from a supply vessel 10 at a pressure of at least 2 bar, typically at 6 - 20 bar, to a receiving vessel 40, e.g. at atmospheric pressure, using the gas exiting the reactor as a carrier gas. When applying the invention the volume of the supply vessel is typically larger than the  
30 volume of the conveyor line and it can be assumed that the pressure of the supply vessel is constant.

The supply vessel 10 can consist e.g. of a bottom part of a filter for fly ash from a high pressure fluidized bed reactor

or it can be a part of the removal system for bottom ash from a fluidized bed reactor. In the former case the ash 12 collected in the supply vessel is powdered, compressible fly ash, whereas in the latter case the ash could be coarse. The  
5 quality of the ash to be conveyed has to be considered when choosing the embodiment and the method, by which the system according to the present invention is applied.

In the supply vessel the ash temperature is typically 400 -  
10 1200 °C and for precooling the ash the vessel can be provided with heat exchange surfaces 14, e.g. heat exchange pipes, in which water or steam circulates.

The ash is conveyed in a tubular conveyor line 20, in which a  
15 heat exchange surface could be arranged, e.g. a sleeve 22 covering the line at least partly and having means 24, 26 for the recirculation of heat exchange medium, e.g. water or steam. By the heat exchange surfaces 22 the ash temperature can be reduced, e.g. to 150 - 300 °C.

20

It is possible to arrange means 16 for the introduction of fluidizing gas, e.g. air, at the bottom of the supply vessel. These can prevent the clogging of the lower part of the collecting vessel deriving from the arching of ash. Further,  
25 fluidizing air can be mixed in the carrier gas used in the conveyance, and reduce its dew point. Thus the clogging of the conveyor line due to moistening as the result of ash cooling can be prevented.

30 In Fig. 1 the conveyor line 20 starts below the supply vessel, turns upwards after the horizontal section and leads again horizontally above the collecting vessel 30. In practice, the conveyor line can consist of parts with any desired position. To avoid the clogging of the line it could

be occasionally or continuously necessary to add small quantities of carrier gas 28, e.g. air, to some points of the line, especially to the bent sections.

5 The ash conveyor line 20 ends in the collecting vessel 30, to which a discharge conduit 50 for carrier gas is attached. The conveyor line 20 is preferably formed of an extension part 32 extending slightly into the collecting vessel and directing the ash towards the bottom of the collecting vessel 30 thus  
10 reducing the probability of the ash being entrained with the gas to the discharge conduit 50. The collecting vessel 30 is also formed so as to reduce the speed of the carrier gas essentially when flowing from the extension part 32 of the conveyor line 20 to the collecting vessel. Thus the  
15 collecting vessel serves as a settling chamber for ash separating a substantial part of the ash conveyed by the carrier gas.

In the embodiment according to Fig. 1 the discharge conduit  
20 50 is provided with a filter 52 and a control valve 54 for controlling the flow rate of the discharged carrier gas 56. The discharge conduit leads preferably to the open air or to a space essentially at atmospheric pressure. If the pressure of the receiving vessel differs from the atmospheric  
25 pressure, it is preferable to draw the discharge conduit 50 to a space essentially at the same pressure as the receiving vessel.

As ash can be entrained with the carrier gas to the filter  
30 52, the filter is provided with means 60 for cleaning the filter by giving intermittent gas pulses to the clean side thereof.

In the embodiment according to Fig. 1 the collecting vessel 30 is arranged immediately above the receiving vessel 40. The collecting vessel 30 is separated from the receiving vessel 40 by a gas tight valve 34. There is also a gas tight valve 36 between the collecting vessel 30 and the conveyor line 20.

The present invention is characterized in that the gas discharge speed is adjusted by a control valve 54 so as to convey ash in the line 20 as a dense suspension the flow rate of the carrier gas being less than 5 m/s. Thus the erosion and consumption of carrier gas caused by the conveyance are relatively insignificant. Valve 34 is shut and valve 36 is open during the conveyance. It is to be noted that valve 36 is not used for controlling the conveying speed of the ash or for stopping thereof.

In the technical solution according to Fig. 1 a valve 18 is also arranged between the supply vessel 10 and the conveyor line 20. The system may include such a valve and possibly even other valves not marked in the figure, as they do not have any significance from the viewpoint of the present invention. Valve 18 could be needed e.g. when maintaining the system, but in normal operation the valve is open.

When the level transmitter 38 attached to the collecting vessel 30 indicates that the collecting vessel is about to get filled, the ash conveyance is stopped. The carrier gas flow is stopped by shutting valve 54. When the ash conveyance is stopped, valve 36 is shut. After this, valve 54 is reopened and the pressure of the collecting vessel is allowed to fall so that it is essentially the same as the pressure of the receiving vessel and the ash can fall down into the receiving vessel by opening the valve 34.

To restart the ash conveyance, valve 34 is shut, valve 36 is opened and the ash flow rate is adjusted by valve 54 to a desired value. To protect valve 36, it could be necessary to raise the pressure of the collecting vessel essentially to the same level as that of the supply vessel 10. This can preferably be performed by using a system 60 producing cleaning pulses for the filter 52 of the discharge conduit 50. Simultaneously, the filter is also cleaned from ash possibly collected on its surface at the preceding filling stage of the collecting vessel. The receiving vessel can be provided with heat exchange surfaces 44 for the final cooling of the ash as well as with an opening for ash discharge 46 in the bottom of the vessel.

The ash conveyance system according to the present invention is preferably used intermittently also between the discharges of the collecting vessel 30 so that the temperature  $T_1$  of the ash entering the collecting vessel 30 at the end of the conveyor line 20 and the pressure difference  $\Delta p$  between the supply vessel and the collecting vessel are monitored. When  $T_1$  or  $\Delta p$  is not within the predetermined limits, the discharge of carrier gas and the ash conveyance are stopped by valve 54. Sometimes it could be sufficient to perform the ash conveyance in a predetermined way intermittently. The ash conveyance can also be stopped when it is detected that the volume of ash in the supply vessel falls below a predetermined level.

Fig. 2 schematically illustrates the outlet end of the ash conveying system according to a second preferred embodiment of the present invention. There the collecting vessel 130, receiving vessel 140, valves 136 and 134 and the parts missing in the figure are similar to those in the embodiment

according to Fig. 1. The operational principle of this embodiment is also similar to that of the embodiment according to Fig. 1.

5 The second preferred embodiment according to Fig. 2 differs from the first preferred embodiment according to Fig. 1 in that the discharge conduit for carrier gas is in communication with the receiving vessel 140. Thus also the ash entrained with the carrier gas is led to the receiving  
10 vessel 140. Naturally, when using the second preferred embodiment according to Fig. 2, the receiving vessel has to be provided with a discharge conduit 162 for gas, e.g. to the open air, and a filter preventing the ash from being entrained out with the gas.

15

In the embodiment according to Fig. 2 the discharge conduit is divided into three parallel conduits 150, 150' and 150'' joining to one conduit 160 before reaching the receiving vessel 140. As the ash entrained with the carrier gas could  
20 deteriorate the operational condition of the control valve, the control valve 54 of Fig. 1 has been replaced by steadier shut-off valves 154, 154', 154'' and critical openings 158, 158', 158'', like or unlike each other, restricting the gas flow. Naturally the number of parallel conduits can also be  
25 different from three.

In the embodiment according to Fig. 2 the ash conveying speed can be controlled by opening a necessary number of the shut-off valves 154, 154', 154''. If ash is conveyed periodically,  
30 the extent of the conveyance can also be regulated by changing the duration of the periods, whereby it is not necessary to have more than one discharge conduit, shut-off valve and critical opening.

Fig. 3 schematically illustrates the outlet end of the ash conveying system according to a third preferred embodiment of the present invention. In this embodiment the collecting vessel 230 at the end of the conveyor line is narrow and high, even though its diameter is larger than that of the conveyor line. The proportion of the height of the collecting vessel to its diameter is preferably at least 5, most preferably at least 10.

10 When conveying ash, an ash column is maintained in the collecting vessel extending preferably at least to the center part of the vessel. In the embodiment according to the figure the ash flow is regulated by a discharge conduit 250 for carrier gas attached to the center part of the collecting  
15 vessel, in which conduit the volume of carrier gas 256 can be regulated by a valve 254. At the end of the discharge conduit closest to the collecting vessel is arranged a filter 252 preventing the ash from entering the discharge conduit 250. When the filter is disposed according to the figure inside  
20 the ash column flowing downwards, the moving ash simultaneously cleans the outer surface of the filter and prevents the filter from being clogged up.

Another advantage gained by arranging the first end of the discharge conduit in the area of the ash column is that the  
25 portion of the ash column above the joining point of the discharge conduit also acts as a restrictor for the carrier gas flow. Thus the ash conveyance is partly self-adjusting as the high ash column slows down the gas flow and reduces or  
30 even stops the ash conveyance, when the collecting vessel is about to get filled.

The discharge conduit 250 can also be arranged in the upper part of the collecting vessel, whereby it functions in the

same way as the discharge conduit according to the first preferred embodiment in Fig. 1. It is also possible to connect the discharge conduit 250 to the lower part of the collecting vessel 230, whereby the flow regulating effect of the ash column is at its highest.

Fig. 3 also shows another discharge conduit 260 for gas provided with a filter 262 and a control valve 264. The purpose of the discharge conduit 260 is to let the carrier gas 266 discharged from the lower part of the collecting vessel enter the open air without any particular obstruction, i.e. during the ash conveyance valve 264 does not essentially limit the gas flow. Thus the lower part of the collecting vessel 230 reaches the atmospheric pressure and the ash 272 can be easily removed from the lower part of the collecting vessel to the receiving vessel, e.g. by using a rotary feeder 270. The discharge apparatus for ash at the bottom of the collecting vessel can also be another, e.g. a conveyor screw or an L-valve. Pressure adjusting in the collecting vessel can also be practiced in many steps, whereby more than the mentioned two discharge conduits for gas are disposed in the collecting vessel.

Fig. 3 also shows a level transmitter 238 provided in the upper part of the collecting vessel, and an apparatus 258 for feeding high pressure cleaning pulses to the filters 252 and 262. The collecting vessel can also be used so that the upper surface of the ash column is continuously maintained on a desired predetermined level by using a rotary feeder 270. Another possibility is to use a rotary feeder intermittently, whereby the ash level remains within certain predetermined limits.

When starting the ash treatment system according to Fig. 3, e.g. sand can be fed to the collecting vessel through a separate conduit not shown in Fig. 3, whereby a sand column restricts the gas flow at the starting stage.

5

The invention has just been described in connection with embodiments that are presently considered as the most preferable, but it must, however, be understood that the invention is not limited to these embodiments only, but it  
10 also covers a number of other arrangements within the scope of invention determined by the patent claims below. E.g. a plurality of ash conveyor lines can lead into the same collecting vessel.

## Claims

1. Method of conveying particulate material containing reaction products of a high pressure reactor, from a supply vessel at a pressure of at least 2 bar to a receiving vessel at a considerably lower pressure, by using an apparatus comprising a conveyor line attached to the supply vessel and a collecting vessel between the conveyor line and the receiving vessel, where said collecting vessel comprises a discharge conduit for carrier gas and means to control the discharge rate of the carrier gas, said method comprising the step of

(a) conveying particulate material from the supply vessel to the collecting vessel pneumatically by using the gas exiting the reactor as a carrier gas, and controlling the discharge rate of the carrier gas to control the pressure in the collecting vessel and the flow rate of the particulate material in the conveyor line,

characterized in that in step (a) material is conveyed from the supply vessel to the collecting vessel essentially at the same pressure as is prevailing in the supply vessel, and that the method comprises the further steps of

(b) reducing pressure of the material collected in the collecting vessel, and

(c) conveying material from the collecting vessel directly to the receiving vessel essentially at the same pressure as is prevailing in the receiving vessel.

2. Method of conveying particulate material according to claim 1, characterized in that step (a) is practiced by conveying particulate material as a dense suspension the flow rate of the carrier gas in the conveyor line being less than 5 m/s and the pressure drop 0.1 - 1.0 bar.

3. Method of conveying particulate material according to claim 1, characterized in that the temperature of the particulate material in the supply vessel is 400 - 1200 °C and the conveyor line is provided with heat exchange surfaces, by which the temperature of the particulate material in step (a) is reduced to less than 300 °C.

4. Method of conveying particulate material according to claim 3, characterized in that the particulate material in the supply vessel is fluidized by air that is mixed in the carrier gas decreasing the dew point thereof.

5. Method of conveying particulate material according to claim 1, characterized in that a filter is arranged in the discharge conduit for carrier gas, the means to control the flow rate of the gas includes a control valve downstream from the filter, and in step (a) the carrier gas is discharged from the collecting vessel to a space at the pressure which is essentially the same as is prevailing in the receiving vessel.

20

6. Method of conveying particulate material according to claim 1, characterized in that the carrier gas is discharged from the collecting vessel to the receiving vessel in step (a).

7. Method of conveying particulate material according to claim 6, characterized in that more than one parallel lines for the discharge of carrier gas are provided between the collecting vessel and the receiving vessel, which lines are provided with a constantly open flow restricting element and a shut-off valve, and the control of the discharge velocity is performed by opening and shutting the shut-off valves.

30

8. Method of conveying particulate material according to claim 7, characterized in that the flow restricting elements are easily changeable.

5 9. Method of conveying particulate material according to claim 5, characterized in that the collecting vessel has an elongated form and it is arranged in a vertical position, and a column of particulate material is maintained in the collecting vessel, and the discharge conduit for carrier gas  
10 is attached to the collecting vessel at the bottom section of the particulate material column.

10. Method of conveying particulate material according to claim 9, characterized in that more than one discharge conduit  
15 for carrier gas are provided and these are attached to the collecting vessel at various levels of the particulate material column.

11. Method of conveying particulate material according to claim 9, characterized in that the pressure in the bottom  
20 section of the particulate material column is approximately the same as is prevailing in the receiving vessel and step (c) is practiced intermittently or continuously from the bottom section of the collecting vessel.

25

12. Method of conveying particulate material according to claim 1, characterized in that a gas tight inlet valve is disposed in the conveyor line before the collecting vessel and a gas tight discharge valve is disposed between the collecting  
30 vessel and the receiving vessel, and steps (a) - (c) are practiced in alteration steps (b) and (c) comprising the sub-steps of:

(b1) stopping the discharge of carrier gas from the collecting vessel by using the means to control the carrier gas flow, whereby the conveyance of particulate material is stopped;

(b2) closing the shut-off valve before the collecting vessel;

5 (b3) allowing the discharge of carrier gas from the collecting vessel until the pressure in the collecting vessel has dropped approximately to the same level as the pressure of the receiving vessel;

10 (c1) opening the discharge valve and conveying the particulate material from the collecting vessel to the receiving vessel; and

(c2) closing the discharge valve, opening the inlet valve and returning to step (a).

15 13. Method of conveying particulate material according to claim 1, characterized in that the collecting vessel is disposed above the receiving vessel and in step (c) the particulate material is allowed to fall down to the receiving vessel.

20

14. Method of conveying particulate material according to claim 1, characterized in that in step (a) the flow rate of the carrier gas is periodically changed by stopping the conveyance for a predetermined time at regular intervals or  
25 when the pressure in the collecting vessel or the temperature of the material entering the collecting vessel is not within predetermined limits.

30 15. Apparatus for pneumatic conveying of particulate material containing reaction products of a high pressure reactor from a supply vessel at a pressure of at least 2 bar to a receiving vessel at a considerably lower pressure, said apparatus comprising a conveyor line attached to the supply vessel and a collecting vessel between the conveyor line and the receiving

vessel, where said collecting vessel comprises a discharge conduit for carrier gas and means to control the discharge velocity of the carrier gas from the collecting vessel, characterized in that the collecting vessel comprises means to control the pressure of the material collected in the collecting vessel, and said apparatus comprises means for conveying the material directly from the collecting vessel to the receiving vessel essentially at the same pressure as is prevailing in the receiving vessel.

10

16. Apparatus for conveying particulate material according to claim 15, characterized in that heat exchange surfaces are disposed in the conveyor line.

15

17. Apparatus for conveying particulate material according to claim 16, characterized in that elements for fluidizing the particulate material are disposed in the supply vessel in such a way that air used for the fluidization is mixed in the carrier gas thus decreasing the dew point of the carrier gas.

20

18. Apparatus for conveying particulate material according to claim 15, characterized in that a filter is disposed in the discharge conduit for carrier gas, the means to control the flow rate of the carrier gas including a control valve is arranged downstream from the filter, and the discharge conduit for carrier gas is in flow communication with the open air.

25

19. Apparatus for conveying particulate material according to claim 15, characterized in that the discharge conduit for carrier gas is in flow communication with the receiving vessel.

30

20. Apparatus for conveying particulate material according to claim 19, characterized in that more than one parallel lines

for the discharge of carrier gas are provided between the collecting vessel and the receiving vessel, which lines are provided with a constantly open flow restricting element and a shut-off valve.

5

21. Apparatus for conveying particulate material according to claim 20, characterized in that the flow restricting elements are easily changeable.

10

22. Apparatus for conveying particulate material according to claim 15, characterized in that the collecting vessel has an elongated form and it is disposed in a vertical position, and the discharge conduit for carrier gas is attached to bottom section of the collecting vessel.

15

23. Apparatus for conveying particulate material according to claim 22, characterized in that more than one discharge conduit for carrier gas are provided and these are attached to the collecting vessel at various levels.

20

24. Apparatus for conveying particulate material according to claim 15, characterized in that a gas tight valve is disposed in the conveyor line before the collecting vessel and between the collecting vessel and the receiving vessel.

25

25. Apparatus for conveying particulate material according to claim 15, characterized in that the collecting vessel is disposed above the receiving vessel and a valve is arranged between the vessels, through which valve the particulate material may fall down to the receiving vessel.

30

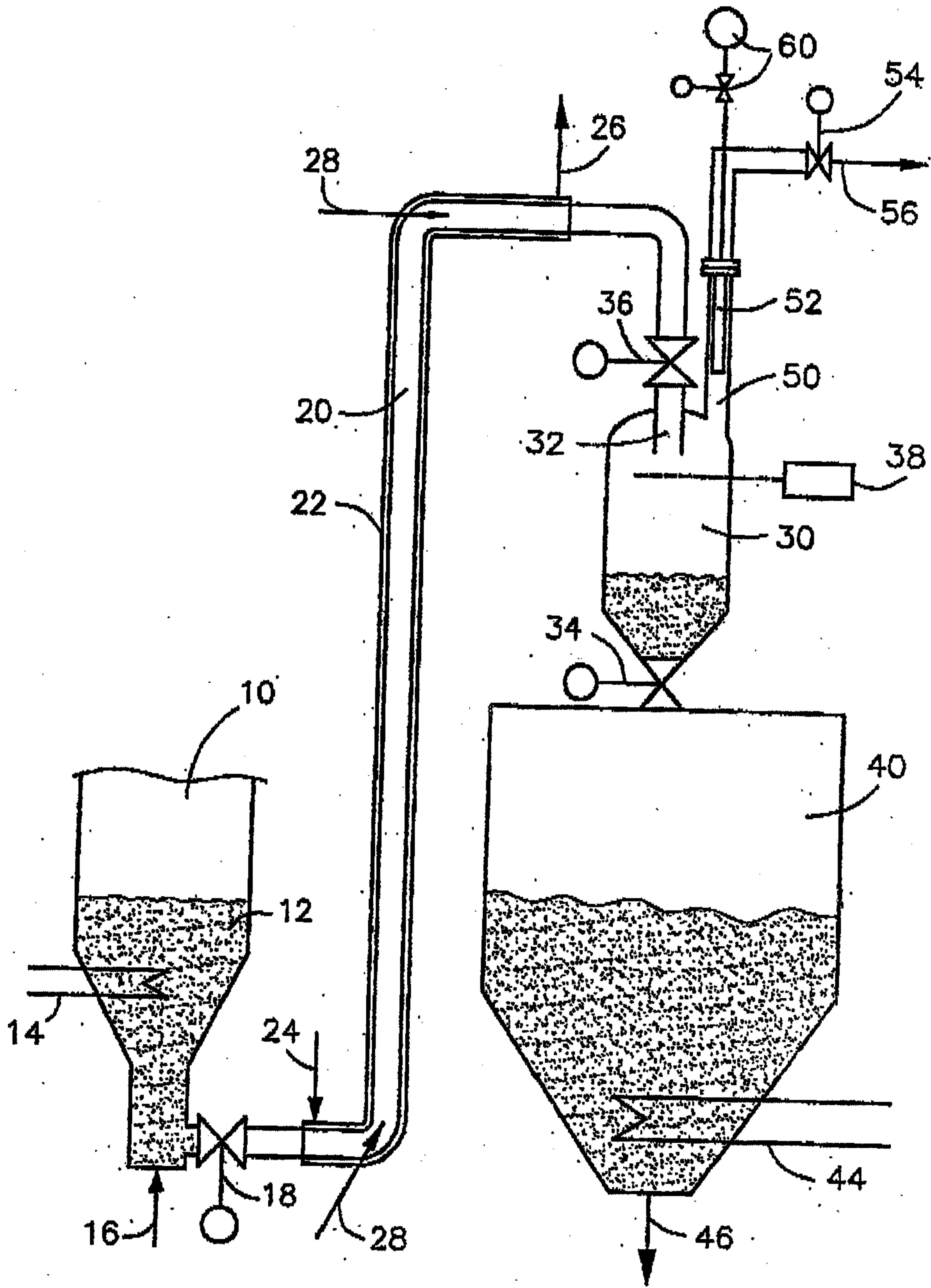

Fig 1.

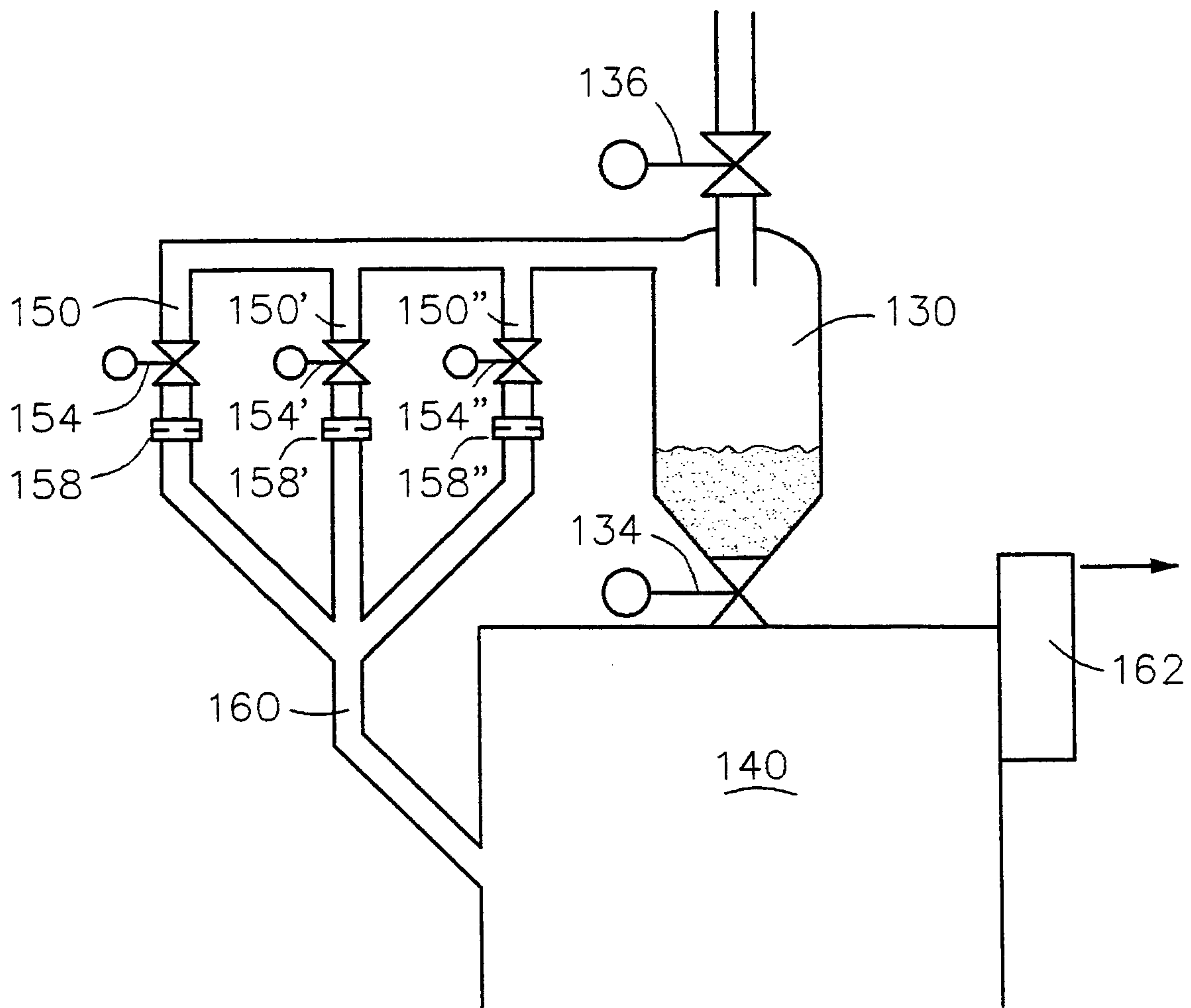

Fig.2

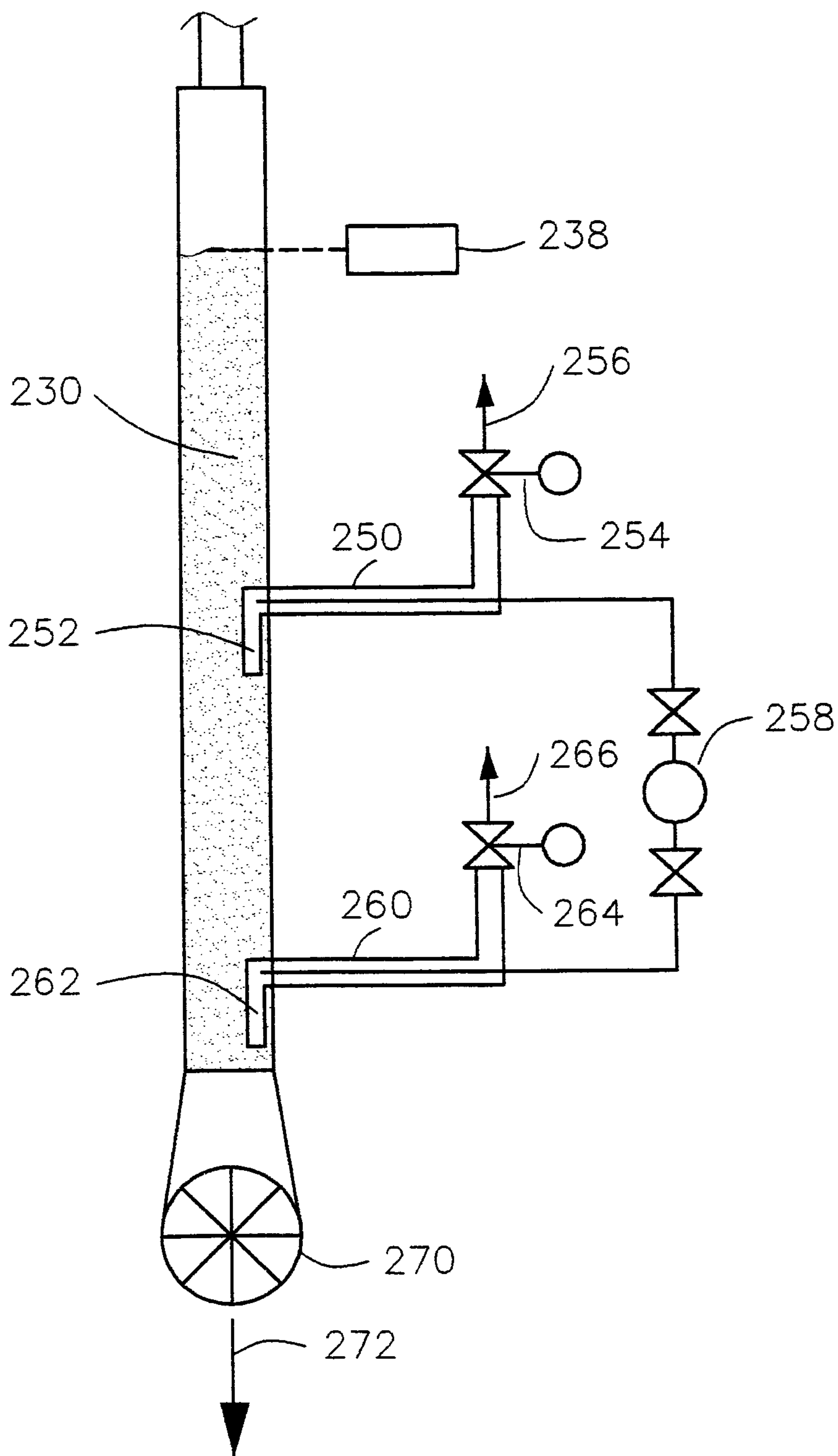

Fig.3

