



- (51) International Patent Classification:
A61F 2/16 (2006.01)
- (21) International Application Number:
PCT/US2013/026820
- (22) International Filing Date:
20 February 2013 (20.02.2013)
- (25) Filing Language: English
- (26) Publication Language: English
- (30) Priority Data:
13/402,398 22 February 2012 (22.02.2012) US
- (71) Applicant: OMEGA OPHTHALMICS LLC [US/US];
P.O.Box 910871, Lexington, KY 40591 (US).
- (72) Inventor: WORTZ, Gary, N.; 325 Walnut Street, Suite
400, Lebanon, KY 40033 (US).
- (74) Agents: GOLDSTEIN, Steven et al.; Frost Brown Todd
LLC, 3300 Great American Tower, 301 East Fourth Street,
Cincinnati, OH 45202 (US).
- (81) Designated States (unless otherwise indicated, for every
kind of national protection available): AE, AG, AL, AM,

AO, AT, AU, AZ, BA, BB, BG, BH, BN, BR, BW, BY, BZ, CA, CH, CL, CN, CO, CR, CU, CZ, DE, DK, DM, DO, DZ, EC, EE, EG, ES, FI, GB, GD, GE, GH, GM, GT, HN, HR, HU, ID, IL, IN, IS, JP, KE, KG, KM, KN, KP, KR, KZ, LA, LC, LK, LR, LS, LT, LU, LY, MA, MD, ME, MG, MK, MN, MW, MX, MY, MZ, NA, NG, NI, NO, NZ, OM, PA, PE, PG, PH, PL, PT, QA, RO, RS, RU, RW, SC, SD, SE, SG, SK, SL, SM, ST, SV, SY, TH, TJ, TM, TN, TR, TT, TZ, UA, UG, US, UZ, VC, VN, ZA, ZM, ZW.

- (84) Designated States (unless otherwise indicated, for every kind of regional protection available): ARIPO (BW, GH, GM, KE, LR, LS, MW, MZ, NA, RW, SD, SL, SZ, TZ, UG, ZM, ZW), Eurasian (AM, AZ, BY, KG, KZ, RU, TJ, TM), European (AL, AT, BE, BG, CH, CY, CZ, DE, DK, EE, ES, FI, FR, GB, GR, HR, HU, IE, IS, IT, LT, LU, LV, MC, MK, MT, NL, NO, PL, PT, RO, RS, SE, SI, SK, SM, TR), OAPI (BF, BJ, CF, CG, CI, CM, GA, GN, GQ, GW, ML, MR, NE, SN, TD, TG).

Published:

— with international search report (Art. 21(3))

- (54) Title: PROSTHETIC CAPSULAR BAG AND METHOD OF INSERTING THE SAME

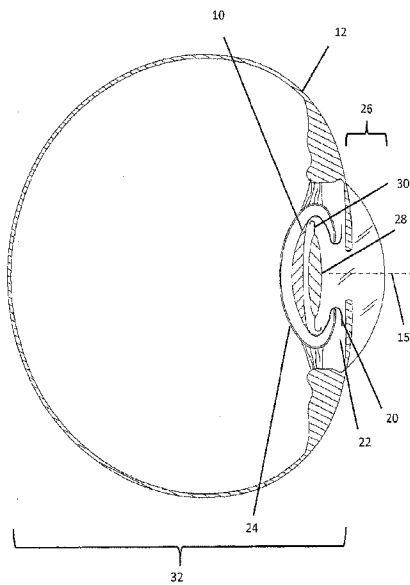

FIG. 1

(57) Abstract: The present invention relates to a prosthetic capsular bag and method for inserting the same. The prosthetic capsular bag helps to maintain the volume of the natural capsular bag, thereby stabilizing the effective lens position of an IOL so that refractive outcomes may be improved with cataract surgery. The prosthetic capsular bag further provides an integrated refractive surface, providing a means for experimentally determining an effective lens position prior to inserting an IOL.



BACKGROUND OF THE INVENTION(a) Field of the Invention

[0001] The present invention relates to a prosthetic capsular bag and method for inserting the same.

(b) Description of the Prior Art

[0002] Cataract surgery is one of the most successfully and most frequently performed surgical procedures in the US. Each year, millions of people achieve a dramatic improvement in their visual function thanks to this procedure. With the increasing proportion of the US population reaching their retirement years, there is expected to be a doubling of the demand for cataract surgery over the next twenty years from 3.3 million to over 6 million annually. This increased demand will require more ophthalmologists to be trained to perform cataract surgery as well as each trained ophthalmologist to perform more cataract surgeries each year.

[0003] In addition to the increase in demand for cataract surgery, there have been many technological advances that have increased patient expectations and requirements for the surgery. The procedure takes a short amount of time to perform, and patients expect quick recovery of visual function. Patients are also asking their ophthalmologist to give them restoration of more youthful vision without glasses through the use of multifocal lenses, presbyopia correcting lenses, toric lenses, and monovision to name a few. The use of these lenses requires perfect technique, perfect preoperative measurements, and a dose of good fortune to ensure patient satisfaction. In fact, as many as 20 - 50% of patients will typically require glasses or follow up refractive surgical enhancements to achieve their

desired refractive endpoint. The reason for this high amount of refractive unpredictability comes from the final resting position of the lens implant within the eye. This is mathematically expressed as the effective lens position ("ELP"), and can be quite variable and unpredictable in the current state of cataract surgery. Recently, hundreds of millions of dollars have been invested into developing highly sophisticated femtosecond laser systems that will be able to more precisely create the cataract incisions with the stated goal of lessening the variability of the ELP and thus aiding in better refractive outcomes. However, as good as the laser is, it does not account for the major problem plaguing the variability of the ELP, which is the volumetric difference between the cataract, natural capsular bag and intraocular lens implant, or IOL.

SUMMARY OF THE INVENTION

[0004] The present invention relates to a prosthetic capsular bag and method for inserting the same. The prosthetic capsular bag addresses the above mentioned problem by helping to maintain the volume of the natural capsular bag, thereby stabilizing the effective lens position of the IOL and improving refractive outcomes with cataract surgery. The prosthetic capsular bag further provides an integrated refractive surface, providing a means for experimentally determining an effective lens position prior to inserting an IOL. Herein, the prosthetic capsular bag of the present invention is referred to as a Perfect Prosthetic Lenticular Capsule or "PPL-C."

[0005] In one embodiment, the present invention is a prosthetic capsular bag for insertion into an eye, the prosthetic capsular bag comprising an anterior surface including an opening, and a posterior surface, wherein at least a portion of the posterior surface is a refractive surface. In this

embodiment, the prosthetic capsular bag is adapted to contain an intraocular lens.

[0006] In a further embodiment, the present invention is a prosthetic capsular bag for insertion into an eye, the prosthetic capsular bag having a generally discoid shape including a posterior surface, an anterior surface including an opening, and a flange extending radially from the opening.

[0007] In another embodiment, the present invention is a prosthetic barrier for separating an anterior segment and poster segment in an eye, the barrier having a generally discoid shape including a posterior surface, an anterior surface including an opening, and an exterior contour flange extending radially from the opening.

[0008] In a further embodiment, the present invention is a method for inserting and positioning an intraocular lens into a patient's eye comprising: (a) inserting a prosthetic capsular bag into the patient's eye, the prosthetic capsular bag including an anterior surface, the anterior surface having an opening, and a posterior surface, wherein at least a portion of the posterior surface is a refractive surface; (b) determining the position of the refractive surface; (c) selecting an intraocular lens based on the determined position of the refractive surface; and (d) inserting the intraocular lens into the prosthetic capsular bag.

BRIEF DESCRIPTION OF THE DRAWINGS

[0009] A better understanding of the present invention will be had upon reference to the following description in conjunction with the accompanying drawings, wherein:

[0010] Fig. 1 depicts a cross-sectional side view of an eye including a first embodiment of a PPL-C containing an IOL.

[0011] Fig. 2 depicts a side elevation view of the first embodiment of the PPL-C;

[0012] Fig. 3 depicts an anterior plan view of the first embodiment of the PPL-C;

[0013] Fig. 4 is a flowchart of a method for inserting and positioning an intraocular lens into a patient's eye;

[0014] Fig. 5 depicts a cross-sectional side view of an eye including a second embodiment of a PPL-C containing an IOL.

[0015] Fig. 6 depicts a side elevation view of the second embodiment of the PPL-C; and

[0016] Fig. 7 depicts an anterior plan view of the second embodiment of the PPL-C.

DETAILED DESCRIPTION OF THE PREFERRED EMBODIMENT

[0017] With reference to Figures 1-3, the PPL-C 10 of the instant invention is shown approximating the size and shape and volume of a natural human lens. Its dimensions would be variable, so that physicians may order an implant that most closely matches the lens of the eye 12 being operated on. The human lens varies in thickness from approximately 3.5mm to 5.5mm. A natural lens tends to be thicker in more hyperopic eyes and thinner in more myopic eyes. Also, the lens thickens over time and increased age is associated with a thicker lens on average. The diameter of the human lens is approximately 9mm. Therefore, in one embodiment, the PPL-C 10 would be a substantially discoid shape of approximately 4.5mm in thickness by 9mm in diameter. For purposes of clarity, the thickness of the PPL-C 10 is the distance between the anterior surface 14 and posterior surface 16 of the PPL-C 10 along the visual axis 15. The anterior surface 14 contains a circular opening 18 approximately 6mm in diameter, with an exterior contour, such as, for example, a 1mm flange 20, surrounding and extending

radially from the opening 18. The flange 20 would further assist in stabilization and centration of the PPL-C 10 by extending into and fitting within the ciliary sulcus 22. This size of PPL-C 10 would function to fit precisely within the capsulorhexis created by a femtosecond laser.

[0018] At least a portion of the inner face 17 of the posterior surface 16 of the PPL-C 10 would be made of a refractive surface so that a pseudophakic refraction could be performed intraoperatively with a known lens already inside the eye, e.g. the posterior refractive surface 19. In a preferred embodiment, as shown in Figs. 1-3, substantially the entire inner face 17 would be made of a low power refractive surface (for example +1D). While the posterior refractive surface 19 is generally discussed in terms of a +1D surface, it may be made of any and all lens powers and designs that are currently known in the art of intraocular lenses. This includes, but is not limited to: spherical, aspheric, wavefront, convex, concave, multifocal (diffractive, refractive, zonal), toric, accommodative, UV filtering, and diffractive chromatic aberration reducing lenses, and optical powers ranging from +30 to -30 diopters.

[0019] The PPL-C 10 is adapted to be implanted within the eye and is preferably made of a biologically-compatible material that would be inert inside the eye. It is preferably deformable so as to be folded and inserted via an injection system through a corneal incision ranging between about 0.1mm and 10mm, preferably between about 1.5mm and 3mm. The size of the corneal incision varies based on several factors, including the volume of the PPL-C 10, its plasticity, and the volume of the injection cartridge through which the PPL-C 10 will be delivered. The capsulorhexis must be about equal to or less than the dilated diameter of the patient's iris as the opacity of the iris forms

a natural barrier for the capsulorhexis created by a femtosecond laser. A capsulorhexis created manually is typically of the same size, as direct visualization of the rhexis boundary is advisable throughout the creation process. The capsulorhexis ranges between about 3mm and 8mm, preferably between about 4mm and 7mm. During implantation, the folded PPL-C 10 passes through the corneal incision, through the capsulorhexis, and into the patient's natural capsular bag 24. The PPL-C 10 preferably also possesses sufficient elasticity to resume its pre-folded shape once positioned inside the eye. Current intraocular lenses are made of various materials including silicone, collamer, and acrylic that have these capabilities. In preferred embodiments, the material used for the PPL-C 10 is a biologically-compatible, optically clear material similar or identical to those used in foldable intraocular lenses.

[0020] The PPL-C 10 would preferably be inserted into the patient's eye 12 through the use of an injection system. The injection system would allow the PPL-C 10 to be automatically folded into a smaller shape as it was advanced so as to allow it to fit through an incision much smaller than the diameter of the unfolded PPL-C 10. The inventor believes that injection systems already developed through which IOLs are injected into the eye, which comprise a cylindrical cartridge and an advancement rod on a screw type advancement system or plunger advancement system, would be suitable for use with the PPL-C 10.

[0021] The PPL-C 10 is preferably inserted into a patient's eye 12 with the use of a laser. A femtosecond laser would be used to create the capsulorhexis, likely after the same device was used to make the other incisions including the main wound, the paracentesis and any corneal or limbal relaxing incisions as necessary. The cataract, i.e., the patient's natural lens, would then be removed using techniques known in the art. The

residual cortex would be removed using technique known in the art, such as via inspiration/aspiration. An aphakic refraction would be completed using an intraocular refracting device such as, for example, the Wavetec ORA system. An IOL calculation would be performed using an algorithm such as, for example, the Mackool algorithm. Then, the patient's natural capsular bag 24 and anterior segment 26 would be filled with viscoelastic material, and the PPL-C 10 would be loaded into the injection device. It would be folded into a small tubular shape and injected into the natural capsular bag 24. The viscoelastic material would be removed from behind the PPL-C, and from the anterior segment 26. A psuedophakic refraction would be done with a system similar to a standard auto-refractor, or the intraoperative Wavetec ORA system. This calculation would need to be done using approved protocols.

[0022] An example refraction using an approved protocol, and accompanying background information, is discussed herein. Current state of the art requires multiple independent variables to be measured so that the dependent variable of effective lens position can be estimated. These independent variables in the Holladay 2 formula (one of the most popular modern formulas) are in decreasing order of importance include: axial length, average keratometric power, horizontal white to white, refraction, anterior segment depth, lens thickness, and age. These variables are then used to estimate the ELP. However, this is simply an estimation or prediction. If this prediction is incorrect, the post-operative refractive outcome will be compromised. Therefore, emphasis should be placed on the ability to determine the ELP rather than estimating it. The PPL-C 10 will help determine the ELP in two different ways, as described in the procedure below.

[0023] Figure 4 is a flowchart depicting a method for inserting and positioning an intraocular lens into a patient's eye. First, the lens thickness of a patient's natural lens is determined pre-operatively using known techniques. Next, a PPL-C 10 of similar thickness will be chosen for implantation. The goal will be to select a PPL-C 10 sized such that the inner face 17 of the PPL-C 10 at the same location as the posterior surface of the patient's natural lens. When an IOL 28 is inserted within the PPL-C adjacent to the inner face 17 and centered within the PPL-C 10, that IOL 28 will be positioned in substantially the identical location previously occupied by the patient's natural lens.

[0024] A femtosecond laser is used to create the main wound, the paracentesis and any corneal or limbal relaxing incisions as necessary, and the capsulorhexis. The patient's natural lens is then removed using techniques known in the art. The residual cortex is removed using techniques known in the art, such as via inspiration/aspiration. Then, the patient's natural capsular bag 24 and anterior segment 26 are filled with viscoelastic material, and the PPL-C 10 inserted into the natural capsular bag 24. The viscoelastic material is then removed from behind the PPL-C, and from the anterior segment 26 in preparation for performing a pseudophakic refraction.

[0025] By being able to identify and control the position of the IOL 28, choosing an IOL 28 is no longer dependent upon the 7 variables for ELP. Rather, via theoretical vergence formulas, the exact IOL 28 needed to provide a desired refractive outcome can be specifically calculated with keratometric power, effective lens position and axial length. The current weakness of the formulas in place is due to the inability to accurately predict ELP. To confirm the pre-operative theoretical calculation is correct, a refraction is performed in the

operating room once the PPL-C 10 is implanted in the patient's eye via a Wavetec ORA system, retinoscopy or by other known methods. The refraction will technically be a pseudophakic refraction as the posterior refractive surface 19 of the PPL-C 10 will have a refractive power, such as, for example, +1 diopter.

[0026] A method of determining the correct intraocular power for a piggyback lens is calculated by first determining the power of the IOL 28 to be implanted using the following equation:

$$IOL\ e = \frac{\frac{1336}{\frac{1000}{PreRx} - V} + K_o}{\frac{1336}{1000} - ELP_o} - \frac{\frac{1336}{\frac{1000}{DPostRx} - V} + K_o}{\frac{1336}{1000} - ELP_o}$$

ELP o = effective lens position.

K o = net corneal power.

IOL e = IOL power.

V = vertex distance.

PreRx = pre-op refraction. (Also can represent the intra-operative refraction after PPL-C has been placed)

DPostRx = desired post-op refraction.

The Effective Lens Position (ELPo) is the distance from the secondary principal plane of the cornea to the principal plane of the thin-IOL equivalent. The keratometric power of the cornea (Kk) is converted to the net optical power of the cornea (Ko) as follows: Ko = Kk * 0.98765431. For example, if the Kk is 44.50 D, Ko = 44.50 D * 0.98765431 = 43.95 D. The net optical power of the cornea (Ko) would then be 43.95 D.

[0027] By comparing pre-operative theoretical IOL calculations with the aphakic refraction, the PPL-C refraction, and the post-IOL implantation refraction, surgeons can greatly improve the accuracy of their post-operative refractive outcomes.

[0028] Once the appropriate IOL 28 is selected, the PPL-C 10 and anterior segment 26 are refilled with viscoelastic material and, based on the residual refractive error, the appropriate IOL 28 is selected and inserted into the PPL-C 10. The viscoelastic material is then removed from the eye, and the wounds closed through standard methods of hydration or suturing. A final confirmatory refraction would be completed, taking great effort to ensure normal intraocular pressure, as this can affect the position of the PPL-C 10 and IOL 28 inside the eye. If there were found to be a significant error at this point, the surgeon would still have the luxury of removing the implanted IOL and replacing it with one of a more desirable refractive power, without risking damage to the fragile natural capsular bag 24, due to the protective nature of having the IOL 28 contained within the PPL-C 10.

[0029] The PPL-C 10 provides an enhanced ability to achieve desired refractive targets, with a side benefit of increased safety. This implant will provide these advantages in several ways.

[0030] First, the PPL-C 10 provides centration of the IOL 28 along the visual axis 15. A femtosecond cataract laser system has the ability to center the capsulorhexis around the visual axis 15 of the patient rather than the optical center of the cataract. The capsulorhexis is ultimately what will center the PPL-C 10 as this is the opening through which the PPL-C 10 will be inserted. The capsulorhexis is essentially juxtaposed at the center of the PPL-C 10, centering the PPL-C 10 and being stabilized via the flange 20 extending into and fitting within the ciliary sulcus 22. The flange 20 mechanically retains the PPL-C 10 centered on the patient's visual axis 15 and prevents future movement or migration of the PPL-C 10.

[0031] Centration of the IOL 28 on the visual axis 15 is extremely important to the visual function of the IOL 28 and the benefit the patient receives. Aspheric lenses have made decentration more tolerable, however centration is absolutely vital to the best visual performance of multifocal intraocular lenses. Decentration of less than 1 mm can cause significant morbidity, so much so that surgical intervention including laser pupiloplasty, IOL repositioning and IOL exchange are often needed. The PPL-C 10 is centered along the visual axis 15 via the capsulorhexis. An IOL 28 commonly includes haptics 30 which can engage opposed interior surfaces within the PPL-C 10 to maintain the centered position of the IOL 28. The outer diameter of the IOL 28, when unfolded and including the haptics 30, is substantially equal to the inner diameter of the PPL-C 10. Therefore, the IOL 28 will be in physical contact with the peripheral internal surface of the PPL-C 10, which maintains the centered position of the IOL 28 within the PPL-C 10 and also within the visual axis 15.

[0032] Second, the PPL-C 10 provides a prosthetic barrier between the anterior segment 26 and posterior segment 32 of the eye in the case of inadvertent rupture of the posterior surface of the natural capsular bag 24, or after planned YAG laser posterior capsulotomy. Despite the overall success of cataract surgery, there is still about a 2% surgical complication rate utilizing modern techniques, although this varies among individual surgeons. Residents in ophthalmology training programs have historically had complication rates around 4-7%. Most complications from cataract surgery are caused by inadvertent rupture of the natural capsular bag 24 which houses the cataract. The natural capsular bag 24 also provides an important anatomical barrier within the eye. It divides the anterior segment 26 from the posterior segment 32. The posterior

segment 32 contains the vitreous body, retina, optic nerve and the central retinal artery and vein. A violation of the integrity of the barrier provided by the natural capsular bag 24 allows fluid communication between the anterior and posterior segments 26, 32, and potentially the ocular surface. Vitreous may then flow out of the posterior segment 32 according to pressure gradients, flowing from high pressure toward low pressure. This typically causes vitreous to flow directly to the surgical incision site. Vitreous can prevent wound healing if it shifts to the surgical incision site, and more significantly can provide a conduit for microbial infections to proceed directly to the posterior segment 32. In addition to the problems caused by vitreous, a break or tear in the natural capsular bag 24 can prevent the stable implantation of an IOL within the posterior segment 32. Alternatively, surgeons can place an IOL 28 in the ciliary sulcus 22 or the anterior chamber, although each of these has their own potential complications associated with them. Therefore it is of utmost importance to keep the natural capsular bag 24 intact as there are currently no methods to consistently reestablish the integrity of the natural capsular bag 24 once it has been compromised. Should the natural capsular bag 24 be compromised, the PPL-C 10 may serve as a prosthetic barrier between the anterior segment 26 and posterior segment 32.

[0033] About 30% of all implanted intraocular lenses will develop visually significant posterior capsular opacification. If this develops, a YAG laser is used to create an opening in the posterior surface of the natural capsular bag 24 to remove this opaque membrane. However, once the hole in the natural capsular bag 24 is created, the barrier between the vitreous and the anterior segment 26 has been lost. Thus, if the lens needs to be removed after a YAG laser posterior capsulotomy has been

performed, it makes the chances for serious complications rise dramatically. However, if a PPL-C 10 is placed in the natural capsular bag 24 and a YAG laser posterior capsulotomy has been performed, there is still an adequate barrier for the vitreous in place. In addition, the haptics 30 which hold the IOL 28 in place inside the PPL-C 10 are not prone to scar formation, thus making future lens removal much easier and decreasing the risk for complications during IOL exchange.

[0034] Third, the PPL-C 10 limits the chronic capsular opacification that takes place in the natural capsular bag 24 and can cause refractive shifts due to ELP change, anterior capsular phimosis, and visually significant posterior capsular opacification. After cataract surgery has been performed, the natural capsular bag 24 undergoes chronic changes. These changes are largely due to the presence of lens epithelial cells that remain on the natural capsular bag 24 after surgery. These epithelial cells continue to grow and can cause problems. For example, the anterior surface of the natural capsular bag 24 can fibrose and contract over time causing a progressively smaller aperture overtop of the lens. If the entire natural capsular bag 24 becomes fibrotic, and phimosis persists, there can be zonular dehiscence and changes to the effective lens position over time. In addition, about 30% of the time, the posterior surface of the natural capsular bag 24 becomes significantly opacified requiring a YAG laser posterior capsulotomy. The effect of limiting epithelial cell migration and propagation would largely be mediated by the type of material used in forming the PPL-C 10, however hydrophobic acrylic materials tend to be most efficacious of all known and used IOL materials.

[0035] Fourth, the PPL-C 10 helps maintain the effective lens position of an IOL 28 implanted into the eye. Precisely matching the preoperative dimensions of the cataract with the

PPL-C 10 enhances a physician's ability to predict the ELP of the lens implant. Currently, the ELP of an IOL 28 is estimated based on a number of factors, including the depth of the anterior segment 26, lens thickness, and white to white diameter, among others. However, these measurements are simply used to predict the ELP. The accuracy of the prediction is actually quite low, resulting in only 50% of patients being within a tolerable level of their refractive goal post-cataract surgery. While other dimensions of the eye required for IOL calculation can be measured quite precisely and accurately, the ELP has remained the elusive last great variable to conquer in the quest for highly accurate and predictable IOL calculations for cataract surgery.

[0036] The reason for the great variability in the ELP is due to the volumetric difference between the cataract and the IOL. The average thickness of the human cataract at age 65 is approximately 4.5mm, however this varies from patient to patient. In contrast, an IOL 28 is typically less than 1mm thick. This volumetric difference allows for pressure differentials between the posterior segment 32 and the anterior segment 26, as well as contraction of the natural capsular bag 24 to shift the final resting position of the IOL 28. The lens thickness will be measured preoperatively and a PPL-C 10 with a corresponding volume and thickness will be implanted. By implanting a PPL-C 10, the volume of the natural capsular bag 24 is effectively held constant. It resists forces that would otherwise shift it and its contents anteriorly or posteriorly. This stability of lens capsule volume will make IOL calculations much more accurate.

[0037] Fifth, the PPL-C 10 allows for an intraoperative pseudophakic refraction while still allowing another IOL to be implanted without explanting the original lens. Recently, there

have been advances in IOL calculation methodologies that use intraoperative refraction devices, such as the Wavetec ORA and Orange systems, to provide better refractive outcomes. These devices can perform aphakic refractions, pseudophakic refractions, and assist with the alignment of toric IOLs and assist with Limbal Relaxing Incisions. Aphakic refractions do not have the benefit of any lens inside the eye, so ELP is still a variable that this data cannot account for. Pseudophakic refractions can be helpful, but it provides the information only after the IOL has been implanted. If the data shows a different lens would be more beneficial, it would require the physician to explants the lens and implant a different one. Explanting a lens takes time, effort and skill, and can cause damage to the cornea or other structures within the eye. Using a PPL-C 10 with a low power lens incorporated into its posterior surface, e.g., the posterior refractive surface 19, allows a physician to perform a pseudophakic refraction with this refractive surface, and still provides the physician the ability to implant a second lens, e.g., the IOL 28, within the PPL-C 10 that will make up the refractive difference as measured by the intraoperative refraction device, such as the Wavetec ORA.

[0038] Sixth, the PPL-C 10 may serve as a means for pharmaceutical delivery. Pharmaceuticals, drugs, medications, such as, for example, slow release medicine pellets, or other substances intended for introduction into the eye may be placed within PPL-C 10 outside of the visual axis 15 in a location that is not subject to sequestration by membrane formation. There is a tremendous amount of research and demand for a slow release implant that would essentially eliminate the need for post cataract surgery eye drops. The PPL-C 10 would be a suitable receptacle for such an implant as the periphery of the interior of the PPL-C provides a location outside of the visual axis 15,

in constant contact with the aqueous humor, without risk of becoming encapsulated by scarring, and prevents the implant from damaging natural intraocular structures. Due to the prosthetic material of the PPL-C 10, there would be no risk of membrane formation or encapsulation. Dissolved or suspended pharmaceuticals would not affect the patient's vision and could be introduced directly into the PPL-C 10 during the implantation surgery. Larger pharmaceuticals, such as slow release medicine pellets, may be shaped to mechanically maintain their position with respect to the PPL-C 10. For example, a slow release medicine pellet may be constructed with a generally toroidal shape sized to fit within the PPL-C, while remaining in the peripheral space and not obstructing the visual axis 15.

[0039] Seventh, the PPL-C 10 provides physicians with the ability to perform a lens exchange in the future that will have much less risk of damage to the natural capsular bag 24 and zonular apparatus. As stated above, if a PPL-C 10 is placed in the natural capsular bag 24 and a YAG laser posterior capsulotomy has been performed, there is still an adequate barrier for the vitreous in place. In addition, the haptics 30 which hold the IOL 28 in place inside the PPL-C 10 are not prone to scar formation, thus making future lens removal much easier.

[0040] Figures 5-7 depict a second embodiment of the present invention. In this embodiment, the PPL-C 110 is a substantially discoid shape of approximately 4.5mm in thickness by 9mm in diameter. The thickness of the PPL-C 110 is the distance between the anterior surface 114 and posterior surface 116 of the PPL-C 110 along the visual axis 15. The anterior surface 114 contains a circular opening 118 approximately 6mm in diameter. At least a portion of the inner face 117 of the posterior surface 116 of the PPL-C 110 is made of a refractive surface, e.g. the posterior refractive surface 119. This second

embodiment of differs from the first embodiment in that the PPL-C 110 lacks a flange and would therefore not be mechanically fixated or centered on the capsulorhexis. Rather, the volume of the PPL-C 110 relative to the opening of the capsulorhexis would keep the device in place much in the same way current single piece IOLs are folded and placed within the natural capsular bag.

[0041] This second embodiment PPL-C 110 sacrifices a measure of stability as compared to the first embodiment PPL-C 10. However, without a flange, this second embodiment is usable for non-femtosecond laser cataract removal, i.e. traditional manual phacoemulsification, and may be particularly useful for surgeons who lack access to a femtosecond laser.

[0042] In a third embodiment, the lenticular surface on the posterior aspect of the device would have a plano powered lens. Some extreme myopes would not benefit from a +1D refractive surface as they may be in need of a negative IOL power. For patients with these conditions, a PPL-C may be used with a plano or zero power posterior lenticular surface.

[0043] In a fourth embodiment, the PPL-C has a -1D posterior refractive lenticular surface as some extreme axial myopes (about 30mm and beyond) may require this type of lens.

[0044] In a fifth embodiment, the posterior refractive surface 19 is a multifocal lenticular surface rather than a standard monofocal +1D surface, which would aid in presbyopia correction. This multifocal lenticular surface includes, but is not limited to, refractive, diffractive, and zonal multifocal refractive technology. Typically, a multifocal lens would be designed to provide multiple focal points that would range from plano, e.g., 0 diopters, to +3D at the spectacle plane.

[0045] In a sixth embodiment, the posterior refractive surface 19 includes a spherical and cylindric (astigmatic)

lenticular surface so as to aid in the correction of pre-existing and surgically induced corneal astigmatism. As most surgeons induce between -0.25D and -0.50D of astigmatism with their corneal incisions required for cataract surgery, it would be beneficial even for most patients with spherical corneas to have this neutralized. The dioptric power of the toric correction could increase up to 6 diopters for patients with even higher amounts of astigmatism.

[0046] The foregoing detailed description is given primarily for clearness of understanding and no unnecessary limitations are to be understood therefrom for modifications can be made by those skilled in the art upon reading this disclosure and may be made without departing from the spirit of the invention.

What is Claimed is:

1. A prosthetic capsular bag for insertion into an eye, said prosthetic capsular bag comprising an anterior surface including an opening, and a posterior surface, wherein at least a portion of said posterior surface is a refractive surface.
2. The prosthetic capsular bag of claim 1, wherein said prosthetic capsular bag is adapted to contain an intraocular lens.
3. The prosthetic capsular bag of claim 1 or 2, wherein said prosthetic capsular bag is a biologically compatible, deformable prosthetic capsular bag, and preferably is substantially discoid in shape.
4. The prosthetic capsular bag of any of claims 1-3, further comprising an exterior contour, preferably a flange which extends into a ciliary sulcus, adapted to mechanically maintain said prosthetic capsular bag at a specific position within said eye.
5. The prosthetic capsular bag of any of claims 1-4, wherein said refractive surface includes at least one of the following optical and design qualities: concave, convex, spherical, aspheric, wavefront, multifocal diffractive, multifocal refractive, multifocal zonal, accommodative, UV filtering, diffractive chromatic aberration reducing, and astigmatism correcting toric form.
6. The prosthetic capsular bag of any of claims 1-5, wherein said refractive surface has an optical power between about +30 diopter and -30 diopter, and preferably has a negative optical power.
7. The prosthetic capsular bag of claim 5, wherein said refractive surface has an optical power of about zero diopter.
8. The prosthetic capsular bag of claim 5, wherein said refractive surface has an optical power of about +1 diopter.
9. A prosthetic capsular bag for insertion into an eye, said prosthetic capsular bag having a generally discoid shape including a posterior surface, an anterior surface including an opening, and a flange extending radially from said opening.

10. A prosthetic barrier for separating an anterior segment and posterior segment in an eye, said barrier having a generally discoid shape including a posterior surface, an anterior surface including an opening, and a flange extending radially from said opening.

11. A method for inserting and positioning an intraocular lens comprising:

a) inserting a prosthetic capsular bag into a patient's eye, preferably within a natural capsular bag within said eye, said prosthetic capsular bag including an anterior surface, said anterior surface having an opening, and a posterior surface, wherein at least a portion of said posterior surface is a refractive surface;

b) determining said refractive surface's position within said eye;

c) selecting an intraocular lens based on said position of said refractive surface; and

d) inserting said intraocular lens into said prosthetic capsular bag,

wherein said prosthetic capsular bag optionally includes a pharmaceutical.

12. The method of claim 11, wherein step a) is preceded by removing a natural lens from a location within said natural capsular bag, said natural lens including opposing anterior and posterior surfaces, and wherein said prosthetic capsular bag is sized such that, when inserted in said natural capsular bag, said refractive surface is at a position substantially identical to said location previously held by said posterior surface of said natural lens.

13. The method of claim 11 or 12, wherein step a) is preceded by forming a capsulorhexis in said eye, and wherein said prosthetic capsular bag is inserted into said eye through said capsulorhexis.

14. The method of any of claims 11-13, wherein said prosthetic capsular bag includes an exterior contour adapted to mechanically maintain said prosthetic capsular bag at a specific position within said eye.

1/7

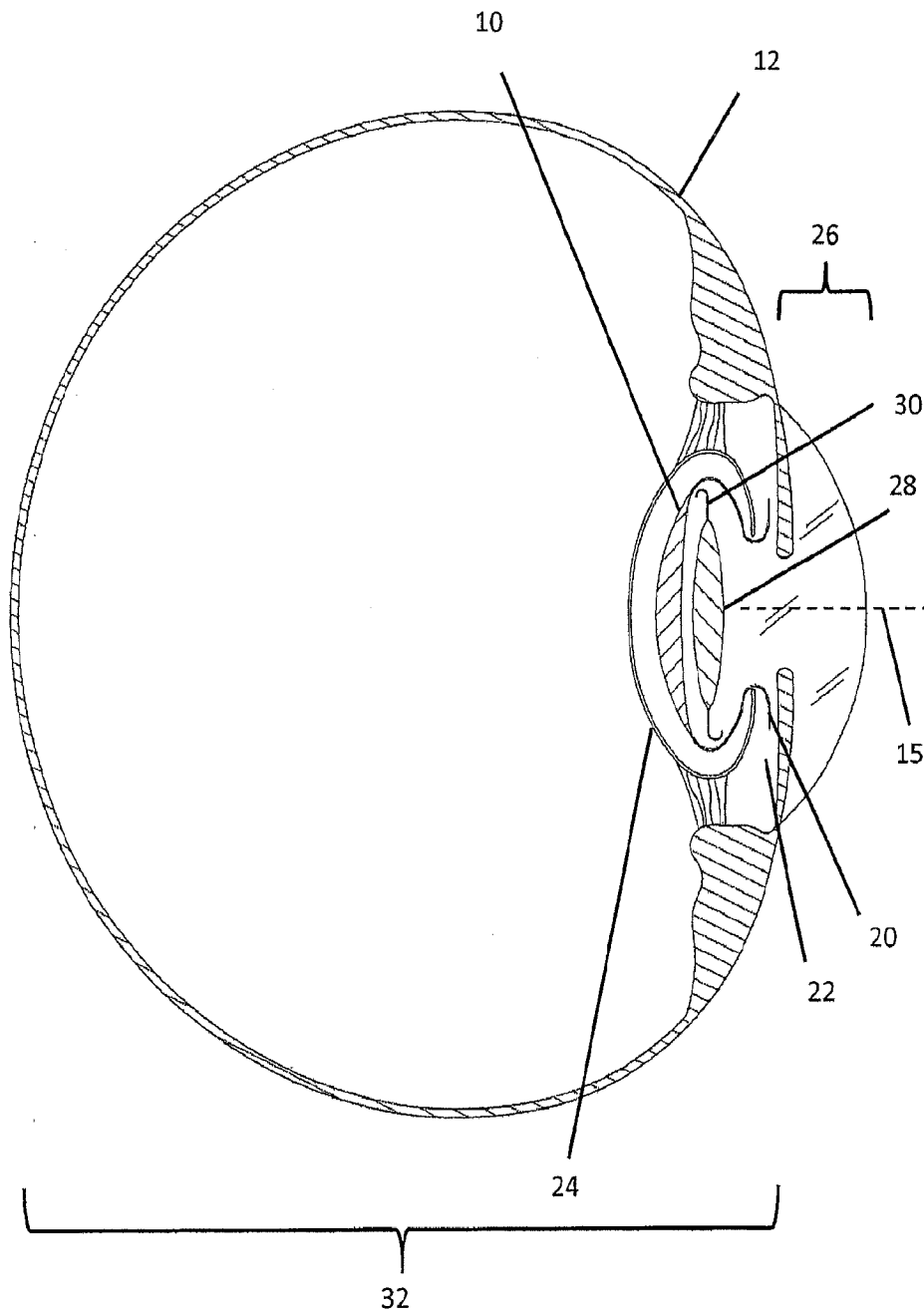

FIG. 1

2/7

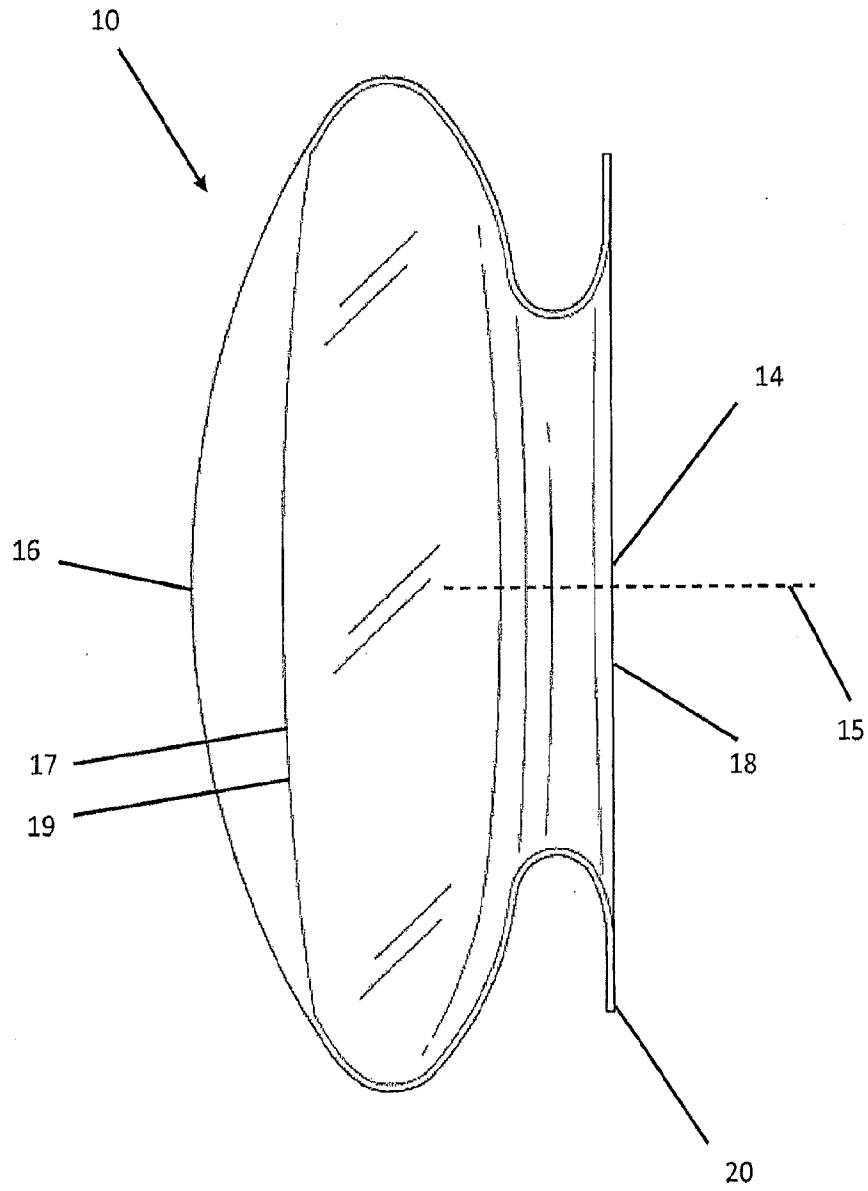

FIG. 2

3/7

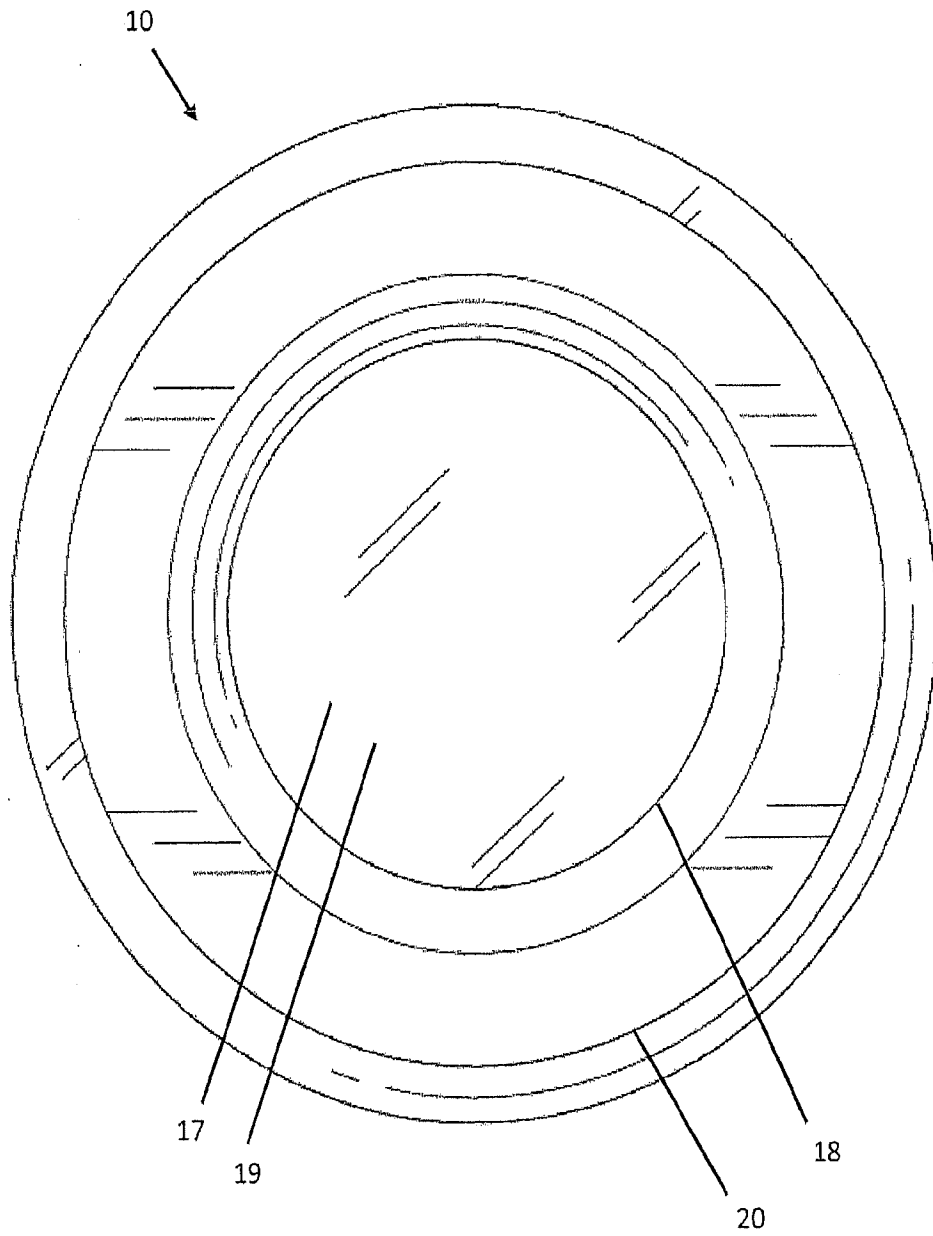

FIG. 3

4/7

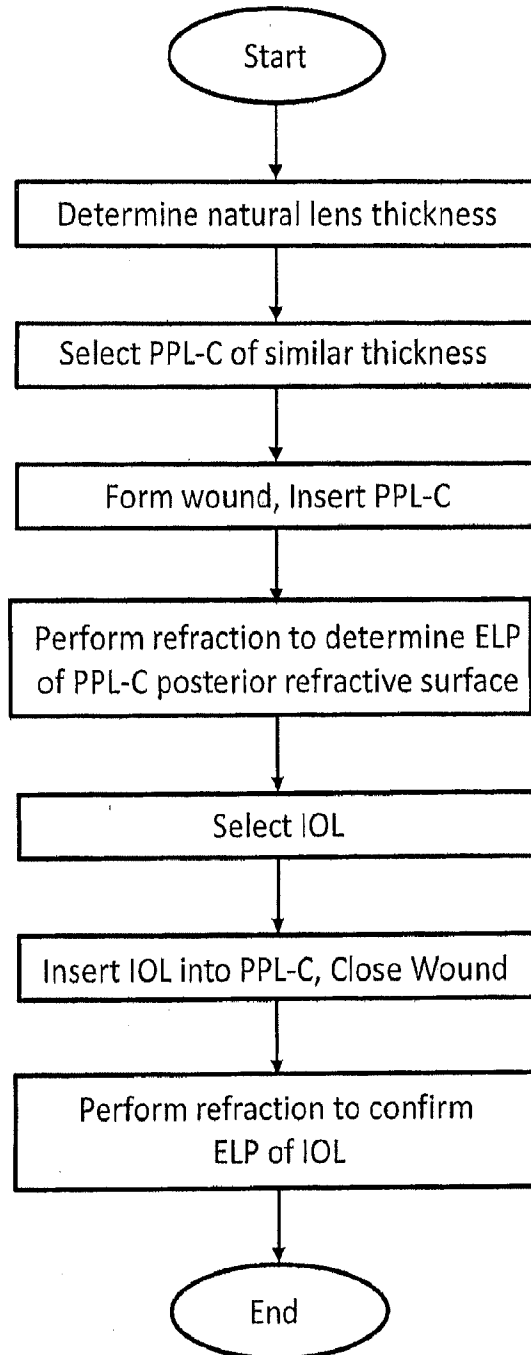

FIG. 4

5/7

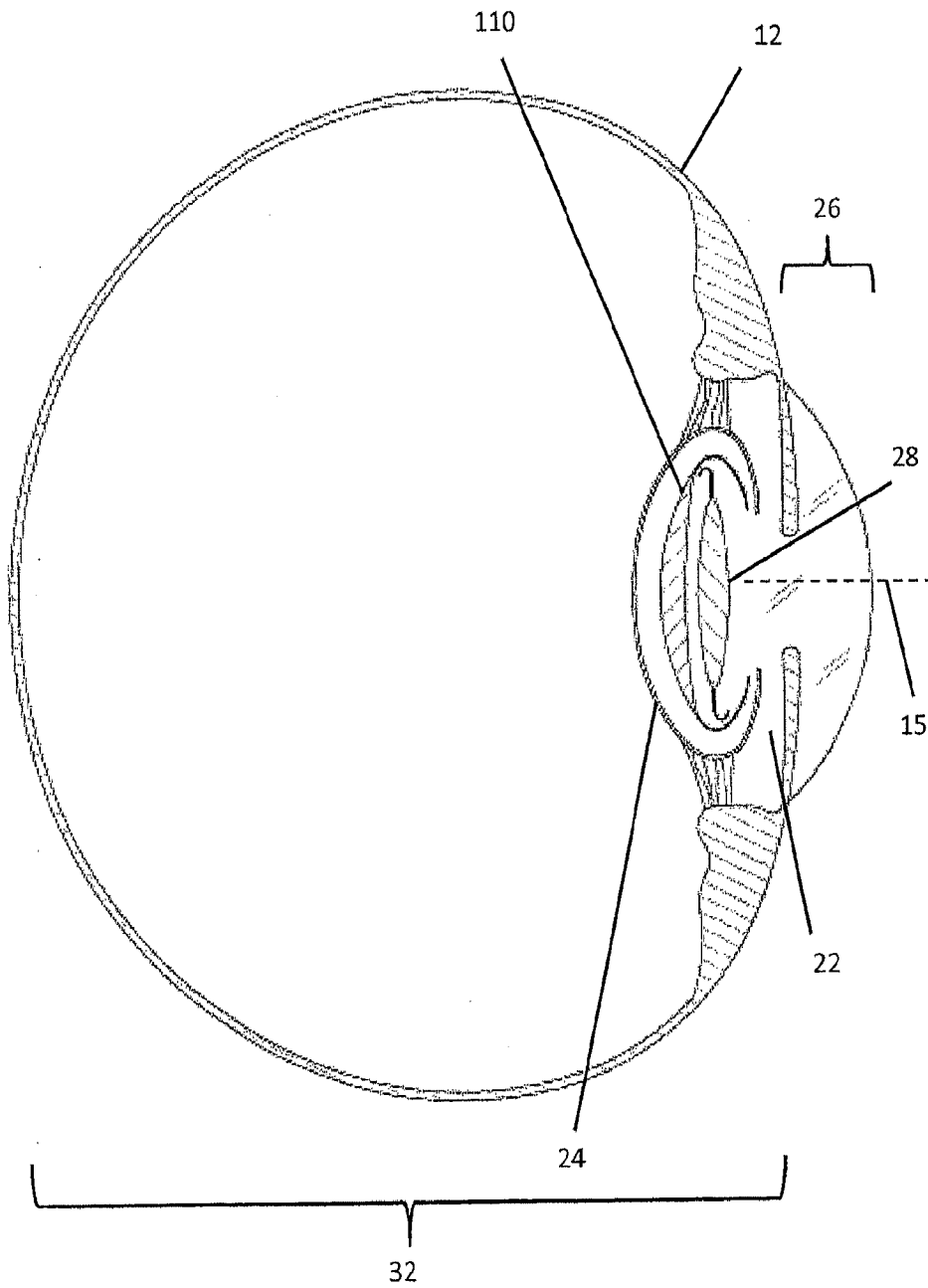

FIG. 5

6/7

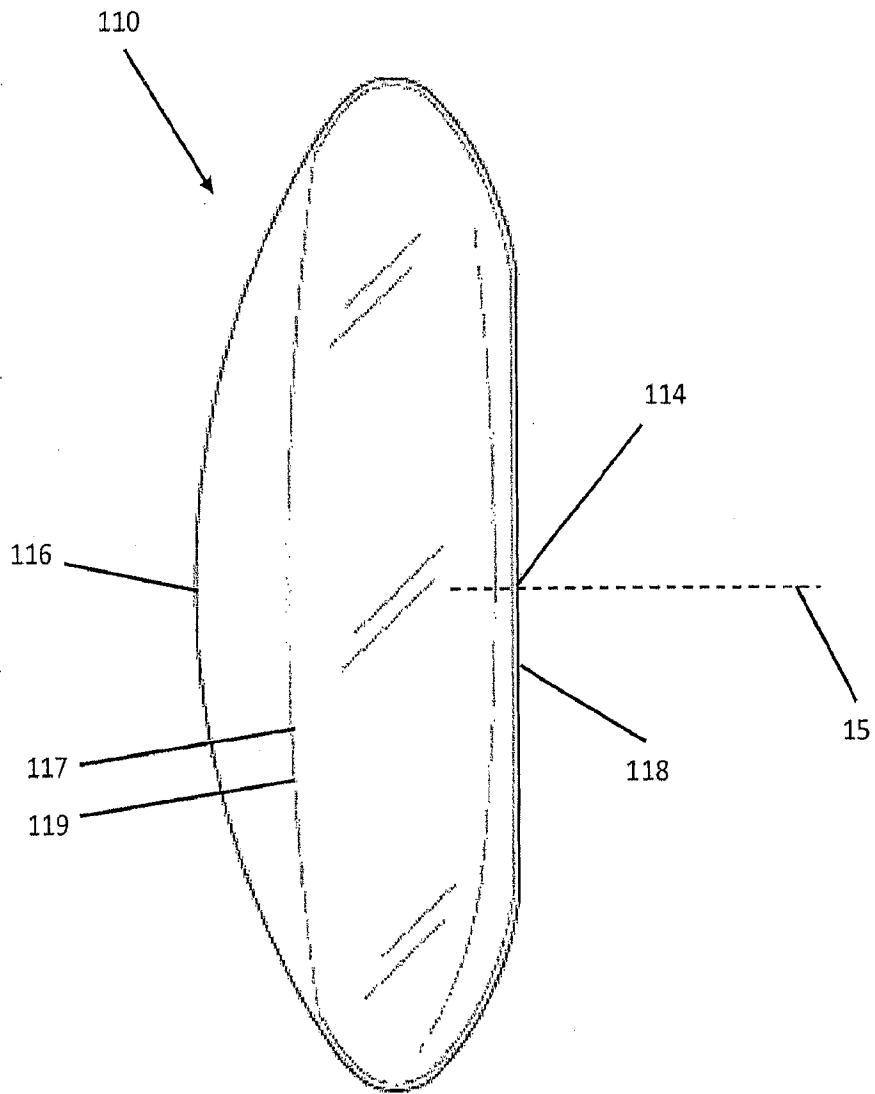

FIG. 6

7/7

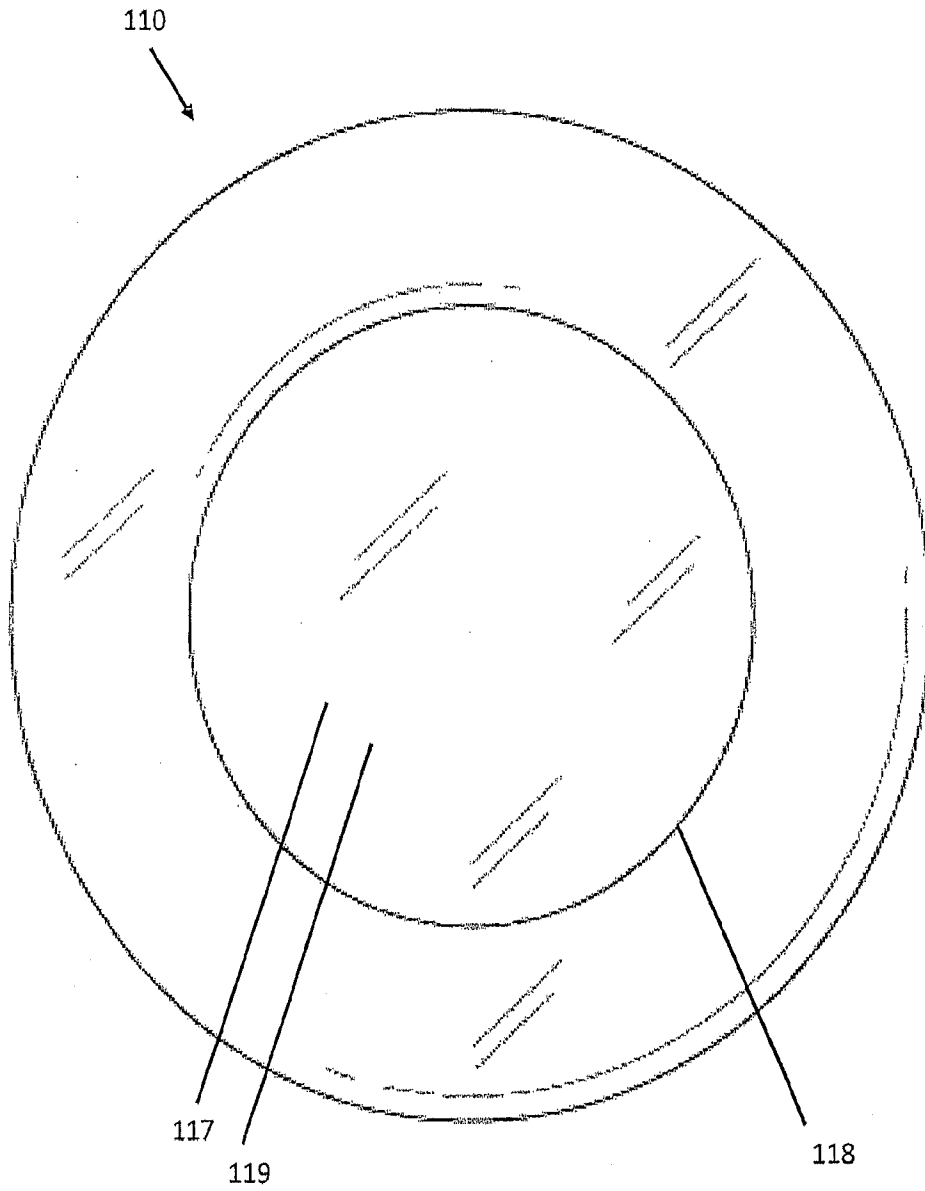

FIG. 7

INTERNATIONAL SEARCH REPORT

International application No
PCT/US2013/026820

A. CLASSIFICATION OF SUBJECT MATTER
INV. A61F2/16
ADD.
According to International Patent Classification (IPC) or to both national classification and IPC

B. FIELDS SEARCHED
Minimum documentation searched (classification system followed by classification symbols)
A61F

Documentation searched other than minimum documentation to the extent that such documents are included in the fields searched

Electronic data base consulted during the international search (name of data base and, where practicable, search terms used)
EPO-Internal, WPI Data

C. DOCUMENTS CONSIDERED TO BE RELEVANT

Category*	Citation of document, with indication, where appropriate, of the relevant passages	Relevant to claim No.
X	EP 2 412 337 A1 (SOURDILLE PHILIPPE [FR]) 1 February 2012 (2012-02-01) abstract; figures -----	1-6,9,10
X	EP 0 337 390 A2 (CESKOSLOVENSKA AKADEMIE VED [CS]) 18 October 1989 (1989-10-18) column 4, line 1 - line 14; claim 14; figures 1,2,5 -----	1-5,9,10
X	US 2007/032868 A1 (WOODS RANDALL [US]) 8 February 2007 (2007-02-08) paragraphs [0027] - [0029], [0050]; figures 3,4,8-10 -----	1-10
X	US 2004/082993 A1 (WOODS RANDALL [US]) 29 April 2004 (2004-04-29) paragraphs [0050], [0084]; claim 32; figures 20-22 -----	1-10
	-/--	

Further documents are listed in the continuation of Box C.

See patent family annex.

* Special categories of cited documents :

- "A" document defining the general state of the art which is not considered to be of particular relevance
- "E" earlier application or patent but published on or after the international filing date
- "L" document which may throw doubts on priority claim(s) or which is cited to establish the publication date of another citation or other special reason (as specified)
- "O" document referring to an oral disclosure, use, exhibition or other means
- "P" document published prior to the international filing date but later than the priority date claimed

"T" later document published after the international filing date or priority date and not in conflict with the application but cited to understand the principle or theory underlying the invention

"X" document of particular relevance; the claimed invention cannot be considered novel or cannot be considered to involve an inventive step when the document is taken alone

"Y" document of particular relevance; the claimed invention cannot be considered to involve an inventive step when the document is combined with one or more other such documents, such combination being obvious to a person skilled in the art

"&" document member of the same patent family

Date of the actual completion of the international search

23 May 2013

Date of mailing of the international search report

31/05/2013

Name and mailing address of the ISA/

European Patent Office, P.B. 5818 Patentlaan 2
NL - 2280 HV Rijswijk
Tel. (+31-70) 340-2040,
Fax: (+31-70) 340-3016

Authorized officer

Neumann, Elisabeth

INTERNATIONAL SEARCH REPORT

International application No
PCT/US2013/026820

C(Continuation). DOCUMENTS CONSIDERED TO BE RELEVANT		
Category*	Citation of document, with indication, where appropriate, of the relevant passages	Relevant to claim No.
X	US 2005/085907 A1 (HANNA KHALIL [FR]) 21 April 2005 (2005-04-21) paragraph [0066]; figure 10A -----	1-5,9,10

INTERNATIONAL SEARCH REPORT

International application No.
PCT/US2013/026820

Box No. II Observations where certain claims were found unsearchable (Continuation of item 2 of first sheet)

This international search report has not been established in respect of certain claims under Article 17(2)(a) for the following reasons:

1. Claims Nos.: 11-14
because they relate to subject matter not required to be searched by this Authority, namely:
Rule 39.1(iv) PCT - Method for treatment of the human or animal body by surgery

2. Claims Nos.:
because they relate to parts of the international application that do not comply with the prescribed requirements to such an extent that no meaningful international search can be carried out, specifically:

3. Claims Nos.:
because they are dependent claims and are not drafted in accordance with the second and third sentences of Rule 6.4(a).

Box No. III Observations where unity of invention is lacking (Continuation of item 3 of first sheet)

This International Searching Authority found multiple inventions in this international application, as follows:

1. As all required additional search fees were timely paid by the applicant, this international search report covers all searchable claims.

2. As all searchable claims could be searched without effort justifying an additional fees, this Authority did not invite payment of additional fees.

3. As only some of the required additional search fees were timely paid by the applicant, this international search report covers only those claims for which fees were paid, specifically claims Nos.:

4. No required additional search fees were timely paid by the applicant. Consequently, this international search report is restricted to the invention first mentioned in the claims; it is covered by claims Nos.:

Remark on Protest

- The additional search fees were accompanied by the applicant's protest and, where applicable, the payment of a protest fee.
- The additional search fees were accompanied by the applicant's protest but the applicable protest fee was not paid within the time limit specified in the invitation.
- No protest accompanied the payment of additional search fees.

INTERNATIONAL SEARCH REPORT

Information on patent family members

International application No PCT/US2013/026820

Patent document cited in search report	Publication date	Patent family member(s)	Publication date	
EP 2412337	A1	01-02-2012	EP 2412337 A1 FR 2963229 A1	01-02-2012 03-02-2012

EP 0337390	A2	18-10-1989	CA 1325699 C CS 8802470 A1 DE 68904925 D1 DE 68904925 T2 EP 0337390 A2 JP 2726094 B2 JP H0211134 A US 4963148 A	04-01-1994 12-02-1990 25-03-1993 26-08-1993 18-10-1989 11-03-1998 16-01-1990 16-10-1990

US 2007032868	A1	08-02-2007	US 2007032868 A1 WO 2007019061 A2	08-02-2007 15-02-2007

US 2004082993	A1	29-04-2004	AT 451079 T CA 2503961 A1 CA 2768127 A1 EP 1562521 A2 EP 2161003 A1 EP 2295009 A1 US 2004082993 A1 US 2004111153 A1 US 2006212116 A1 US 2011035001 A1 US 2012046744 A1 WO 2004037127 A2	15-12-2009 06-05-2004 06-05-2004 17-08-2005 10-03-2010 16-03-2011 29-04-2004 10-06-2004 21-09-2006 10-02-2011 23-02-2012 06-05-2004

US 2005085907	A1	21-04-2005	NONE	
