

(19) World Intellectual Property Organization  
International Bureau



(43) International Publication Date  
3 July 2008 (03.07.2008)

PCT

(10) International Publication Number  
**WO 2008/078181 A1**

(51) International Patent Classification:

C09D 5/00 (2006.01) F16B 5/00 (2006.01)  
C09D 127/12 (2006.01) E04F 15/04 (2006.01)  
E04F 15/02 (2006.01)

(21) International Application Number:

PCT/IB2007/004149

(22) International Filing Date:

19 December 2007 (19.12.2007)

(25) Filing Language:

Dutch

(26) Publication Language:

English

(30) Priority Data:

2006/0643 22 December 2006 (22.12.2006) BE  
2007/0045 2 February 2007 (02.02.2007) BE

(71) Applicant (for all designated States except US): **FLOOR-  
ING INDUSTRIES LIMITED, SARL** [IE/LU]; 10b, rue  
des Mérovingiens (ZI Bourmicht), L-8070 Bertrange (LU).

(72) Inventor; and

(75) Inventor/Applicant (for US only): **SEGAERT, Martin**  
[BE/BE]; Tiendelaan 3, B-8900 Ieper (BE).

(74) Agents: **DONNÉ, E.** et al.; Bureau M.F.J. Bockstael nv.,  
Arenbergstraat 13, B-2000 Antwerpen (BE).

(81) Designated States (unless otherwise indicated, for every  
kind of national protection available): AE, AG, AL, AM,

AT, AU, AZ, BA, BB, BG, BH, BR, BW, BY, BZ, CA, CH,  
CN, CO, CR, CU, CZ, DE, DK, DM, DO, DZ, EC, EE, EG,  
ES, FI, GB, GD, GE, GH, GM, GT, HN, HR, HU, ID, IL,  
IN, IS, JP, KE, KG, KM, KN, KP, KR, KZ, LA, LC, LK,  
LR, LS, LT, LU, LY, MA, MD, ME, MG, MK, MN, MW,  
MX, MY, MZ, NA, NG, NI, NO, NZ, OM, PG, PH, PL,  
PT, RO, RS, RU, SC, SD, SE, SG, SK, SL, SM, SV, SY,  
TJ, TM, TN, TR, TT, TZ, UA, UG, US, UZ, VC, VN, ZA,  
ZM, ZW.

(84) Designated States (unless otherwise indicated, for every  
kind of regional protection available): ARIPO (BW, GH,  
GM, KE, LS, MW, MZ, NA, SD, SL, SZ, TZ, UG, ZM,  
ZW), Eurasian (AM, AZ, BY, KG, KZ, MD, RU, TJ, TM),  
European (AT, BE, BG, CH, CY, CZ, DE, DK, EE, ES, FI,  
FR, GB, GR, HU, IE, IS, IT, LT, LU, LV, MC, MT, NL, PL,  
PT, RO, SE, SI, SK, TR), OAPI (BF, BJ, CF, CG, CI, CM,  
GA, GN, GQ, GW, ML, MR, NE, SN, TD, TG).

Declarations under Rule 4.17:

- as to applicant's entitlement to apply for and be granted a patent (Rule 4.17(ii))
- as to the applicant's entitlement to claim the priority of the earlier application (Rule 4.17(iii))
- of inventorship (Rule 4.17(iv))

Published:

- with international search report
- before the expiration of the time limit for amending the claims and to be republished in the event of receipt of amendments

(54) Title: FLOOR PANEL WITH A MOISTURE SEALED EDGE REGION AND METHOD FOR MANUFACTURING THE FLOOR PANELS

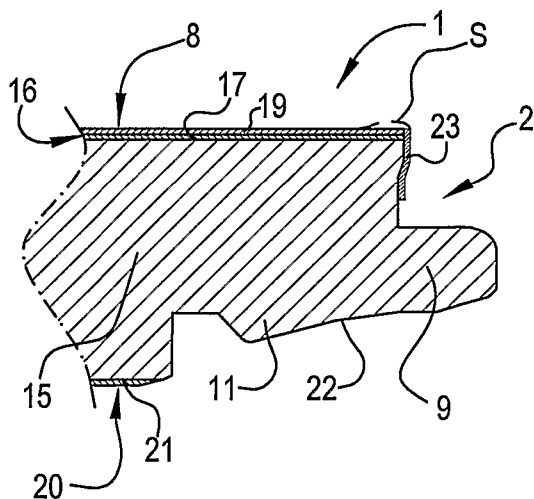

(57) Abstract: Floor panel of the type comprising a single- or multi- part substrate (15) and a top layer (16) and having, at least at two opposite sides (2-3), profiled edge regions (6), said regions comprising at least coupling parts (7), wherein said substrate (15) consists at least partially of wood or wood-based material, characterized in that at least a portion of the surface (22-22A) of said profiled edge regions (6), more particularly a portion that is formed of said wood or wood-based material, is provided with an active agent (23) with moisture-repellent effect, wherein said active agent (23) comprises a fluorinated polymer or copolymer.

WO 2008/078181 A1

FLOOR PANEL WITH A MOISTURE SEALED EDGE REGION AND METHOD FOR MANUFACTURING THE FLOOR PANELS

---

This invention relates to floor panels, and the  
5 invention also relates to a method for manufacturing floor panels.

More particularly, the invention relates to floor panels of the type which comprises a single- or multi-part  
10 substrate consisting at least partially of wood-based material, in particular of MDF or HDF (Medium Density Fiberboard or High Density Fiberboard), and which floor panels have a top layer, such as prefabricated parquet or veneer parquet with a top layer usually being made on  
15 the basis of wood, or such as laminate floor panels usually having a top layer on the basis of synthetic material.

It is known that such floor panels can be applied for  
20 forming a floating floor covering. Herein, these floor panels during installation are coupled at their edges, either by means of a classical tongue and groove connection, wherein these latter possibly are glued into each other, or by means of mechanical coupling parts  
25 providing for a mutual locking of the floor panels, for example, in horizontal as well as in vertical direction, as described, for example, in the International Patent Application WO 97/47834.

30 Floor panels of the above-mentioned type show the disadvantage that they easily take up moisture, which as such may lead to a variety of undesired effects, such as upstanding edges or premature wear.

35 The present invention relates to an improved floor panel of the above type. To this end, the invention, according

to its first aspect, relates to a floor panel of the type comprising a single- or multi-part substrate and a top layer and having, at least at two opposite sides, profiled edge regions, said regions comprising at least 5 coupling parts, wherein said substrate consists at least partially of wood or wood-based material, with the characteristic that at least a portion of the surface of said profiled edge regions is provided with an active agent with moisture-repellent effect, wherein said 10 active agent comprises a fluorinated polymer or copolymer. Preferably, said portion relates to a portion formed of said wood or wood-based material. Still better, said coupling parts are made in one piece with said substrate and therefore at least these coupling 15 parts consist of said wood or wood-based material.

By wood-based material, in the above, for example, materials are intended consisting of wood flakes, wood chips or wood fibers, which are connected by a binding 20 agent. More particular, materials are intended which are selected from the group of OSB (Oriented Strand Board), particle board and fiber board, such as, for example, MDF or HDF (Medium or High Density Fiberboard).

25 The inventors have found that by means of such active agents a good moisture-repellent effect can be obtained at the surface of the profiled edge regions. In particular, they have found that this effect can also be obtained on wood or wood-based material. Even with 30 porous materials, such as MDF or HDF, which are known for their water- or moisture-absorbing features, a proper moisture-repellent effect may be obtained.

For said active agent, use can be made of a fluorinated 35 polymer, or copolymer, of methacrylate. Thus, for example, in a preferred embodiment good results may be

achieved with perfluoroalkyl methacrylic copolymer.

Said active agent preferably is present at the surface as a layer or a film, the thickness of which preferably is 0.1 to 100 micrometer and still better 0.1 to 10 micrometer, and which either has or has not penetrated up into the material of the substrate. Depending on the desired function of the film, also layers with a thickness between 10 and 100 micrometer can be applied.

10

The active agent preferably covers at least 80 percent, and preferably 95 percent, and still better the entire surface of the respective profiled edge regions. It is clear that preferably all sides of the floor panel, or in other words the entire periphery of the floor panel, are provided with said active agent, with the intention of making them waterproof or water-tight, although it is not excluded that only the aforementioned two opposite sides are provided with such active agent. At the other sides of the floor panel then, in view of obtaining waterproofness or water-tightness of these sides, other measures may be performed, such as, for example, those known from WO 2004/016422, or such as the application of a separate sealing strip, such as known from WO 03/087497.

20  
25

In general, it is noted that said surface of the profiled edge regions preferably is provided with such an amount of active agent that a complete sealing against water and moisture is obtained at this surface. Such floor panels may be installed in humid rooms, such as bathrooms.

30

The invention is particularly useful with laminate floor panels. Such floor panels may have various constructions.

35

Laminate floor panels comprise at least a substrate, a printed decor, as well as a top layer, wherein the top layer preferably is made on the basis of synthetic material. For example, the top layer may consist of a number of carrier sheets, for example, of paper, which are provided with resin, for example, a melamine resin, such as melamine formaldehyde. In such case, the laminate preferably is made as a so-called "DPL" (Direct Pressure Laminate), wherein the top layer is pressed directly on the core, or so-called "HPL" (High Pressure Laminate), wherein the top layer as such is obtained by means of a press treatment before the top layer as a whole is provided on the core. Also, other possibilities for forming such top layer are possible, for example, by using foils, by providing a substance to be hardened or solidified, such as a varnish or the like, or in any other manner. The decor can be formed by a pattern which either is printed directly on the core, with the possible intermediary of a primer, or is printed on one or more of said carrier sheets or on said foil.

By applying said top layers, and in particular said top layers on the basis of synthetic material, a certain waterproofness or water-tightness can be obtained already at the upper side or decorative side of laminate floor panels. However, at the edges where such floor panels can be coupled together, there is a zone where moisture possibly could penetrate into the substrate via the profiled edge regions. Such penetration of moisture may lead to swelling of the substrate and a resulting formation of upstanding edges at the top layer. With the floor panel of the invention, a completely moisture-tight or water-tight panel may be obtained and thus the risk of the formation of such upstanding edges is minimized. It is noted that the formation of upstanding

edges, whether or not as a result of the penetration of moisture into the substrate, can also be minimized in other floor panels than laminate floor panels by means of said active agents. For example, these agents may also be applied in floor panels consisting of so-called "engineered wood". In such floor panels, the top layer may be provided with a layer of varnish or lacquer, which as such already has a sealing effect. By providing, by means of the active agents of the invention, a moisture-repellent effect at the edges as well, a totally encapsulated and moisture-tight panel is obtained.

It is clear that, as aforementioned, the coupling of laminate floor panels or other floor panels may be performed either by means of a classical tongue and groove connection, wherein these possibly are glued into each other, or by means of mechanical coupling parts providing in a mutual locking of the floor panels in horizontal as well as in vertical direction, for example, as described in the International Patent Application WO 97/47834. A treatment is of interest in particular for such mechanical coupling parts, as, when installing such floor panels, no glue, which as such may have a sealing effect, must be applied for effecting the coupling.

Further, it is noted that according to the invention it is possible that the floor panels comprise a substrate consisting of MDF or HDF and that these floor panels, by means of said sealing effect of the active agent, can be provided with waterproof edge regions independently from the amount of binding agent applied in the production of the respective MDF/HDF substrate. For example, a floor panel with a substrate which as such is of a lesser quality, such as MDF/HDF with a high swelling rate, for

example, a swelling rate of more than 20% (as measured according to the EN13329 Annex G standard), still may have waterproof edge regions.

5 Said active agent may be a solid product which is obtained from a mixture, more particularly a dispersion or an emulsion, wherein this mixture contains at least water and said active agent, wherein the active agent is a residue obtained by vaporization or drying of said  
10 mixture at the surface of the profiled edge regions. An example of a possible mixture is a mixture comprising at least the product commercially available under the name of Zonyl 7840 of Dupont. This commercial product as such is a water-based dispersion of perfluoroalkyl  
15 methacrylic copolymer, wherein this dispersion comprises approximately 30 weight percent of solid matter of the copolymer and 70 weight percent of water. Other commercially available products are Zonyl 9361, Zonyl 9338, Zonyl 9027, Zonyl 210, Zonyl 225, Zonyl 321, Zonyl  
20 329 und TE3887, all from Dupont. The inventors have performed tests with various of said commercial products and found that all products offered good results. Zonyl 7840 led to the most satisfactory results and had a very high degree of water-tightness even on a MDF or HDF  
25 substrate. Even when this commercial product was further thinned with water, good results were obtained.

According to a second independent aspect, the invention relates to a method for manufacturing a floor panel,  
30 wherein this floor panel is of the type comprising at least a single- or multi-part substrate and a top layer and having, at least at two opposite sides, profiled edge regions, said regions comprising at least coupling parts, wherein said substrate consists at least  
35 partially of wood or wood-based material, and wherein at least a portion of the surface of said profiled edge

regions is provided with an active agent with moisture-repellent features, with the characteristic that said active agent is provided on the respective surface in the form of an emulsion or dispersion formed at least by  
5 water and the active agent provided therein. Due to the fact that the active agent is provided in an emulsion or dispersion, many possibilities in respect to ways of application of this emulsion or dispersion are opened. Also, it is obtained that certain active agents, for  
10 example, agents having a high viscosity or possibly as such being solid materials at room temperature, still can be provided on said surface in a liquid form.

For an optimum effect of the active agent, preferably at  
15 least the entire respective profiled edge region is treated with said emulsion or dispersion, and possibly a portion of said top layer.

It is also possible to select an organic emulsion or  
20 dispersion, for example, an emulsion or dispersion comprising isopropyl alcohol, instead of a water-based emulsion or dispersion. Preferably, however, due to health aspects, an emulsion or dispersion is applied which is free from volatile organic components (VOCs),  
25 as may be the case with said water-based emulsion or dispersion. Said emulsion preferably has a solid matter content of at least 15%, and still better at least 20%. An optimum value for the solid matter content is at least 30%. Preferably, such emulsion or dispersion  
30 consists for at least 60% of water.

Preferably, said emulsion or dispersion comprises at least a chemically modified acrylate or methacrylate as an active agent, wherein the modification preferably  
35 increases the hydrophobicity of the active agent. Such modified agents result in a good moisture-repellent

effect on the profiled edge regions already with low concentrations in the dispersion or emulsion. Thus, for example, already with a dry matter content in the dispersion or emulsion of less than 45 weight percent, a  
5 very good result can be achieved. Moreover, a dispersion or emulsion in low concentrations is simple to apply in different manners. An example of a modified acrylate or methacrylate is a fluorinated or fluorochemical copolymer of acrylate or methacrylate.

10

Other possible emulsions or dispersions comprise, for example, at least an UV lacquer, preferably a monomer-free UV lacquer. Still another possibility is to use a water-based copolymer of ethylene acrylic acid. This  
15 kind of products may form a very stable hydrophobic layer on the profiled edge regions. These water-based copolymers preferably comprise dry matter contents of 20% or more, for example, of 30%. An example of such products is the commercially available MichemPrime 5930.

20

According to the second aspect, the emulsion or dispersion may have any pH value, lower than, equal to or higher than 7. Preferably, an emulsion or dispersion in an acidic medium is applied.

25

It is clear that the method of the second aspect can be applied for manufacturing floor panels with the characteristics of the first aspect, in other words, that therein an agent is used for the active agent as  
30 described herein above by means of the first aspect.

The method of the second aspect preferably also comprises the step of performing a forced drying of the profiled edge regions treated with the emulsion or  
35 dispersion, wherein this drying preferably substantially will take place directly after providing said emulsion

or dispersion, more particularly within the first minute following the application thereof. Such fast, forced drying prevents that the water from the emulsion or dispersion gets the chance to penetrate into the  
5 aforementioned substrate and in this manner possibly already might create upstanding edges.

Said emulsion or dispersion preferably is provided on said surface in at least two layers, wherein the layer  
10 provided first either is dried, whether or not at least partially, before providing the second layer. Of course, a drying, more particularly a forced drying can be performed after providing each layer.

15 The above-mentioned monomer-free UV lacquers have the advantageous feature that they are simpler to cure than UV lacquers comprising monomers and that they penetrate less deeply into porous materials, such as MDF and HDF. Floor panels which are treated with such lacquers show  
20 particular advantages. According to a third independent aspect, the invention thus also relates to a floor panel of the type comprising a single- or multi-part substrate and a top layer and having, at least at two opposite sides, profiled edge regions, said regions comprising at  
25 least coupling parts, wherein said substrate consists at least partially of wood or wood-based material, with the characteristic that at least a portion of the surface of said profiled edge regions, more particularly a portion formed of said wood or wood-based material, is provided  
30 with a hardened monomer-free UV lacquer.

According to a first preferred embodiment of the third aspect, the respective profiled edge regions comprise at least a surface which is made as a chamfer, more  
35 particularly as a bevel, wherein this chamfer is provided with a decorative and/or transparent coating

formed by means of said hardened monomer-free UV lacquer. By means of such UV lacquer, a better decorative coating can be obtained. For example, a better covering of said surface may be obtained.

5

According to a second preferred embodiment, said monomer-free UV lacquer is at least partially provided on the surface of the coupling parts in order to form a moisture-repellent coating. Due to the fact that the UV  
10 lacquer is monomer-free and therefore penetrates less deeply into the respective surface, it is obtained that the risk of obtaining upstanding edges already during the manufacture of the floor panels is minimized.

15 Said UV lacquer preferably is a water-base lacquer or water-based lacquer, which is hardened.

As an alternative for the agents with a moisture-repellent effect mentioned above in the first and third  
20 aspects, also hot melt adhesives, whether or not solidified, can be applied. In English, such hot melt adhesive is known better under the denomination of "hot melt glue" and can be applied on a portion of the profiled edge regions in a simple manner. Thus, the  
25 invention according to its fourth independent aspect relates to a floor panel of the type comprising at least a single- or multi-part substrate and a top layer and having, at least at two opposite sides, profiled edge regions, said regions comprising at least coupling  
30 parts, wherein said substrate consists at least partially of wood or wood-based material, with the characteristic that at least a portion of the surface of said profiled edge regions, more particularly a portion formed of said wood or wood-based material, is provided  
35 with a preferably solidified hot melt glue.

Such hot melt glues may concern chemical compositions which are free of solvents. These "hot melt" glues may form very strong connections, and may do so very fast after the glue has cooled. Moreover, they are easy to  
5 handle and/or to provide, as a consequence of which a smooth and efficient manufacture of the floor panels of the invention can be achieved in a simple manner. According to the invention, for example, polypropylene (PP), polysulfone, polyurethane (PUR), polyetherimide  
10 and/or polyolefine can be applied as hot melt glue.

The inventors have found that by means of a hot melt glue, such as the aforementioned type, a water-tight material layer can be formed at least on a portion of  
15 the profiled edge regions. In this application, in particular the polyurethane hot melt glues are of interest, as in particular these hot melt glues can be composed such that they show a short opening time. By the term "opening time", in the terminology the time is  
20 indicated which is necessary for the respective glue to crystallize again from the molten condition in which it has been applied, or in other words, to solidify. Thus, for example, opening times can be reached amounting to 30 minutes or less. They may also amount to less than 10  
25 minutes and even less than 5 minutes. Of course, this opening time depends on the amount of glue which has been provided, and possibly on the method by which the glue has been provided. In a preferred embodiment, the amount of glue which has been provided, the temperature  
30 and the method by which the glue has been provided on the profiled edge regions have been chosen such that the opening time of the glue amounts to less than 10 minutes, and still better to less than 5 minutes. It is not excluded that short opening times are also achieved  
35 with other hot melt glues than polyurethane glues. The utilization of hot melt glues with low opening times is

particularly interesting when a fast production must be obtained.

Another interesting, however, also not required, feature  
5 for hot melt glues which can be applied to the floor  
panel of the fourth aspect, is that the hot melt glue at  
its application temperature, preferably between 150°C  
and 200°C, depending on the glue, has a low viscosity.  
Thus, for example, this viscosity may be lower than 250  
10 Pas or 100 Pas. Preferably, hot melt glues are used  
having a viscosity of less than 10 Pas and still better  
less than 1 Pas at their application temperature. These  
low viscosities also increase the efficiency and/or the  
possibilities by which the hot melt glue can be applied.  
15 Moreover, the inventors have found that with such hot  
melt glues a good adherence with wood or wood-based  
material and in particular with MDF or HDF can be  
obtained.

20 According to a first possibility, said hot melt glue is  
at least partially applied on the surface of the  
coupling parts in order to thereby form a moisture-  
repellent coating.

25 According to a second possibility, said solidified hot  
melt glue is present at least over part of the length of  
one or more of the respective profiled edge regions as a  
strip underneath the upper edge of the floor panel. Such  
strip may minimize the risk of the occurrence of  
30 standing-up edges as a result of the penetration of  
moisture into the profiled edge regions.

Possibly, the hot melt glue of the fourth aspect may  
also be selected such that it has a certain elasticity  
35 in solidified condition. Thus, for example, a hot melt  
glue, such as a polyurethane glue, can be chosen

allowing for a stretching of more than 500 percent. It is even possible to achieve a stretching of more than 1000 percent. A hot melt glue which can show this high stretching, may be utilized, amongst others, in an embodiment according to said second possibility as a physical sealing of the joint between two floor panels. Such sealing preferably is under permanent tension or preferably is always compressed, such that with a possible drifting-apart of the floor panels, a reliable sealing will be maintained.

An example of a possible hot melt glue is the commercially available Irostick M 8304 from the Huntsman Company. According to manufacturer's data, this polyurethane hot melt glue has a viscosity of 14 to 20 Pas at 190°C and a short opening time.

With the intention of better showing the characteristics of the invention, hereafter, as an example without any limitative character, several preferred embodiments are described, with reference to the accompanying drawings, wherein:

Figure 1 represents a floor panel according to the invention;

Figure 2 represents this floor panel in a cross-section according to the line II-II represented in figure 1;

Figure 3, for a variant, represents the region indicated by F3 in figure 2 at a larger scale;

Figure 4, in a similar view, represents a variant;

Figure 5 schematically represents a method according to the invention;

Figure 6 represents a cross-section according to the line VI-VI represented in figure 5.

Figure 1 shows an oblong rectangular floor panel 1, which is provided with two pairs of opposite sides, 2-3 and 4-5, with profiled edge regions 6 comprising mechanical coupling parts 7.

5

Figure 2 illustrates that the applied coupling parts 7 allow a mutual locking of two of such floor panels 1 in a horizontal direction H as well as in a vertical direction V. For the locking in vertical direction V, i.e., in a direction perpendicular to the upper side 8 of the floor panel 1, the coupling parts 7 represented here substantially are made in the form of a tongue 9 and a groove 10. The locking in horizontal direction H, i.e., in a direction perpendicular to said vertical direction V and in the plane of figure 2, in this case is obtained by providing locking elements in the form of a protrusion 11 at the underside of the tongue 9 and a recess 12 in the lower lip of the groove 10. When coupling two of such floor panels 1, the locking elements 11-12 cooperate and prevent that the floor panels 1 move away from each other. This is illustrated by means of the floor panel 1 represented by dashed line 13, wherein it is clearly visible that an overlap 14 may exist between the not-coupled contours of the groove 10 and the tongue 9, more particularly between the contours of the respective locking elements 11-12. By means of such overlap 14, when coupling two floor panels, a so-called pretension may be effected. The concept of pretension is known as such from WO 97/47834. Preferably, the applied mechanical coupling parts 7 result in a locking free from play of two of such floor panels in said horizontal direction H and vertical direction V, and still better the coupling parts 7 result in a locking free from play in all directions in the plane defined by said directions V and H.

10  
15  
20  
25  
30  
35

It is clear that the floor panels 1 of the invention may have any shape, such as a rectangular, square, hexagonal shape or the like, and may be provided with any coupling parts 7 as well.

5

The floor panel 1 represented in figures 1 and 2 relates to a laminate floor panel 1 comprising a substrate 15, wherein this substrate 13 entirely consists of a wood-based material, such as MDF or HDF. Moreover, said  
10 coupling parts 7 are made in one piece with this substrate 15. The floor panel 1 also comprises a top layer 16 on the basis of synthetic material. In this case, the top layer 16 relates to a so-called "DPL" layer, which, in this example, consists of a decorative  
15 layer 17 with a printed pattern 18 and a wear-resistant layer 19 provided thereon, such as a so-called overlay. The decorative layer 17 as well as the overlay 19 comprise a paper layer soaked in resin. Herein, the overlay further also comprises wear-resistant particles,  
20 such as corundum. At its bottom side 20, the floor panel 1 has a backing 21, which also comprises a paper layer soaked in resin.

The particularity of the floor panel from figures 1 and  
25 2 consists in that at least a portion of the surface 22 of the profiled edge regions 6 is provided with an active agent 23 rendering a moisture-repellent effect. According to the invention, the active agent 23 herein concerns a polymer or copolymer or a hardened monomer-free UV lacquer. The active agent 23 may also relate to  
30 a copolymer of ethylene acrylic acid. According to the fourth aspect of the invention, the agent 23 may also relate to a hot melt glue, whether or not solidified. Viewed in the cross-section of figure 2, the active  
35 agent 23 herein covers the entire profiled edge region 6.

In figure 2 is shown that the active agent 23 herein forms a layer or film with a certain thickness T. In this figure as well as in the figures 3 and 4 discussed in the following, this layer is illustrated schematically as a layer lying on top of the surface 22 of the profiled edge regions 6. It is clear that this layer in reality can have penetrated more or less or even completely into the surface 22 of the respective edge region 6. It is clear that preferably provisions will be made for restricting the amount of active agent 23 lying on top of the surface 22 to a minimum thickness T, for example, by applying an appropriate dilution, due to which the active agent 23 becomes better absorbed into the substrate 15. In this manner, it does not form an undue hindrance when coupling the respective edges 2-3 to a similar floor panel 1. It is noted that the thickness T of the film is represented in an exaggerated manner. In reality, the thickness T may be in the micron range.

Figure 3 shows a variant in which the active agent 23 covers the transition between the substrate 15 and the top layer 16, as well as a limited strip underneath the upper edge of the floor panel 1. In particular when applying said active agents 23, more particularly fluorinated polymers or copolymers or monomer-free UV lacquers, which, as aforementioned, are particularly efficient for forming a water-tight surface, the utilization of such active agents in the form of a strip is also very useful for classical laminate floor panels or other floor panels which are not specifically intended for being applied in humid rooms. In classical laminate floor panels, there is the disadvantage that, when cleaning them with a moist cloth, moisture is taken up into the substrate, as a result of which this latter

swells and the laminate top layer permanently is pushed upward next to the edges of the floor panels. As now by means of said active agents a particularly efficient sealing can be realized, it is impossible for moisture  
5 to penetrate into the substrate directly underneath the laminate top layer, by which said effect is precluded or at least minimized.

In dashed line S, it is also shown in figure 3 that the  
10 active agent 23 also may continue up onto the upper surface 8 of the floor panel 1. In general, one will strive to have the active agent 23 or monomer-free UV lacquer cover at least the transition between the substrate 15 and the top layer 16.

15

Figure 4 shows a variant, wherein the profiled edge regions 6 comprise at least a surface 22A which is realized as a chamfer 24, in this case, a bevel. As illustrated, the active agent 23 also can be provided on  
20 the surface 22A of this bevel 24. Possibly, the active agent 23 substantially can be provided solely on this surface 22A. In case that the agent 23 relates to a hardened monomer-free UV lacquer, this agent 23 also can be applied for forming a decorative and/or transparent  
25 coating on said surface 22A. However, it is not excluded that this surface is provided with another decorative layer extending above or underneath said active agent, however, this is not represented here.

30 Figure 5 schematically shows a method according to the invention, by which the floor panel 1 from figures 1 to 4 can be manufactured. Herein, said active agent 23 is applied on the surface 22-22A of the profiled edge regions 6 in the form of an emulsion or dispersion 25,  
35 which is at least formed by water and the active agent 23 provided therein. This may be performed, such as

here, by means of a sprinkling or spraying technique by means of a continuous vacuum application device, which will be described herein below. However, it is clear that any other technique may be applied, such as, for example, spraying on by means of a spray nozzle, application by means of rollers, spreading on, pouring on and the like.

In the example of figure 5, said emulsion or dispersion 26 is provided at least in two layers on the surface of the edge regions 6, wherein the first applied layer 26 is dried by means of a drying device 27 before the second layer 28 is applied. After completion of the application of the active agent 23, also a forced drying of the profiled edge regions 6 treated with the emulsion or dispersion 25 is performed by means of a drying device 29. Such drying may be performed, for example, as shown here by means of radiation, such as infrared or ultraviolet radiation. However, use can also be made of any other technique, such as by means of drying ovens or the technique of supplying warm air.

It is noted that the represented method relates to a continuous treatment, wherein the floor panel 1 is guided along spray heads 30 and the drying devices 27-29. Such treatment is easy to integrate in present-day manufacturing systems for floor panels.

Figure 6 schematically shows one of the spray heads 30 applied in the example. Herein, this relates to so-called "Schiele applicator heads", which, for example, are of the type known as such from DE 92 02 976 U1. Usually, such spraying heads 30 are applied for providing substances at the edges of panels in a continuous manner. To this aim, such spraying heads 30 have a so-called passage gap 31 adjoining closely,

practically without play, to the profiled edge region 6 to be treated. The substance 23-25 to be applied is supplied via flexible tubes 32 into the immediate proximity of the respective profiled edge regions 6, and  
5 potential excessive substance is directly suctioned off again by a suction conduit 33, such that the risk that the substance contaminates the decorative side or upper side 8 of the floor panel 1 is minimal. Due to the connection with flexible tubes 32 and 33, such spraying  
10 head 30 is easy to adjust or to position in respect to the edge 6 to be treated of the floor panel 1. It is noted that it is not excluded that the floor panel 1 is passed through the passage gap 31 of such spraying head 30 with its decorative side 8 directed downward.

15

It is clear that the method from figure 5 and the applicator head from figure 6 may also be applied for providing the water-based copolymer of ethylene acrylic acid mentioned in the introduction. However, this  
20 product preferably is applied at an increased temperature, for example, at more than 50°C or even at more than 80°C; possibly, after the application a post-heating can be performed in any manner, such as, for example, by infrared radiation. This post-heating may  
25 promote the distribution of the copolymer, such that possibly a layer may be formed on the entire surface or on part of the surface of the profiled edge regions. After forming this layer, possibly a forced cooling or drying can be applied.

30

Further, it is noted that the methods as represented in figures 5 and 6 primarily are of interest for manufacturing floor panels with the characteristics of the first or the third aspect. For providing hot melt  
35 glue, such as in a method for manufacturing floor panels with the characteristics of the fourth aspect,

preferably use is made of applicator heads designed in particular for this purpose. Applicator heads for hot melt glue are known as such and are applied, for example, when finishing edges of coated panels.

5 Preferably, the devices are applied which are known from EP 1 205 275. However, it is clear that for the efficiency of the manufacturing process, also in case the moisture-repellent agent relates to hot melt glue, the profiled edge regions, or at least the respective

10 portion of the profiled edge regions, are treated with this hot melt glue in a continuous process. Further, it is clear that a hot melt glue preferably is applied pure, in other words, is not applied as a suspension or emulsion.

15 Finally, in connection with the application in a continuous process, it is also noted that herein throughput speeds can be obtained which are higher than 80 m/min and/or even may amount to 150 m/min or more.

20 It is clear that in the examples of figures 2 to 4 and 6 the not-represented groove side 3-5 of the floor panel 1 preferably has undergone a similar treatment and that still better all sides 2-3-4-5 of the floor panel 1 are

25 provided with an active agent 23 and/or a monomer-free UV lacquer in any manner.

Possibly, indication means can be incorporated in the active agent in order to control whether this agent is

30 applied in a covering manner on the desired surface. Such indication means may consist of a colorant or a material which, for example, will light up when radiated with light or the like.

35 It is clear that the invention also relates to floor panels obtained by means of a method according to the

second aspect. In particular, it is clear that the invention according to a particular aspect also relates to a floor panel of the type comprising at least a single- or multi-part substrate 15 and a top layer 16 and having, at least at two opposite sides 2-3, profiled edge regions 6, said regions comprising at least coupling parts 7, wherein said substrate 15 consists at least partially of wood or wood-based material, with the characteristic that at least a portion of the surface 22-22A of said profiled edge regions, more particularly a portion formed of said wood or wood-based material, is provided with a copolymer of ethylene acrylic acid. Namely, the inventors have found that this agent may also accomplish a particularly effective hydrophobic effect on the profiled edge regions of such floor panel.

It is noted that the invention according to all its aspects, where it relates to floor panels as well as where it relates to methods, also can be applied for floor panels of which said substrate, instead of consisting at least partially of wood or wood-based material, consists at least partially of another water- or moisture-absorbing material. As mentioned in the introduction, the active agents surprisingly have a good moisture-repellent effect even with porous materials absorbing water or moisture to a high extent. Examples of another water- or moisture-absorbing material are plaster board or other chalk-based boards.

The present invention is in no way limited to the embodiments described as example and represented in the figures, on the contrary may such methods and floor panels be realized according to various variants, without leaving the scope of the invention.

Claims.

1. Floor panel of the type comprising a single- or multi-part substrate (15) and a top layer (16) and having, at least at two opposite sides (2-3), profiled edge regions (6), said regions comprising at least coupling parts (7), wherein said substrate (15) consists at least partially of wood or wood-based material, characterized in that at least a portion of the surface (22-22A) of said profiled edge regions (6), more particularly a portion that is formed of said wood or wood-based material, is provided with an active agent (23) with moisture-repellent effect, wherein said active agent (23) comprises a fluorinated polymer or copolymer.
2. Floor panel according to claim 1, characterized in that said active agent (23) relates to a fluorinated polymer, or copolymer, of methacrylate.
3. Floor panel according to claim 2, characterized in that said fluorinated copolymer of methacrylate relates to a perfluoroalkyl methacrylic copolymer.
4. Floor panel according to any of the preceding claims, characterized in that said active agent (23) covers at least 80%, and preferably at least 95%, and still better the entire surface (22) of the respective profiled edge regions (6).
5. Floor panel according to any of the preceding claims, characterized in that said active agent (23) is present on all edge regions (6) of the floor panel (1).
6. Floor panel according to any of the preceding claims, characterized in that the active agent (23) is a solid product obtained from a mixture, more particularly

a dispersion (25), wherein this mixture or this dispersion (25) contains at least water and said active agent (23), wherein the active agent (23) is a residue obtained by vaporization or drying of said mixture at  
5 the surface (22-22A) of the profiled edge regions (6).

7. Floor panel according to claims 3 and 5, characterized in that said mixture comprises at least the product commercially available under the name of  
10 Zonyl 7840 from Dupont.

8. Floor panel according to any of the preceding claims, characterized in that said surface (22-22A) of the profiled edge regions (6) is provided with such an  
15 amount of active agent (23) that a complete sealing against water and moisture is obtained at this surface (22-22A).

9. Method for manufacturing a floor panel, wherein  
20 this floor panel (1) is of the type comprising at least a single- or multi-part substrate (15) and a top layer (16) and having, at least at two opposite sides (2-3), profiled edge regions (6), said regions comprising at least coupling parts (7), wherein said substrate (15)  
25 consists at least partially of wood or wood-based material, and wherein at least a portion of the surface (22-22A) of said profiled edge regions (6) is provided with an active agent (23) with moisture-repellent features, characterized in that said active agent (23)  
30 is provided on the respective surface (22-22A) in the form of an emulsion or dispersion (25) formed by water and the active agent (23) provided therein.

10. Method according to claim 9, characterized in that  
35 said emulsion or dispersion (25) comprises at least a chemically modified acrylate or methacrylate as the

active agent (23), wherein the modification preferably increases the hydrophobicity of the active agent (23).

11. Method according to claim 10, characterized in that  
5 a fluorinated or fluorochemical copolymer of acrylate or methacrylate is applied as a modified acrylate or methacrylate.

12. Method according to any of the claims 9 to 11,  
10 characterized in that use is made of an emulsion or dispersion (23) in an acidic medium.

13. Method according to any of the claims 9 to 11,  
15 characterized in that it is applied for manufacturing a floor panel (1) according to any of the claims 1 to 8, in other words, that therein an agent, as defined in these claims 1 to 8, is used as the active agent (23).

14. Method according to any of the claims 9 to 13,  
20 characterized in that said emulsion or dispersion (25) comprises at least an UV lacquer, preferably comprises a monomer-free UV lacquer.

15. Method according to any of the claims 9 to 14,  
25 characterized in that the method also comprises the step of performing a forced drying of the profiled edge regions (6) treated with the emulsion or dispersion (25), wherein this drying preferably is performed substantially directly after the application of said  
30 emulsion or dispersion (25), more particularly within the first minute following the application thereof.

16. Method according to any of the claims 9 to 15,  
35 characterized in that said emulsion or dispersion (25) is provided on said surface (22-22A) in at least two layers (26-28), wherein the first-provided layer (26) is

dried, whether or not completely, before the second layer (28) is provided.

17. Floor panel of the type comprising at least a  
5 single- or multi-part substrate (15) and a top layer  
(16) and having, at least at two opposite sides (2-3),  
profiled edge regions (6), said regions comprising at  
least coupling parts (7), wherein said substrate (15)  
10 consists at least partially of wood or wood-based  
material, characterized in that at least a portion of  
the surface (22-22A) of said profiled edge regions (6),  
more particularly a portion formed of said wood or wood-  
based material, is provided with a hardened monomer-free  
UV lacquer (23).

15

18. Floor panel according to claim 17, characterized in  
that the respective profiled edge regions (6) comprise  
at least a surface (22A) made as a chamfer (24), more  
particularly a bevel, wherein this chamfer (24) is  
20 provided with a decorative and/or transparent coating  
formed by means of said hardened monomer-free UV lacquer  
(23).

19. Floor panel according to claim 17 or 18,  
25 characterized in that said hardened monomer-free UV  
lacquer (23) is provided at least partially on the  
surface (22) of the coupling parts (7) in order to  
thereby form a moisture-repellent coating.

30 20. Floor panel according to any of the claims 17 to  
19, characterized in that said UV lacquer is a water-  
based lacquer or water-base lacquer, which is hardened.

21. Floor panel of the type comprising at least a  
35 single- or multi-part substrate (15) and a top layer  
(16) and having, at least at two opposite sides (2-3),

profiled edge regions (6), said regions comprising at least coupling parts (7), wherein said substrate (15) consists at least partially of wood or wood-based material, characterized in that at least a portion of the surface (22-22A) of said profiled edge regions, more particularly a portion formed of said wood or wood-based material, is provided with a solidified hot melt glue.

22. Floor panel according to claim 21, characterized in that said solidified hot melt glue is provided at least partially on the surface (22) of the coupling parts in order to thereby form a moisture-repellent coating.

23. Floor panel according to claim 21 or 22, characterized in that said solidified hot melt glue is present at least over part of the length of one or more of the respective profiled edge regions as a strip underneath the upper edge of the floor panel.

24. Floor panel according to any of the claims 21 to 23, characterized in that said hot melt glue relates to a polyurethane hot melt glue preferably having an opening time of less than 5 seconds.

25. Floor panel according to any of the claims 1 to 8 or 17 to 24, characterized in that said substrate (15), instead of consisting at least partially of wood or wood-based material, consists at least partially of another water- or moisture-absorbing material.

26. Method according to any of the claims 9 to 16, characterized in that, instead of being applied for manufacturing floor panels (1) with a substrate (15) consisting at least partially of wood or wood-based material, it is applied for manufacturing floor panels (1) with a substrate (15) consisting at least partially

of another water- or moisture-absorbing material.

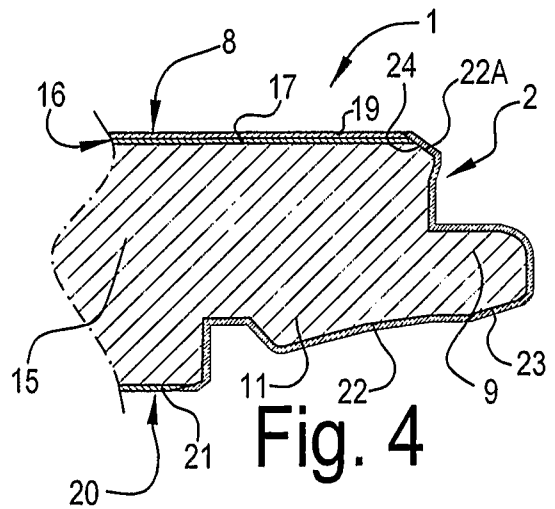
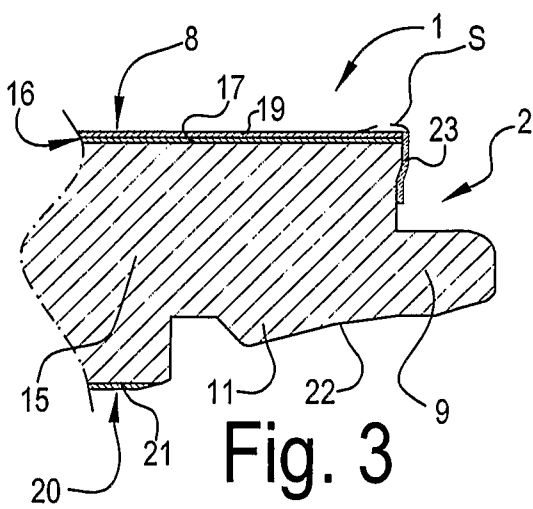
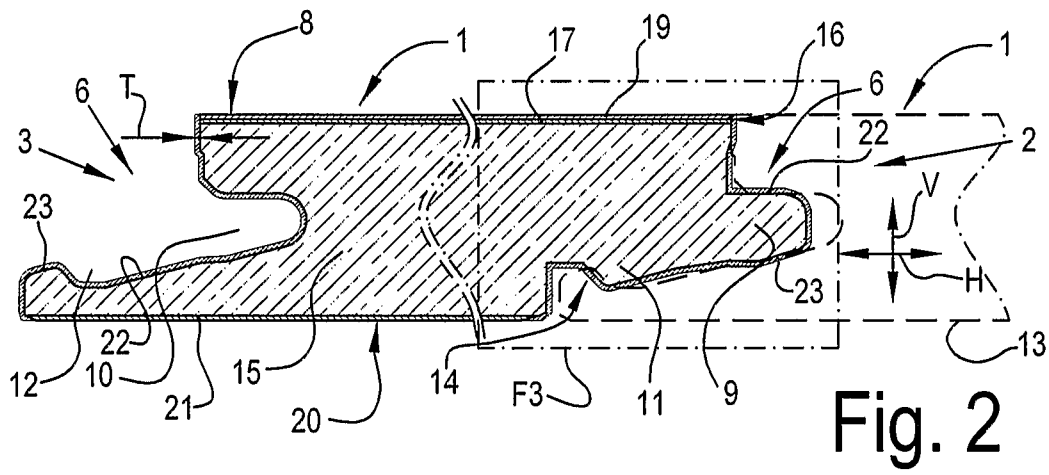
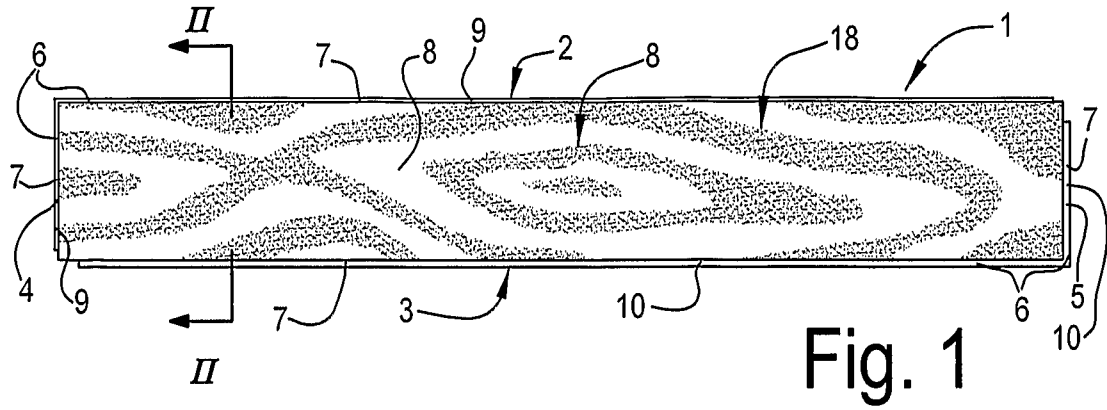

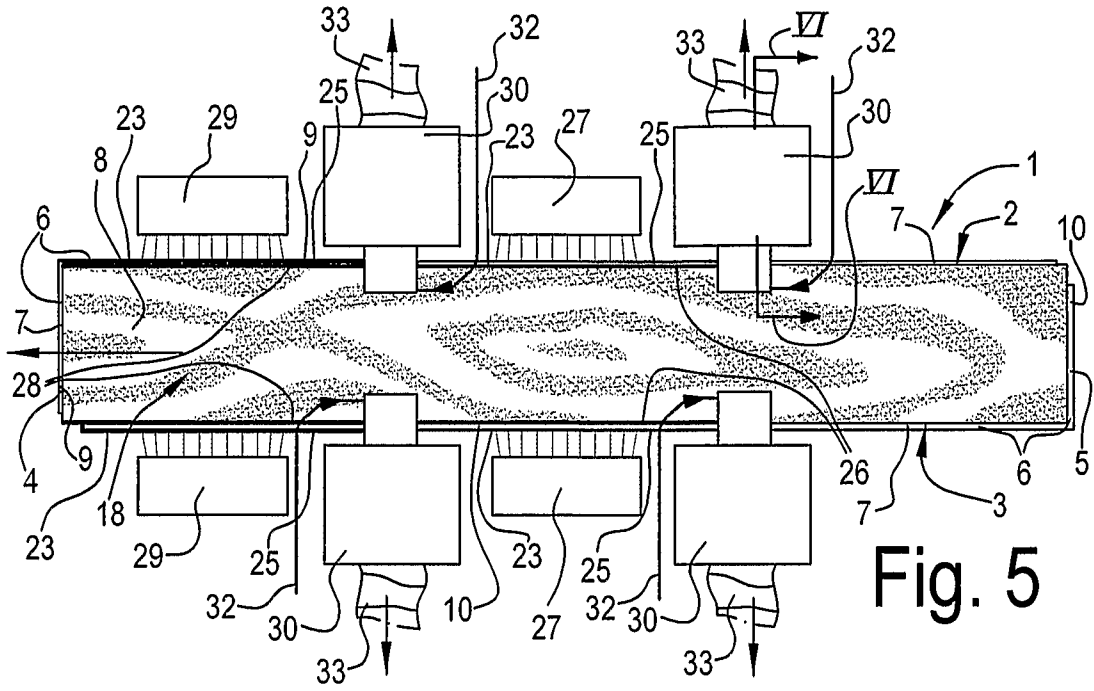

Fig. 5

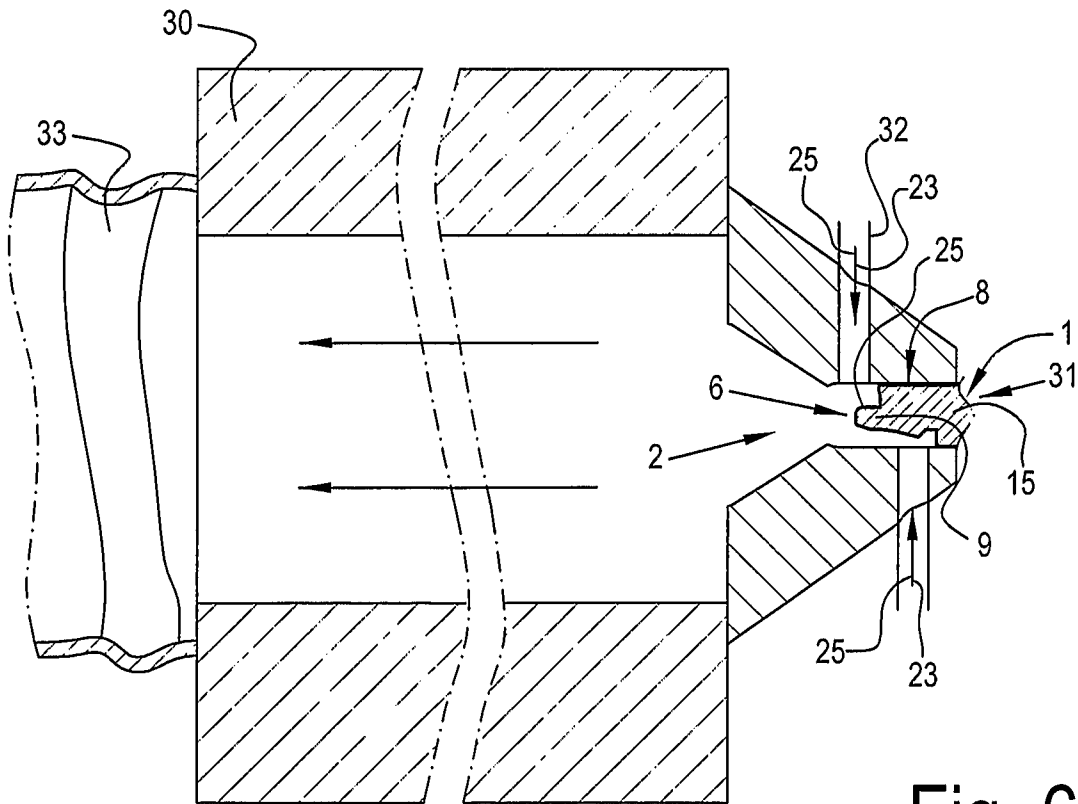

Fig. 6

**INTERNATIONAL SEARCH REPORT**

International application No  
PCT/IB2007/004149

**A. CLASSIFICATION OF SUBJECT MATTER**  
INV. C09D5/00 C09D127/12 E04F15/02 F16B5/00 E04F15/04

According to International Patent Classification (IPC) or to both national classification and IPC

**B. FIELDS SEARCHED**

Minimum documentation searched (classification system followed by classification symbols)  
C09D E04F F16B

Documentation searched other than minimum documentation to the extent that such documents are included in the fields searched

Electronic data base consulted during the international search (name of data base and, where practical, search terms used)

EPO-Internal, WPI Data

**C. DOCUMENTS CONSIDERED TO BE RELEVANT**

Category*	Citation of document, with indication, where appropriate, of the relevant passages	Relevant to claim No.
X	WO 2004/016422 A (SHAW IND GROUP INC [US]) 26 February 2004 (2004-02-26) cited in the application page 1, line 20 - line 26 page 2, line 13 - line 16 page 9, line 7 - line 13 page 10, line 12 - line 13 page 12, line 17 - page 13, line 21 page 14, line 15 - line 17	1-6, 8-13, 15
A	page 16, line 6- - line 29 claims 14,18,19; figures 2,3	7, 14, 16-26
X	DE 102 56 501 A1 (KRONOTEC AG LUZERN [CH]) 15 July 2004 (2004-07-15) paragraph [0005] paragraph [0010]	9, 14, 15, 17-20 16, 25, 26
A		

Further documents are listed in the continuation of Box C.

See patent family annex.

\* Special categories of cited documents:

- \*A\* document defining the general state of the art which is not considered to be of particular relevance
- \*E\* earlier document but published on or after the international filing date
- \*L\* document which may throw doubts on priority claim(s) or which is cited to establish the publication date of another citation or other special reason (as specified)
- \*O\* document referring to an oral disclosure, use, exhibition or other means
- \*P\* document published prior to the international filing date but later than the priority date claimed

- \*T\* later document published after the international filing date or priority date and not in conflict with the application but cited to understand the principle or theory underlying the invention
- \*X\* document of particular relevance; the claimed invention cannot be considered novel or cannot be considered to involve an inventive step when the document is taken alone
- \*Y\* document of particular relevance; the claimed invention cannot be considered to involve an inventive step when the document is combined with one or more other such documents, such combination being obvious to a person skilled in the art.
- \*G\* document member of the same patent family

Date of the actual completion of the international search

18 April 2008

Date of mailing of the international search report

06/05/2008

Name and mailing address of the ISA/

European Patent Office, P.B. 5818 Patentlaan 2  
NL - 2280 HV Rijswijk  
Tel. (+31-70) 340-2040, Tx. 31 651 epo nl,  
Fax: (+31-70) 340-3016

Authorized officer

Matthijssen, J-J

## INTERNATIONAL SEARCH REPORT

International application No

PCT/IB2007/004149

C(Continuation). DOCUMENTS CONSIDERED TO BE RELEVANT		
Category*	Citation of document, with indication, where appropriate, of the relevant passages	Relevant to claim No.
X	US 2005/016107 A1 (ROSENTHAL GUY [US] ET AL) 27 January 2005 (2005-01-27)	9, 21-23
A	paragraph [0010] - paragraph [0013]	1-8, 10-22
A	paragraph [0024] paragraph [0028] - paragraph [0029] paragraph [0044]	24
X	EP 1 229 182 A (FRITZ EGGER GMBH & CO [AT]) 7 August 2002 (2002-08-07) paragraph [0020] - paragraph [0022] paragraph [0040] claims 1,3,5,6,17-23,27,28	21-23, 25,26
X	DE 20 2005 000887 U1 (KRONOSPAN TECH CO LTD [CY]) 29 June 2006 (2006-06-29) paragraphs [0019], [0028] claims 1-4	21-24
A	US 2003/026954 A1 (WINTEROWD JACK G [US]) 6 February 2003 (2003-02-06) paragraph [0015] claim 1	1
P,X	WO 2007/113676 A (FLOORING IND LTD [IE]; SEGAERT MARTIN [BE]) 11 October 2007 (2007-10-11) page 14, line 26 - page 15, line 4 page 32, line 8 - line 24 figures 6,14 claims 1,8,9,15-18,23	1,4-6,8, 21-23

# INTERNATIONAL SEARCH REPORT

Information on patent family members

International application No

PCT/IB2007/004149

Patent document cited in search report	Publication date	Patent family member(s)	Publication date
WO 2004016422 A	26-02-2004	CN 1684824 A US 2004031225 A1	19-10-2005 19-02-2004
DE 10256501 A1	15-07-2004	NONE	
US 2005016107 A1	27-01-2005	CA 2471548 A1 MX PA04007056 A	25-01-2005 19-04-2005
EP 1229182 A	07-08-2002	AT 239156 T DE 50100214 D1	15-05-2003 05-06-2003
DE 202005000887 U1	29-06-2006	CA 2595231 A1 EP 1841932 A1 WO 2006076994 A1	27-07-2006 10-10-2007 27-07-2006
US 2003026954 A1	06-02-2003	NONE	
WO 2007113676 A	11-10-2007	BE 1017049 A6	04-12-2007