

(19) World Intellectual Property
Organization
International Bureau



(43) International Publication Date
23 September 2004 (23.09.2004)

PCT

(10) International Publication Number
WO 2004/081939 A1

(51) International Patent Classification⁷: **G11B 20/12**

(74) Agent: **LEE, Young-Pil**; The Cheonghwa Building,
1571-18, Seocho-dong, Seocho-gu, Seoul 137-874 (KR).

(21) International Application Number:
PCT/KR2004/000526

(81) Designated States (*unless otherwise indicated, for every kind of national protection available*): AE, AG, AL, AM, AT, AU, AZ, BA, BB, BG, BR, BW, BY, BZ, CA, CH, CN, CO, CR, CU, CZ, DE, DK, DM, DZ, EC, EE, EG, ES, FI, GB, GD, GE, GH, GM, HR, HU, ID, IL, IN, IS, JP, KE, KG, KP, KZ, LC, LK, LR, LS, LT, LU, LV, MA, MD, MG, MK, MN, MW, MX, MZ, NA, NI, NO, NZ, OM, PG, PH, PL, PT, RO, RU, SC, SD, SE, SG, SK, SL, SY, TJ, TM, TN, TR, TT, TZ, UA, UG, UZ, VC, VN, YU, ZA, ZM, ZW.

(22) International Filing Date: 12 March 2004 (12.03.2004)

(25) Filing Language: English

(26) Publication Language: English

(30) Priority Data:
10-2003-0015859 13 March 2003 (13.03.2003) KR
10-2003-0019963 31 March 2003 (31.03.2003) KR
10-2003-0069719 7 October 2003 (07.10.2003) KR
60/511,100 15 October 2003 (15.10.2003) US
10-2004-0006977 3 February 2004 (03.02.2004) KR

(84) Designated States (*unless otherwise indicated, for every kind of regional protection available*): ARIPO (BW, GH, GM, KE, LS, MW, MZ, SD, SL, SZ, TZ, UG, ZM, ZW), Eurasian (AM, AZ, BY, KG, KZ, MD, RU, TJ, TM), European (AT, BE, BG, CH, CY, CZ, DE, DK, EE, ES, FI, FR, GB, GR, HU, IE, IT, LU, MC, NL, PL, PT, RO, SE, SI, SK, TR), OAPI (BF, BJ, CF, CG, CI, CM, GA, GN, GQ, GW, ML, MR, NE, SN, TD, TG).

(71) Applicant: **SAMSUNG ELECTRONICS CO. LTD.**
[KR/KR]; 416, Maetan-dong, Yeongtong-gu, Suwon-si,
Gyeonggi-do 442-742 (KR).

Published:
— with international search report
— before the expiration of the time limit for amending the claims and to be republished in the event of receipt of amendments

(72) Inventors: **JUNG, Kil-Soo**; 104-1401 Namsuwon Doosan Apt., 485, Byungjeom-ri, Taean-eup, Hwaseong-gun, Gyeonggi-do 445-970 (KR). **MOON, Seong-Jin**; 436-502 Cheongmyung Maeul 4-danji Apt., 1046-1, Yeongtong 1-dong, Yeongtong-gu, Suwon-si, Gyeonggi-do 443-738 (KR).

For two-letter codes and other abbreviations, refer to the "Guidance Notes on Codes and Abbreviations" appearing at the beginning of each regular issue of the PCT Gazette.

(54) Title: INFORMATION STORAGE MEDIUM STORING A PLURALITY OF TITLES, REPRODUCING APPARATUS AND METHOD THEREOF

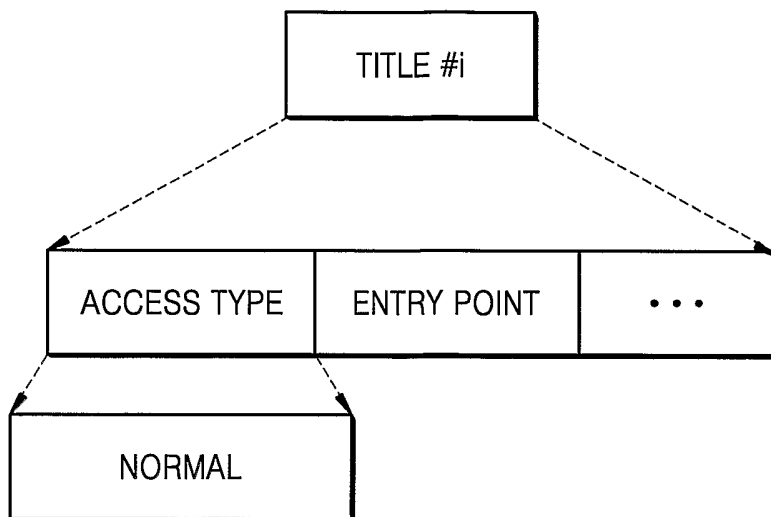

(57) Abstract: An information storage medium on which a plurality of titles are recorded, and a reproducing apparatus and method thereof. The information storage medium includes a plurality of titles which are reproduced as motion pictures and a plurality of units of attribute information that correspond to the titles and indicate whether a user can control a title to be reproduced. Therefore, efficient navigation can be ensured and the titles can be reproduced as a manufacturer of the information storage medium has planned.

WO 2004/081939 A1

INFORMATION STORAGE MEDIUM STORING A PLURALITY OF TITLES, REPRODUCING APPARATUS AND METHOD THEREOF

Technical Field

The present invention relates to reproduction of audio/video (AV) data, and more particularly, to an information storage medium on which AV data and data providing a navigation function such as a search function are recorded, and an apparatus and method of reproducing the data.

Background Art

Video titles are composed of AV data which is recorded on a Digital Video Disc (DVD)-Video disc. Additionally, navigation data which enables a user to select superimposed dialogues or search for scenes is also recorded on the DVD-Video disc reproducing the video titles.

However, there is a demand for more interaction with users and more efficient reproduction of the AV data.

Disclosure of the Invention

The present invention provides an information storage medium with a data structure in which audio/video (AV) data can be efficiently reproduced and a navigation function can be efficiently performed, and a reproducing apparatus and method of reproducing titles as motion pictures.

The present invention further provides an information storage medium with a data structure through which various applications can be provided, and a reproducing apparatus and method of providing the various applications.

According to an aspect of the present invention, there is provided an information storage medium including: a plurality of titles which are reproduced as motion pictures;

and a plurality of units of attribute information, which correspond to the titles and indicate whether a user can control a title to be reproduced.

The titles may be recorded with core mode data which includes audio/video data and navigation data reproducing the audio/video data.

Each of the titles may include at least one navigation object, and the at least one navigation object may include a navigation command which provides a command to a playlist corresponding to the title.

The title may include core mode data, which includes audio/video data and navigation data reproducing the audio/video data; and full mode data, which includes program data that enables interaction with a user and browsing data that enables Internet browsing, or the title may include a navigation object, and at least one of a browsing object that enables web browsing and a program object that enables interaction with a user.

Additional aspects and/or advantages of the invention will be set forth in part in the description which follows and, in part, will be obvious from the description, or may be learned by practice of the invention.

According to another aspect of the invention, there is provided an information storage medium including: a plurality of titles which are reproduced as moving pictures; and title access type information which corresponds to the titles and indicates whether a corresponding title can be searched for by a user operation.

The title access type information may further include title number display type information indicating whether a title number of the corresponding title is displayed.

According to another aspect of the present invention, a reproducing apparatus includes a reader, which reads a plurality of titles to be reproduced as motion pictures and a plurality of units of title information that correspond to the titles; a buffer, which buffers the data read by the reader; and a decoder, which interprets the title information

to indicate an entry point of a title and reproduces the title, wherein the decoder interprets attribute information contained in the title information to indicate whether a user can control the title to be reproduced.

The decoder may reproduce the titles, which are recorded with core mode data that includes audio/video data and navigation data reproducing the audio/video data, execute at least one navigation object that is indicated by the entry point of the title, or execute a navigation object that includes a navigation command that provides a command to reproduce a playlist corresponding to the title.

The decoder may reproduce the title which includes: core mode data, which includes audio/video data and navigation data reproducing the audio/video data; and full mode data, which includes program data that enables interaction with a user and browsing data that enables Internet browsing, execute at least one of a navigation object corresponding to the title, a browsing object that enables web browsing, and a program object that enables interaction with a user, or execute the navigation object implemented as a command program which provides a command to reproduce the playlist, the browsing object implemented as a file, which is recorded with a markup language and an executing script language, and the program object implemented as a specific program file.

The decoder may determine that the title can be searched for by the user operation if access type information as the attribute information represents the title as "normal title", and the title cannot be searched for by the user operation if the access type information represents the title as "hidden title". If the access type information represents the title as "hidden title", the decoder may display a title number of the title when the title is reproduced according to information which is contained in the attribute information that indicates whether the title number of the title is displayed.

According to still another aspect of the present invention, there is provided a reproducing method including: reading a plurality of titles that are reproduced as motion pictures and a plurality of units of title information that correspond to the titles; and

interpreting attribute information included in the title information that indicates whether a user operation can search for a corresponding title, interpreting the title information to indicate an entry point of the title, and reproducing the title.

The information interpreting and title reproducing may include reproducing the titles that are recorded with core mode data that includes audio/video data and navigation data for reproducing the audio/video data, executing at least one navigation object that is indicated by the entry point of the title, or executing a navigation object that includes a navigation command that provides a command to reproduce a playlist corresponding to the title.

The information interpreting and title reproducing may include reproducing the title which includes: core mode data, which contains audio/video data and navigation data for reproducing the audio/video data; and full mode data, which contains program data that enables interaction with a user and browsing data that enables Internet browsing, executing at least one of a navigation object corresponding to the title, a browsing object that enables web browsing, and a program object that enables interaction with a user, or executing the navigation object implemented as a command program which provides a command to reproduce the playlist, the browsing object implemented as a file, which is recorded with a markup language and an executing script language, and the program object implemented as a specific program file.

The information interpreting and title reproducing may include determining that the title can be searched for by the user operation if access type information as the attribute information represents the title as "normal title", and the title cannot be searched for by the user operation if the access type information represents the title as "hidden title". If the access type information represents the title as "hidden title", the information interpreting and title reproducing step may include displaying a title number of the title when the title is reproduced according to information which is contained in the attribute information that indicates whether the title number of the title is displayed.

Brief Description of the Drawings

These and/or other aspects and advantages of the invention will become apparent and more readily appreciated from the following description of the embodiments, taken in conjunction with the accompanying drawings of which:

FIGS. 1A, 1B, and 1C are diagrams illustrating various kinds of data recorded on a disc 100 according to an embodiment of the present invention.

FIG. 2A is a diagram illustrating the relationship between reproduction modes of the disc 100 of FIG. 1A or 1B.

FIG. 2B is a diagram illustrating the relationship among reproduction modes of the disc 100 of FIG. 1C.

FIG. 3A is a block diagram of a reproducing apparatus which supports both a core mode and a full mode according to an embodiment of the present invention.

FIG. 3B is a detailed block diagram of the reproducing apparatus of FIG. 3A.

FIG. 4A is a diagram explaining a method of reproducing core mode data recorded on the disc 100 of FIG. 1A or 1B.

FIG. 4B is a diagram explaining a method of reproducing core mode data and full mode data recorded on the disc 100 of FIG. 1C.

FIG. 5A is a diagram illustrating a data structure of a title #i which is unit information of title information according to the present invention.

FIG. 5B is a diagram illustrating a data structure of a hidden title #i which is unit information of the title information according to the present invention.

Best mode for carrying out the Invention

Reference will now be made in detail to the embodiments of the present invention, examples of which are illustrated in the accompanying drawings, wherein like reference numerals refer to the like elements throughout. The embodiments are described below to explain the present invention by referring to the figures.

FIGS. 1A, 1B, and 1C are diagrams illustrating various kinds of data recorded on a disc 100 according to an embodiment of the present invention. Data having the same function are given the same reference numerals. However, although the data are given

the same reference numerals, the data may be different from one another with respect to the contents and structure.

Referring to FIG. 1A, core mode data 1 and index information 2 are stored on the disc 100. The core mode data 1 comprises audio/video (AV) data that includes a plurality of titles and navigation data which has a plurality of navigation commands navigating the AV data, similar to a conventional digital video disc (DVD)-Video disc. The structure of the core mode data meets the requirements of the DVD-Video standards.

The index information 2 is system data, which enables a user to search for the core mode data 1 or reproduce the core mode data 1. The index information 2 designates reproduction paths of the plurality of titles that are recorded in the core mode data 1 according to a disc manufacturer's intentions. More particularly, the index information 2 comprises start up information and title information. The start up information indicates the initial AV data of a title that is to be reproduced when the disc 100 is inserted into a reproducing apparatus. The title information indicates the initial AV data of the plurality of titles to be reproduced and attribute information, which are referred to when reproducing the plurality of titles stored in the disc 100. The attribute information indicates whether a user can directly control a title to be reproduced. If the user cannot directly control the title to be reproduced, the attribute information may further contain information which indicates whether a title number of the title is displayed.

A mode in which the start up information contained in the index information 2 is reproduced is referred to as a start up mode. A mode in which the core mode data 1 is reproduced is referred to as a core mode or movie mode and the core mode is performed in the same manner as in the conventional DVD-Video disc.

Referring to FIG. 1B, core mode data 1 and index information 2 are stored on the disc 100, similarly to FIG. 1A. However, the index information 2 shown in FIG. 1B comprises start up information, title information, and menu information.

The core mode data 1 comprises AV data that includes a plurality of titles and navigation data which has a plurality of navigation commands navigating the AV data, similar to the conventional DVD-Video disc.

The start up information has the entry point that indicates the initial AV data of a title that is to be reproduced when the disc 100 is inserted into a reproducing apparatus. The title information has the entry point that indicates the initial AV data of the plurality of titles to be reproduced and attribute information, which are referred to when reproducing the plurality of titles stored in the disc 100. The attribute information indicates whether a user can directly control a title to be reproduced. If the user cannot directly control the title to be reproduced, the attribute information further contains information which indicates whether a title number of the title is displayed. This information is referred to as title number display type information.

The menu information displays a list of titles that can be selected and reproduced by the user among the plurality of titles that are recorded with the AV data, such that the user can select one of the titles.

Referring to FIG. 1C, core mode data 1, index information 2, and full mode data 3 are stored on the disc 100. The full mode data 3 comprises program data that enables interaction with the user, and browsing data that enables Internet browsing. Java applications that provide various functions for interaction with users can be included in the program data. The browsing data includes a markup document that is recorded with a markup language such as Extensible Markup Language (XML), a markup document that includes or links a script code such as a European Computer Manufacturers' Association (ECMA) script code, a script file, and a resource file including at least one image, graphic, and sound referred to by a markup document.

The full mode data 3 and the core mode data 1 can communicate with each other using an Application Program Interface (API).

The titles include several different mode data. In other words, the titles include at least part of the AV data which is included in the core mode data 1 and the browsing data and the program data which are included in the full mode data 3. For example, while a movie is being displayed, a quiz relating to a scene can be displayed, or an Internet page giving the latest information about actors and actresses appearing in the scene can be displayed.

The index information 2 is system data, which enables the user to more conveniently search for or reproduce the core mode data 1 and the full mode data 3. The index information 2 designates reproduction paths of the plurality of titles that are comprised of the core mode data 1 and the full mode data 3 according to the disc manufacturer's intentions. More particularly, the index information 2 comprises start up information, title information, and menu information, similarly to the index information described with reference to FIG. 1B. The title information indicates the initial AV data of the plurality of titles to be reproduced and attribute information, which is referred to when reproducing the plurality of titles stored in the disc 100. The attribute information indicates whether the user can directly control a title to be reproduced. If the user cannot directly control the title to be reproduced, the attribute information may further contain information which indicates whether a title number of the title is displayed.

Similar to the modes described with reference to FIGS. 1A and 1B, a mode in which the start up information and the menu information are reproduced is referred to as a start up mode, a mode in which the core mode data is reproduced is referred to as a core mode, a mode in which program data is reproduced is referred to as a program mode, and a mode in which the browsing data is reproduced is referred to as a browsing mode.

When the disc 100 is reproduced, the reproducing apparatus first reads the start up information and searches for data indicated by the start up information to reproduce the data. If the start up information provides instructions to reproduce the core mode data, the reproducing apparatus is set to the core mode, if the start up information

provides instructions to reproduce the program data, the reproducing apparatus is set to the program mode, and if the start up information provides instructions to reproduce the browsing data, the reproducing apparatus is set to the browsing mode.

For example, the AV data shown in FIGS. 1A, 1B, and 1C is recorded as an AV stream file that is encoded using a Motion Picture Experts Group (MPEG)-II encoding method. A continuous AV stream file is called a clip stream file. A clip information file corresponds to each clip stream file. Reproduction control information regarding the clip stream file, for example, mapping information which maps a reproduction time and a recording position, is stored in the clip information file. The clip information file that corresponds to the clip stream file is referred to as a clip.

A playlist indicates at least a part of one of the clips. In other words, the playlist is a unit of reproduction, and corresponds to one clip, a part of one of the clips, a plurality of the clips, or parts of a plurality of the clips. The playlist can be reproduced via the API as an object in the browsing mode and the program mode. A playlist is a unit of reproduction described from a player's point of view while a title is a unit of reproduction described from the user's point of view. That is, a title corresponds to at least one playlist.

The navigation data is typically stored in the form of a binary code table. In an embodiment of the present invention, the navigation data includes a plurality of commands including commands reproducing a predetermined playlist and commands reproducing another playlist during the reproduction of the predetermined playlist.

FIG. 2A is a diagram illustrating the relationship between reproduction modes of the disc of FIG. 1A or 1B. Referring to FIG. 2A, after the disc 100 of FIG. 1A or 1B is loaded into the reproducing apparatus, the reproducing apparatus reads the start up information and determines the location from which the initial AV data of a title is to be reproduced so as to initiate the reproduction of the title. For example, the start up information can be implemented using a navigation command that provides instructions

to reproduce a specific playlist that should be reproduced. After the start up mode is completed, the mode is changed into core mode.

FIG. 2B is a diagram illustrating the relationship among reproduction modes of the disc 100 of FIG. 1C. Referring to FIG. 2B, after the disc 100 of FIG. 1C is loaded into the reproducing apparatus, the reproducing apparatus reads the start up information and determines the location of the initial AV data of a title which is to be reproduced so as to initiate the reproduction of the title. For example, the start up information can be implemented using a navigation command which gives instructions to reproduce a specific playlist that should be reproduced. After the start up mode is completed, the mode is changed into the core mode.

Because some reproducing apparatuses can reproduce only the core mode data, both core start up information and full start up information must be included in the start up mode. If the core start up information does not exist, a reproducing apparatus that can reproduce only the core mode data cannot operate. Particularly, when a disc in which the start up information only provides instructions to reproduce the full mode data, it is impossible to initiate reproduction. For this reason, both the core start up information and the full start up information are provided in the start up mode, so that the reproducing apparatus that can reproduce only the core mode data can initiate reproduction using the core start up information.

If the start up information contains commands to initially reproduce core mode data 1, the start up mode is converted into the core mode. If the start up information contains commands to initially reproduce the full mode data, the start up mode is converted into the full mode.

FIG. 3A is a block diagram of a reproducing apparatus which supports both the core mode and the full mode according to an embodiment of the present invention.

Referring to FIG. 3A, the reproducing apparatus reproduces the AV data in the core mode or the full mode by using the core mode data 1 and/or the full mode data 3

stored in the disc 100. The reproducing apparatus includes a reader 10, a buffer 20, and a decoder 30.

The reader 10 reads the necessary data from the disc 100. The buffer 20 buffers the data read by the reader 10. The decoder 30 decodes and outputs the data buffered by the buffer 20.

FIG. 3B is a detailed block diagram of the reproducing apparatus of FIG. 3A.

Referring to FIG. 3B, the buffer 20 includes a browsing data buffer 21 which buffers the browsing data, a program data buffer 22 which buffers the program data, a navigation data buffer 23 which buffers the navigation data, an AV data buffer which buffers the AV data, and an index information buffer 25 which buffers the index information.

The decoder 30 includes a browsing engine 31 which interprets the browsing data and executes browsing commands, a program engine 32 which interprets the program data and executes program commands, a navigation engine 33 which interprets the navigation data and executes navigation commands, and a presentation engine 34 which decodes the AV data. These engines can transmit information to one another via the API.

In particular, the decoder 30 includes an application manager 35 which interprets the index information. The application manager 35 selects and reproduces a title which is to be first reproduced according to an entry point indicated by the start up information contained in the index information, and informs the engine corresponding to the entry point according to mode conversion during the reproduction. Further, the application manager 35 receives a user's input and transmits the input to the engine that corresponds to the user's input mode.

FIG. 4A is a diagram explaining a method of reproducing the core mode data stored in the disc 100 of FIG. 1A or 1B.

Referring to FIG. 4A, the title information comprises a plurality of units of information, each of which designates a navigation object. The unit information is implemented as a title #i or a hidden title #j. The title #i can be reproduced in response to a user. The hidden title #j cannot be reproduced by the user. That is, the hidden title #j is reproduced only in the order predetermined by a manufacturer of the disc 100. In other words, allowing reproduction control allows the titles to be searched for by a user initiated operation.

When a specific title is selected through a title search in the disc 100 of FIG. 1A or the menu information is reproduced and one of the titles shown in the menu is selected from the disc 100 of FIG. 1B, the title information indicates an entry point where data is to be initially executed or reproduced, that is, a navigation object. The navigation object is implemented as an executable navigation command program. In other words, the navigation object is an upper layer of the playlist that is a unit of reproduction, and includes the navigation command that initiates the reproduction of the specific playlist.

For example, if the user selects a first title #1, the first title #1 includes title information that designates a first navigation object #1, thereby executing the first navigation object #1. The first navigation object #1 includes a navigation command. When the navigation command is executed, a predetermined playlist is reproduced. After the playlist is reproduced according to the first navigation object #1, the first navigation object #1 indicates a first hidden title #1, and a third navigation object #3 designated by the first hidden title #1 is executed. Here, a hidden title is not directly selected by the user to be reproduced. The hidden title is only reproduced in the order predetermined by the disc manufacturer. For example, a moving picture including an official announcement about a copyright, a moving picture of a trailer broadcasted after a movie ends, etc. can be a hidden title. Because these moving pictures are searched by the user operation and need little be reproduced separately, these moving pictures are set to hidden titles and are reproduced only in the order determined by the navigation command.

If the user selects a second title #2, the second title #2 designates a second navigation object #2, thereby executing the second navigation object #2. The second navigation object #2 also includes a navigation command for reproducing a predetermined playlist. The predetermined playlist is reproduced when the navigation command is executed. After the playlist is reproduced according to the second navigation object #2, the second navigation object #2 indicates a second hidden title #2, and a fifth navigation object #5 designated by the second hidden title #2 is executed.

FIG. 4B is a diagram explaining a method of reproducing the core mode data and the full mode data stored in the disc 100 of FIG. 1C.

Referring to FIG. 4B, the index information includes the start up information, the menu information, and the title information. The title information comprises a plurality of units of information each of which designates a navigation object. The unit information is implemented as a title #i or a hidden title #j. The title #i can be controlled by the user to be reproduced and the hidden title #j cannot be controlled by the user to be reproduced. That is, the hidden title #j is reproduced only in the order predetermined by the manufacturer of the disc.

When the disc 100 is loaded into the reproducing apparatus, a plurality of navigation objects are reproduced according to the start up information. If the user calls a menu, the menu information is reproduced. If the user selects one of the titles shown in the menu, the title information indicates an entry point where data is to be initially executed or reproduced, that is, an object.

In an embodiment of the present invention, the object is divided into a navigation object corresponding to the core mode data, a browsing object corresponding to the browsing data, and a program object corresponding to the program data. The navigation object is implemented as a command program that provides a command to reproduce the core mode data, and the browsing object is implemented as a file that is recorded with the browsing data, for example, with a markup language and an

executing script language, and has a file name as an entry point. The program object is implemented as a specific program file which has a file name as an entry point.

One object belonging to a predetermined mode can be connected to another object belonging to another mode so as to be reproduced. When objects belonging to the same mode are connected to one another, mode conversion is not required. However, mode conversion is required when objects belonging to different modes are connected to one another. The mode conversion is carried out using the hidden title information contained in the title information. That is, the title information indicates an entry point for title search and an entry point for reproduction of a predetermined title, and the hidden title information indicates an entry point for mode conversion among the core mode, the browsing mode, and the program mode.

After the disc 100 of FIG. 1C is loaded, the reader 10 of the reproducing apparatus reads the index information 2 and transmits the read index information 2 to the application manager 35. The application manager 35 provides instructions from the start up information to indicate a title which is to be initially reproduced. Alternatively, if the user calls a menu and selects a title among the titles shown in the menu, the application manager refers to an entry point of the selected title and transmits an object designated by the selected title to the engine corresponding to the selected title. According to an embodiment of the present invention, because the initial title to be reproduced as instructed by the start up information is a navigation object, in operation 1, an entry point of the navigation object is transmitted to the navigation engine 33. The navigation engine 33 commences the reproduction of the core mode data by transmitting a navigation command contained in the navigation object to the presentation engine 34. In operation 2, another navigation object designated by a first title #1 is reproduced after the navigation object is first executed in the core mode. The navigation object reproduced in operation 2 may be reproduced in operation 3 through a title search. In the same manner, second and third titles #2 and #3 are respectively connected to the browsing object and the program object in operation 4 and 5, and the titles can be reproduced when the user provides a command to reproduce them.

In operation 6, the navigation object designated by the first title #1 is connected to the browsing object via a first hidden title #1. In other words, the mode conversion is performed with reference to the first hidden title #1. In this case, the navigation engine 33 transfers control to the application manager 35. The application manager 35 provides instructions to the browsing engine 31 to reproduce the browsing object designated by the first hidden title #1. In this way, the hidden title cannot be directly accessed by the user. Because a title can include data in a variety of modes through the mode conversion with reference to the hidden title, the user can reproduce the title without regard to the mode conversion.

FIG. 5A is a diagram illustrating a data structure of a title #i according to an embodiment of the present invention.

Referring to FIG. 5A, the title #i includes access type information that acts as attribute information. The title #i also indicates an entry point of a title. The access type information indicates whether the user can directly control the title to be reproduced. Since the title #i permits the user's direct access, the access type information represents the title #i as "normal title".

FIG. 5B is a diagram illustrating a data structure of a hidden title #i according to an embodiment of the present invention.

Referring to FIG. 5B, the hidden title #j also includes access type information that acts as attribute information, and indicates an entry point of a title. The access type information indicates whether the user can directly control the title to be reproduced. Because the hidden title #j prohibits the user's direct access, the access type information represents the title #ji as "hidden". The access type information further contains information that indicates whether a title number of the "hidden" title is displayed to the user. That is, the access type information displays the title number when the title number is allotted to the hidden title and does not display the title number when the title number is not allotted to the hidden title.

For example, assuming that the access type information is represented in a binary form, if the value of 1 bit of the access type information is "1", the title is a hidden title that is used only as a bridge point for mode conversion, while if the value of the access type information is "0", the title is a normal title that can also be used as an access point for title search.

Table 1 shows a case where only title access type information of 1 bit is included in the attribute information and Table 2 shows a case where title access type information and title display information are included in the attribute information, respectively. Here, the attribute information may be index table information.

Table 1

Title access type	Result
0	Title search is allowable by a user
1	Title search is not allowable by a user

Table 2

Title access type	Result
00	Title search is allowable by a user and a title number is displayed
01	Title search is allowable by a user and a title number is not displayed
10	Title search is not allowable by a user and a title number is

	displayed
11	Title search is not allowable by a user and a title number is not displayed

Referring to Table 2, a first bit of the title access type indicates whether a corresponding title can be searched for directly by a user operation or whether the corresponding title can be searched for only by a navigation command. A second bit of the title access type indicates whether the title number is displayed to a user.

The present invention may be embodied in a general purpose digital computer by running a program from a computer usable medium, including but not limited to storage media such as magnetic storage media (e.g., ROMs, RAMs, floppy discs, hard discs, etc.), optically readable media (e.g., CD-ROMs, DVDs, etc.) and carrier waves (e.g., transmissions over the Internet). The computer readable recording medium can be dispersively installed in a computer system connected to a network, and stored and executed as a computer readable code in a distributed computing environment.

As described above, because attribute information indicates whether a plurality of titles are hidden titles or not, a disc manufacturer can produce contents with which various applications can be made. That is, because the titles are divided into titles that can be accessed directly and titles that can only be accessed in a predetermined order determined by the manufacturer of the disc, contents suitable for the disc manufacturer's intentions can be produced. Accordingly, various applications can be provided to users.

Although a few embodiments of the present invention have been shown and described, it would be appreciated by those skilled in the art that changes may be made in this embodiment without departing from the principles and spirit of the invention, the scope of which is defined in the claims and their equivalents.

What is claimed is:

1. An information storage medium, comprising:
a plurality of titles which are reproduced as motion pictures; and
a plurality of units of attribute information, which correspond to the titles and indicate whether a user is able to control one of the titles to be reproduced.
2. The information storage medium of claim 1, further comprising title information which indicates entry points of the plurality of titles corresponding to the attribute information.
3. The information storage medium of claim 1, wherein the titles are recorded with core mode data which includes audio/video data and navigation data reproducing the audio/video data.
4. The information storage medium of claim 1, wherein each of the titles includes at least one navigation object.
5. The information storage medium of claim 4, wherein the at least one navigation object includes a navigation command which provides a command to reproduce a playlist corresponding to the title.
6. The information storage medium of claim 5, wherein the playlist indicates at least a part of a clip.
7. The information storage medium of claim 6, wherein the playlist is a unit of reproduction, and corresponds to one clip, a part of one clip, a plurality of clips, or parts of a plurality of clips.
8. The information storage medium of claim 1, wherein the titles comprise:

core mode data which includes audio/video data and navigation data reproducing the audio/video data; and

full mode data which includes program data that enables interaction with a user and browsing data that enables Internet browsing.

9. The information storage medium of claim 1, wherein the title includes a navigation object, and at least one of a browsing object that enables web browsing and a program object that enables interaction with a user.

10. The information storage medium of claim 9, wherein the navigation object is implemented as a command program which provides a command to reproduce a predetermined playlist, the browsing object is implemented as a file which is recorded with a markup language and an executing script language, and the program object is implemented as a specific program file.

11. The information storage medium of claim 9, wherein the playlist is reproducible using the browsing object and the program object.

12. The information storage medium of claim 1, wherein the attribute information includes access type information which represents each title as "normal title" if the title is searchable by a user operation and represents each title as "hidden title" if the title is not searchable by the user operation.

13. The information storage medium of claim 12, wherein the access type information that represents the title as "hidden title" further contains information that indicates whether a title number of the title is displayed.

14. A reproducing apparatus, comprising:

a reader which reads data comprising a plurality of titles to be reproduced as motion pictures and a plurality of units of title information that correspond to the titles from an information storage medium;

a buffer which buffers the data read by the reader; and

a decoder which interprets the title information to indicate an entry point of the title and reproduces the title,

wherein the decoder interprets attribute information contained in the title information to indicate whether a user is able control the title to be reproduced.

15. The reproducing apparatus of claim 14, wherein the decoder reproduces the titles, which are recorded with core mode data including audio/video data and navigation data reproducing the audio/video data.

16. The reproducing apparatus of claim 14, wherein the reader reads start up information, and the decoder searches the start up information for one title that is to be first reproduced.

17. The reproducing apparatus of claim 14, wherein the decoder executes at least one navigation object that is indicated by the entry point of the title.

18. The reproducing apparatus of claim 14, wherein the decoder executes a navigation object that includes a navigation command that provides a command to reproduce a playlist corresponding to the title.

19. The reproducing apparatus of claim 14, wherein the decoder reproduces a playlist that indicates at least a part of a clip.

20. The reproducing apparatus of claim 14, wherein the decoder reproduces a playlist that is a unit of reproduction which corresponds to one clip, a part of one clip, a plurality of clips, or parts of a plurality of clips.

21. The reproducing apparatus of claim 14, wherein the decoder reproduces the title which comprises:

core mode data, which includes audio/video data and navigation data reproducing the audio/video data; and

full mode data, which includes program data that enables interaction with a user and browsing data that enables Internet browsing.

22. The reproducing apparatus of claim 21, wherein the decoder executes at least one of a navigation object corresponding to the title, a browsing object that enables web browsing, and a program object that enables interaction with a user.

23. The reproducing apparatus of claim 22, wherein the decoder executes the navigation object implemented as a command program which provides a command to reproduce a playlist, the browsing object implemented as a file, which is recorded with a markup language and an executing script language, and the program object implemented as a specific program file.

24. The reproducing apparatus of claim 22, wherein the decoder reproduces a predetermined playlist by executing the browsing object and the program object.

25. The reproducing apparatus of claim 21, wherein the decoder determines that the title is searchable by a user operation if access type information which acts as the attribute information represents the title as "normal title", and the title is not searchable by the user operation if the access type information represents the title as "hidden title".

26. The reproducing apparatus of claim 25, wherein if the access type information represents the title as "hidden title", the decoder displays a title number of the title when the title is reproduced according to information which is contained in the attribute information that indicates whether the title number of the title is displayed.

27. A reproducing method, comprising:
reading a plurality of titles that are reproduced as motion pictures and a plurality of units of title information that correspond to the titles; and
interpreting attribute information included in the title information that indicates whether a user operation is able to search for a corresponding one of the titles, interpreting the title information to indicate an entry point of the title, and reproducing the title.

28. The reproducing method of claim 27, wherein the interpreting the attribute information includes reproducing the titles that are recorded with core mode data that includes audio/video data and navigation data reproducing the audio/video data.

29. The reproducing method of claim 27, wherein the reading plurality of titles includes reading start up information, and the interpreting the attribute information includes interpreting the start up information and searching for one of the titles in the start up information that is to be first reproduced.

30. The reproducing method of claim 27, wherein the interpreting the attribute information includes executing at least one navigation object that is indicated by the entry point of the title.

31. The reproducing method of claim 27, wherein the interpreting the attribute information includes executing a navigation object that includes a navigation command that provides a command to reproduce a playlist corresponding to the title.

32. The reproducing method of claim 27, wherein the interpreting attribute information includes reproducing a playlist that indicates at least a part of a clip.

33. The reproducing method of claim 27, wherein the interpreting the attribute information includes reproducing a playlist that is a unit of reproduction and corresponds to one clip, a part of one clip, a plurality of clips, or parts of a plurality of clips.

34. The reproducing method of claim 27, wherein the interpreting the attribute information includes reproducing the title which comprises: core mode data, which contains audio/video data and navigation data for reproducing the audio/video data; and full mode data which contains program data that enables interaction with a user and browsing data that enables Internet browsing.

35. The reproducing method of claim 34, wherein the interpreting the attribute information includes executing at least one of a navigation object corresponding to the title, a browsing object that enables web browsing, and a program object that enables interaction with a user.

36. The reproducing method of claim 35, wherein the interpreting the attribute information includes executing the navigation object implemented as a command program which provides a command to reproduce a playlist, the browsing object implemented as a file, which is recorded with a markup language and an executing script language, and the program object implemented as a specific program file.

37. The reproducing method of claim 35, wherein the interpreting the attribute information includes reproducing a predetermined playlist by executing the browsing object and the program object.

38. The reproducing method of claim 36, wherein the interpreting the attribute information includes determining that the title is searchable by a user operation if access type information included in the attribute information represents the title as "normal title", and the title is not searchable by the user operation if the access type information represents the title as "hidden title".

39. The reproducing method of claim 38, displaying a title number of the title when the title is reproduced according to information which is contained in the attribute information that indicates whether the title number of the title is displayed if the access type information represents the title as the "hidden title".

40. An information storage medium, comprising:
a plurality of titles which are reproduced as motion pictures; and
title access type information, which corresponds to the titles and indicates whether the corresponding titles is able to be searched for by a user operation.

41. The information storage medium of claim 40, wherein the title access type information further comprises title number display type information which indicates whether a title number of the corresponding title is displayed.

42. An information storage medium, comprising:
core mode data which comprises audio and/or video (AV) data; and
index information designating reproduction paths of the AV data recorded in the core mode data, wherein the core mode data is searchable by a user communicating with the index information.

43. The information storage medium of claim 42, wherein the index information comprises:
start up information designating an entry point of the AV data of an initial title to be reproduced upon initiating a reproduction of the information storage medium; and

title information designating the AV data corresponding to respective titles to be reproduced and attribute information designating whether each title is controllable by a user.

44. The information storage medium of claim 43, wherein the attribute information comprises title number display type information to reproduce a title number when a corresponding one of the titles is not controllable by the user.

45. The information storage medium of claim 44, wherein the index information further comprises:

menu information displaying a list of the titles that are selectable and reproducible by the user from among the titles based on the attribute information.

46. The information storage medium of claim 45, further comprising:
full mode data comprising at least one of program data enabling interaction with the user and browsing data enabling Internet browsing, and
wherein the index information designates reproduction paths of the titles comprising core mode data and full mode data.

47. The information storage medium of claim 46, wherein the program data comprises Java applications.

48. The information storage medium of claim 46, wherein the browsing data comprises a markup document.

49. The information storage medium of claim 46, wherein the core mode data and the full mode data communicate by an application program interface (API).

50. The information storage medium of claim 46, wherein the titles comprise a part of the AV data in the core mode data, and at least one of the program data and browsing data in the full mode data.

51. The information storage medium of claim 50, wherein the startup information comprises both core mode data startup information and full mode data startup information, wherein the information storage medium is compatible with a reproducing apparatus which only reproduces core mode data.

52. A reproducing apparatus using an information storage medium, comprising:

a reader which reads titles and title information corresponding to the respective titles from the information storage medium;

a buffer which buffers the titles and title information; and

a decoder which selectively decodes the titles based on the title information and attribute information in the title information designating user control of the selected decoded titles.

53. The apparatus of claim 52, wherein the attribute information further comprises number display information indicating whether a title number of one of the selected decoded titles is to be reproduced.

54. The apparatus of claim 52, wherein the decoder interprets startup information from the title information and decodes one of the titles corresponding to the startup information first.

55. The apparatus of claim 54, wherein each title comprises at least one of, core mode data which comprises audio and/or video (AV) data and navigation commands corresponding to the AV data; and

full mode data which comprises at least one of program data enabling interaction with the user and browsing data enabling Internet browsing.

56. The apparatus of claim 55, wherein the decoder comprises:
a browsing engine decoding the browsing data and executing browsing commands from the decoded browsing data;
a program engine decoding the program data and executing program commands from the decoded program data;
a navigation engine decoding navigation commands in the titles and the title information;
a presentation engine decoding the AV data; and
an application manager controlling reproduction of the titles based on whether a portion of each title is startup information, core mode data, or full mode data and user input when the attribute information designates that the respective title is controllable by the user.

57. The apparatus of claim 56, wherein the application manager controls a mode conversion corresponding to a core mode reproducing the core mode data and a full mode reproducing the full mode data when each title is decoded.

58. The apparatus of claim 57, wherein the mode conversion is executed by hidden title information in the title information which the user is unable to control.

59. The apparatus of claim 58, wherein the hidden title information is decoded in a predetermined order set by a manufacturer of the information storage medium.

FIG. 1A

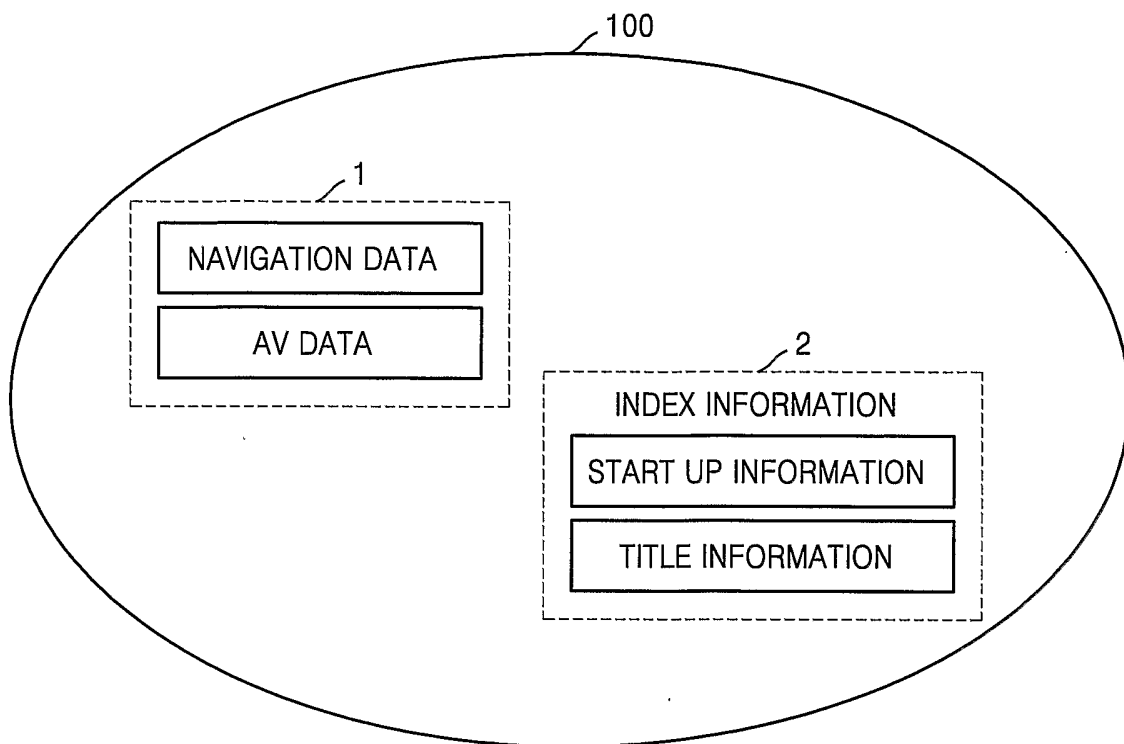
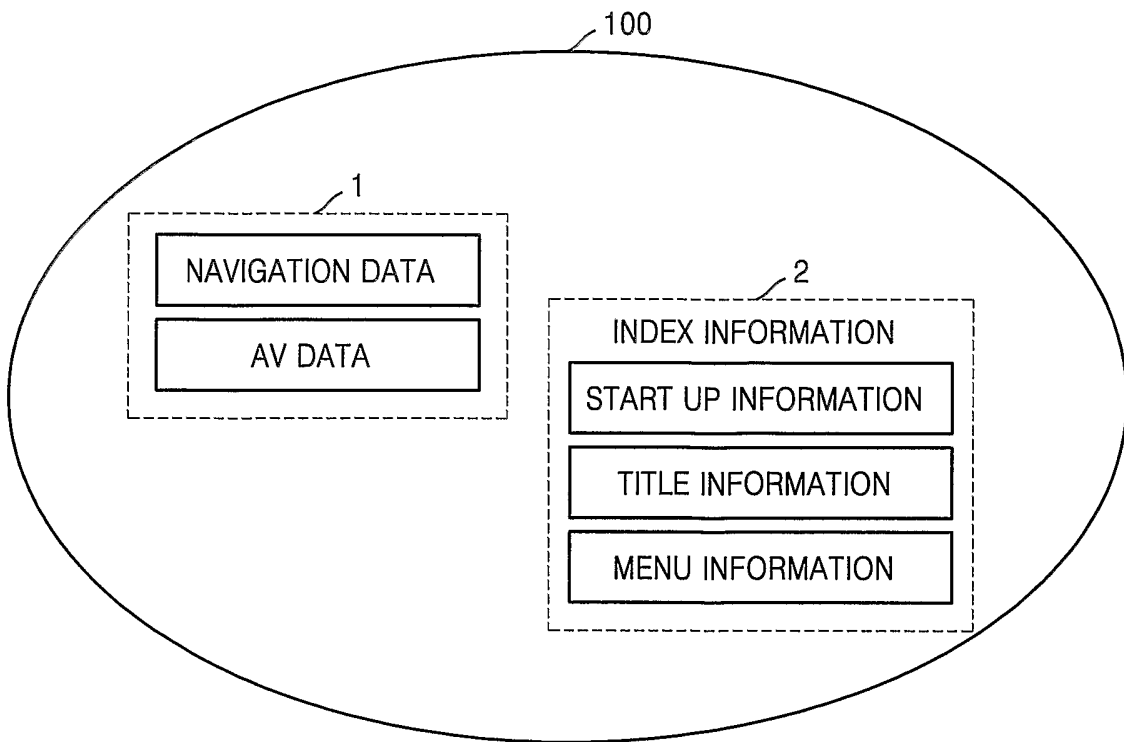

FIG. 1B



2/7

FIG. 1C

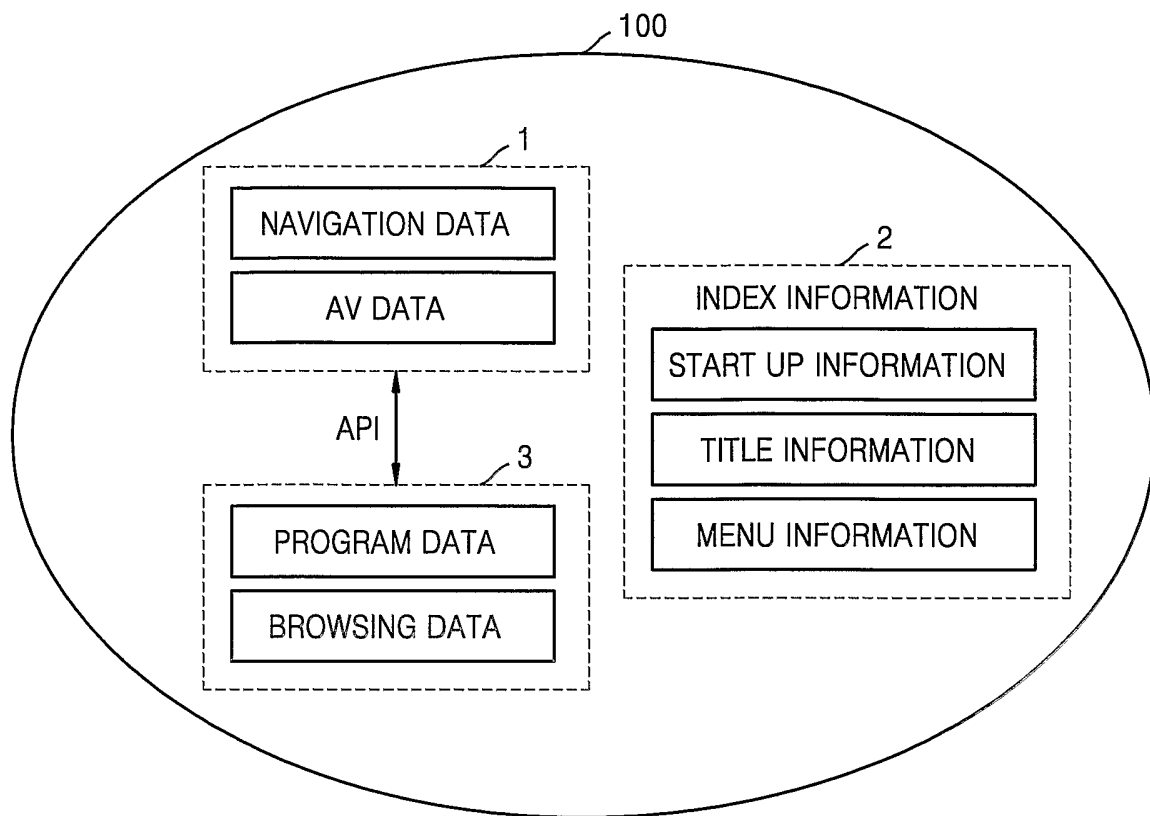
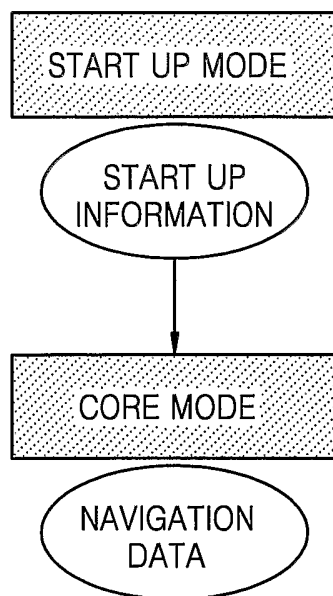

FIG. 2A



3/7

FIG. 2B

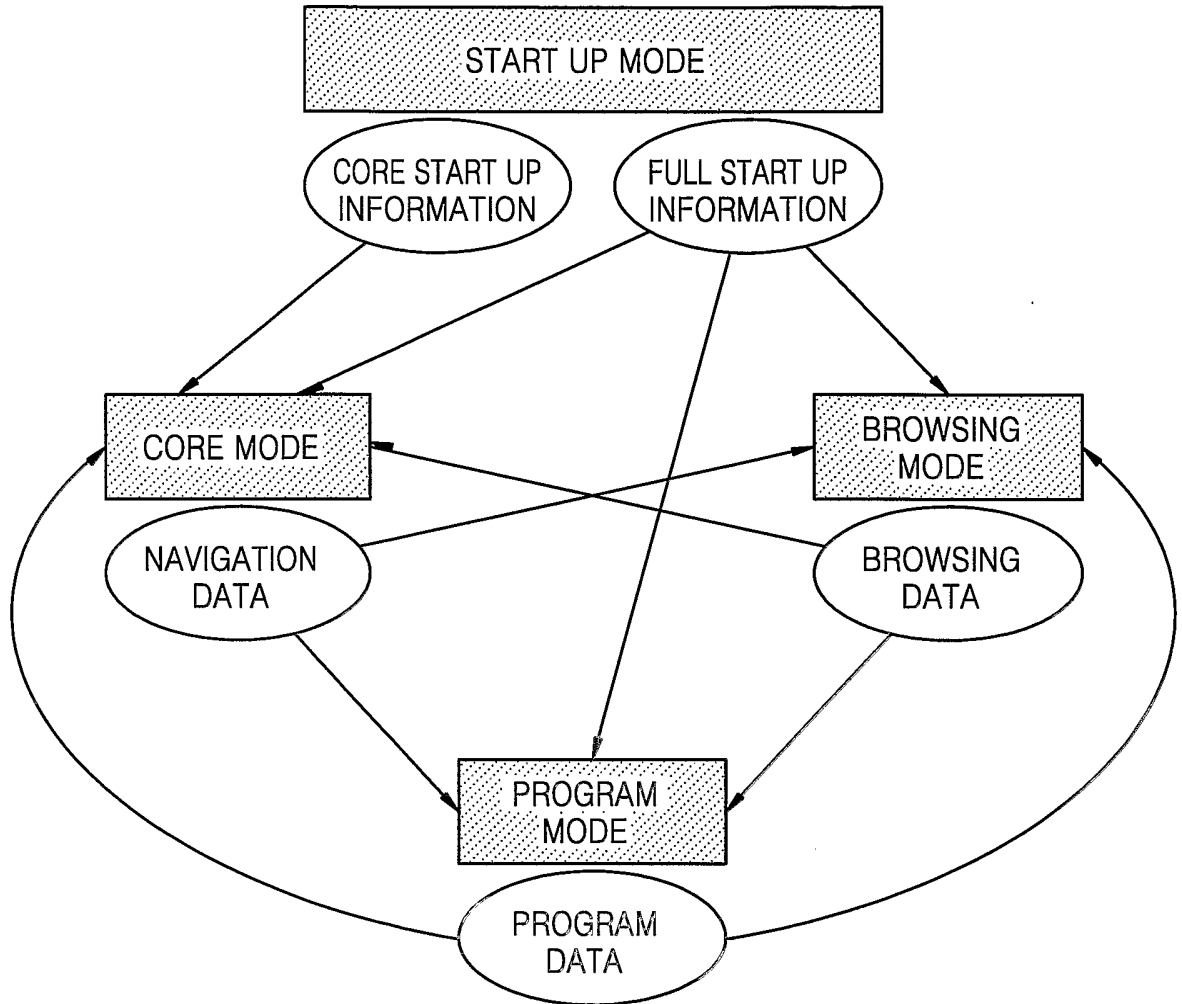

FIG. 3A

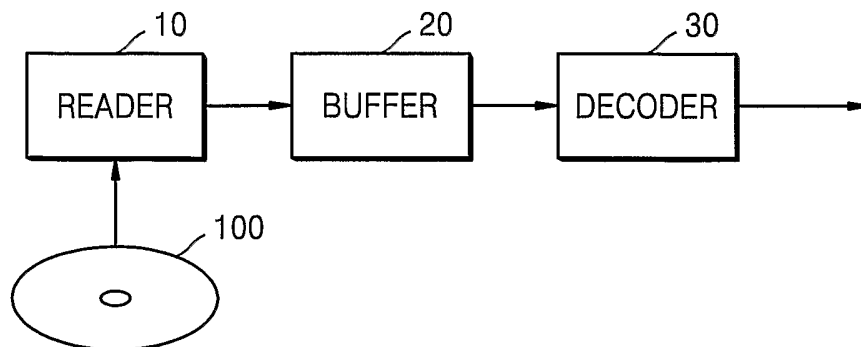
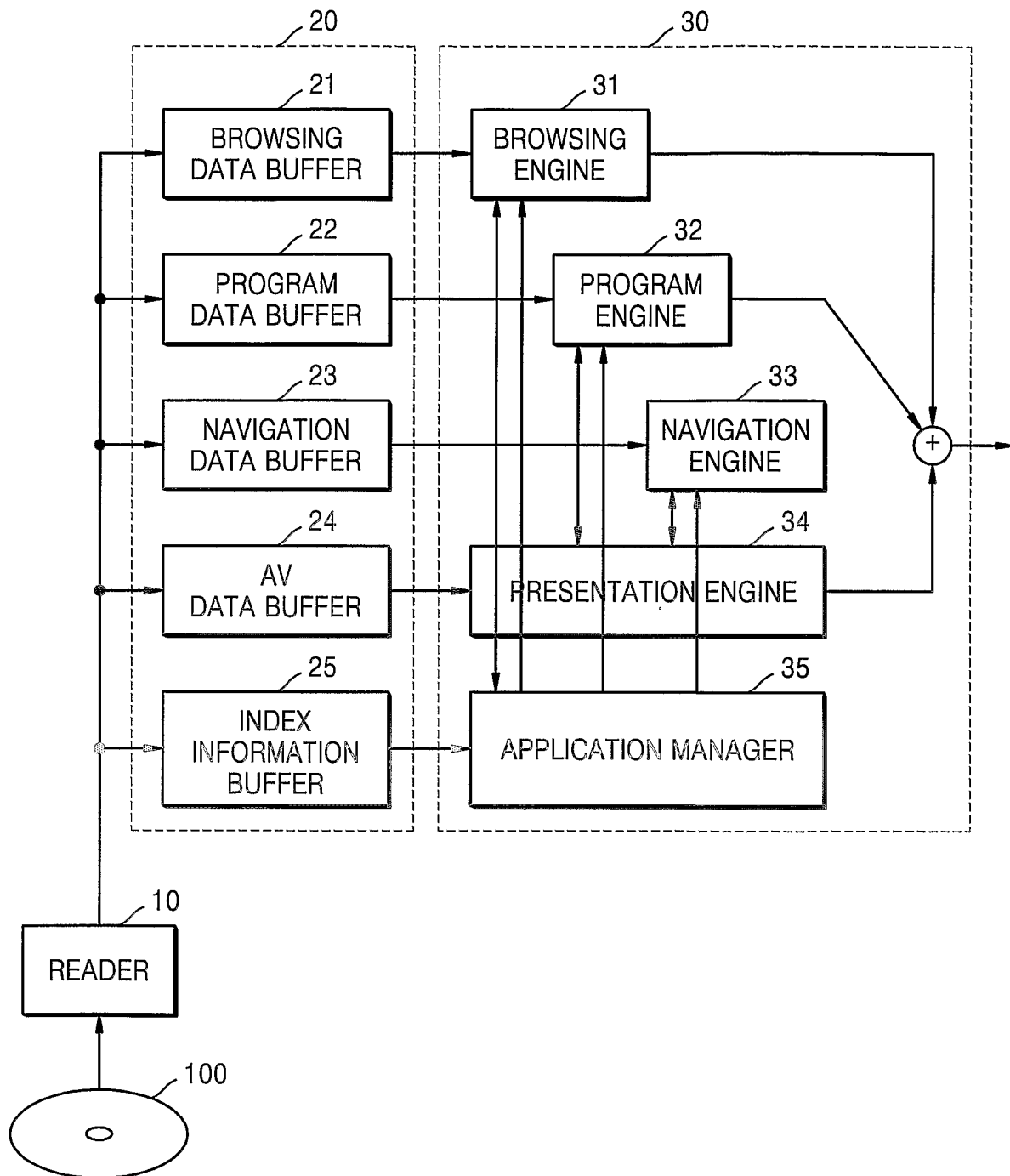

FIG. 3B



5/7
FIG. 4A

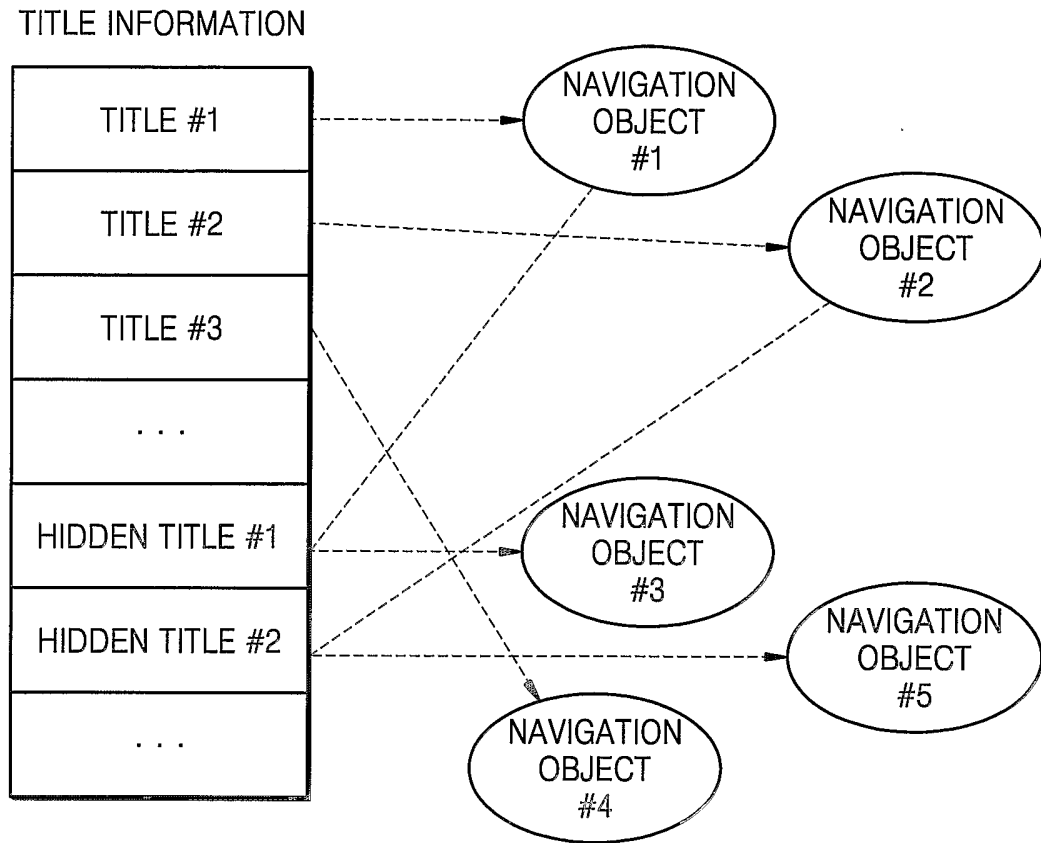
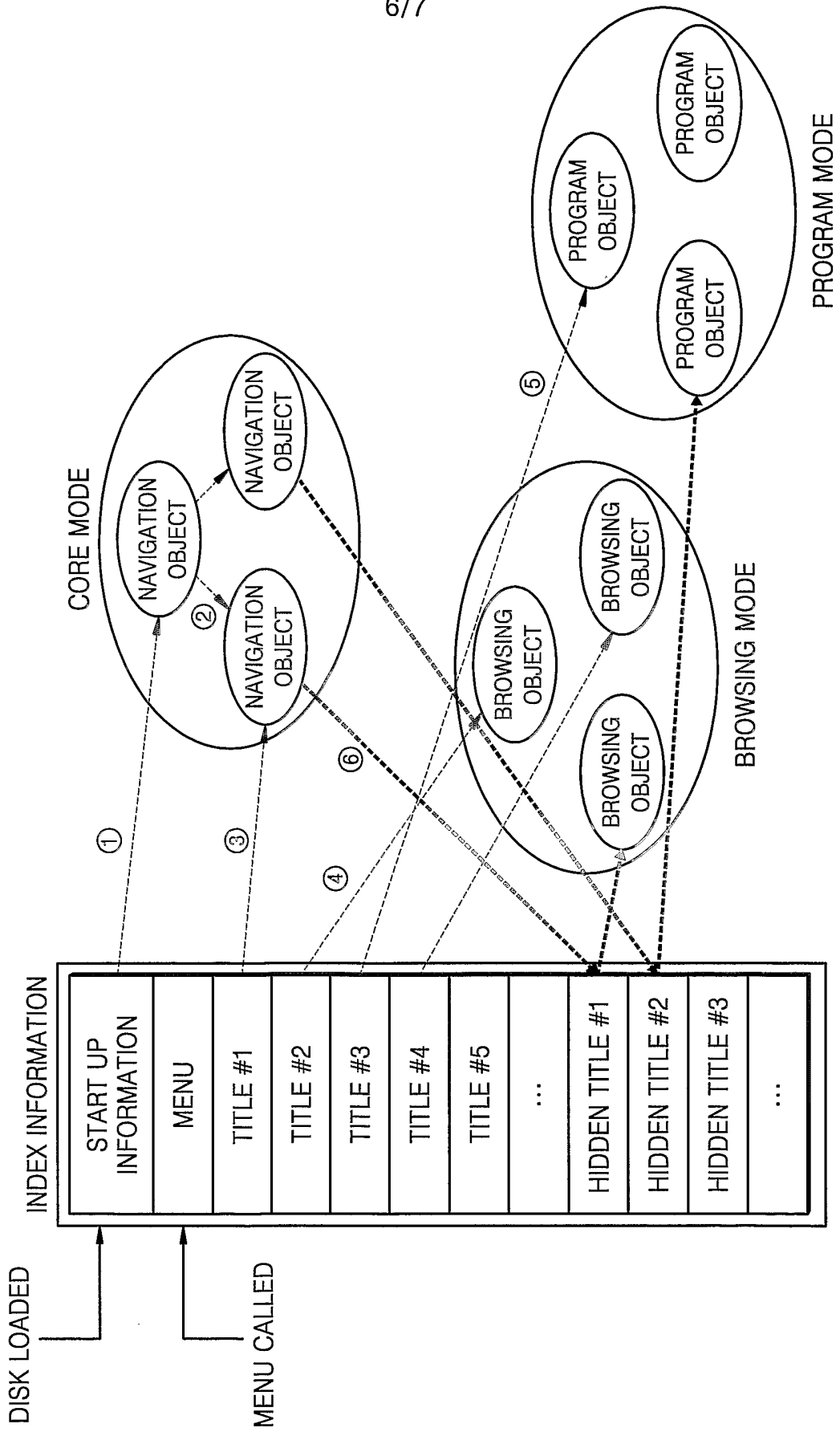

FIG. 4B



7/7

FIG. 5A

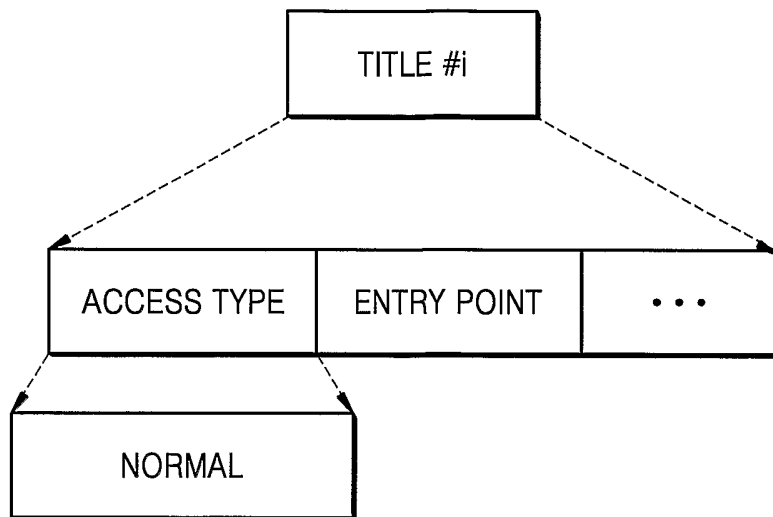
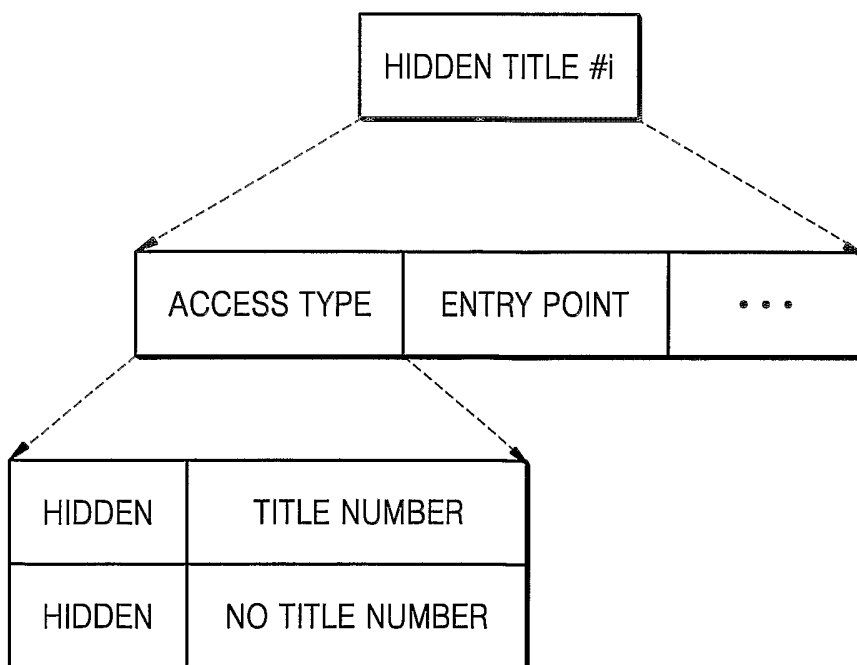

FIG. 5B



INTERNATIONAL SEARCH REPORT

International application No.
PCT/KR2004/000526

A. CLASSIFICATION OF SUBJECT MATTER

IPC7 G11B 20/12

According to International Patent Classification (IPC) or to both national classification and IPC

B. FIELDS SEARCHED

Minimum documentation searched (classification system followed by classification symbols)

G11B 20/12 G11B 20/10 H04N 5/92 G11B 27/00

Documentation searched other than minimum documentation to the extent that such documents are included in the fields searched

Electronic data base consulted during the international search (name of data base and, where practicable, search terms used)

WPI, PAJ "title, attribute, access, video/audio, entry point, navigation, clip, playlist"

C. DOCUMENTS CONSIDERED TO BE RELEVANT

Category*	Citation of document, with indication, where appropriate, of the relevant passages	Relevant to claim No.
Y	EP 0,737,009 A2 (KABUSHIKI KAISHA TOSHIBA) 09 Oct. 1996 See the whole document	1-7, 14-20, 27-33, 40-42, 52-53
A	EP 0,737,979 A2 (KABUSHIKI KAISHA TOSHIBA) 16 Oct. 1996 See the whole document	1, 14, 27, 40, 42, 52
A	EP 0,872,839 A2 (KABUSHIKI KAISHA TOSHIBA) 21 Oct. 1998 See the whole document	1, 14, 27, 40, 42, 52
A	WO 02-069339 A1 (SONY CORPORATION) 06 Sep. 2002 See the whole document	1, 14, 27, 40, 42, 52
P,A	WO 2004-001752 A1 (LG ELECTRONICS INC.) 31 Dec. 2003 See the whole document	1, 14, 27, 40, 42, 52

Further documents are listed in the continuation of Box C.

See patent family annex.

* Special categories of cited documents:

"A" document defining the general state of the art which is not considered to be of particular relevance

"E" earlier application or patent but published on or after the international filing date

"L" document which may throw doubts on priority claim(s) or which is cited to establish the publication date of citation or other special reason (as specified)

"O" document referring to an oral disclosure, use, exhibition or other means

"P" document published prior to the international filing date but later than the priority date claimed

"T" later document published after the international filing date or priority date and not in conflict with the application but cited to understand the principle or theory underlying the invention

"X" document of particular relevance; the claimed invention cannot be considered novel or cannot be considered to involve an inventive step when the document is taken alone

"Y" document of particular relevance; the claimed invention cannot be considered to involve an inventive step when the document is combined with one or more other such documents, such combination being obvious to a person skilled in the art

"&" document member of the same patent family

Date of the actual completion of the international search

22 JULY 2004 (22.07.2004)

Date of mailing of the international search report

23 JULY 2004 (23.07.2004)

Name and mailing address of the ISA/KR

 Korean Intellectual Property Office
920 Dunsan-dong, Seo-gu, Daejeon 302-701,
Republic of Korea

Facsimile No. 82-42-472-7140

Authorized officer

KIM, Yong Woong

Telephone No. 82-42-481-5698



INTERNATIONAL SEARCH REPORT

International application No. PCT/KR2004/000526
--

Patent document cited in search report	Publication date	Patent family member(s)	Publication date
EP0737009A2	09. 10. 1996	AT188589T	15. 01. 2000
		CA2173701A1	07. 10. 1996
		CN1141477A	29. 01. 1997
		DE69605963D1	10. 02. 2000
		EP0737009A2	09. 10. 1996
		KR215130B1	16. 08. 1999
EP0737979A2	16. 10. 1996	KR272410B1	01. 12. 2000
		US5949955A	07. 09. 1999
EP0872839A2	21. 10. 1998	KR220529B1	15. 09. 1999
		CA2168327C	11. 04. 2000
		AT191292E	15. 04. 2000
		CN1134583A	30. 10. 1996
		US5870523A	09. 02. 1999
		TW434531B	16. 05. 2001
WO02-069339A1	06. 09. 2002	DE69607489C0	04. 05. 2000
		None	
WO2004-001752A1	31. 12. 2003	None	