

Feb. 12, 1935.

A. C. KELLER ET AL

1,990,548

SOUND RECORDER AND REPRODUCER

Filed June 20, 1934

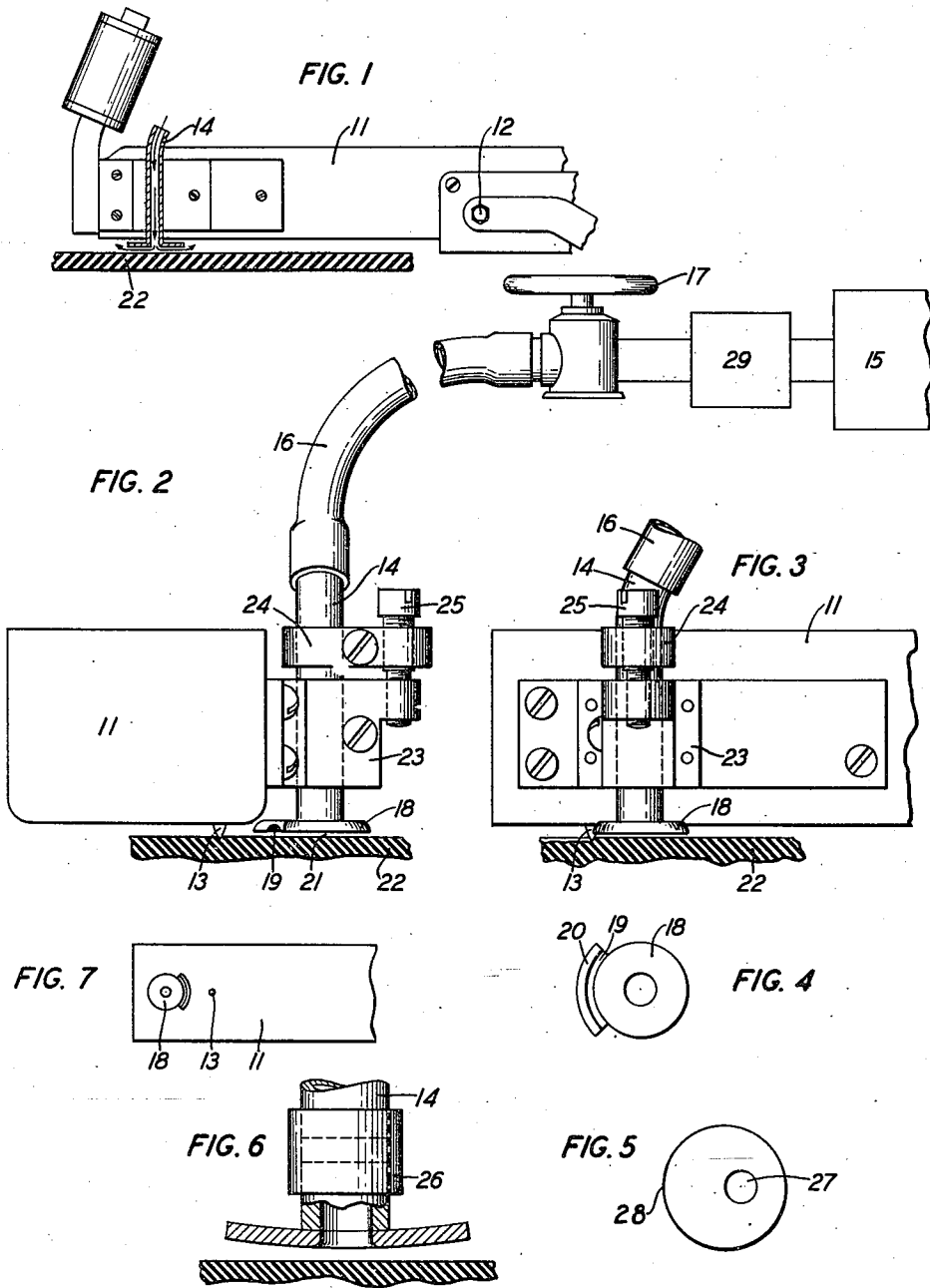

INVENTORS A. C. KELLER
I. S. RAFUSE
BY *G. M. Campbell*
ATTORNEY

UNITED STATES PATENT OFFICE

1,990,548

SOUND RECORDER AND REPRODUCER

Arthur C. Keller, Mount Vernon, and Irad S. Rafuse, Hempstead, N. Y., assignors to Bell Telephone Laboratories, Incorporated, New York, N. Y., a corporation of New York

Application June 20, 1934, Serial No. 731,428

9 Claims. (Cl. 274—1)

This invention relates to sound recording and reproducing systems and the object of the invention is an improved supporting structure for recorders and reproducers.

In making original disc recordings on soft wax, it has become common practice, particularly since the advent of electrical recorders, to use a so-called "advance ball" to regulate the depth of the groove being cut. The advance ball is usually in the form of a jewel cylinder mounted on the recorder near the stylus and having a spherically ground end which slides over the uncut portion of the wax surface.

The reproduction of phonograph records is accompanied by more or less extraneous noise. Some of this noise originates in the recording itself, some of it is added in the duplicating process, and some of it is due to the nature of the material from which the pressings are made. Considerable progress has been made toward the elimination of this noise and recent developments have so greatly reduced the noise due to other causes that the mechanical disturbances caused by the advance ball as it slides over the wax are now audible in finished records and are often predominant in original recordings.

Noise of this latter type is eliminated according to the invention by keeping the recorder in proper position with respect to the recording surface by means of a stable system of forces set up by an expanding fluid stream flowing between the recorder and the recording surface. The preferred structure comprises a tube leading from a source of compressed and preferably filtered air and terminating in a relatively large flange on the recorder adjacent the stylus and just above the recording surface. The impact of the air moving downwardly tends to raise the flange above the surface and the increasing cross-section of the air path as the air moves radially outward along the flange produces an area of less than atmospheric pressure under the flange which tends to keep the flange near the recording surface. For any given recorder structure and suitable air pressure applied to the tube, the flange, under the action of these opposing forces, takes a position slightly above the surface and supports the recorder in stable equilibrium without any mechanical contact with the moving record surface. This supporting structure does not disfigure the recording surface even when the wax used would be entirely too soft to permit the use of a conventional advance ball, and it has the further advantage that any tendency of the recorder

to bounce as when accidentally jarred is very quickly suppressed. The recorder itself may be made much heavier and more rugged than when an advance ball is used, so that the reactions of the record material on the cutting stylus do not affect the shape of the groove being cut.

The flange is usually flat but in some cases it may be in the form of a spherical segment, as explained more fully below. When the flange is mounted near the stylus, the force of the air on the vibrating stylus may produce a slight undesirable disturbance. This is prevented, according to the invention, by means of an air trap in the flange on the side nearest the stylus for reducing the flow of air at this point.

In most reproducing systems the reproducer functions satisfactorily with the unbalanced weight of the reproducer supported by the stylus, but in certain special cases, the present invention may also be used to advantage with reproducers. When used for example with a reproducer which tends to jump into an adjacent groove due to the large amplitude of groove undulations or for other reasons, the partial vacuum developed under the flange is very effective in keeping the stylus in continuous contact with the groove. When the invention is applied to playback devices for reproducing original recordings, the vibratory structure may be much more fragile than in cases where the stylus supports the unbalanced weight. This makes it possible to reduce the weight of the playback and the mechanical impedance of its moving system to such low values that even very soft records can be reproduced without injury to the grooves.

These and other features of the invention will be more fully understood from the following detail description and the accompanying drawing, in which

Fig. 1 shows a conventional electrical recorder supported in cutting position according to this invention;

Figs. 2 and 3 are enlarged views of the recorder and its air tube supporting structure;

Fig. 4 is a terminating flange with one form of air trap;

Fig. 5 is an eccentric flange for diverting the air from the stylus;

Fig. 6 is an air tube with a spherical instead of a flat flange; and

Fig. 7 is a bottom view of a translating device with the flange in front of the stylus.

Referring now to Figs. 1, 2 and 3, the trans-

lating device 11 shown for the purpose of illustrating the invention is a recorder of a type now in general use which is ordinarily partially balanced about its horizontal pivot 12 by a counterweight (not shown), the unbalanced mass being supported by an advance ball near the stylus 13. In this case the advance ball is replaced by the pneumatic system of this invention comprising the tube or air conduit 14 which is connected to the tank 15 of compressed air by the flexible tubing 16.

Since dust and moisture would impair the record surface, suitable filtering apparatus 29 is connected in the supply line and a pressure reducing control valve 17 is provided to regulate the air pressure in the tube 14. The ratio of the flange diameter to the bore of the tube is not very critical and depending on the particular structure to be supported it may vary from about 2 to 1 to something less than 10 to 1. In the structure of Figs. 2 and 3, the tube is of one eighth inch bore and terminates in a flat flange 18 about one half inch in diameter. By means of the valve 17, air is applied to the tube at five to fifteen pounds gauge pressure and the recorder may then be safely placed on the rotating record blank 22. As the flange approaches the record surface, the escaping air is deflected and moves radially outward between the opposed surfaces as indicated by the arrows in Fig. 1 and a position of equilibrium is reached with the flange about two or three mils above the wax surface 22.

Some physics text-books describe an experiment illustrating this phenomenon in which a sheet of paper is held from falling away from the bottom of a spool by blowing downwardly through the hole in the spool. Applicants' structure just described, however, supports a recorder in proper cutting position with a surprising degree of stability. A downward blow on the recorder much more severe than any disturbance likely to arise inadvertently during the making of a record produces only a momentary and almost imperceptible decrease in the spacing between the flange and the wax and the low pressure area under the flange makes it necessary to apply a force of about 100 grams to lift the recorder from the wax.

Since the recording surface cannot readily be made optically flat, it is desirable to mount the flange as near to the stylus as possible so that the flange will follow irregularities in the wax surface and thereby maintain the stylus at the proper cutting depth. For the recorder of Fig. 2, it is most convenient to mount the flanged tube on the side of the recorder as shown. While the depth of cut can be regulated to some extent at least by varying the air pressure, it is desirable to provide a mechanical adjustment for the tube 14. In the form illustrated the tube is a sliding fit in the bracket 23 and is held in vertical adjustment by the clamping member 24. The adjusting screw 25 is preferably of the compound type having an upper threaded portion engaging the member 24 and a lower portion with threads of slightly different pitch engaging the bracket 23. If, for example, the threads used are thirty-six and forty per inch, respectively, a quarter turn of the screw will change the depth of the groove cut by less than three quarters of a mil-inch and obviously by resorting to special threads any desired degree of fineness of adjustment may be obtained. In practice a recorder is usually adjusted with

great care by a skilled operator, but in some cases it may be positioned with the flange at a slight angle to the wax surface. If in such a case the tube 14 is made in two sections connected by a rubber or other flexible coupling 26 as shown in Fig. 6, a greater flow of air occurs on the side of greatest spacing producing a greater downward force in this region and the flexible coupling permits the flange to take up its proper position parallel to the wax surface. The flexible connection obviously may also be used with air conduits having flanges of the types shown in Figs. 4 and 5.

Since there is no mechanical contact with the wax, no noise of the type produced by a sliding advance ball is introduced into the record. The old type advance ball was also objectionable in that it slightly smeared the wax surface and since the ball preceded the stylus this disfiguring spiral was often quite noticeable in finished pressings at the end of the record groove. With the pneumatic tube of this invention no disfiguration occurs and the flange may either precede or follow the stylus across the record so that the recorder may be used without change to cut grooves either toward or away from the center of the record.

It has already been explained that the flange should be mounted as closely as possible to the cutting stylus but when a simple flange of the type shown in Fig. 1 is used the pressure of the escaping air on the stylus may produce a slight modulating or distorting effect on its vibrations and a corresponding characteristic noise is heard when the record is reproduced. When it is impractical to make the vibrating structure rigid enough to eliminate this effect entirely, this distortion may be prevented by stopping or diminishing the air flow in the direction of the stylus. In the preferred structure for accomplishing this result as shown in Fig. 2, the flange is provided with a segment of about ninety degrees (Fig. 4) extending beyond the circular portion and containing a deep circumferential groove 19, the outer rim 20 of the segment being coplanar with the face 21 of the flange or extending about one mil below the flange. The acoustic impedance along the groove 19 is very low compared to the impedance between the rim 20 and the wax so that most of the air moving radially toward the stylus will be deflected tangentially and the modulating effect on the stylus is substantially eliminated. Alternatively the flange itself may be eccentric with respect to the air conduit to provide a longer acoustic path and hence one of higher impedance in the direction of the stylus. One such flange is illustrated in Fig. 5 in which the air path from the end of the conduit 27 to the outer rim at 28 is two or three times as long as the path in the opposite direction. It will be understood that the configuration of such a flange may be varied considerably to obtain the effect desired in a particular case.

When the design of the recorder or reproducer permits or when it has been specifically designed with this in view, it is of some advantage to locate the flange 18 in front of the stylus 13 as shown in the bottom view of a recorder in Fig. 7. With this arrangement the translating device is equally well adapted to move across a record either from the outside in or from the inside out since the small blank space ordinarily left beyond the outer groove is of sufficient width to prevent the air from

escaping freely from the tube when the recorder or reproducer is near the periphery of the record.

In the foregoing description the several flanges discussed are flat but if desired a spherical flange with a radius of curvature of the order of six to twelve inches as shown in Fig. 6 may be used. It will also be understood that the curved flange may be provided with any suitable form of air trap for deflecting the air from the stylus.

While the invention has been described with reference to a system using compressed air to support the recorder, it will be understood that any other gas or liquids such as water may be used if desired. For example when the record blank is submerged in water during the cutting operation to prevent dust from accumulating in the groove, it may be advantageous to use water instead of air as the supporting fluid.

What is claimed is:

1. The combination with a record member and a vibration translating device cooperating therewith, of a fluid conduit on the device having a flange member in close spaced relation to the record member, and means for producing a flow of fluid between said members for maintaining the spacing between them.

2. The combination with a record member and a pivoted recording device for forming a groove in the member of means for maintaining a desired spacing between the member and the device comprising a conduit for a fluid stream on the device terminating at one end in a flange close to the surface of the record member, and a source of fluid under pressure attached to the other end of the conduit.

3. The combination with a record member and a vibration translating device cooperating therewith of means for maintaining a desired spacing between the device and the surface of the member comprising an annular surface on the device in close spaced relation to the surface of the member, and means for producing an outward radial flow of fluid between the surfaces.

4. The combination with a record member and

a vibration translating device having a stylus cooperating with the member, of a tube on said device connected to a source of fluid under pressure and terminating in a flange substantially parallel to the record member, and means for reducing the flow of fluid in the direction of the stylus.

5. The combination with a record member and a translating device having a stylus cooperating with the member, of a conduit for a fluid stream attached to the device, a flange in close spaced relation to the member near the stylus mounted on the conduit, and a protruding segment on the flange having a groove therein for deflecting the fluid away from the stylus.

6. The combination with a record member and a translating device having a stylus cooperating with the member, of a conduit for a fluid stream attached to the device, and a flange in close spaced relation to the member near the stylus eccentrically mounted on the conduit.

7. The combination with a record member and a translating device having a stylus cooperating with the member, of a conduit for a fluid stream attached to the device, a flange in close spaced relation to the member, and a flexible connection between the flange and the conduit.

8. The combination with a record blank and a recorder having a stylus for forming a groove in the blank, of a conduit for a fluid stream attached to the recorder, a flange on the conduit in close spaced relation to the blank near the stylus, means for supplying fluid under pressure to the conduit, and means for varying the spacing between the flange and the record blank.

9. The combination with a record member and a translating device having a stylus cooperating with the member, of means for maintaining the device in operative relation to the member comprising a source of fluid under pressure, a conduit for a fluid stream from said source attached to the device, and a flange on the conduit in close spaced relation to the member above the groove engaged by the stylus.

ARTHUR C. KELLER. 45
IRAD S. RAFUSE.