

(19) World Intellectual Property
Organization
International Bureau



(43) International Publication Date
23 December 2004 (23.12.2004)

PCT

(10) International Publication Number
WO 2004/111352 A1

(51) International Patent Classification⁷: **E02D 29/14**

(21) International Application Number:
PCT/NZ2004/000127

(22) International Filing Date: 18 June 2004 (18.06.2004)

(25) Filing Language: English

(26) Publication Language: English

(30) Priority Data:
526572 18 June 2003 (18.06.2003) NZ

(71) Applicant and

(72) Inventor: **RHODES, Derrick Anthony** [NZ/NZ]; 59 Francis Street, Grey Lynn, AUCKLAND (NZ).

(74) Agent: **BALDWIN SHELSTON WATERS**; PO Box 5999, Wellesley Street, AUCKLAND, 1000 (NZ).

(81) Designated States (unless otherwise indicated, for every kind of national protection available): AE, AG, AL, AM,

AT, AU, AZ, BA, BB, BG, BR, BW, BY, BZ, CA, CH, CN, CO, CR, CU, CZ, DE, DK, DM, DZ, EC, EE, EG, ES, FI, GB, GD, GE, GH, GM, HR, HU, ID, IL, IN, IS, JP, KE, KG, KP, KR, KZ, LC, LK, LR, LS, LT, LU, LV, MA, MD, MG, MK, MN, MW, MX, MZ, NA, NI, NO, NZ, OM, PG, PH, PL, PT, RO, RU, SC, SD, SE, SG, SK, SL, SY, TJ, TM, TN, TR, TT, TZ, UA, UG, US, UZ, VC, VN, YU, ZA, ZM, ZW.

(84) Designated States (unless otherwise indicated, for every kind of regional protection available): ARIPO (BW, GH, GM, KE, LS, MW, MZ, NA, SD, SL, SZ, TZ, UG, ZM, ZW), Eurasian (AM, AZ, BY, KG, KZ, MD, RU, TJ, TM), European (AT, BE, BG, CH, CY, CZ, DE, DK, EE, ES, FI, FR, GB, GR, HU, IE, IT, LU, MC, NL, PL, PT, RO, SE, SI, SK, TR), OAPI (BF, BJ, CF, CG, CI, CM, GA, GN, GQ, GW, ML, MR, NE, SN, TD, TG).

Published:

— with international search report

For two-letter codes and other abbreviations, refer to the "Guidance Notes on Codes and Abbreviations" appearing at the beginning of each regular issue of the PCT Gazette.

(54) Title: A UTILITY PORTAL

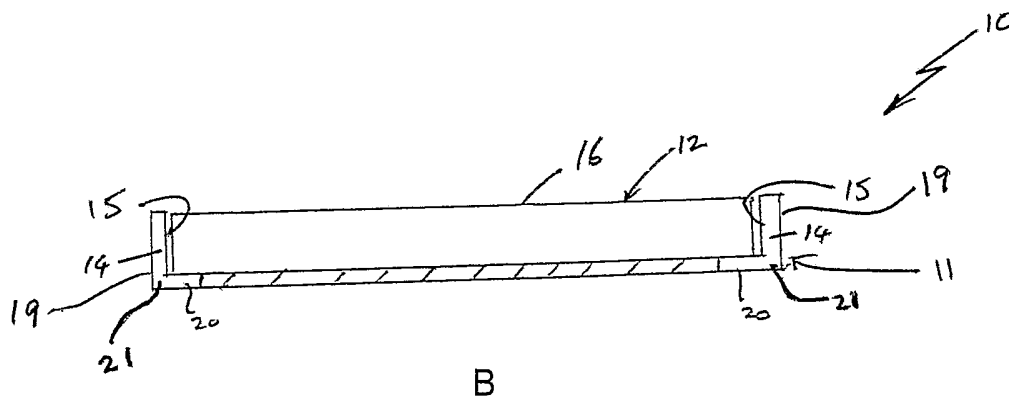

(57) Abstract: A utility portal, including - a frame including a base plate and at least one side which extends substantially orthogonally from an outer peripheral edge or edges of the base plate - a cover engageable with the frame; wherein said frame can in use be raised from a first position substantially below a new surface plane to a second position to align with the new surface plane substantially without disturbance to an existing surface adjacent to the frame.

WO 2004/111352 A1

A UTILITY PORTAL

Technical Field of the Invention

5 The invention broadly relates to roading and highway fixtures. More specifically, the invention relates to an improved road utility portal and a frame for the portal unit. The invention also provides a method of elevating the frame in a surface.

Background of the Invention

10

Road utility portals which include manhole portals, fire hydrants and water and power utility portals are a common feature of most urban roads, footpaths, motorways and highways. These utility portals provide access to power cables, water and drainage pipes which lie beneath a road surface.

15

Figures 1A and 1B illustrate a plan view of a commonly used utility portal which is generally referenced 1. The portal 1 includes a frame 2 and a cover 3. The frame 2 is substantially round or oval in shape and includes a base plate 4 and a side 5 which extends upwardly from an upper face 6 of the base plate 4. The base plate 4 provides a flange member 7a and an internal ledge member 7 separated by the upwardly extending side 5. The cover 3 rests on the ledge member 7. A plurality of side supports 8 form a wedge between the side 5 and the flange member 7a to provide additional support for the side 5.

20

25 Although Figure 1 shows the portal 1 as substantially round, a flange member 7a is common for square and rectangular portals 1. A portal 1 adapted for use with a manhole is normally engaged with a concrete top (not shown) which in turn is positioned over a manhole shaft.

30

The frame 2 is secured by concrete, bolts, screws, adhesive or the like to the concrete top of the manhole shaft. Road seal which includes concrete, tar seal and/or asphalt then covers the top of the concrete shaft and flange member 7a of the base plate 4 to secure the frame 2 in place. The concrete, tar seal and/or asphalt covers the flange member 7a and the supports 8. This further secures the frame 2 in place and

35

substantially aligns the road surface with the sides 5 and upper surface of the cover 3.

This type of portal 1 has a number of disadvantages. The construction makes it difficult later to remove, replace or realign the portal 1 with the road surface without first grinding the road surface down to uncover the flange member 7a and allow the frame to be
5 raised.

This is particularly problematic when a road is to be resealed. As it is difficult and time consuming to lift the frame 2, it has become common to leave the portal 1 in place and reseal the road around the portal 1. This leaves a dip or hollow in the road surface at the
10 portal 1, as the portal 1 resides lower than the plane of the new road surface. The uneven road surface may in some cases be dangerous for road users.

A number of manufacturers have provided base panels which are adapted to engage with the under surface of the frame 2 and raise the portal 1 by a specific level. The
15 panels have been designed particularly for use with large portals 1 such as manholes.

However, the panels may only be produced in limited sizes (manhole portal sizes) for economic reasons. The road surface covering the base plate 4 must also be ground down to expose the frame member 7a before the portal can be raised to the new road
20 level and the panel inserted under the base plate 4. This is time consuming and expensive. For these reasons it has become common to delay raising manhole portals, for example, until the dip in the road surface becomes too great.

Ring extensions which engage with the side(s) 5 of the portal may also be available to
25 raise the height of the cover 3 to the road surface level. Ring extensions can be produced for large portals such as manhole portals or small portals, such as fire hydrants. Ring extensions raise the portals by a minimum of 50 millimetres. This is because ring extensions which are less than 50 millimetres are uneconomic to use and to manufacture.

30

Object of the Invention

It is the object of this invention to overcome or ameliorate at least one of the disadvantages of present utility portals and/or to at least provide the public with a useful
35 choice.

Other objects of the invention will become apparent from the following description.

Summary of the Invention

5

In accordance with one aspect of this invention, there is provided a utility portal frame including a base plate having an aperture to provide a portal entrance, and at least one wall dependent from the base plate, the wall extending substantially orthogonally relative to the base plate from an outer peripheral edge of the base plate.

10

Preferably the frame is adapted in use to be raised from a first position to a second position substantially without disturbance to material surrounding the at least one side wall.

15

In accordance with another aspect of this invention, there is provided a frame adapted to support a cover and the side wall which extends substantially upwardly from the base plate to such a height so as to substantially align with an upper surface of the cover when engaged with the frame.

20

Preferably, the side extends substantially orthogonally from the outer edges of a round or oval base plate.

Preferably, the frame is made from a substantially rigid or firm material.

25

Preferably, the frame is provided in a substantially rectangular, square or triangular configuration.

In accordance with a further aspect of this invention, there is provided a utility portal, including:

30

- a frame including a base plate and at least one wall which extends substantially orthogonally from an outer peripheral edge or edges of the base plate;
- a cover engageable with the frame

wherein said frame can in use be raised from a first position substantially below a new surface plane to a second position substantially to align with the new surface plane substantially without disturbance to the surface adjacent to the frame.

5 Preferably the frame includes an aperture of a size to allow a human to substantially pass through the frame.

Preferably the portal includes a frame provided in substantially round or oval, rectangular, square or triangular configuration.

10

Preferably the portal includes a side, extending substantially orthogonally from the outer edge of a round or oval base plate.

15 According to a further aspect of this invention there is provided a method of raising a utility portal frame having a base plate and a wall dependent from the base plate and extending substantially orthogonally relative to the base plate relative to an existing material surrounding the frame, the method including the steps of lifting the frame such that the wall slides upwardly relative to the surrounding material without substantially disturbing the surrounding material.

20

In accordance with a further aspect of this invention, there is provided a frame substantially as herein described with reference to any one of Figures 2, 3 and 4.

25 In accordance with a further aspect of this invention, there is provided a portal substantially as herein described with reference to any one of Figures 2, 3 and 4.

Brief Description of the Figures

30 The invention will now be described by way of example and with reference to the Figures in which:

Figure 1A illustrates a plan view of a prior art portal;

Figure 1B illustrates a cross-section view of the prior art portal;

35

- Figure 2A illustrates a plan view of a frame of one preferred embodiment of this present invention;
- Figure 2B illustrates a cross-section view of a portal, including the frame of Figure 2A, of one preferred embodiment of this invention;
- Figure 3A illustrates a plan view of a frame of an alternative preferred embodiment of the invention;
- Figure 3B illustrates a side view of the portal of Figure 3A; and
- Figure 4A illustrates a plan view of a frame including jacking points to allow the frame to be raised; and
- Figure 4B illustrates a cross-sectional view of the frame illustrating the jacking points of Figure 4A.

Description of the Invention

The invention will now be described with reference to one preferred embodiment.

Referring to Figures 2A and 2B, a preferred embodiment is shown which provides a utility portal 10. The portal unit 10 includes a portal frame 11 which is adapted in use to allow the frame 11 to be raised from a first position, below a new surface plane (such as a road surface) to a second position substantially aligned with the surface plane.

The utility portal 10 is adapted in use for positioning on any road, highway, motorway, footpath or like mounting surface. The portal 10 may have a variety of applications. For example, the portal 10 may be provided in a size such that the portal 10 may be used for a manhole portal. Alternatively, the portal 10 may be prepared in a size so that it can be used to cover fire hydrants or utility meters (such as power meters) in a road or footpath. It is also envisaged that the portal 10 could be provided in a form to allow it to engage with a wall surface to provide access to power cables or the like.

It will therefore be appreciated by those skilled in the art that the portal 10 may be provided in a variety of sizes and constructed from a variety of materials depending on a particular application for the portal 10.

5 Figure 2A illustrates a plan view of the frame 11. The frame 11 includes a base plate 13, at least one side wall 14, and includes an aperture 17 which in use allows access through the frame to facilities provided beneath a floor or transport surface such as a road surface.

10 Where the frame 11 is round such as that shown in Figure 2, a single side 14 extends around the outer peripheral edge of the base plate 13. When the frame 11 is polygonal, eg square, rectangular or triangular, the frame 11 may have more than one side, for example four sides 14 extending upwardly from outer peripheral edges of the base plate 13. The base plate 13 is adapted in the preferred embodiment to engage the frame 11
15 to a mounting surface. If the portal 10 is adapted for use as a manhole portal, the base plate 13 may be adapted to engage with a substantially horizontal concrete top which provides the entrance to a substantially vertical manhole shaft. The base plate 13 may, for example, include apertures (not shown in Figure 2A) to co-operate with both to connect the frame 11 to the mounting surface, as will be described with reference to
20 Figure 4A and 4B.

Preferably, the base plate 13 may be formed as a flat panel. This broadens the number of possible mounting surfaces to which the frame 11 may be engaged with. However, it is envisaged that the base plate 13 may be adapted and/or modified to engage with a
25 mounting surface which is not necessarily flat or is sloped, for example.

The base plate 13 and/or the wall 14 is adapted to receive, support or engage with the cover 12 as illustrated in Figure 2B. In the preferred embodiment, the base plate 13 provides a ledge or flange 20 to support the cover 12 when the cover 12 is engaged with
30 the frame 11.

As mentioned, the frame 11 includes at least one side wall 14 which is best illustrated with reference to a cross-sectional view of the portal unit 10 of Figure 2B. Figure 2B illustrates the cover 12 engaged with the frame 11. The side wall 14 encircles an outer
35 edge 21 of the base plate 13.

The side wall 14 extends substantially upwardly and/or substantially orthogonally to the base plate 13 from an outer edge or edges 21 of the base plate 13. The side wall 14 encircles the base plate 13 so that the side wall 14 is substantially parallel with itself at an opposite position of the frame. The side 14 is substantially perpendicular to the base plate.

The substantially orthogonal side 14 is adapted to allow the frame 11 to be raised from the first position to the second position to align with the plane of a new road or floor surface without requiring the existing surface (or stationary material from which the surface is formed) surrounding and/or adjacent the frame 11 to be substantially disturbed before the frame 11 is raised.

By contrast, to move a current portal as illustrated in Figures 1A and 1B requires the material surrounding the frame 2 to be removed to expose the flange member 7a before raising can take place. In the present invention the base plate 13 does not provide a flange member 7a extending substantially outwardly and beyond the side 14. This means that the frame 11 may be raised or removed easily and effectively without substantial excavation of the frame 11 or the adjacent surface of the road, for example.

The side wall 14 includes an inner surface 15 which aligns with the cover 12 and an outer surface 19 which is adjacent to the surrounding material in which the frame is mounted.

It should be understood that it is not essential that the inner surfaces 15 of the side wall 14 are substantially parallel as illustrated in Figures 2 and 3. In an alternative embodiment, the inner surface 15 may be tapered and/or grooved to provide co-operative engagement with the cover 12 which it is to be engaged with frame 11.

The side wall 14 may extend substantially upwardly from the base plate 13 by any desired height. However, preferably the side 14 extends to a height above the base plate 13 so that the side 14 aligns with a top surface 16 of the cover 12, when the cover 12 is engaged with the frame 11. A preferred embodiment of a portal unit 10 includes a frame 11 with a side 14 height between 80 mm to 150 mm but preferably 120 mm. This height is preferred where the portal unit 10 is to act as a manhole portal.

The portal 10 of Figures 2A and 2B may be substantially oval or circular. However, it will be understood that this is not essential to the operation of the invention. The invention may be equally applied to frames 11 which are rectangular, square or triangular as is
5 illustrated in Figure 3. Frames 11 with corners may also have some advantages in construction. The sides 14 can be formed by bending or otherwise forming edges of the base plate 13 at right angles to the base plate to provide the sides 14.

Figure 3A illustrates a plan view of a frame 11 of an alternative embodiment. The
10 frame 11 includes a base plate 13 and four sides 14. The sides 14 extend substantially upwardly from the base plate 13. Preferably the base plate 13 provides an internal flange or ledge 20 which is adapted in use to support a cover 12 when engaged with the frame 11. The side walls 14 extend orthogonally from the outermost edges of the base plate 13.

15 Figure 3B illustrates side walls 14 of the frame 11. The frame 11 may be easily raised or lowered as desired.

The portal 10 including frame 11 and cover 12 of the present invention may be made of
20 any firm and/or rigid material including metals, plastics, wood or the like. It will, however, be appreciated that the choice of material used to form the portal 10 may be dictated by use of a particular portal 10. For example, a portal 10 for use as a manhole portal 10 is preferably made from cast iron, steel, aluminium or plastic. Steel is of sufficient rigidity to withstand the weight of heavy vehicles passing over the portal 10 without substantially
25 damaging the portal 10 or components thereof.

The side walls 14 may be fixedly engaged to the base plate 13 so that they provide an orthogonal surface in a number of ways. The side wall 14 may simply be welded, bolted or glued to the base plate 13. Those skilled in the art will be aware of other methods
30 which may equally be used. Alternatively, if the frame 11 is square, the four side walls 14 may be formed by upturning the outer edges of the base plate 13 as mentioned above.

The portal 10 may be provided in any size depending on a particular application for the
35 portal 10. For example, a portal 10 which is to be used as an access portal 10 for a fire

hydrant or power cables may provide a frame 11 of about 40 cm x 15 cm. However, a portal 10 which is to be used as a manhole portal 10 may provide a frame 11 of a size of about 1 meter in diameter.

5 The width of the base portion may be between 60 mm to 120 mm, although a width of 80 mm has been found to be appropriate for frames 11 which are to be used for manhole portals. It is also desirable for the frames 11 which are to be used as manhole portals that the thickness of the or each side wall 14 be between 6 mm to 16 mm, but preferably 10 mm.

10

The frame 11 may optionally include a means for securing the frame 11 to the mounting surface. Figure 4A illustrates the frame 11 providing a base plate 13 with a means of securing the frame to a mounting surface 26 (not shown in Figure 4A) that is in use provided immediately beneath the mounting plate 13. The mounting surface will typically
15 be the upper edge of a concrete manhole shaft. The base plate 13 includes a plurality of apertures 22 spaced evenly around the frame and adapted to co-operate with bolts, screws, nuts or other securing means (not shown), to secure the frame 11 to the mounting surface. Alternatively, the frame 11 could have rods which extend from
20 beneath the base plate 13 of the frame 11 and which are adapted to pass through a concrete lid mounting surface (such as used over manhole shafts) or to engage with a concrete box. The rods may have a screw thread which allows nuts or the like to engage with the thread on the rod to anchor the frame 11 to the concrete lid.

Alternatively, the means for securing the frame 11 to a mounting surface may include
25 individual clamps which fasten the frame 11 to the mounting surface. The means of securing the frame 11 to the mounting surface should be sufficient to withstand the environment where the portal 10 is to be present. For example, the fastening means should withstand the vibrations and weight of traffic if the portal 10 is to be used as a manhole portal. However, the means should be able to be removed or loosened if
30 required to remove or raise the portal unit 10 and or the frame 11.

The frame may also provide a means of assisting jacking of the frame from the first position to the second position.

Figure 4B illustrates a cross-section through the frame 11 of Figure 4A raised to the second position to align with the plane of a new surface. The frame 11 includes jacking points 23 in the base plate 13 which are adapted to co-operate with jacks 24 to raise the frame from the first position to the second position. The jack point 23 includes an aperture 25 adapted to co-operate with the jack 24. The jack 24 may comprise a large bolt which engages with a corresponding thread provided in the jacking point 23. Thus, rotating the bolt in the required direction will raise the frame relative to the mounting surface 26. Once jacked, jams or packers may be secured beneath the frame 11 to maintain the new second position.

10

The invention also provides an improved method of raising a portal 10 from a first position below the plane of a new surface to a second position substantially aligned with the plane of the new surface when desired. For example, if a road surface is to be resealed, it may be desirable to raise the portal 10 so that the upper edge 27 of the side walls 14 is raised above the existing road surface 28 and the surrounding material 29 (for example roading material) so that the upper edge 27 is substantially in a new plane, corresponding to an intended new road surface 29 (such as a resealed road surface) as shown in Figure 4B.

15

The portal 10 may be secured to a mounting surface. If the portal 10 is to act as a manhole portal, the portal 10 may be secured to a substantially horizontal concrete top which covers a manhole shaft. The portal 10 includes a frame 11 and a cover 12 as shown in Figure 2B. As a manhole portal, the frame 11 is of a size adapted to allow access to an average size human. However, where the portal 10 is used to protect power cables or a fire hydrant, a smaller portal 10 may be desirable. Also, the shape of the portal unit 10 may be round, rectangular, square, triangular or any other desirable shape.

25

The frame 11 may be secured to a mounting surface by adhesives, bolts or the like as described above. Once the frame 11 is secured to the mounting surface, material such as concrete, tar seal, asphalt or the like may be spread around frame 11 so that the road surface is substantially aligned with the upper edges 27 of the side walls 14 of the frame 11.

30

When a road is to be resealed, the frame 11 may be lifted by removing the bolts and/or dissolving the adhesive which fastens the frame 11 to the mounting surface. The frame 11 may then be simply lifted or jemmied to a desired height (such as the height represented diagrammatically by lines 29 in Figure 4B). Jams and/or thin pieces of steel
5 may then be fastened under the base plate 13 to retain the frame 11 at the desired height. The frame 11 may be lifted by jacks 24 which engage with jacking points 23 to lift the frame 11 from the mounting surface.

Since the or each side wall 14 substantially orthogonal and as the base plate 13 does
10 include a flange portion 7a (of Figures 1A and 1B) which extends outwardly beyond the or each side wall 14, the frame 11 may be lifted substantially without disturbance to the surrounding material, and therefore without disturbance the existing surface 28 adjacent to the frame 11. Such disturbance would normally involve grinding down the road surface to expose the base plate 13 before raising the height of the frame 11.

15 Thus, a portal 10 and/or a frame 11 of the present invention simplifies the cost and time involved in raising or replacing a portal 10. The difficulty associated with removing or grinding down the road surface around the portal 10 may be avoided.

20 The invention may also be provided as a kit of parts including at least the frame 11. However, preferably the kit of parts for the portal 10 may be provided with a cover 12.

25 Where in the foregoing description reference has been made to specific components or integers of the invention having known equivalents, then such equivalents are herein incorporated as if individually set forth.

Although the invention has been described by way of example only and with reference to possible embodiments thereof, it is understood that modifications or improvements may be made thereto without departing from the scope of the invention.

CLAIMS

1. A utility portal frame including a base plate having an aperture to provide a portal entrance, and at least one wall dependent from the base plate, the wall extending
5 substantially orthogonally relative to the base plate from an outer peripheral edge of the base plate.
2. A frame according to claim 1 adapted in use to allow the frame to be raised from a first position to a second position substantially without disturbance to material
10 surrounding the at least one side wall.
3. A frame according to claim 1 or claim 2, wherein the frame is adapted to support a cover and the side wall extends substantially upwardly from the base plate to such a height so as to substantially align with an upper surface of the cover when
15 engaged with the frame.
4. A frame according to any of claims 1 to 3, wherein the side extends substantially orthogonally from the outer edges of a round or oval base plate.
- 20 5. A frame according to any one of the preceding claims wherein the or each side extends substantially orthogonally from the outer edges of polygonal or triangular base plate.
6. A frame according to any one of the preceding claims, wherein the frame is made
25 from a substantially rigid or firm material.
7. A frame according to any one of the preceding claims wherein the frame is provided in a substantially rectangular, square or triangular configuration.
- 30 8. A utility portal, including
 - a frame including a base plate and at least one wall which extends substantially orthogonally from an outer peripheral edge or edges of the base plate
 - a cover engageable with the frame;

wherein said frame can in use be raised from a first position substantially below a new surface plane to a second position to align with the new surface plane substantially without disturbance to an existing surface adjacent to the frame.

- 5 9. A portal according to claim 8, wherein the frame includes an aperture of a size to allow a human to substantially pass through the frame.
10. A portal according to claim 8 or 9, wherein the frame is provided in substantially round or oval, rectangular, square or triangular configuration.
- 10 11. A portal according to any one of claims 8 to 10 wherein the or each side extends substantially orthogonally from outer edges of a round or oval base plate.
12. A method of raising a utility portal frame having a base plate and a wall
15 dependent from the base plate and extending substantially orthogonally relative to the base plate relative to an existing material surrounding the frame, the method including the steps of lifting the frame such that the wall slides upwardly relative to the surrounding material without substantially disturbing the surrounding material.
- 20 13. A frame substantially as herein described with reference to any one of Figures 2, 3 and/or 4.
14. A portal substantially as herein described with reference to any one of Figures 2
25 3 and/or 4.

1/4

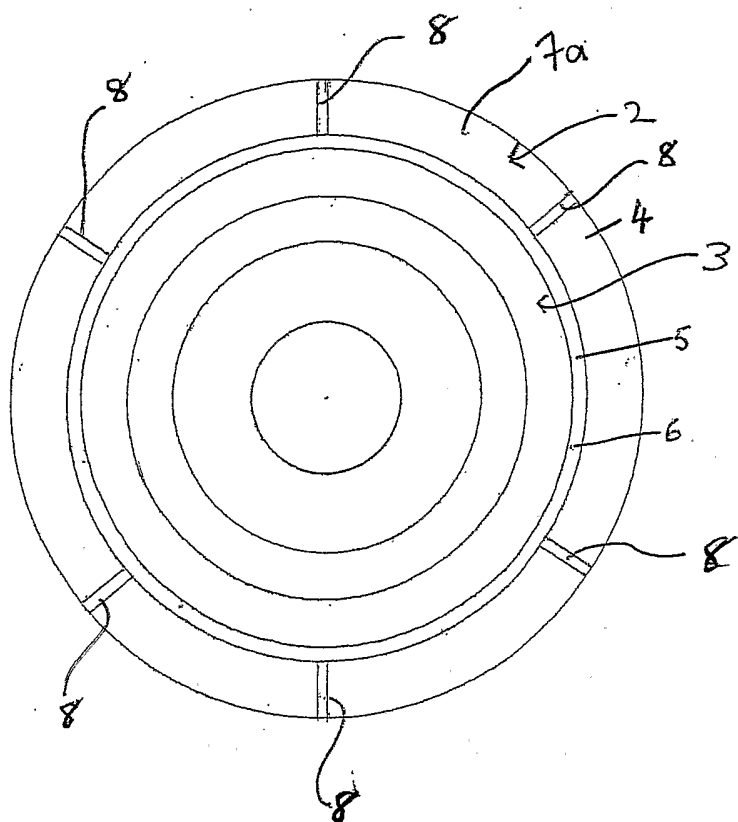
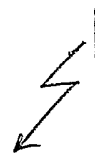

A

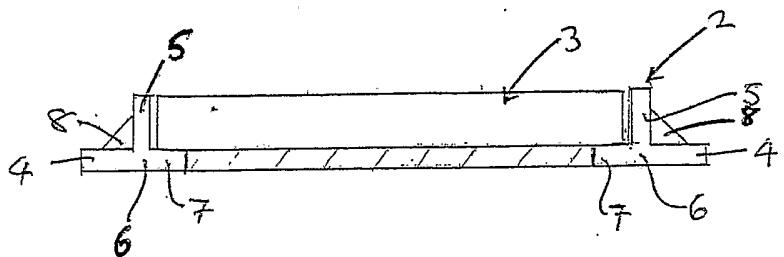

B

FIGURE 1

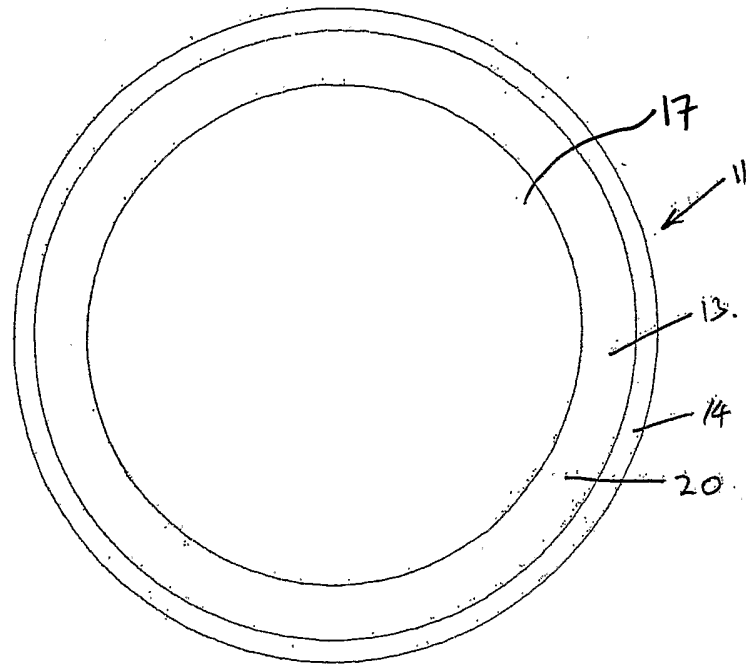

A

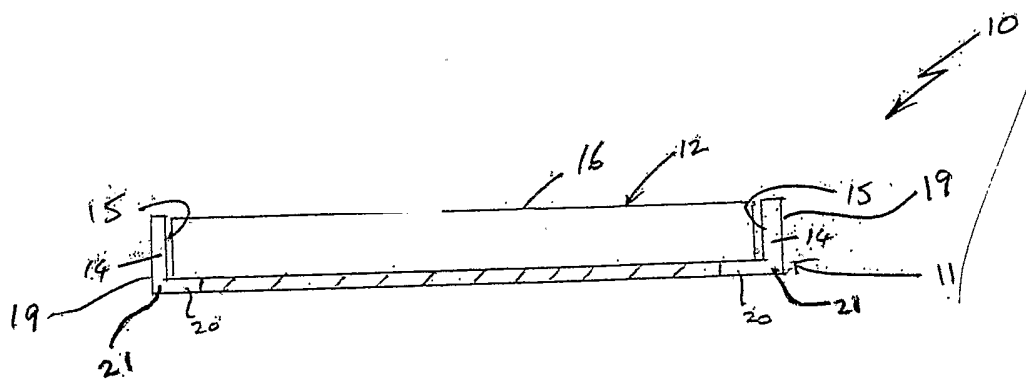

B

FIGURE 2

3/4

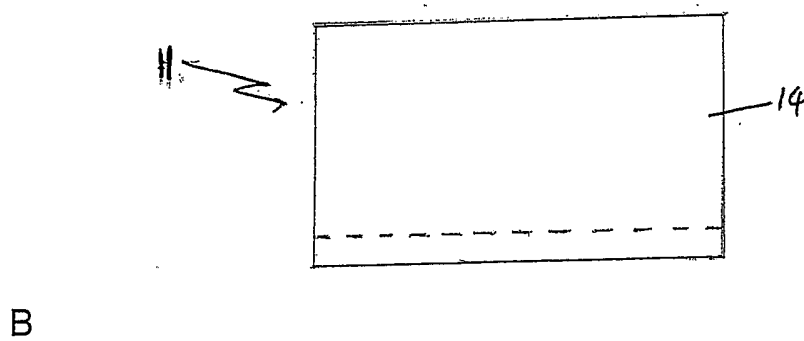
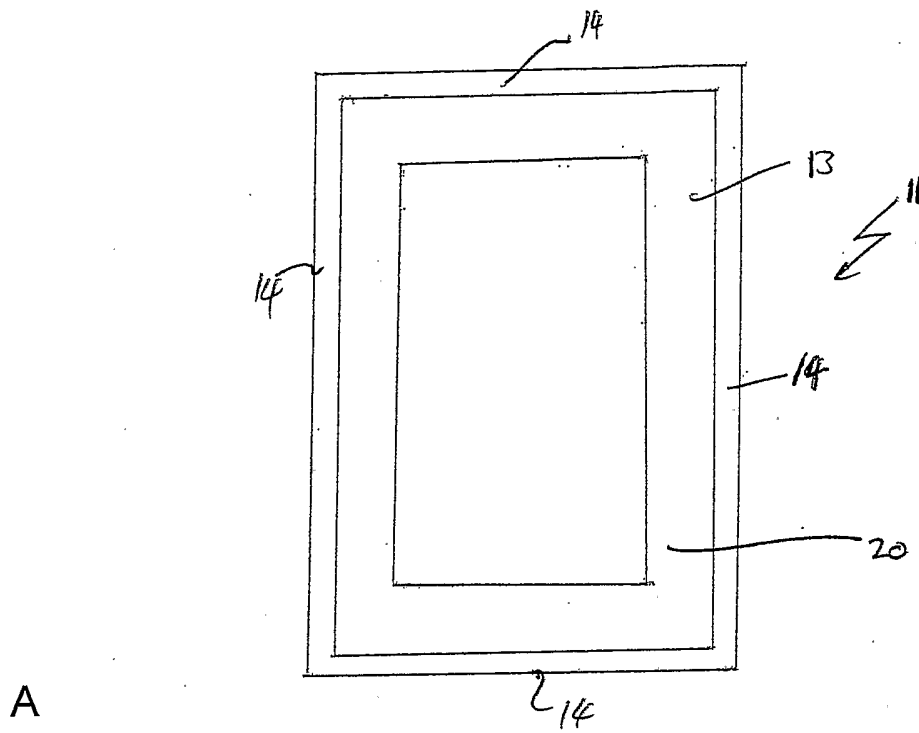

FIGURE 3

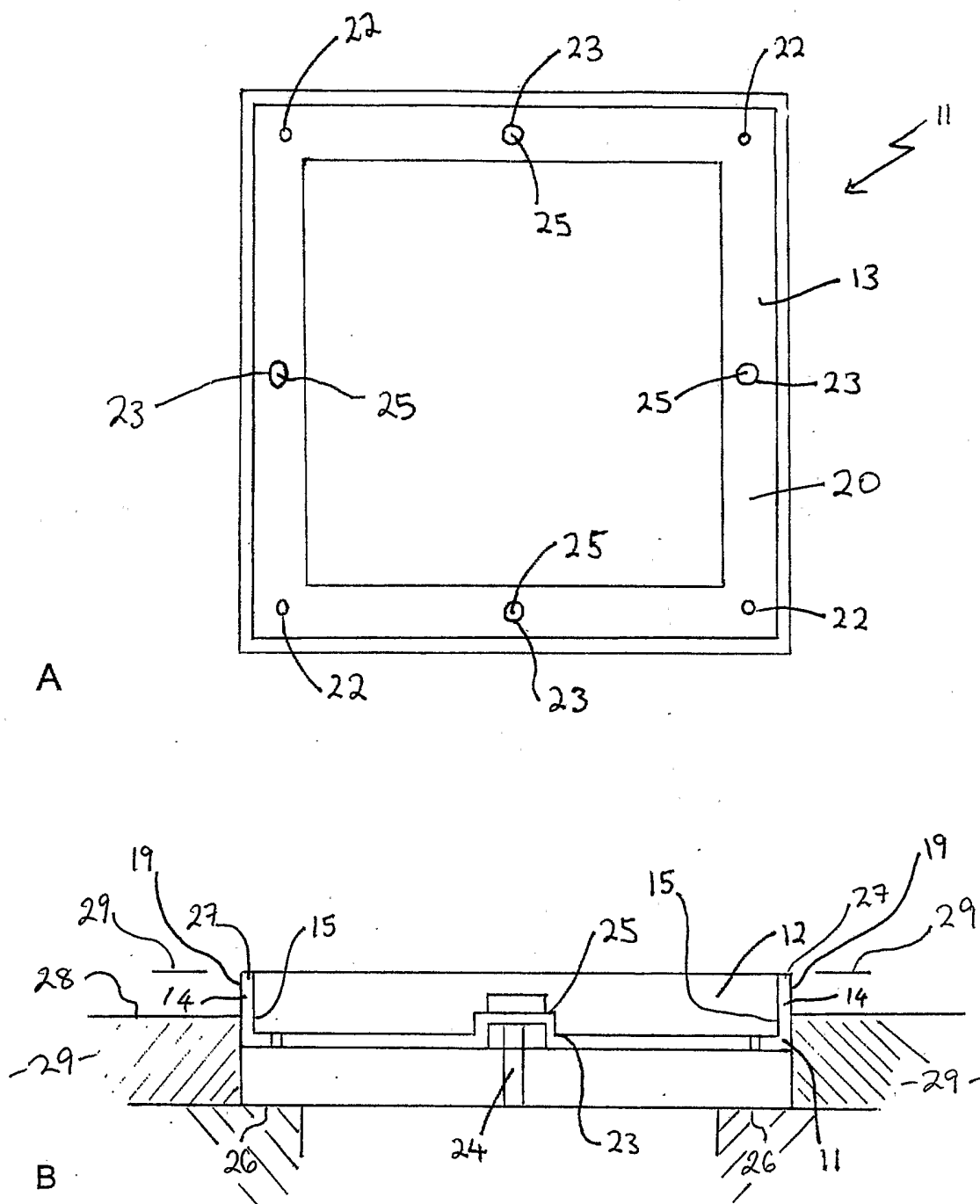

FIGURE 4

INTERNATIONAL SEARCH REPORT

International application No.

PCT/NZ2004/000127

A. CLASSIFICATION OF SUBJECT MATTER		
Int. Cl. 7: E02D 29/14		
According to International Patent Classification (IPC) or to both national classification and IPC		
B. FIELDS SEARCHED		
Minimum documentation searched (classification system followed by classification symbols)		
Documentation searched other than minimum documentation to the extent that such documents are included in the fields searched		
Electronic data base consulted during the international search (name of data base and, where practicable, search terms used) DWPI: IPC E02D 29/12, 29/14, E03F 5/02 and keywords (elevate, lift, wall, frame, edge, orthogonal) and like terms		
C. DOCUMENTS CONSIDERED TO BE RELEVANT		
Category*	Citation of document, with indication, where appropriate, of the relevant passages	Relevant to claim No.
X	WO 2000/068517 A1 (PONT-A-MOUSSON S.A.) 16 November 2000 See abstract, figure 10	1-14
X	EP 1 067 242 A1 (PONT-A-MOUSSON S.A.) 10 January 2001 See figure 2	1-14
X	EP 1 098 049 A1 (SANITRAP TECHNIC) 9 May 2001 See figures 1 and 4	1-14
X	FR 2 716 473 A1 (BARAT S.A.) 25 August 1995 See figures 1 and 2	1-14
<input checked="" type="checkbox"/> Further documents are listed in the continuation of Box C <input checked="" type="checkbox"/> See patent family annex		
* Special categories of cited documents:		
"A" document defining the general state of the art which is not considered to be of particular relevance	"T" later document published after the international filing date or priority date and not in conflict with the application but cited to understand the principle or theory underlying the invention	
"E" earlier application or patent but published on or after the international filing date	"X" document of particular relevance; the claimed invention cannot be considered novel or cannot be considered to involve an inventive step when the document is taken alone	
"L" document which may throw doubts on priority claim(s) or which is cited to establish the publication date of another citation or other special reason (as specified)	"Y" document of particular relevance; the claimed invention cannot be considered to involve an inventive step when the document is combined with one or more other such documents, such combination being obvious to a person skilled in the art	
"O" document referring to an oral disclosure, use, exhibition or other means	"&" document member of the same patent family	
"P" document published prior to the international filing date but later than the priority date claimed		
Date of the actual completion of the international search 30 July 2004	Date of mailing of the international search report - 5 AUG 2004	
Name and mailing address of the ISA/AU AUSTRALIAN PATENT OFFICE PO BOX 200, WODEN ACT 2606, AUSTRALIA E-mail address: pct@ipaaustralia.gov.au Facsimile No. (02) 6285 3929	Authorized officer S. GHOSH Telephone No : (02) 6283 2163	

INTERNATIONAL SEARCH REPORT

International application No.

PCT/NZ2004/000127

C (Continuation). DOCUMENTS CONSIDERED TO BE RELEVANT		
Category*	Citation of document, with indication, where appropriate, of the relevant passages	Relevant to claim No.
X	GB 1 496 899 (SELFLOCK LIMITED) 5 January 1978 See figure	1-14
A	US 5 944 442 (ROUSH et al) 31 August 1999 Whole document	1-14
A	US 2003 081999 A1 (GODFREY) 1 May 2003 Whole document	1-14

INTERNATIONAL SEARCH REPORT

Information on patent family members

International application No.

PCT/NZ2004/000127

This Annex lists the known "A" publication level patent family members relating to the patent documents cited in the above-mentioned international search report. The Australian Patent Office is in no way liable for these particulars which are merely given for the purpose of information.

Patent Document Cited in Search Report		Patent Family Member					
WO	0068517	AU	41269/00	BR	0010245	CA	2372784
		CZ	20013975	EP	1175533	FR	2793267
		HR	20010817	HU	0201236	NO	20015386
		PL	351318	SK	15892001	US	6676332
		ZA	200108709				
EP	1067242	BR	0002443	FR	2796092	ZA	200003354
EP	1098049	FR	2800763	MA	25216		
FR	2716473						
GB	1496899						
US	5944442						
US	2003081999						
Due to data integration issues this family listing may not include 10 digit Australian applications filed since May 2001.							
END OF ANNEX							