

A. GRAHAM.

BRIDGE FOR STRINGED INSTRUMENTS.

No. 521,909.

Patented June 26, 1894.

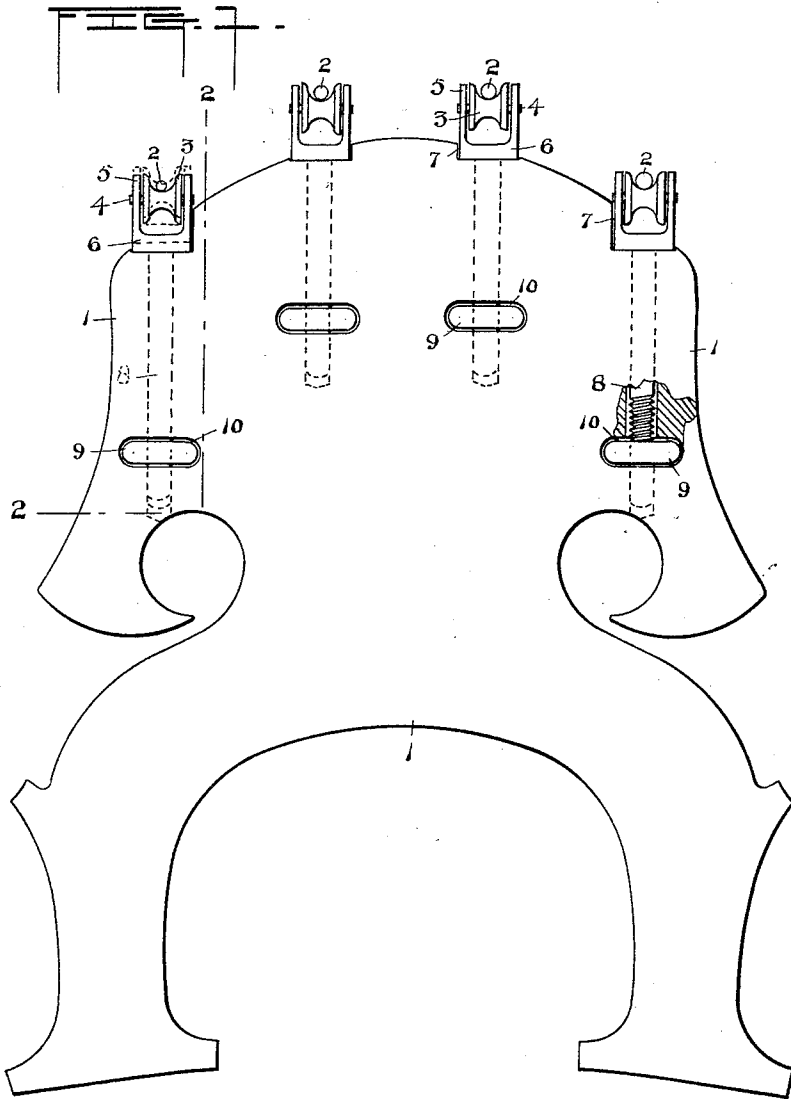

FIG. 1.

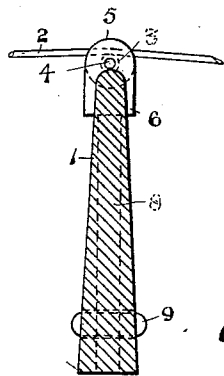

FIG. 2.

Witnesses
Arch. M. Cathin.
John C. Clark

Inventor
Andrew Graham
 by
Benj. R. Cathin Attorney

UNITED STATES PATENT OFFICE.

ANDREW GRAHAM, OF CLAREMONT, NEW HAMPSHIRE.

BRIDGE FOR STRINGED INSTRUMENTS.

SPECIFICATION forming part of Letters Patent No. 521,909, dated June 26, 1894.

Application filed January 2, 1894. Serial No. 495,402. (No model.)

To all whom it may concern:

Be it known that I, ANDREW GRAHAM, a resident of Claremont, in the county of Sullivan and State of New Hampshire, have invented certain new and useful Improvements in Bridges for Stringed Instruments; and I do hereby declare the following to be a full, clear, and exact description of the invention, such as will enable others skilled in the art to which it pertains to make and use the same.

The invention relates to stringed musical instruments; and has for its object to provide improved means for conveniently adjusting the relative distance of the strings from the finger board and also varying the tension of the strings without injury to them or to the bridge or other part, which means shall also be adapted to regulate the relative altitude or situation of the strings; and it consists in the construction hereinafter described and particularly pointed out.

In the accompanying drawings Figure 1 is a side elevation of a bass viol bridge, and Fig. 2 is a section on line 2—2 Fig. 1.

Numeral 1 denotes the bridge having any desired or usual contour and made of any suitable material.

2 denotes the viol strings.

3 denote small pulleys having axes 4 supported to turn in bearings in the small posts 5 forming part of the bracket or screw-heads 6. These may be fitted in recesses 7 in the upper edge of the bridge and are preferably fixed on the screw rods 8. They are suitably arranged at different elevations around the curved upper edge of the bridge as indicated. The greater part of each of them can be concealed in the bridge and each has preferably a milled screw threaded nut 9 situated in a transverse slot 10 in the bridge and adapted to be turned with the effect to raise or lower the rod and its head and pulley according to the direction in which said nut is turned with the effect to raise or lower the string and to vary its tension.

It will be obvious that any desired height can be given to each string and also that its tension can be quickly and conveniently varied as required in tuning by simply turning the milled nut and without pulling the bridge lengthwise of the string, as in the usual construction wherein the tuning is effected by

straining the strings at their ends. Not only do the friction pulleys tend to obviate the pulling over of the bridge but also the fact that tension is applied to them in the plane of the bridge and without a pull such as caused by winding the ends of the string. My improved means not only avoids a dangerous strain on the bridge and warping of the same and the wearing of its crown but it also prevents the cutting or wearing of the strings upon the bridge.

Any suitable material may be employed but I have found a composition or alloy very suitable for the nuts, bracket or screw heads and pulleys and steel for the screw rods and pulley pivots. The improvement is however not confined to the use of any particular material nor to any particular instrument as it is applicable to all musical instruments having a bridge intermediate the ends of the strings and in which an adjustment of individual strings relative to the finger board as well as an individual straining of the same is required.

I am aware that a bridge has been made adjustable by means of supports at its ends whereby all the strings were affected by any adjustment thereof and I am also aware that the ends of piano strings have been each passed around a pulley having an adjustable support any increase in the tension of the strings being effected by a direct pull lengthwise of the same.

My improvement is intended to obviate the serious evil in bass viols and like instruments having a string supporting bridge intermediate the end fastenings of the strings, heretofore occasioned by straining the strings from their ends and for this purpose I use means that act on the strings singly and transversely to their length and in the direction of the plane of the bridge whereby warping of the same is avoided and whereby each string can be separately adjusted, and tuned if desired, and whereby friction between the bridge and the strings is much diminished, and the necessity of "trimming" and also of notching heretofore required in bridges, and also the wearing of the strings upon the same, is avoided.

Having thus described my improvement, what I claim is—

1. In a stringed instrument having a bridge for the support of the strings intermediate their ends, movable string bearings supported in the top of the bridge, and devices for separately raising or lowering the bearings, substantially as set forth.
2. In a stringed instrument having a bridge for the support of the strings intermediate their ends, a pulley for each string, and devices for separately raising or lowering each pulley, said devices comprising a nut situated in a transverse slot in the bridge and a screw rod situated in the plane of the bridge and adjustable by said nut, substantially as set forth.
- In testimony whereof I have signed this specification in the presence of two subscribing witnesses.
- ANDREW GRAHAM.
- Witnesses:
CHARLES L. FOSS,
HOWARD C. WHITE.