



- (51) International Patent Classification:
E21B 17/10 (2006.01) *E21B 41/00* (2006.01)
- (21) International Application Number:
PCT/US2016/065701
- (22) International Filing Date:
9 December 2016 (09.12.2016)
- (25) Filing Language: English
- (26) Publication Language: English
- (30) Priority Data:
14/964,223 9 December 2015 (09.12.2015) US
- (71) Applicant: **BAKER HUGHES INCORPORATED**
[US/US]; 17021 Aldine Westfield, Houston, TX 77073
(US).
- (72) Inventors: **BERNARD, Stephan**; Hornbostelstrabe 14,
29221 Celle (DE). **BUDA, Robert**; Sehndenstrabe 2,
29223 Celle (DE).
- (74) Agent: **CARSON, Matt, W.**; Baker Hughes Incorporated,
Intellectual Property Counsel, 17021 Aldine Westfield,
Houston, TX 77073 (US).
- (81) Designated States (unless otherwise indicated, for every
kind of national protection available): AE, AG, AL, AM,
AO, AT, AU, AZ, BA, BB, BG, BH, BN, BR, BW, BY,
BZ, CA, CH, CL, CN, CO, CR, CU, CZ, DE, DJ, DK, DM,

DO, DZ, EC, EE, EG, ES, FI, GB, GD, GE, GH, GM, GT,
HN, HR, HU, ID, IL, IN, IR, IS, JP, KE, KG, KH, KN,
KP, KR, KW, KZ, LA, LC, LK, LR, LS, LU, LY, MA,
MD, ME, MG, MK, MN, MW, MX, MY, MZ, NA, NG,
NI, NO, NZ, OM, PA, PE, PG, PH, PL, PT, QA, RO, RS,
RU, RW, SA, SC, SD, SE, SG, SK, SL, SM, ST, SV, SY,
TH, TJ, TM, TN, TR, TT, TZ, UA, UG, US, UZ, VC, VN,
ZA, ZM, ZW.

- (84) Designated States (unless otherwise indicated, for every
kind of regional protection available): ARIPO (BW, GH,
GM, KE, LR, LS, MW, MZ, NA, RW, SD, SL, ST, SZ,
TZ, UG, ZM, ZW), Eurasian (AM, AZ, BY, KG, KZ, RU,
TJ, TM), European (AL, AT, BE, BG, CH, CY, CZ, DE,
DK, EE, ES, FI, FR, GB, GR, HR, HU, IE, IS, IT, LT, LU,
LV, MC, MK, MT, NL, NO, PL, PT, RO, RS, SE, SI, SK,
SM, TR), OAPI (BF, BJ, CF, CG, CI, CM, GA, GN, GQ,
GW, KM, ML, MR, NE, SN, TD, TG).

Declarations under Rule 4.17:

- as to applicant's entitlement to apply for and be granted a patent (Rule 4.17(ii))
- as to the applicant's entitlement to claim the priority of the earlier application (Rule 4.17(iii))

Published:

- with international search report (Art. 21(3))

(54) Title: PROTECTION OF DOWNHOLE TOOLS AGAINST MECHANICAL INFLUENCES WITH A PLIANT MATERIAL

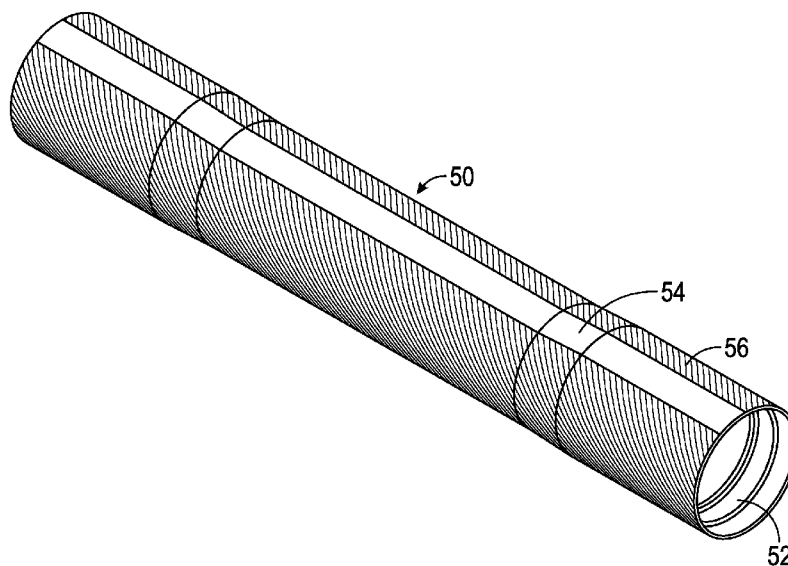

FIG. 2

(57) Abstract: A downhole tool in a wellbore may be at least partially enclosed by a protector. The protector may form a physical barrier between the downhole tool and a wellbore environment. The protector include a sheath formed of a pliant material or a textile and may include one or more hard inserts.



-1-

**TITLE: PROTECTION OF DOWNHOLE TOOLS AGAINST
MECHANICAL INFLUENCES WITH A PLIANT
MATERIAL**

BACKGROUND OF THE DISCLOSURE

1. Field of the Disclosure

[0001] This disclosure relates generally to arrangements and related methods for protecting oilfield downhole tools from mechanical wear.

2. Background of the Art

[0002] To obtain hydrocarbons such as oil and gas, boreholes or wellbores are drilled by rotating a drill bit attached to the bottom of a drilling assembly (also referred to herein as a "Bottom Hole Assembly" or ("BHA")). The drilling assembly is attached to tubing, which is usually either a jointed rigid pipe or flexible spoolable tubing commonly referred to in the art as "coiled tubing." The string comprising the tubing and the drilling assembly is usually referred to as the "drill string." When jointed pipe is utilized as the tubing, the drill bit is rotated by rotating the jointed pipe from the surface and/or by a mud motor contained in the drilling assembly. In the case of a coiled tubing, the drill bit is rotated by the mud motor. During drilling, a drilling fluid (also referred to as the "mud") is supplied under pressure into the tubing. The drilling fluid passes through the drilling assembly and then discharges at the drill bit bottom. The drilling fluid provides lubrication to the drill bit and carries to the surface rock pieces disintegrated by the drill bit in drilling the wellbore. The mud motor is rotated by the drilling fluid passing through the drilling assembly. A drive shaft connected to the motor and the drill bit rotates the drill bit.

[0003] During wellbore operations, downhole tools with sensitive outer parts and / or equipment can be subjected to mechanical influences, such as abrasion, chipping and cuttings and chemical influences resulting from a direct contact with the

-2-

mud flow. Prior to operation, downhole how tools may be subjected to electromagnetic radiation coming from tools storage and transportation on the ground. The present disclosure addresses the need to protect these sensitive parts and equipment.

SUMMARY OF THE DISCLOSURE

[0004] In aspects, the present disclosure provides an apparatus for use in a wellbore. The apparatus may include a downhole tool configured to physically transform to execute a specified downhole operation and a protector at least partially enclosing the downhole tool. The protector may form a physical barrier between the downhole tool and a wellbore environment. The protector may include a sheath formed of a pliant material.

[0005] In aspects, the present disclosure also provides an apparatus that includes a downhole tool configured to be conveyed into a wellbore to perform a specified downhole function and a protector at least partially enclosing the downhole tool. The protector may form a physical barrier between the downhole tool and a wellbore environment. The protector may include a sheath formed at least partially of a textile.

[0006] In aspects, the present disclosure further provides a method for using a downhole tool in a wellbore. The method may include at least partially enclosing the downhole tool using a protector; conveying the downhole tool and the protector into the wellbore, and executing a specified downhole operation. The protector may form a physical barrier between the downhole tool and a wellbore environment and include a sheath formed of a pliant material or a textile. The specified downhole operation may be executed by physically transforming the downhole tool.

[0007] Examples of certain features of the disclosure have been summarized rather broadly in order that the detailed description thereof that follows may be better understood and in order that the contributions they represent to the art may be appreciated. There are, of course, additional features of the disclosure that will be

described hereinafter and which will form the subject of the claims appended hereto.

BRIEF DESCRIPTION OF THE DRAWINGS

[0008] For a detailed understanding of the present disclosure, reference should be made to the following detailed description of the embodiments, taken in conjunction with the accompanying drawings, in which like elements have been given like numerals, wherein:

FIG. 1 illustrates a drilling system made in accordance with one embodiment of the present disclosure;

FIG. 2 schematically illustrates a protector for a downhole tool made in accordance with one embodiment of the present disclosure;

FIG. 3 schematically illustrates a protector integrated into a downhole tool in accordance with one embodiment of the present disclosure;

FIGS. 4A and **4B** illustrate inserts that may be used with protectors in accordance with the present disclosure.

-4-

DETAILED DESCRIPTION OF THE DISCLOSURE

[0009] As will be appreciated from the discussion below, aspects of the present disclosure provide protection arrangements that use a pliant material to protect downhole tools from mechanical wear. Mechanical wear includes, but is not limited to, abrasion, chipping, fracturing, cracking, cutting, etc. In some embodiments, the pliant material may be a textile, *e.g.*, a braided, knitted or woven fabric with optional wear-resistant inserts. While the discussion below is set in the context of a drilling system, it should be understood that the teachings of the present disclosure may be used in all phases of well construction and production (*e.g.*, drilling, completion, production, workover, etc.).

[0010] Referring now to **FIG. 1**, there is shown one illustrative embodiment drilling system **10** that includes a bottomhole assembly (BHA) **12** for drilling a wellbore **14**. The wellbore **14** has a vertical section **16** and a deviated section **17**. While shown as horizontal, the deviated section **17** may have any inclination or inclinations relative to vertical. Also, while a land-based rig is shown, these concepts and the methods are equally applicable to offshore drilling systems. The system **10** may include a drill string **18** suspended from a rig **20**. The drill string **18**, which may be jointed tubulars or coiled tubing, may include power and/or data conductors such as wires for providing bidirectional communication and power transmission. In one configuration, the BHA **12** includes a drill bit **30**, a steering assembly **32** that steers the drill bit **30**, a drilling motor **34** for rotating the drill bit **30**, and a measurement-while-drilling (MWD) section **36**.

[0011] Some of the tooling and equipment of the drill string **18** and the BHA **12** do not change shape or dimensions in order to operate as intended. Other tools undergo a physical transformation as part of their intended operation. A physical transformation can include a change in shape, size, or dimensions. Illustrative transformations include, but are not limited to, expansion, contraction, twisting, shifting, etc. By way of illustration, there is shown a packer device **40** positioned along the drill string **18**. The packer device **40** may include an expandable annular

-5-

sealing element. When activated, the packer device **40** may radially expand into a sealing engagement with an adjacent surface, such as a borehole wall.

[0012] Referring now to **Fig. 2**, there is shown a downhole tool protector **50** that may be used to protect one or more downhole tools **52** of the drilling system **10** from mechanical wear. The downhole tool **52** may be physically static or undergo a physical deformation. The protector **50** encloses the downhole tool **52** and forms a physical barrier between the downhole tool **52** and the wellbore environment. The protector **50** may partially surround the downhole tool **52** by covering only the sensitive sections or completely surround the downhole tool **52**. In the **Fig. 2** embodiment, the protector **50** is external to and contacts an outer surface **54** of the downhole tool **52**. Thus, debris or fluids in an annulus surrounding the downhole tool **52** contact the protector **50** instead of the outer surface **54** of the downhole tool **52**.

[0013] In one embodiment, the protector **50** includes a sheath **56** that is formed of a pliant material. As used herein, a pliant material is a material that can physically transform or physically degrade. By physically transform, it is meant that the pliant material accommodates the physical transformation of the downhole tool **52** by also physically transforming (e.g., expanding, stretching, bending, etc.). Thus, in this arrangement, the sheath **56** is not damaged by the transformation. By physically degrade, it is meant the pliant material breaks up or otherwise structurally destabilizes while the downhole tools **52** physically transforms. In either case, the pliant material does not impede or prevent the physical transformation of the downhole tool **52**.

[0014] A number of methodologies may be used to form the pliant material. For instance, a material having a modulus of elasticity that allows a preset amount of deformation and subsequent structural failure may be used. Alternatively or additionally, the sheath **56** may be formed with grooves, holes, or other features that initiate failure after a predetermined amount of deformation. In still other instances, the pliant material may be textile. As used herein, a textile may be structured as netting, knitting, braiding, weaving, meshing, lacing, or any other interconnection of fibers or strands. The material of the textile may be a mineral or synthetic. Illustrative mineral materials include, but are not limited to, glass fibers, metal fibers

-6-

and metal wires. Synthetic textiles include, but are not limited to, polyester, aramid, acrylic, nylon, polyurethanes, olefins, and polylactides. Additionally, the material of the protector may include a coating of a secondary material to increase functionality.

[0015] In some embodiments, the sheath **56** may be constructed as a sacrificial layer that uses a material selected to resist wear long enough while being deployed downhole so that the underlying downhole tool is not physically compromised.

[0016] The sheath **56** may be formed as a sleeve that surrounds the downhole tool **52**. In other embodiments, the sheath **56** may be wrapping that is layered around the downhole tool **52**. In both instances, the sheath **56** is structurally separate from the underlying downhole tool **52**.

[0017] Referring to **Fig. 3**, there is shown another embodiment of a protector **50**. In the **Fig. 3** embodiment, the protector **50** is integrated into the outer surface **54** of the downhole tool **52**. For example, the outer surface **54** may be formed of an elastomer such as rubber. Thus, the sheath **56** of the protector **50** may be embedded into the outer surface **54**. By structurally integrated, it is meant that the material of the protector **50** and the material of the downhole tool **52** are not separated along a contiguous contact area. Instead, the materials are mixed or otherwise intricately bound with one another.

[0018] Referring now to **Figs. 4A** and **4B**, there are shown inserts **60** that may be integrated into the protector **50**. The insert **60** may be formed of a material harder than the material of the sheath **56**. In one non-limiting embodiment, the insert **60** may be formed of a metal carbide or other material that has very high wear resistance. Illustrative materials include, but are not limited to, silicon carbides, metals, metal alloys (e.g., steel), etc. In some arrangements, any material having a property that provides a wear resistance higher than that of the material of the sheath **56** may be used. Illustrative material properties include, but are not limited to, hardness, toughness, ductility, tensile strength, resilience, etc. In other arrangements, the insert **60** may be formed of the same material as the sheath **56**, but shaped or dimension to

-7-

act as a shield or “stand-off” that contacts an object before such an object contacts the sheath **56**. The insert **60** may have opposing wear faces **62** that are connected by a neck **64**. During the production of the fabric of the protector **50**, the inserts **60** may be integrated into the fabric as shown in **Fig. 4**. The relatively smaller neck **64** allows the inserts **60** to be physically captured within the sheath **56**. The inserts **60** may be shaped to ensure a tight seat within the fabric’s structure at any point even while the fabric’s deformation and only allows removal upon destruction of the fabric. In case of loss, the inserts **60** can easily be carried out of the bore by the mud flow.

[0019] The inserts **60** may provide protection in two ways. First, the inserts **60** may provide better wear resistance than the base material. Second, the inserts **60** may act as a guard or shield for the base material. That is, the inserts **60** may protect against the mechanical influence resulting from a contact with the borehole wall while the sheath **56** protects against cuttings. Thus, if there are hook-like structure on the borehole wall, the pliant material making up the sheath **56** is protected from continuously tearing single fibers, which would weaken the entire protector **50** until failure.

[0020] The operating mode of the protector **50** depends, in part, on the behavior of the tool to be protected. Some non-limiting operating modes are discussed below with references to **Figs. 1 – 4A-B**.

[0021] In applications where the downhole tool **52** does not physically deform, the sheath **56** of the protector **50** may be formed using a textile, either with or without the inserts **60**. At the surface, the sheath **56** may protect the downhole tool **52** during handling and transport, and possibly shield the downhole tool **52** from electromagnetic energy. Downhole, the sheath **56** may provide protection from mechanical wear. The sheath **56** may be structurally separate from or embedded in the downhole tool **52**.

[0022] In applications where the downhole tool **52** does physically deform, the sheath **56** of the protector **50** may be formed using a pliant material, which may optionally be a textile and may optionally include the inserts **60**. As before, the

-8-

surface, the sheath **56** may protect the downhole tool **52** during handling and transport, and possibly from exposure to electromagnetic energy. Downhole, the sheath **56** may provide protection from mechanical wear. The sheath **56** may be structurally separate from or embedded in the downhole tool **52**.

[0023] As noted above, the downhole tool **52**, when activated, may physically transform (e.g., expand) in order to perform a specified downhole operation. By downhole operation, it is meant an act or process affecting the wellbore **14**, the formation surrounding the wellbore **14**, a fluid native to the formation, a fluid in the wellbore, and / or another downhole tool. For instance, a packer may be expanded to hydraulically isolate a portion of a wellbore. The protector **50** can have at least two distinct responses. The protector **50** may expand and fully accommodate the transformation of the downhole tool **52**. In this response, the protector **50** retains structural integrity and continues to provide protection after the underlying tool changes shape or deforms. In another response, the protector **50** may partially or completely physically degrades to allow the underlying downhole tool **52** to transform (e.g., expand, twist, axially shift, etc.). For example, the protector **50** may fray, break, snap, etc.

[0024] As used above, the term “mechanical wear” or “mechanical influence” refers to a degradation of an object due principally to physical contact with another object. This is in contrast to chemical influence in which a chemical reaction principally causes the degradation or radiation influence wherein an energy wave or beam principally causes the degradation.

[0025] While the foregoing disclosure is directed to the one mode embodiments of the disclosure, various modifications will be apparent to those skilled in the art. It is intended that all variations within the scope of the appended claims be embraced by the foregoing disclosure.

-9-

THE CLAIMS

1. An apparatus for use in a wellbore, characterized by:
 - a downhole tool (52) configured to physically transform to execute a specified downhole operation; and
 - a protector (50) at least partially enclosing the downhole tool (52) and forming a physical barrier between the downhole tool (52) and a wellbore environment, the protector (50) including a sheath (56) formed of a pliant material.
2. The apparatus of claim 1, further characterized in that the sheath (56) is structurally integrated into the downhole tool (52).
3. The apparatus of claim 1, further characterized in that the protector (50) continues to at least partially enclose the downhole tool (52) after the downhole tool (52) has completed a physical transformation.
4. The apparatus of claim 1, further characterized in that the protector (50) structurally degrades while the downhole tool (52) physically transforms.
5. The apparatus of claim 1, further characterized in that: the downhole tool (52) is an expandable packer, the pliant material includes a textile, and the sheath (56) is structurally separate from the downhole tool (52).
6. A method for using a downhole tool (52) in a wellbore, characterized by:
 - at least partially enclosing the downhole tool (52) using a protector (50), the protector (50) forming a physical barrier between the downhole tool (52) and a wellbore environment, the protector (50) including a sheath (56)

-10-

formed of at least one of: a pliant material, and a textile;

- conveying the downhole tool (52) and the protector (50) into the wellbore; and
- executing a specified downhole operation.

7. The method of claim 6, further characterized in that the specified downhole operation is executed by physically transforming the downhole tool (52).

8. The method of claim 7, further characterized in that the protector (50) continues to at least partially enclose the downhole tool (52) after the downhole tool (52) has completed the physical transformation.

9. The method of claim 7, further characterized in that the protector (50) structurally degrades while the downhole tool (52) physically transforms.

10. The method of claim 6, further characterized in that the sheath (56) is formed at least partially of one of: (i) glass fibers, (ii) metal fibers, (iii) metal wires, and (iv) a polymeric fiber.

11. The method of claim 6, further characterized in that the sheath (56) is structurally separate from the downhole tool (52).

12. The method of claim 6, further characterized in that the sheath (56) is structurally integrated into the downhole tool (52).

13. The method of claim 6, further characterized in that the sheath (56) includes at

-11-

least one insert formed of a material harder than the pliant material.

14. The method of claim 6, further characterized in that the sheath (56) is formed at least partially of the textile.

15. The method of claim 14, further characterized in that the textile is structured as at least one of: netting, knitting, braiding, weaving, meshing, and lacing.

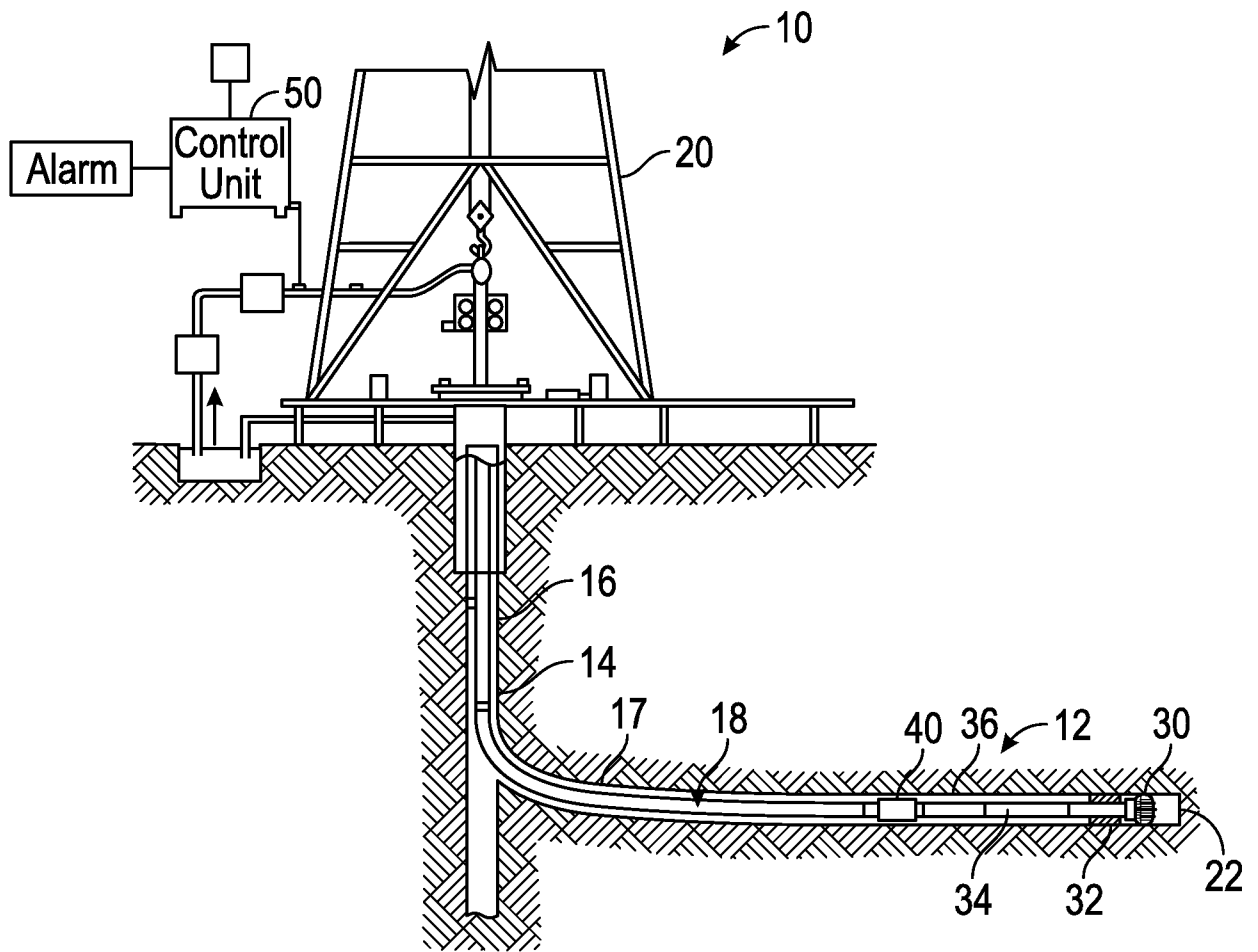

FIG. 1

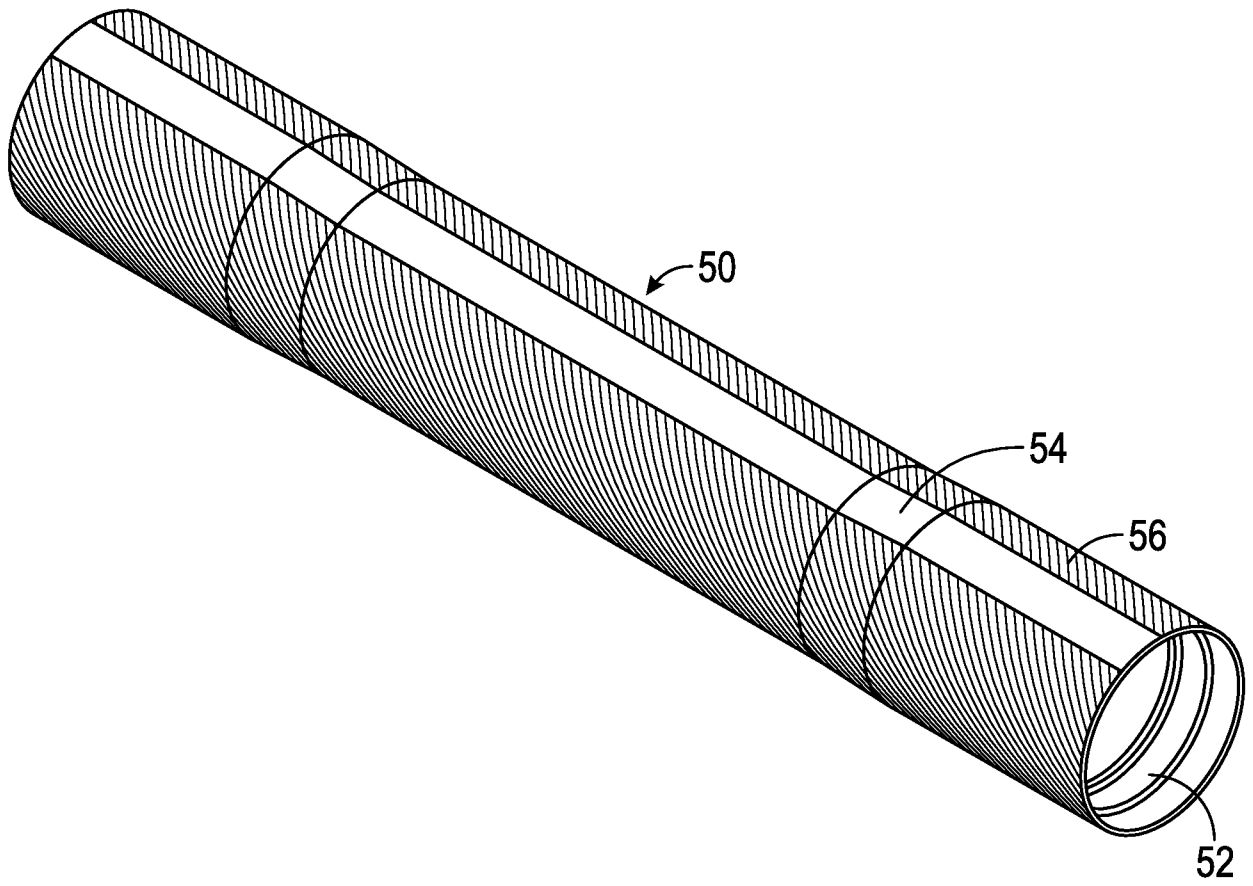

FIG. 2

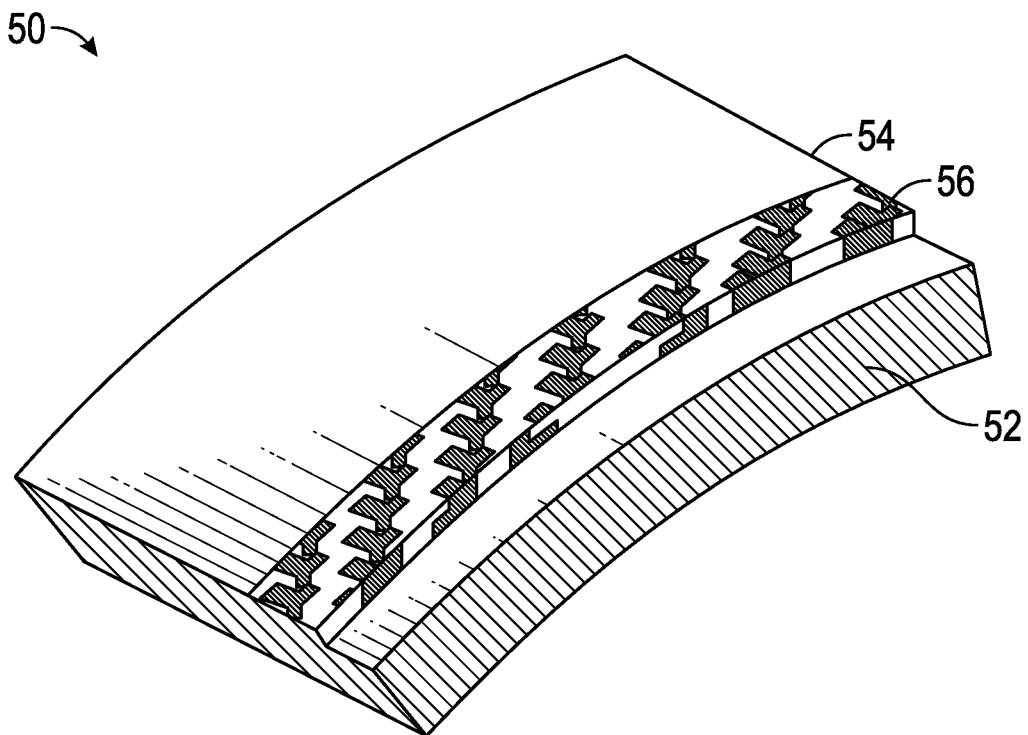

FIG. 3

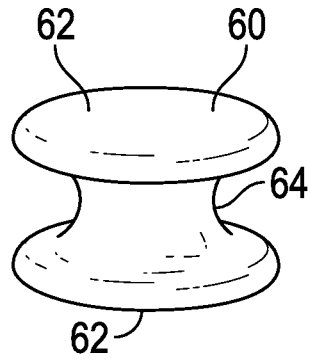

FIG. 4A

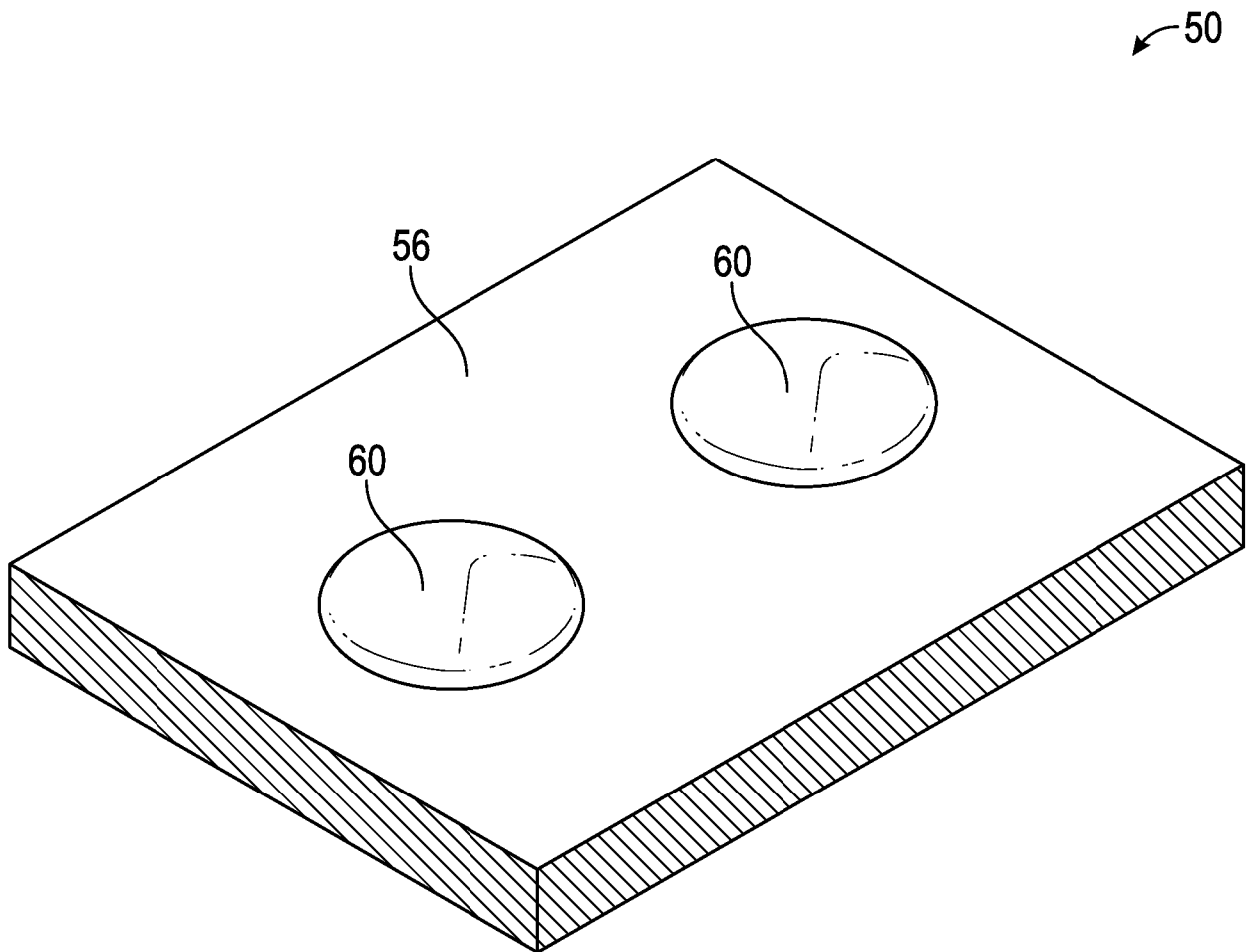

FIG. 4B

PATENT COOPERATION TREATY

PCT

INTERNATIONAL SEARCH REPORT

(PCT Article 18 and Rules 43 and 44)

Applicant's or agent's file reference DRL4-59579-WO	FOR FURTHER ACTION see Form PCT/ISA/220 as well as, where applicable, item 5 below.	
International application No. PCT/US2016/065701	International filing date (<i>day/month/year</i>) 09 December 2016 (09.12.2016)	(Earliest) Priority Date (<i>day/month/year</i>) 09 December 2015 (09.12.2015)
Applicant BAKER HUGHES INCORPORATED		

This International search report has been prepared by this International Searching Authority and is transmitted to the applicant according to Article 18. A copy is being transmitted to the International Bureau.

This international search report consists of a total of 3 sheets.

It is also accompanied by a copy of each prior art document cited in this report.

1. **Basis of the report**

a. With regard to the **language**, the international search was carried out on the basis of:

the international application in the language in which it was filed

a translation of the international application into _____, which is the language of a translation furnished for the purposes of international search (Rules 12.3(a) and 23.1(b))

b. This international search report has been established taking into account the **rectification of an obvious mistake** authorized by or notified to this Authority under Rule 91 (Rule 43.6bis(a)).

c. With regard to any **nucleotide and/or amino acid sequence** disclosed in the international application, see Box No. I.

2. **Certain claims were found unsearchable** (See Box No. II)

3. **Unity of invention is lacking** (See Box No. III)

4. With regard to the **title**,

the text is approved as submitted by the applicant.

the text has been established by this Authority to read as follows:

5. With regard to the **abstract**,

the text is approved as submitted by the applicant.

the text has been established, according to Rule 38.2, by this Authority as it appears in Box No. IV. The applicant may, within one month from the date of mailing of this international search report, submit comments to this Authority.

6. With regard to the drawings,

a. the figure of the **drawings** to be published with the abstract is Figure No. 2

as suggested by the applicant.

as selected by this Authority, because the applicant failed to suggest a figure.

as selected by this Authority, because this figure better characterizes the invention.

b. none of the figures is to be published with the abstract.

A. CLASSIFICATION OF SUBJECT MATTER**E21B 17/10(2006.01)i, E21B 41/00(2006.01)i**

According to International Patent Classification (IPC) or to both national classification and IPC

B. FIELDS SEARCHEDMinimum documentation searched (classification system followed by classification symbols)
E21B 17/10; E21B 33/12; E21B 19/00; F16J 15/48; E21B 23/01; E21B 41/00Documentation searched other than minimum documentation to the extent that such documents are included in the fields searched
Korean utility models and applications for utility models
Japanese utility models and applications for utility modelsElectronic data base consulted during the international search (name of data base and, where practicable, search terms used)
eKOMPASS(KIPO internal) & Keywords: wellbore, downhole tool, protector, physical barrier, sheath, pliant material**C. DOCUMENTS CONSIDERED TO BE RELEVANT**

Category*	Citation of document, with indication, where appropriate, of the relevant passages	Relevant to claim No.
X	US 2008-0223571 A1 (MURRAY, DOUGLAS J.) 18 September 2008 See paragraphs [0001]-[0021]; and figures 1-3.	1-12, 14-15
Y		13
Y	US 4614346 A (ITO, LEONARD N.) 30 September 1986 See column 1, line 6 - column 8, line 4; and figures 1-4.	13
X	WO 2008-057726 A2 (SCHLUMBERGER CANADA LIMITED et al.) 15 May 2008 See page 1, line 1 - page 9, line 5; and figures 1-8.	1-12, 14-15
Y		13
Y	US 2011-0036597 A1 (CORRE et al.) 17 February 2011 See paragraphs [0001]-[0040]; and figures 1-7.	13
X	US 2830540 A (VINCENT, RENIC P.) 15 April 1958 See column 1, line 15 - column 6, line 4; and figures 1-4.	1-2, 5-7, 10-12 , 14-15

 Further documents are listed in the continuation of Box C. See patent family annex.

* Special categories of cited documents:

"A" document defining the general state of the art which is not considered to be of particular relevance

"E" earlier application or patent but published on or after the international filing date

"L" document which may throw doubts on priority claim(s) or which is cited to establish the publication date of another citation or other special reason (as specified)

"O" document referring to an oral disclosure, use, exhibition or other means

"P" document published prior to the international filing date but later than the priority date claimed

"T" later document published after the international filing date or priority date and not in conflict with the application but cited to understand the principle or theory underlying the invention

"X" document of particular relevance; the claimed invention cannot be considered novel or cannot be considered to involve an inventive step when the document is taken alone

"Y" document of particular relevance; the claimed invention cannot be considered to involve an inventive step when the document is combined with one or more other such documents, such combination being obvious to a person skilled in the art

"&" document member of the same patent family

Date of the actual completion of the international search

24 March 2017 (24.03.2017)

Date of mailing of the international search report

27 March 2017 (27.03.2017)

Name and mailing address of the ISA/KR

International Application Division

Korean Intellectual Property Office

189 Cheongsa-ro, Seo-gu, Daejeon, 35208, Republic of Korea

Facsimile No. +82-42-481-8578

Authorized officer

KIM, Jin Ho

Telephone No. +82-42-481-8699



INTERNATIONAL SEARCH REPORT

Information on patent family members

International application No.

PCT/US2016/065701

Patent document cited in search report	Publication date	Patent family member(s)	Publication date
US 2008-0223571 A1	18/09/2008	US 7766089 B2 WO 2008-115607 A1	03/08/2010 25/09/2008
US 4614346 A	30/09/1986	EP 0089146 A2 EP 0089146 A3 EP 0089146 B1 EP 0264973 A2 EP 0264973 A3 EP 0264973 B1 JP 58-207479 A JP 62-020356 B2	21/09/1983 10/04/1985 25/01/1989 27/04/1988 25/01/1989 11/12/1991 02/12/1983 06/05/1987
WO 2008-057726 A2	15/05/2008	US 2008-0099209 A1 US 7712541 B2 WO 2008-057726 A3	01/05/2008 11/05/2010 27/11/2008
US 2011-0036597 A1	17/02/2011	AU 2010-283455 A1 AU 2010-283455 B2 MX 2012001815 A US 8336181 B2 WO 2011-018765 A2 WO 2011-018765 A3	08/03/2012 10/12/2015 01/06/2012 25/12/2012 17/02/2011 16/06/2011
US 2830540 A	15/04/1958	None	