

⑫

EUROPEAN PATENT SPECIFICATION

④⑤ Date of publication of the patent specification:
08.08.90

⑤① Int. Cl.⁵: **D05B 1/20, D05B 65/00**

②① Application number: **86105888.1**

②② Date of filing: **29.04.86**

⑤④ **Overlock machine.**

④③ Date of publication of application:
04.11.87 Bulletin 87/45

⑦③ Proprietor: **Jaguar Co., Ltd.,
6-8 Satahigashi-machi 2-chome, Moriguchi-shi,
Osaka-fu(JP)**

④⑤ Publication of the grant of the patent:
08.08.90 Bulletin 90/32

⑦② Inventor: **Koshinaka, Osamu, 5-5, Komyodai 2-chome,
Izumi-shi Osaka(JP)**

④④ Designated Contracting States:
CH DE FR GB LI NL SE

⑦④ Representative: **Glawe, Delfs, Moll & Partner
Patentanwälte,
Rothenbaumchaussee 58 Postfach 2570,
D-2000 Hamburg 13(DE)**

⑤⑥ References cited:
**FR-A- 593 372
US-A- 2 636 462**

EP 0 243 519 B1

Note: Within nine months from the publication of the mention of the grant of the European patent, any person may give notice to the European Patent Office of opposition to the European patent granted. Notice of opposition shall be filed in a written reasoned statement. It shall not be deemed to have been filed until the opposition fee has been paid (Art. 99(1) European patent convention).

Description

The present invention relates to an overlock machine comprising a bed frame, a fixed knife, a movable knife cooperating with said fixed knife to cut the edge of a cloth, a support member adapted to be coupled to a moving part of the machine for supporting said movable knife, and a lower looper provided in rear of said fixed knife and said movable knife.

Figs. 9 and 10 show two prior art overlock machines.

It comprises a bed frame 1 and a bed 2. (Fig. 9) The bed is formed with an opening 4 covered by a throat plate 3 which can be opened. A fixed knife 5 is mounted on a left side wall 6 of the bed frame 1. An elevatable rod 8 is elevatably mounted on guides 9 and 10. A movable knife 11 is fixed to the top end of the elevatable rod 8. A blade 12 on the fixed knife 5 cooperates with a blade 13 on the movable knife 11 to cut the edge of a cloth evenly.

The guides 9, 10 have shafts 14, 15, respectively, which are mounted on the left side wall 6 of the bed frame 1 so as to be retractable. The guide 9 is biased leftwardly by a spring to press the movable knife 11 against the right side of the fixed knife 5. A roller 17 is coupled to a block 16 fixedly mounted on the elevatable rod 8. A forked lever 18 coupled to a moving part of the machine engages the roller 17, so that the elevatable rod 8 will move up and down as the machine is operated.

In another prior art overlock machine shown in Fig. 10, the fixed knife 5 is fixed to a fitting 20 provided under the bed 2. The movable knife 11 is fixed to one end of a shaft 24 turnably and slidably mounted on a boss 23 which is provided at a front end of a swivel arm 22 having its rear portion mounted on a machine body 21 on the bed 2. As shown in Figs. 7 and 8, a spring 25 in the boss 23 urges the movable knife 11 leftwardly to press it against the righthand side face of the fixed knife 5.

The shaft 24 has a pin 28 extending radially and the boss 23 is formed with a notch 29 to receive the pin 28. When the pin 28 is received in the notch 29 as shown in Fig. 7, the movable knife 11 extends downwardly and is pressed by the resilience of the spring 25 against the fixed knife 5. When a knob 30 at the righthand end of the shaft 24 is operated to, pull the shaft 24 rightwardly to disengage the pin 28 from the notch 29 and is turned, the movable knife 11 extends forwardly with the pin 28 butting on the right side of the boss 23, as shown in Fig. 8.

In either of two prior art overlock machines, a lower looper 32 is fixed to the top of a swivel lever 34 mounted on a shaft 33 projecting from the bed frame 1. As shown in Fig. 11, the lower looper 32 is formed with a thread hole 35 at its lefthand end viewing from the operator side. The thread is passed through the hole 35, in and along a thread groove 36, and into a thread hole 37 at the other end of the looper 32.

As shown in Figs. 9 and 10 with dotted lines, the lefthand end of the bed frame 1 is comprised of an auxiliary bed 40 which can be opened. In order to pass a thread through the lower looper 32, a front cover (not shown) is firstly opened and the auxiliary

bed 40 is then opened. On the other hand, the thread from a bobbin (not shown) is passed through a thread tension adjusting assembly and a thread guide (both not shown), through a thread guide 41, under the fixed knife 5 and the throat plate 3, or through an opening 42 in the left side wall 6 of the bed frame 1, and pulled out in rear of the lower looper 32. The thread is then passed through the hole 35 of the lower looper 32, guided in the groove 36, and passed through the hole 37 at tip of the lower looper.

As described above, the setting of a thread through the lower looper 32 is very troublesome. In addition, the fixed knife 5, the parts for securing the fixed knife, the bed frame for supporting it, and the bed portion supporting the throat plate 3 and extending forwardly obstruct the sight of the operator to the lower looper 32 and the access of his fingers to it. This makes the thread setting on the lower looper very troublesome and time-consuming.

From US-PS 2 636 462 a sewing machine is known with similar problems. A lower looper 40 is secured to a shaft like rod 42 projecting from the vertical wall 14 of the main body. Only the work support 16 and a cover member 20 are movable around pivot pins 18, 19. Thus, in this prior art sewing machine the throat plate 23a and the mechanism mounted on the main body also obstruct the sight of the operator to the lower looper 40 and the access of his fingers thereto.

An object of the present invention is to provide an overlock machine which obviates the abovesaid shortcomings.

In accordance with the present invention, the parts and members obstructing the work for setting a thread through the lower looper, which are carried by the movable portion of the bed frame, are adapted to be moved to an inoperative position. Only the fixed knife (in the second embodiment), or both the fixed knife and the movable knife (in the first embodiment) are moved from the front of the lower looper to allow the sight of, and access to, the lower looper. Thus, the operator is given a clear sight of the lower looper and an easy access of his fingers to it. This facilitates the thread setting very much.

Other objects and features of the present invention will become apparent from the following description taken with reference to the accompanying drawings, in which:

Fig. 1 is a perspective view of the first embodiment with the movable portion of the bed frame closed;

Fig. 2 is a perspective view thereof with the movable portion opened;

Fig. 3 is a partially sectional rear view of the movable portion of the first embodiment;

Fig. 4 is a side view showing the driving mechanism for the movable knife in the first embodiment;

Fig. 5 is a perspective view of the second embodiment with the movable portion of the bed frame closed;

Fig. 6 is a perspective view thereof with the movable portion opened;

Figs. 7 and 8 are enlarged plan views showing how the movable shaft is mounted;

Figs. 9 and 10 are perspective views of the two prior art overlock machines; and

Fig. 11 is a partially cutaway front view of the lower looper.

The first embodiment shown in Figs. 1 - 4 provides an improvement of the prior art overlock machine shown in Fig. 9. Both the fixed knife 5 and the movable knife 11 are mounted on a movable portion 45 of a bed frame 1. The movable portion is mounted so as to be pivotable around a shaft 46 shown in Fig. 3. A fixed knife 5 is bolted to a mounting surface 44 of the movable portion 45.

A movable knife 11 is mounted on an elevatable rod 8 (Fig. 3). A shaft 14 of a guide 9 on the elevatable rod 8 is retractably mounted in a mounting portion 48 in the movable portion 45. The shaft 14 is biased by a spring 49 mounted thereon in a hole formed in the shaft at its rear end and supported by a spring support 50 secured to the rear end of the shaft 14 in such a direction as to press the movable knife 11 against the fixed knife 5.

A forked lever 18 has its middle portion supported by a shaft 51 and its rear end coupled to a link 53 which is moved up and down by a lower shaft 52 of the machine through an eccentric (Fig. 4). The forked lever 18 has its front portion forked to receive a roller 17 disposed in the movable portion 45.

A hook 55 (Figs. 2 - 4) is secured to the inner end of a transverse shaft 57 turnably mounted in the movable portion 45. A knob 58 is secured to the outer end of the transverse shaft 57. The hook 55 is adapted to engage an engagement piece 60 fixed in the bed frame 1 (Fig. 2). When the movable portion 45 is closed, the hook 55 engages the engagement piece 60 by the action of a spring. By operating the knob 58, the hook 55 can be disengaged from the engagement piece 60.

In the first embodiment, with the movable portion 45 closed, the hook 55 engages the engagement piece 60 and the forked lever 18 engages the roller 17 on the elevatable rod 8. Thus, as the machine operates, the forked lever 18 will pivot up and down, so that the elevatable rod 8 and thus the movable knife 11 will move up and down.

When passing a thread through the lower looper 32, the knob 58 is operated to disengage the hook 55 from the engagement piece 60. Now, the movable portion 45 can be swung to its inoperative position as shown in Fig. 2. This allows the sight of and access to the lower looper 32. Setting a thread on it is now very easy.

The second embodiment shown in Figs. 5 and 6 provides an improvement of the prior art overlock machine shown in Fig. 10. The movable knife 11 is supported in the same manner as in the prior art overlock machine, as shown in Figs. 7 and 8 and described before. Only the fixed knife 5 is secured to a mounting plate 47 secured to the movable portion 45. In the second embodiment, too, a hook 55 and a knob 58 are fixedly mounted on a transverse shaft 57 rotatably mounted on the movable portion 45, as in the first embodiment. The hook 55 is adapted to engage an engagement piece 60 secured to the bed frame 1.

In the second embodiment, too, with the movable portion 45 closed, the hook 55 engages the engagement piece 60. With the movable knife 11 extending downwardly and the pin 28 engaged in the notch 29 in the boss 23 as shown in Fig. 7, the movable knife 11 is pressed against the fixed knife 5, as shown in Fig. 5, and moves up and down, as the machine operates, to cut the cloth edge evenly.

In order to set a thread through the lower looper 32, the shaft 24 is pulled with the knob 30 against the bias of the spring 25 to disengage the pin 28 from the notch 29 and is turned to the position shown in Fig. 8 where the movable knife 11 faces to the front.

When the lower knob 58 is operated to disengage the hook from the engagement piece 60 and the movable portion 34 is swung open to its inoperative position as shown in Fig. 6, there is no obstruction to the sight of and access to the lower looper 32, as in the first embodiment. Now, a thread can be easily set through the lower looper.

Although in the preferred embodiments, the movable portion 45 is adapted to be pivoted sidewise, it may be adapted to be pivoted downwardly to be pulled out, or to be moved to its inoperative position in any other way.

Although in the embodiments a forked lever 18 is coupled to the machine body and the roller 17 is used to move the movable knife up and down, a roller may be used instead of the forked lever and a forked lever may be used instead of the roller.

Claims

35 An overlock machine comprising a bed frame, a fixed knife, a movable knife cooperating with said fixed knife to cut the edge of a cloth, a support member adapted to be coupled to a moving part of the machine for supporting said movable knife, and a lower looper provided in rear of said fixed knife and said movable knife, characterised in that said bed frame (1) has a movable portion (45) adapted to be moved to an inoperative position so as not to obstruct the sight of and the access to said lower looper (32) for the setting of a thread through said lower (32), either said fixed knife (5) only or both said fixed knife (5) and said movable knife (11) being mounted on said movable portion (45) of said bed frame (1), said movable portion (45) being provided with engagement means (55, 57, 58, 60) for releasably engaging said movable portion (45) with body of said bed frame (1).

Patentansprüche

55 Übernahmemaschine mit einem Bettkörper, einem feststehenden Messer, einem bewegbaren Messer, das mit dem feststehenden Messer kooperiert, um den Rand eines Kleidungsstücks abzuschneiden, einem Tragteil, das so ausgebildet ist, daß es mit einem Bewegungsteil der Maschine gekoppelt werden kann, um das bewegbare Messer zu tragen, und einem unteren Greifer, der hinter dem feststehenden Messer und dem bewegbaren Messer vorgesehen ist, dadurch gekennzeichnet, daß

der Bettkörper (1) einen bewegbaren Bereich (45) aufweist, der so ausgebildet ist, daß er so in eine Ruhestellung bewegt werden kann, daß er die Sicht und den Zugriff auf den unteren Greifer (32) zum Führen eines Fadens durch den unteren Greifer (32) nicht behindert, wobei entweder nur das feststehende Messer (5) oder sowohl das feststehende Messer (5) als auch das bewegbare Messer (11) auf dem bewegbaren Bereich (45) des Bettkörpers (1) angebracht sind, wobei der bewegbare Bereich (45) mit einer Einrasteinrichtung (55, 57, 58, 60) zum lösbaren Einrasten des bewegbaren Bereichs (45) mit dem Bettkörper (1) versehen ist.

Revendications

Machine à coudre à surjet comportant un bâti, un couteau fixe, un couteau mobile coopérant avec le dit couteau fixe de façon à couper le bord d'un vêtement, un élément de support prévu pour être couplé à une partie mobile de la machine afin de supporter le dit couteau mobile, et un guide-fil inférieur prévu, à l'arrière du dit couteau fixe et du dit couteau mobile, caractérisée en ce que le dit bâti (1) possède une partie mobile (45) prévue pour être déplacée vers une position inactive de façon à ne pas boucher la vue sur et l'accès au dit guide-fil inférieur (32) pour la mise en place d'un fil dans le dit guide-fil inférieur (32), soit le dit couteau fixe (5) seulement, soit le dit couteau fixe (5) et le dit couteau mobile (11) à la fois étant montés sur la dite partie mobile (45) du dit bâti (1), la dite partie mobile (45) étant pourvue de moyens d'engagement (55, 57, 58, 60) pour engager de façon libérable la dite partie mobile (45) avec le corps du dit bâti (1).

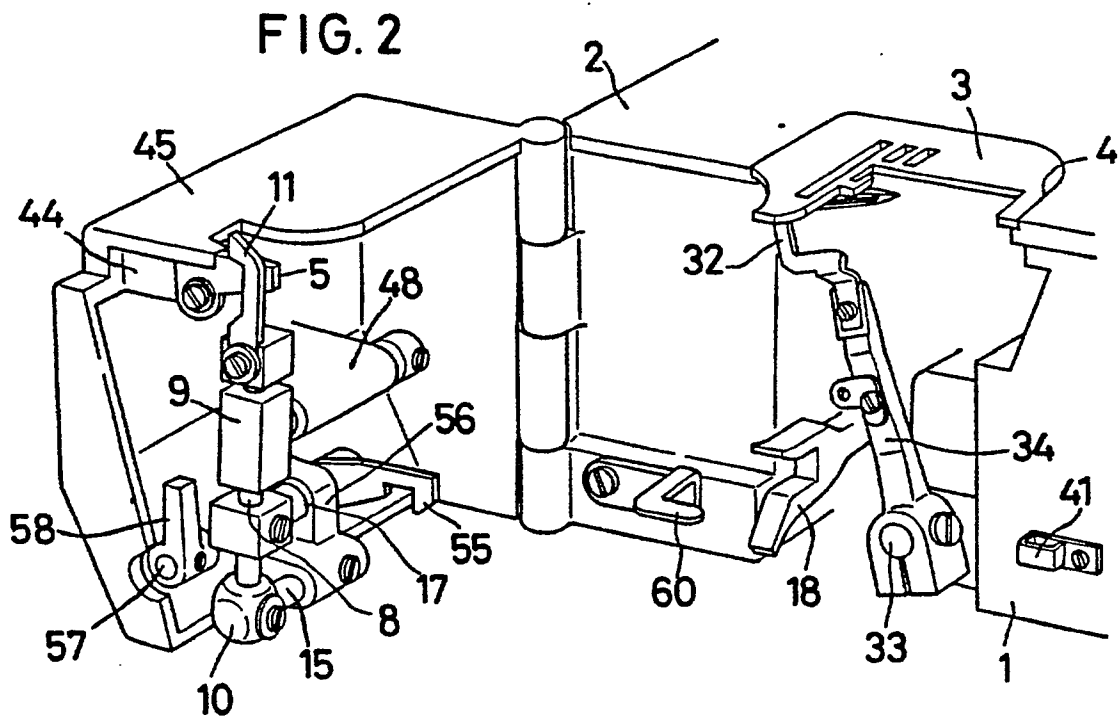
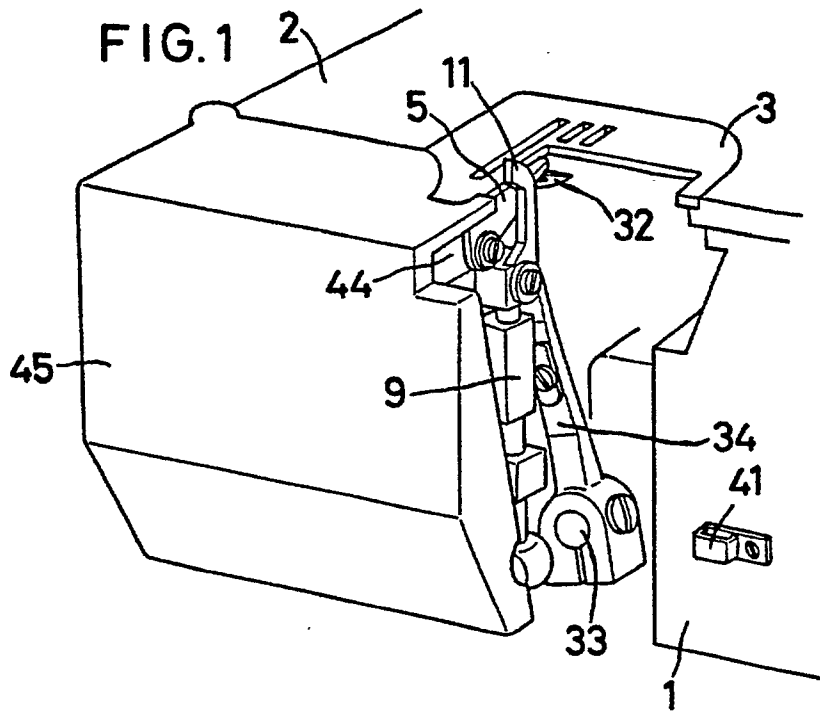

FIG. 3

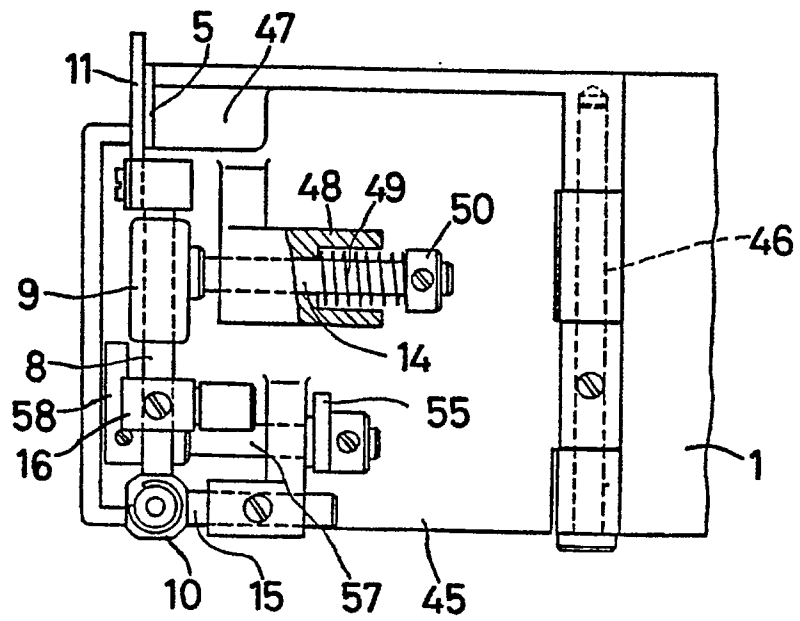

FIG. 4

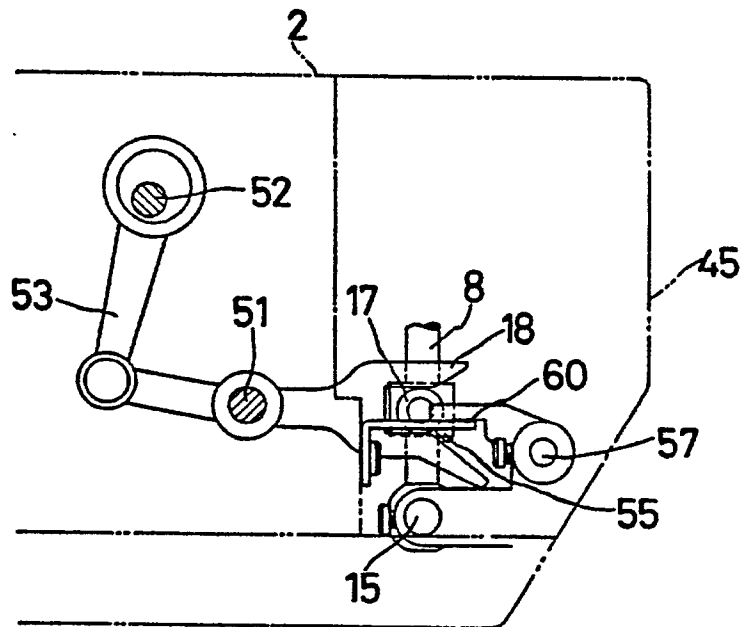

FIG. 5

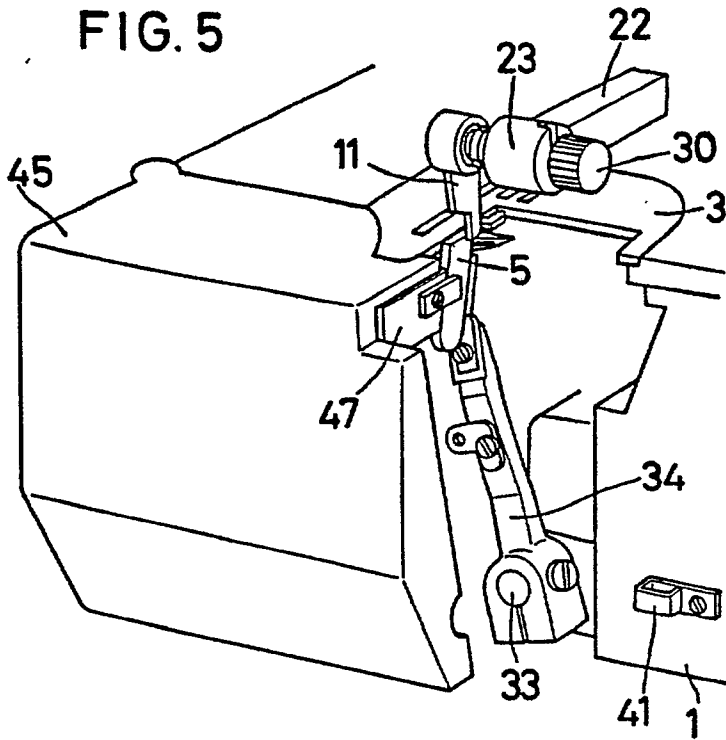

FIG. 6

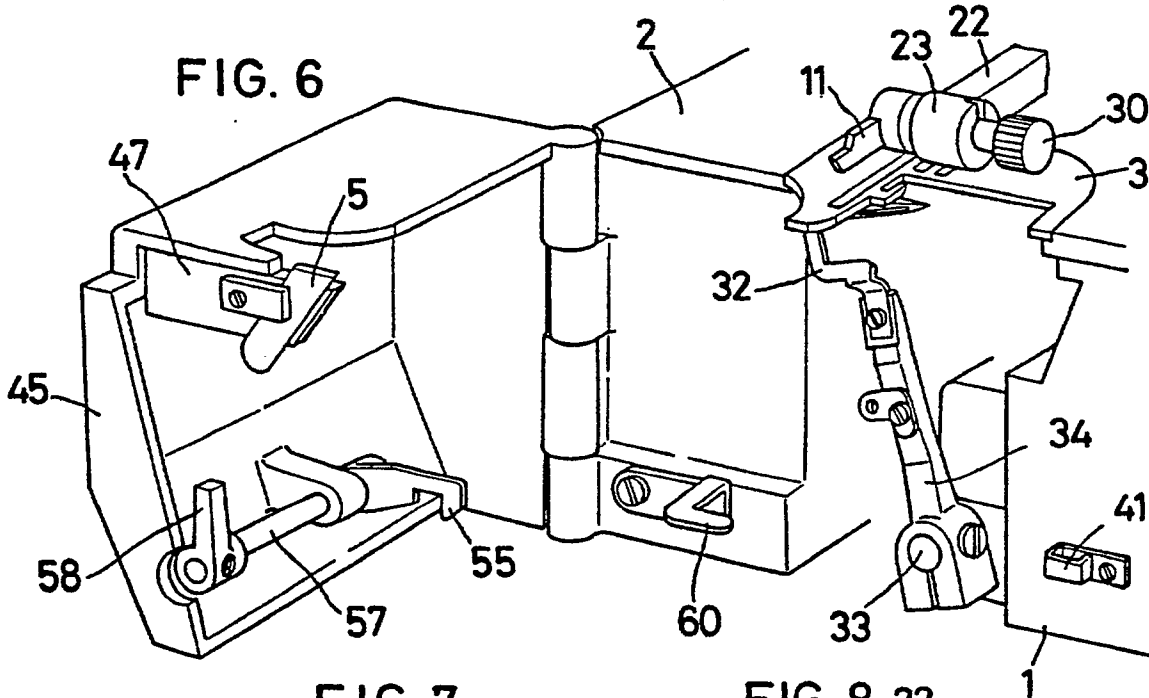

FIG. 7

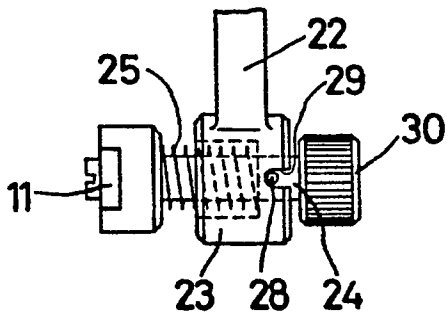

FIG. 8

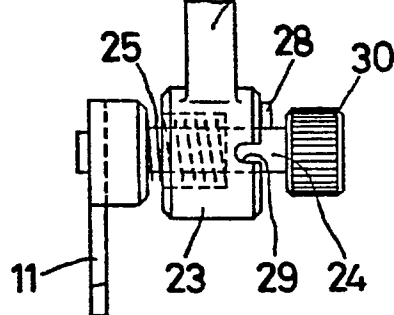

FIG. 9 PRIOR ART

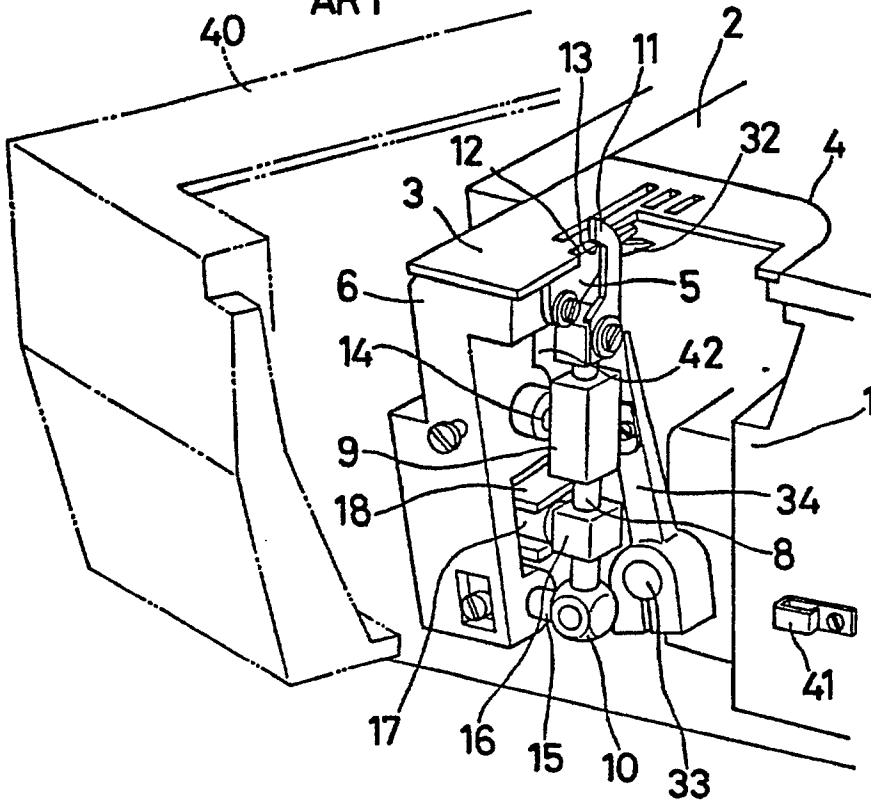

FIG. 10 PRIOR ART

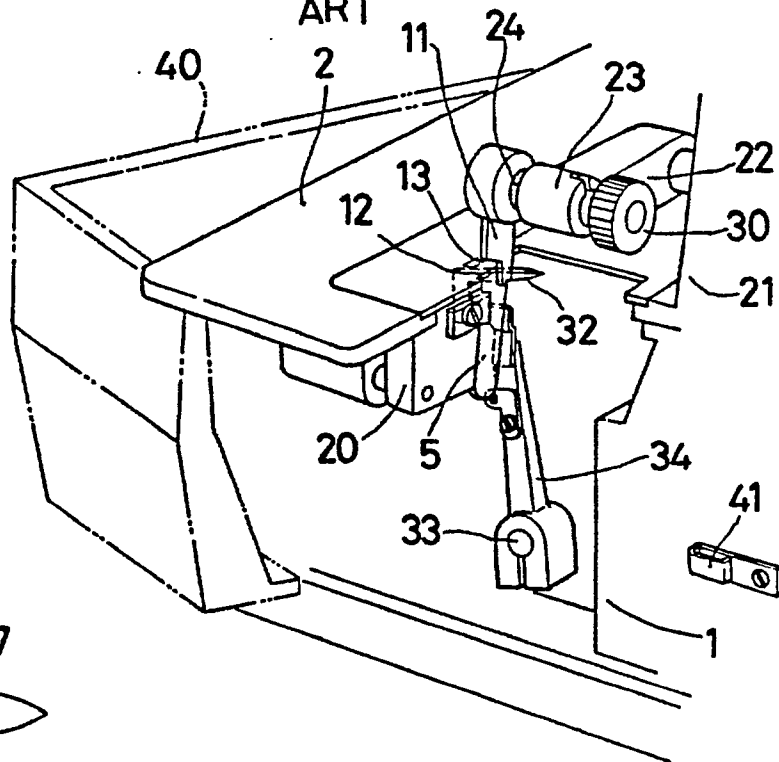

FIG. 11

