

M. W. KIDDER.
Gas-Pressure Regulator.

No. 209,407.

Patented Oct. 29, 1878.

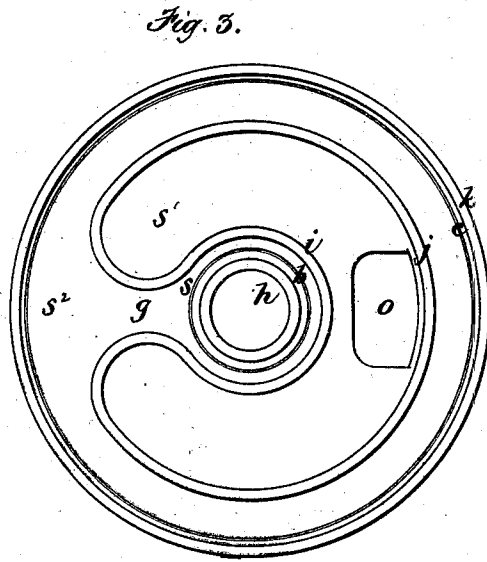
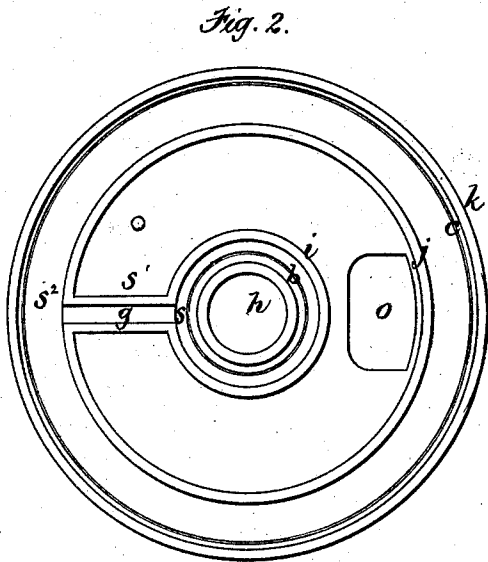
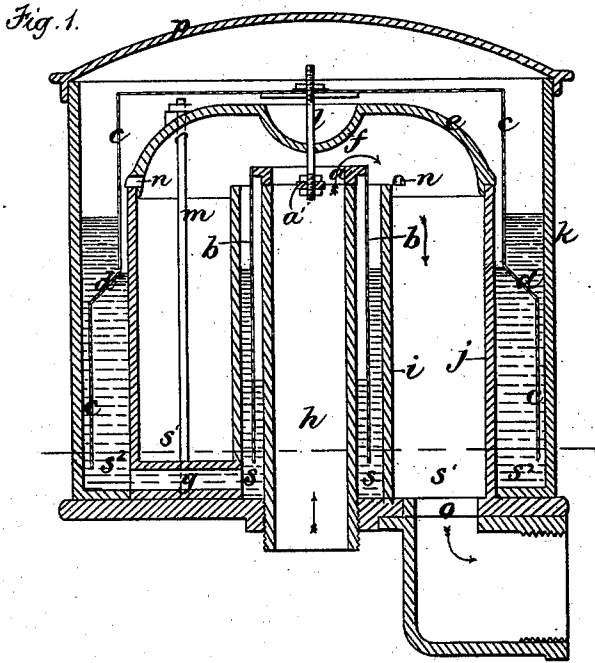

Witnesses.

R. B. Underwood
M. F. Emerson

Inventor
M. W. Kidder
by Wright & Brown
Atty.

UNITED STATES PATENT OFFICE.

MOSES W. KIDDER, OF BOSTON, ASSIGNOR TO PERSON NOYES, OF LOWELL,
MASSACHUSETTS.

IMPROVEMENT IN GAS-PRESSURE REGULATORS.

Specification forming part of Letters Patent No. **209,407**, dated October 29, 1878; application filed
October 11, 1877.

To all whom it may concern:

Be it known that I, MOSES W. KIDDER, of Boston, in the county of Suffolk and State of Massachusetts, have invented certain Improvements in Gas-Pressure Regulators, of which the following is a specification:

In the accompanying drawings, forming a part of this specification, Figure 1 represents a vertical section of my invention. Fig. 2 represents a horizontal section of the same, and Fig. 3 represents a horizontal section of a modification.

Similar letters of reference refer to like parts in all the figures.

The object of this invention is to so improve the gas-pressure regulator as to obviate certain defects which have become apparent in preceding devices.

My said invention includes, as a new feature in the construction of gas-pressure regulators, the upwardly-closing annular valve or gate *a*, with its dependent telescopic tube *b*, whereby all disturbance from the action of the valve due to variations of pressure in the street-mains or from position of the valve is wholly obviated.

My said invention also includes, as new in the construction of gas-pressure regulators, the inverted cup *c*, when made with a conoidal band, *d*, for the purpose of furnishing an increasing area for the supporting action of the gas as the cup rises from the liquid packing, and a decreasing area as it sinks into the same, the purpose of this being proportional compensation for friction in the distributing-pipes after the gas has passed the regulator; the vertical motion of the gate determining the altitude of this band, and the difference of pressure-area desired the horizontal width of the same approximately.

This invention further includes, in the construction of gas-pressure regulators, the fixed diaphragm *e*, supporting the hemispheroidal seat *f* for the gate *a*, and arresting the impulse of the gas as it flows through the gate, thus preventing its direct impact upon the inverted cup *c* and its consequent disturbance.

This invention further includes a communi-

cating passage, *g*, from the annular chamber *s* to the annular chamber *s*², as shown, all of which I will now proceed to describe.

In carrying out my invention I construct the gas-pressure regulator chiefly of cast-iron, and provide a central pipe, *h*, for the introduction of gas. This pipe rises about four inches from the floor of the regulator, through which it passes far enough to connect it with the meter. Concentric with this pipe is a larger one, *i*, rising to about the same height. The concentric chamber *s* between these two pipes is provided for the reception and sealing of the telescopic tube *b*. I also provide a concentric inner wall, *j*, of the same height from the floor as the center pipe, also an outer wall, *k*, about seven inches high. Between these two is another annular concentric chamber, *s*², for the reception and sealing of the lower edge of the inverted cup *c*; and between the wall *j* and tube *i* is a concentric annular chamber, *s*¹, for the passage of gas through the regulator from the inlet to the outlet thereof.

The concentric annular chambers *s* and *s*² communicate through a passage, *g*, formed by extending a tube from one to the other, as shown in Fig. 1, or by cutting out a section of the inner wall, *j*, and larger pipe *i*, and connecting them, as shown in Fig. 3. Rising from the inner wall, and covering the central portion of the apparatus, is a fixed diaphragm, *e*, of cast-iron, upon the under surface of which is a hemispheroidal seat, *f*, against which the annular gate *a* closes. Through the center of this diaphragm passes the rod *l*, to connect the gate *a* with the inverted cup *c*. A bolt, *m*, confines the diaphragm in place, and certain orifices *n* in the edge allow the gas to pass into the inverted cup.

Below the diaphragm is provided an annular gate, *a*, having a cross-bar, *a'*, and rod *l*, for connecting it with the inverted cup, also a depending telescopic tube, *b*, which dips down into the chamber *s*, between the central pipe, *h*, and the larger one *i*.

Above the diaphragm is the inverted cup or hollow cylinder *c*, made of tin-plate, of a smaller diameter at the top and larger at the bottom.

About half-way from the bottom to the top an intervening conoidal band, *d*, connects the upper and lower parts.

Beneath the floor, and communicating with the chamber *s*¹, is an outlet, *o*, to which the service-pipe is connected, and above all a cover, *p*, is provided to close the top.

The operation of my improved gas-pressure regulator is as follows: The inlet-pipe *h* having been attached to the outlet of the gas-meter, or a pipe leading from the same, and the outlet *o* connected with the burner-supply pipe, the annular chambers *s* *s*², connected through passage *g*, are filled with glycerine, so that the lower end of the telescopic tube *b*, depending from the gate *a*, as well as the lower edge of the inverted cup *c*, are both sealed against the passage of gas below them. The gas, being now admitted, passes upwardly through the central pipe, *h*, and between the annular gate *a* and the hemispheroidal seat *f*. It is then deflected by the diaphragm *e*, the openings *n* in which allow the gas to pass, so as to exercise the same pressure upon the under side of the inverted cup *c* as beneath the diaphragm after it has passed the gate *a*, the result being the forcing upward of the inverted cup *c*; and as the annular gate *a* is connected with the inverted cup by the rod *l*, the gate is carried upward toward the hemispheroidal seat *f* until the gas is shut off so far as to reduce the supporting-pressure below the inverted cup to the same force as that produced by the weight of the inverted cup and its attachments, with whatever weights may be added. Now, as the gas is drawn from the regulator to the burners it necessarily relieves the pressure beneath the inverted cup, which falls just enough to allow the opening of the gate to supply what gas is being drawn through, the pressure always being automatically adjusted to the weight of the inverted cup and its connections, the weight of which, being fixed, would, with the same area of support, always give the same pressure upon every square inch under the inverted cup, regardless of the quantity of gas passing through the regulator; but as the friction of the gas in the pipe increases with the quantity passing, it is desirable to increase proportionally the pressure to compensate for that friction. This is most perfectly accomplished by the varying area

obtained by the conoidal band, so that the proportion of the weight of the inverted cup, its connections, and added weights to the supporting-area upon which the gas-pressure acts is uniformly increased as the inverted cup sinks in the glycerine, and vice versa.

In this manner regulators for street-mains can be so adjusted as to give any desired pressure for a given flow of gas.

I claim as my invention—

1. In a gas-regulator, an upwardly-closing annular valve, *a*, suspended from a floating inverted cup, *c*, and provided with a sealed depending tube, *b*, which surrounds the inlet-pipe of the regulator, combined with a fixed hemispheroidal valve-seat, *f*, intermediate of said cup *c* and valve *a*, substantially as described.

2. In combination with the upwardly-closing valve or gate *a* and its seat *f*, the inverted floating cup *c*, provided with the conoidal band *d*, said band being so arranged relatively to the liquid packing that its under and inner surface will be entirely submerged therein when said valve or gate is open, and raised entirely above said packing when the valve or gate is closed, or nearly so, substantially as and for the purpose specified.

3. In a gas-regulator, the diaphragm *e*, provided with the hemispheroidal seat *f* for the valve, and adapted to arrest the impulse of the gas, as set forth.

4. In a gas-regulator, the combination of the inlet-pipe *h*, annular valve *a*, having depending telescopic tube *b*, inverted cup *c*, connected to said valve, and perforated diaphragm *e*, located between said valve and cup, and provided with valve-seat *f*, as set forth.

5. In a gas-regulator, the combination of the annular connected chambers *s* *s*² and intervening chamber, *s*¹, with the valve *v*, valve-gate *a*, the depending telescopic tube *b*, and the inverted cup *c*, all contained in the casing *k*, as set forth.

In testimony whereof I have signed my name to this specification, in the presence of two subscribing witnesses, this 9th day of October, 1877.

MOSES W. KIDDER.

Witnesses:

C. F. BROWN,
F. A. WILDER.