

J. Sheldon. Sheet 1.5 Sheets.
Hat Blocking Mach.
N^o 103,484. Patented May 31, 1870.

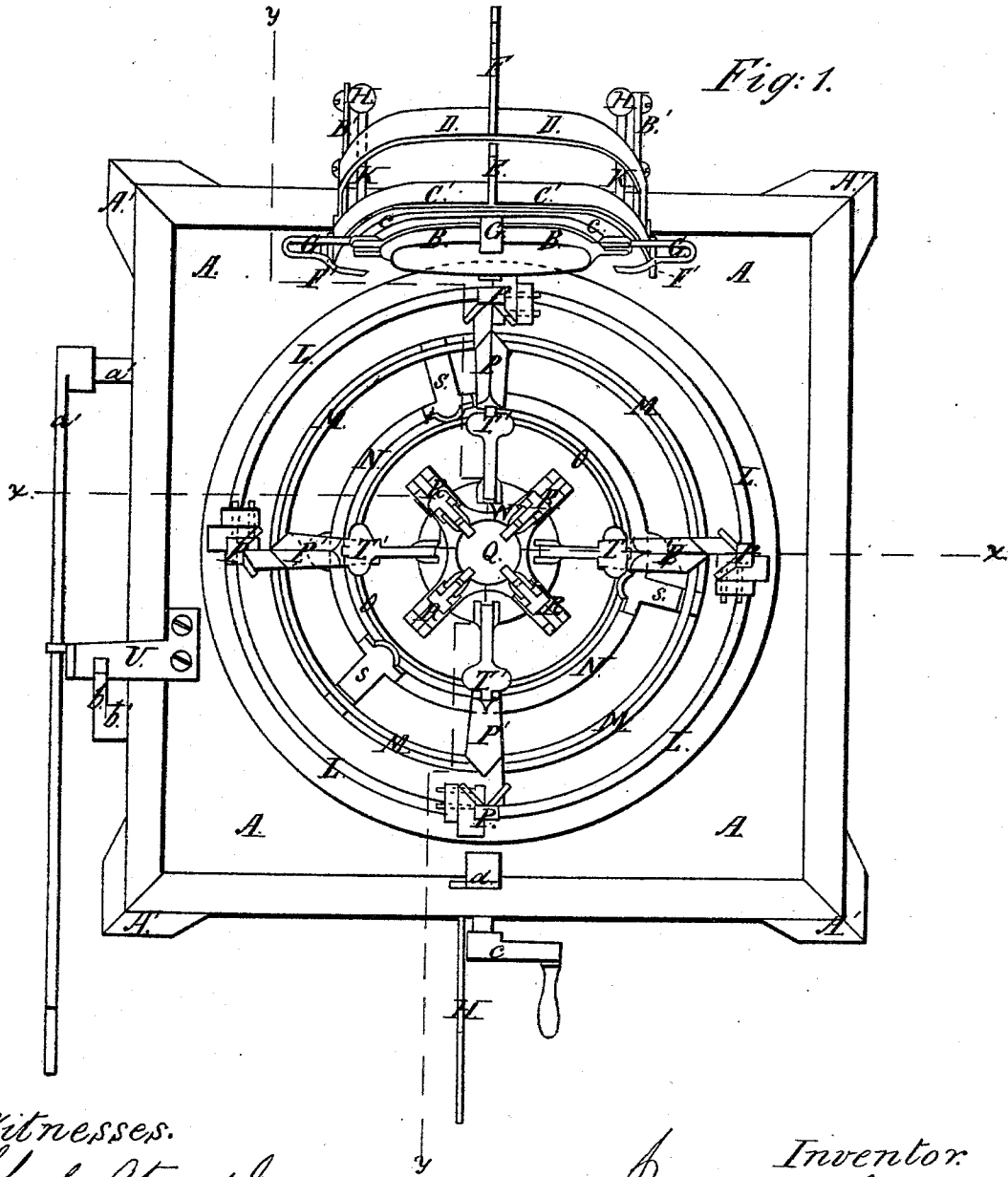

Witnesses.
Charles Atwood Jr.
Geo. H. Collins

Inventor.
Julius Sheldon

J. Sheldon. Sheets 2, 5 Sheets.
Hat Blocking Mach.
N^o 103,787. Patented May 31, 1870.

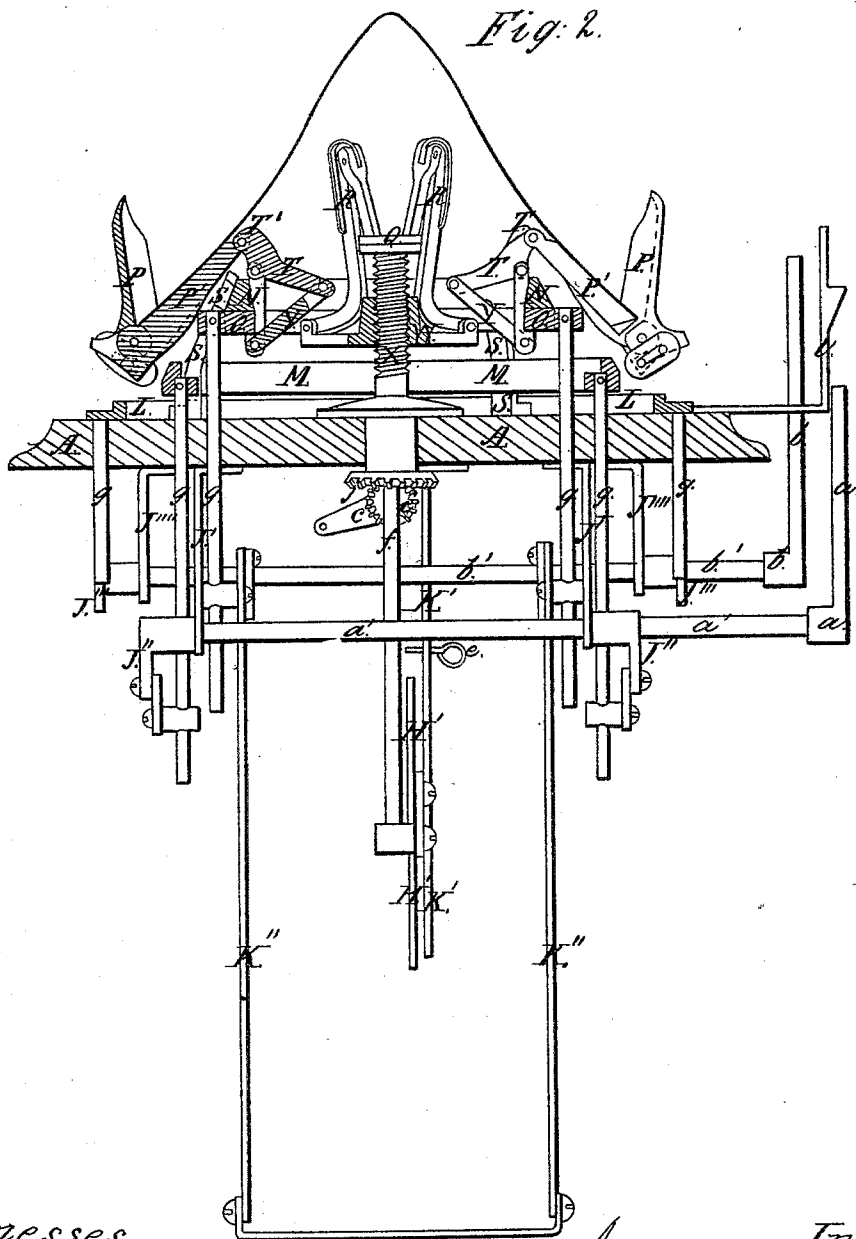

Witnesses.

Charles Ottwood Jr.
Geo. H. Collins.

Inventor.

Jubius Sheldon.

J. Sheldon. *Sheet 3, 5 Sheets.*

Hat Blocking Mach.

N^o 103,787.

Patented May 31, 1870.

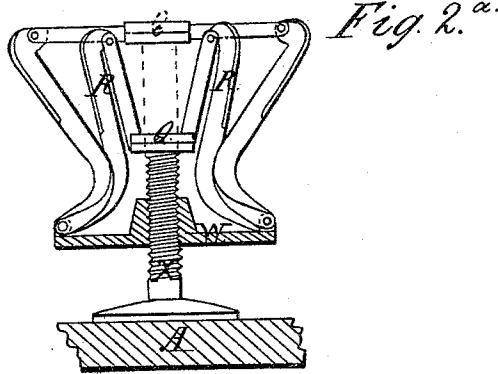

Fig. 2. a.

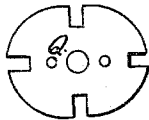

Fig. 2. b.

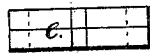

Fig. 5.

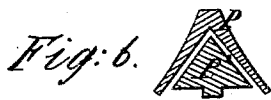
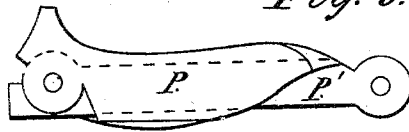

Fig. 6.



Fig. 7.

Witnesses.

*Charles Atwood Jr.
Geo. H. Collins.*

Inventor.

Julius Sheldon.

J. Sheldon. Sheet 4, 5 Sheets.
Hat Blocking Mach.
N^o 103,787. Patented May 31, 1870.

Fig. 3.

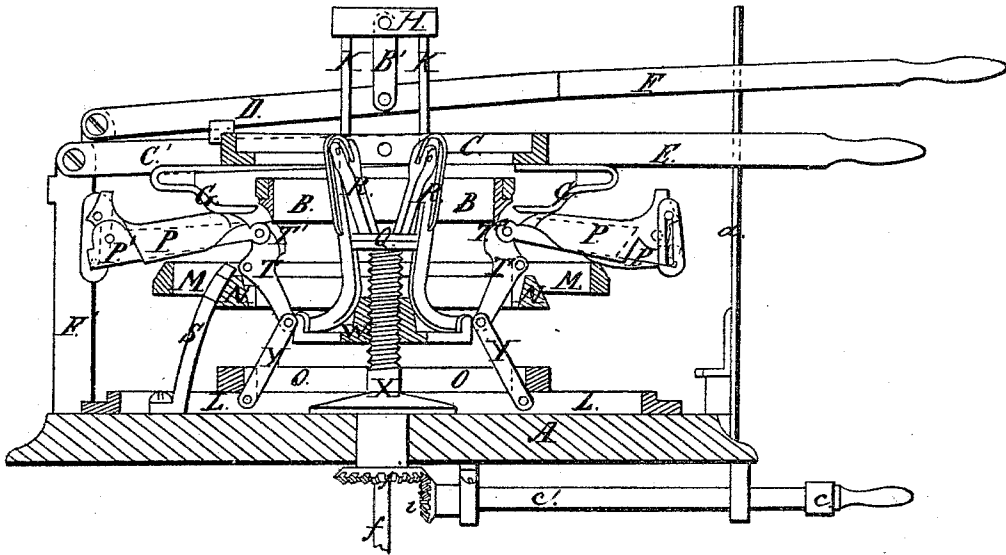
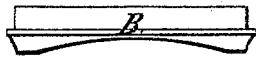

Fig. 3^a



Witnesses.

Charles Atwood Jr
Geo. H. Collins

Inventor.

Julius Sheldon

J. Sheldon. *Sheet 5, 5 Sheets.*

Hat Blocking Mach.

N^o 103,787.

Patented May 31, 1870.

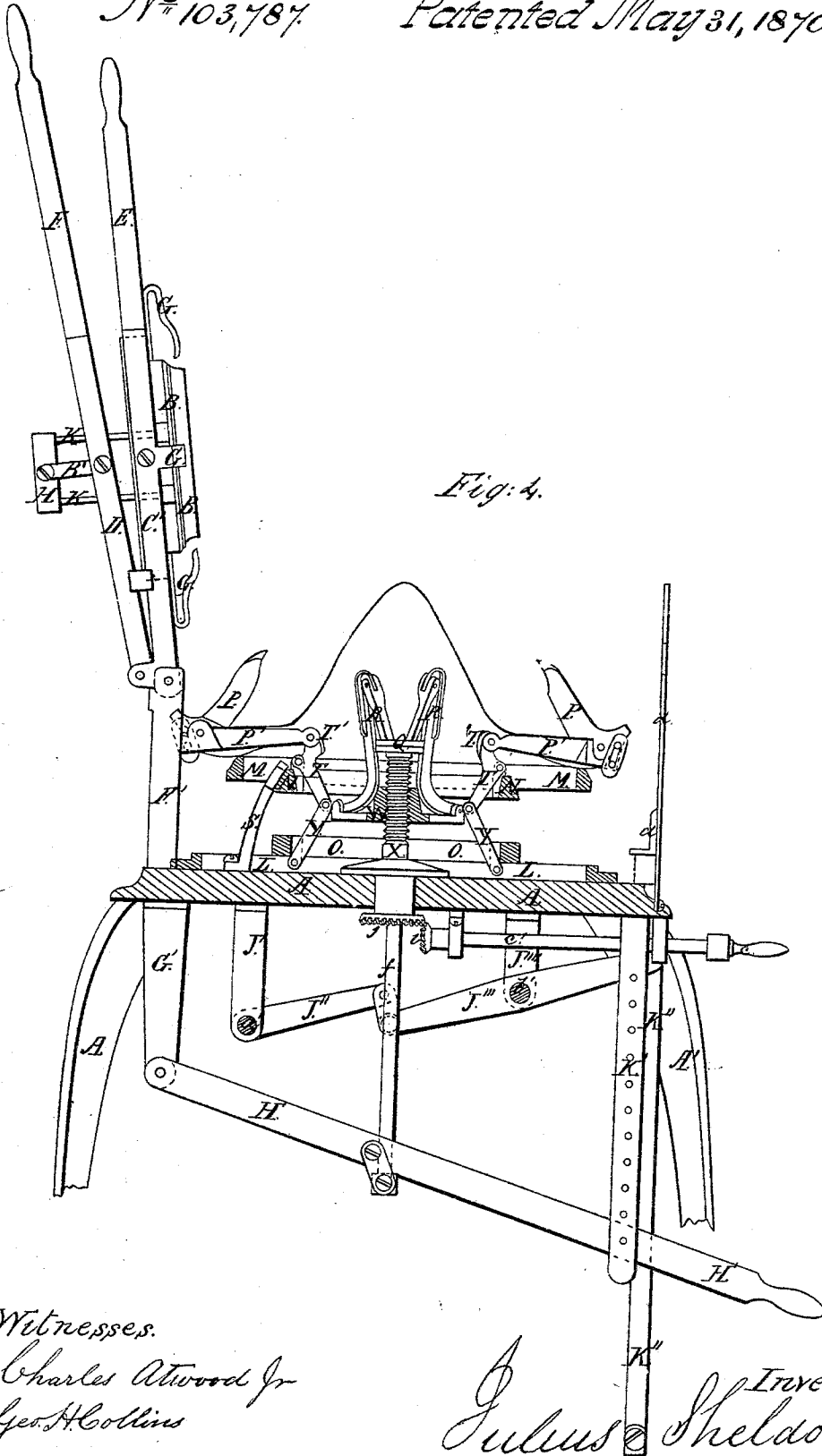

Witnesses.

*Charles Atwood Jr
Geo. H. Collins*

*Inventor.
Julius Sheldon.*

United States Patent Office.

JULIUS SHELDON, OF NEW YORK, N. Y.

Letters Patent No. 103,787, dated May 31, 1870.

IMPROVEMENT IN HAT-BLOCKING MACHINES.

The Schedule referred to in these Letters Patent and making part of the same

To all whom it may concern:

Be it known that I, JULIUS SHELDON, of the city, county, and State of New York, have invented certain new and useful Improvements in Hat-Blocking Machines; and I hereby declare that the following is a full, clear, and exact description thereof, reference being had to the accompanying drawings making part of this specification.

In hat-blocking machines known to me prior to my present invention, there existed a want of means to thoroughly and properly break the band of the hat, and the means of giving proper and necessary draft or stretch upon the rim, in a manner that would do it evenly, and not create in it unevenness, which is the case when corrugated surfaces alone are used for that purpose, as well as a deficiency in means of shaping properly the tips and giving curve to the bottom of the hat-body.

In my invention, I have produced clamps or pincers, so shaped as to hold, and, at the same time, stretch the hat-rim proportionally, as it increases in width, giving the greater stretch to the outer edge, and so mounting and arranging them that they can be elevated outwardly, and, when at their proper elevation, be moved or thrown outward from the body of the hat, drawing out the rim, and holding it thus, while the band ring is operated and thrown down around the body of the cone, below the level of the extended rim, carrying the hat-body down and properly stretching and breaking the band, and producing that indispensable result called "pumping," by hat-blockers, when it is done by hand; and I so form this band-ring that I give either a straight or curved bottom to the hat, as I desire. I also so shape the tip-piece that I make the tip of the hat circular or curved, as desired.

To enable others skilled in the art to understand and make my invention, I will describe its construction and operation; the same letters in all the figures refer to corresponding parts of the machine.

Figure 1 is a top view of the machine with the band-ring thrown up ready to receive the cone.

Figure 2 is a cross-sectional elevation through $x x$, fig. 1, looking from behind the machine.

Figure 2^a is a detached view of the tip-stretcher.

Figure 2^b are detached views of the oval-shape tip-piece.

Figure 3 is a cross-section at right angles to $x x$, fig. 1.

Figure 3^a is a side view of curved bottom band-ring.

Figure 4 is a sectional elevation through $y y$, fig. 1.

Figure 5 is a side view of the clamp or pincers when closed.

Figures 6 and 7 are cut sections of the clamp, showing the angular and circular-shaped holding surfaces. In the drawings—

Letter A is the table or bed-plate of the machine.

A', the legs.

B, the movable band-rim.

B', the connection uniting frame D with cross-heads H H.

C, the ring which sustains ring B, and to which the springs G G are attached.

C' is the lever-frame, supporting ring C.

D is the lever-frame operating the band-rim B, by means of connection B' and connecting-rods K K.

E and F are levers or handles to frames D and C.

G G are springs attached to ring C, which close the pincers upon the cone and hold them together.

H H, the cross-heads, between connecting-rods K K, connected with and operating band-rim B.

H' is the lever which raises the center or tip-piece Q, expanding lever-arms R R.

K' is the rod below the table, which holds lever H', and to which it is fastened by pin e , to keep the tip extended, as desired.

L is the circular frame, which is operated by lever a , and closes the pincers upon the cone.

M is the ring-frame, which elevates the clamps horizontally, and is operated by lever b and kept in position by latch U.

N is a stationary frame, supported by standards S S and levers T y hinged upon it, and to which the clamps P P' are pivoted.

T' is a shield, which protects the joints of levers T and clamps P P' from contact with cone.

O is the circular frame, operating the double-jointed levers T y , and to which y is hinged.

T and y are double-jointed levers, which are connected with clamps P P', and which operate and control their movements in connection with ring O and operated by lever K'.

Q is the center or tip-piece, to which lever-arms R R are hinged, and which, by its shape, either oval or circular, give shape to the hat-tip when blocked, the arms R R being expanded by means of lever H', give the stretch to the crown.

P and P' are the two jaws which form the clamp or pincers, which hold, and, by their operation, stretch the hat-rim.

W is the frame, supporting lever-arms R R, through which a hollow screw passes, which raises or lowers it to suit the height of crown desired, and through this hollow screw, rod f passes, which is connected to the tip or center-piece, and which is operated by lever H'.

G' is the support, to which lever H' is hinged

F' is the standard, to which the ring-band B and its supports are hinged.

J''' J'''' are the levers operated by K'', to push out the clamps.

c and *c'* show the crank and connection which operate the gears *i j*, and raises or lowers the frame which stretches the tip of the hat.

a and *a'* is the lever which operates ring *L*, closing the clamps upon the cone after it is in the machine.

b, the lever, which elevates the ring *M*, and holds the clamps in horizontal position.

d, the latch, which fastens lever *E* in position while the band-ring *B* is worked to break the band.

g g g are rods, connecting the levers with the frames above the table.

I will now proceed to describe the operation of my machine.

The machine being open, as shown in fig. 4, the cone is put upon the lever-arms *R R*, the lower edge laying upon the inner surfaces of clamps *P P'*, when lever *b* is brought forward, thereby raising ring *L*, which closes the clamps upon the cone. The lever is then brought down, bringing over the band *B* and *C* upon the tip, and the springs *G G* closing and holding the jaws of the clamps. Lever *H'* is then raised and fastened in position by means of pin *e*, which stretches the tip into shape. Lever *a* is then raised and fastened upon latch *U*, which raises ring *M*, and brings up the clamps into a horizontal position, and so supports them. The foot is then placed upon the stirrup-lever *K''* and pressure applied sufficient to push out the clamps *P P'* from the center, and, while thus held by the weight upon the stirrup, the right hand seizes the lever *F*, and the process of breaking the band-ring is done by repeat-

edly forcing the band-ring *B* down below the level of the knuckles or shields of the clamps at the same time that the rim is forced out by the pressure upon the stirrup-lever *K''*, producing the effect desired.

Having thus described my invention,

What I claim, and desire to secure by Letters Patent, is—

1. In a hat-blocking machine, double-jointed levers, so mounted and attached as to give centrifugal motion to the clamp, substantially as set forth.

2. In combination with a hat-blocking mechanism, a banding-ring, so arranged as to be capable of a pumping or reciprocating motion.

3. An oval-shaped tip-piece, *Q*, in combination with levers *R R*, for giving an oval shape to the tip of the hat.

4. The combination of clamps *P P'*, levers *T y*, and banding-ring *B*, all operating together in the manner and for the purposes set forth.

5. The combination of the reciprocating banding-ring *B* and clamps *P P'*, operating in the manner and for the purposes set forth.

6. In combination with hat-blocking mechanism, the crank *c*, shaft *c'*, and geared wheels *i* and *j*, for the purpose of adjusting the height of crown to the hat, substantially as shown.

JULIUS SHELDON.

Witnesses:

GEO. H. COLLINS,

W. T. HUNTINGTON.