



(51) International Patent Classification:

B60N 2/427 (2006.01) *B61D 17/00* (2006.01)
B60R 21/00 (2006.01) *B61D 15/06* (2006.01)
B61F 5/24 (2006.01) *B62D 39/00* (2006.01)

(21) International Application Number:

PCT/PL2017/000001

(22) International Filing Date:

12 January 2017 (12.01.2017)

(25) Filing Language:

Polish

(26) Publication Language:

English

(30) Priority Data:

P.415802 15 January 2016 (15.01.2016) PL

(72) Inventors; and

(71) Applicants : JANAS, Wiktoria [PL/PL]; Chwałki 194,
27-600 Sandomierz (PL). JANAS, Marcin [PL/PL];
Chwałki 194, 27-600 Sandomierz (PL).

(81) Designated States (unless otherwise indicated, for every
kind of national protection available): AE, AG, AL, AM,
AO, AT, AU, AZ, BA, BB, BG, BH, BN, BR, BW, BY,
BZ, CA, CH, CL, CN, CO, CR, CU, CZ, DE, DJ, DK, DM,
DO, DZ, EC, EE, EG, ES, FI, GB, GD, GE, GH, GM, GT,

HN, HR, HU, ID, IL, IN, IR, IS, JP, KE, KG, KH, KN,
KP, KR, KW, KZ, LA, LC, LK, LR, LS, LU, LY, MA,
MD, ME, MG, MK, MN, MW, MX, MY, MZ, NA, NG,
NI, NO, NZ, OM, PA, PE, PG, PH, PL, PT, QA, RO, RS,
RU, RW, SA, SC, SD, SE, SG, SK, SL, SM, ST, SV, SY,
TH, TJ, TM, TN, TR, TT, TZ, UA, UG, US, UZ, VC, VN,
ZA, ZM, ZW.

(84) Designated States (unless otherwise indicated, for every
kind of regional protection available): ARIPO (BW, GH,
GM, KE, LR, LS, MW, MZ, NA, RW, SD, SL, ST, SZ,
TZ, UG, ZM, ZW), Eurasian (AM, AZ, BY, KG, KZ, RU,
TJ, TM), European (AL, AT, BE, BG, CH, CY, CZ, DE,
DK, EE, ES, FI, FR, GB, GR, HR, HU, IE, IS, IT, LT, LU,
LV, MC, MK, MT, NL, NO, PL, PT, RO, RS, SE, SI, SK,
SM, TR), OAPI (BF, BJ, CF, CG, CI, CM, GA, GN, GQ,
GW, KM, ML, MR, NE, SN, TD, TG).

Published:

- with international search report (Art. 21(3))
- before the expiration of the time limit for amending the
claims and to be republished in the event of receipt of
amendments (Rule 48.2(h))

(54) Title: METHOD AND SPHERICAL SEATING SYSTEM THAT PROTECTS VEHICLE OCCUPANTS FROM EFFECTS OF EXCESSIVE LOADS

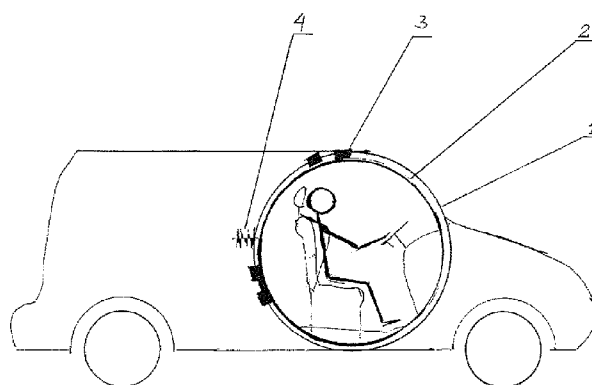

Fig. 9

(57) Abstract: The present invention includes method and seating system protecting passengers in particular from effects of excessive load force in objects impacted by rapid acceleration, which result in inertia influencing the aforementioned objects. The method protecting crew/passengers from effects of excessive loads is characterized by passenger compartment of the object influenced by the force is divided into firm sphere or cylinder shaped capsules. The seating system protecting passengers from effects of excessive load, where the passenger capsule under the torque caused by the acceleration of the vehicle or aircraft change of velocity, which induces excessive load forces. The device to protect passengers against the effects of excessive loads in vehicles and aircrafts characterized by the fact that it consists of two elements, fixed cabin shell (1) and rotating unit (2), where the fixed cabin element (1) is sphere or cylinder shaped and provides a bearing for rotating unit (2), which is a hollow sphere or cylinder shaped encompassed by the fixed part (1) and forms a capsule with passenger seats with safety belts to fasten passengers inside.



**Method and spherical seating system that protects vehicle occupants
from effects of excessive loads**

The present invention relates to method and spherical seating system protecting passengers in particular from effects of excessive loads in objects impacted by rapid acceleration, thus having high inertia force which negatively impacts these objects.

Method and spherical seating system protects passengers in particular from effects of excessive loading caused by rapid acceleration, deceleration, change of velocity or other actions of an object under linear movement and enables safe evacuation of passengers of an aircraft in an event of probable catastrophe. Once a predetermined load value is exceeded, the system converts inertia of passengers in linear movement into pressure on seats and heat resulting from friction of the spherical seating system. The system can be combined with similar safety devices such as: parachutes, safety belts or airbags for increased safety. Vehicle subjected to impact or any sudden velocity change causes excessive loads generation which negatively effects people and can lead to severe disability and even death.

However, the load factor can be significantly reduced by proposed method which is converting impact energy into extended deceleration distance and air resistance.

Polish patent application No. PL39776520120109 outlines a method of safely dissipating kinetic energy of moving objects exposed to a sudden impact. The above mentioned method utilises a device which converts kinetic energy into a mechanical rotor spin (the so called Łągiewka bumper) and thus decreasing the inertia force acting on vehicle occupants.

There are other known options such as use of strengthened construction of car body work and chassis to protect vehicle occupants during impact, especially from back or front impact. The energy of an impact is absorbed and load factor decreased by deformable bumper fixing, which is deforming accordingly to the level of resultant impact force generated.

The devices protecting people from the effect of collision impact includes airbags made from elastomer materials attached to front and/or back bumpers, designed to suit car shape and weight. The impact energy is converted into rebound energy which reduces load factor.

There are also existing systems of passive and active safety measures implemented by car manufacturers. The solutions relating to car passenger safety as in case of hitting a barrier are targeted at strengthening car construction and protecting passengers by safety belts and air bags. The kinetic energy of a car hitting a barrier deforms the car body, which combined with the safety belts reduces the loading which is impacting vehicle occupants.

However, none of these solutions decreases the force by extending the deceleration distance and time of rotating passengers after the vehicle has stopped moving. None of these methods sufficiently protects vehicle occupants spine and head by pressing them against profiled seatback and headrest. None of these solutions is suitable for passengers and crew to leave safely an airplane or helicopter in an event of a crash by catapulting cabin unit in which they are seated.

By including an additional system of active safety which can be combined with other devices of similar purpose, thus increasing responsiveness of the system during an impact for vehicles travelling at high speed.

This invention aims to implement a new method of protective seating system for vehicle and aircraft passengers impacted by excessive loads in events of collisions.

The essence of the method is based on the division of vehicle occupants compartment into smaller spherical or cylinder-shaped cabins, each accommodating a few crew/passengers. The cabins are composed of an inner rotating capsule unit 2, Figure 1, which is encompassed by an external fixed cabin shell 1, Figure 1 mounted in the base 3, Figure 1 of a vehicle 4, Figure 1 or a ship. The inertia of passengers that subjects them into linear motion due to acting forces, e.g. in car crashes is converted into F_b propulsive force in rotational motion and pressure on seats. In accordance with the principle of mechanics, the torque resulting from the inertia force F_b which acts on arm of X length between the S_o rotation center and S_c gravity center, Fig. 1 results in centrifugal force F_o . This results in T friction force, being a product of pressure (in this case the sum of the F_o centrifugal force and Q weight) and (μ) friction coefficient, and P air resistance, counteracting the movement. The energy of the rotating part of the inner cabin unit is converted into heat through friction and air resistance, which effectively eliminates harmful load.

The load factor can be reduced thus protecting crew/passengers in emergency situations in aircrafts and spacecrafts by ejecting the inner cabin they sit in in case of emergency. The cabin equipped with parachute attached on top and airbags on bottom becomes jolly (boats) as soon as it lands on ground or water Figure 2, Figure 3, Figure 4, Figure 5. The capsule, which is mounted to the immovable cabin shell with a catch or a bolt can be catapulted using a bullet hit similar to the ones used in airbags. The main principle of the system reduces

the effects of harmful loading on crew/passengers by rotation of spherical or cylinder-shaped capsule 2 inside of matching fixed hollow shell 1, around their rotation center.

The capsule made of resistant and light materials accommodates seats with safety belts to fasten passengers inside. The center of gravity of the rotating capsule 2 with its content is shifted from cabin shell rotation center by X distance perpendicularly to the direction of velocity.

When the load factor of linearly moving object, caused by abrupt acceleration or halt, exceeds a predetermined value, the torque force induces rotation of the cabin part 2, together with its passengers inside, towards the fixed part 1, which becomes a bearing for the first one. This allows for extending the deceleration distance only for the passengers inside the rotating unit (thus subjecting them to centrifugal force acting against their seats), even after the vehicle has come to a halt. The device is activated with a special safety lock, e.g. a bolt lock 4, which can be individually adjusted. In case of normal vehicle use, the device is inactive as the acting forces are smaller than designed and set threshold and thus does not affect regular operation.

Fig. 1 presents an exemplary illustration of the subject of the invention, Fig.2 presents construction scheme, Fig.3, Fig.4, Fig.5, Fig.6, Fig.7, Fig.8. presents scheme of installation in an object, Fig. 9 and Fig. 10 present device installed in a two-person vehicle with a trunk space, respectively, before and after collision, followed by 4 bolt lock release and rotating movement decreasing the load factor. Figure 11 shows 4-seat moving part of a cabin, Figure 12 presents plan view, wherein 5 back rest, 6 seat, 7 headrest, 8 seat belts to fasten passengers. Figure 13 shows fixed cabin shell consisting of two elements bolted together 9 with rotating unit inside the bearing 1 with an electromagnetic bolt lock controlled by logic ejection system. This system is designated for aircrafts.

The fixed cabin shell is mounted with screws to a vehicle, Fig.14 shows plan view. The 2 rotating unit is made of firm carbon or aramid fibers bonded with epoxy resin, which makes them light and durable. It can be accessed via two vertical oval-shaped openings. The driver faces also an additional horizontal opening. The fixed cabin shell has a matching openings. It consists of two halves bolted or welded together once the mobile part has been placed inside. The cabin is mounted with screws in the vehicle bearing. The vehicle is steered electronically. The 4 bolt is broken after exceeding 20G load factor.

The method and seating system protecting crew/passengers from effects of excessive loads allows to reduce its effects in horizontal, vertical and diagonal movement. It can be used in aviation and astronautics to reduce the impact of harmful loads on pilots, also in civil aviation, balloons, helicopters, parachutes, in all vehicle and water traffic, cable cars and amusement parks (rollercoasters, falling objects or carousels), elevators and cranes as well as in military vehicles to protect users from excessive loading in case of collisions, falls and explosions resulting from failure or other unfortunate random events.

Claims

1. The method protecting crew/passengers from the effects of excessive loads is characterized by crew/passenger compartment of vehicle subjected to excessive loading is divided into a number of spherical or cylinder-shaped capsule units, wherein the unit under, the torque caused by the acceleration of the vehicle or aircraft during sudden changes of its velocity, rotates, hence, reducing generation of excessive forces.
2. The object of claim 1, characterized by sphere or cylinder shaped cabin units mounted in a vehicle or an aircraft with bolts, enabling its release in an emergency situation.
3. The seating system to protect crew/passengers from effects of excessive forces loading in vehicles and aircrafts is characterized by the fact that it consists of two elements; fixed cabin shell (1) encompassing fully rotating capsule (2), wherein the fixed element (1) in the form of a hollow sphere or cylinder becomes a bearing for rotating unit (2), also a hollow sphere or cylinder, fitted into the fixed part (1) and forming a capsule with passenger seats and safety belts to fasten passengers inside.
4. The system characterised as per claim 3 can comprise of one or multiple cabins.
5. The system characterised as per claim 3 which is consisting of fixed cabin part (1) Figure 1 (mounted in the bearing of the hull) and rotating capsule (2) in Figure 1, which has its gravity center (S_c) Figure 1 shifted towards its rotation center (S_o) Figure 1 by X length.

6. The system characterised as per claim 3 which is consisting of fixed cabin part (1) Figure 1 (mounted in the bearing of the hull) and rotating capsule (2) in Figure 1, wherein line defined by the center of gravity (S_c) Figure 1 and the center of rotation (S_o) Figure 1 is not parallel to the direction of movement.
7. The system as per claim 3 is activated by frictional or magnetic bolt lock (4).
8. The system as per claim 3, wherein the rotating unit (2) of the cabin has vertical and/or horizontal oval openings at the level of the driver's face.
9. The system as per claim 3 characterized by fixed shell cabin (1) consists of two parts bonded together (9) with screws and/or rivet and/or welded together once it is assembled with the rotating unit (2).
10. The system as per claim 3 is built using strong fibers bonded together with resins for strength and lightness.

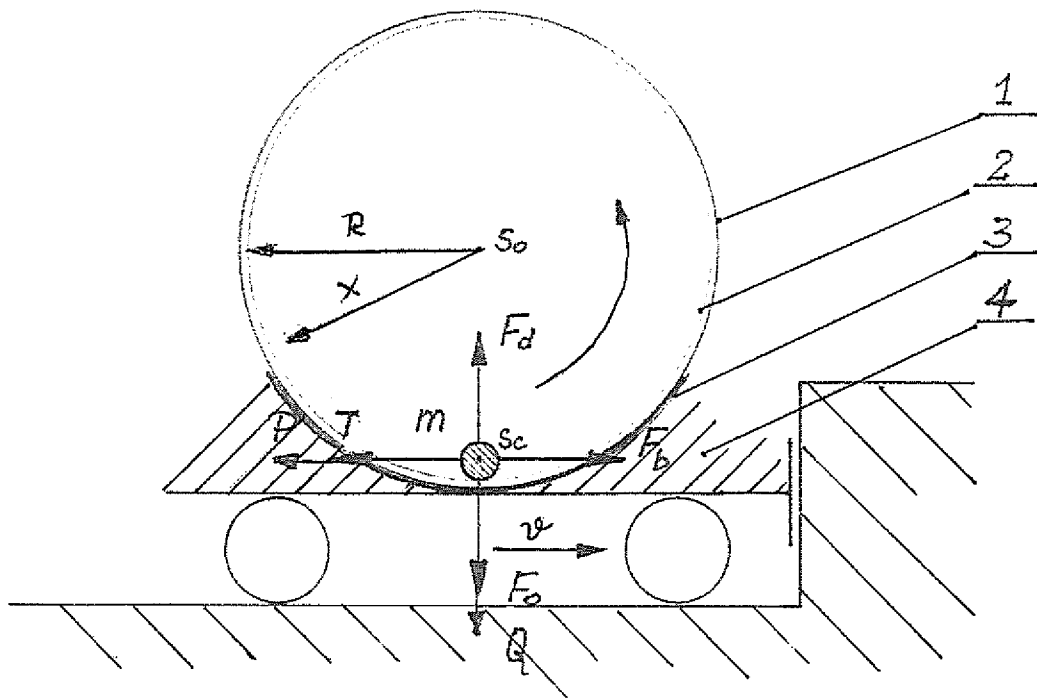

Fig. 1

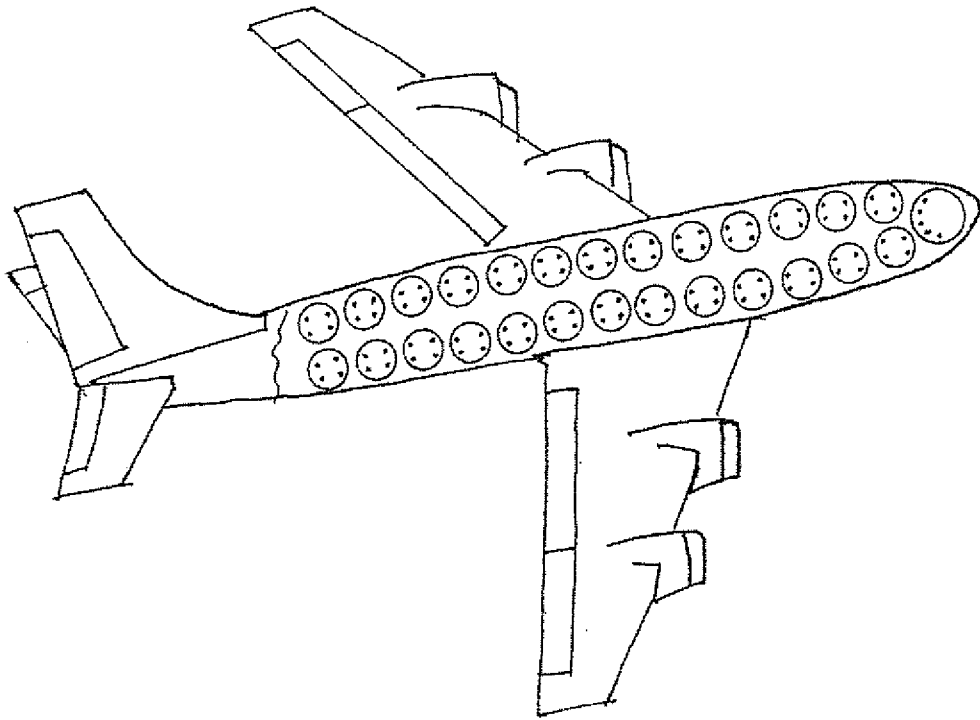

Fig. 2

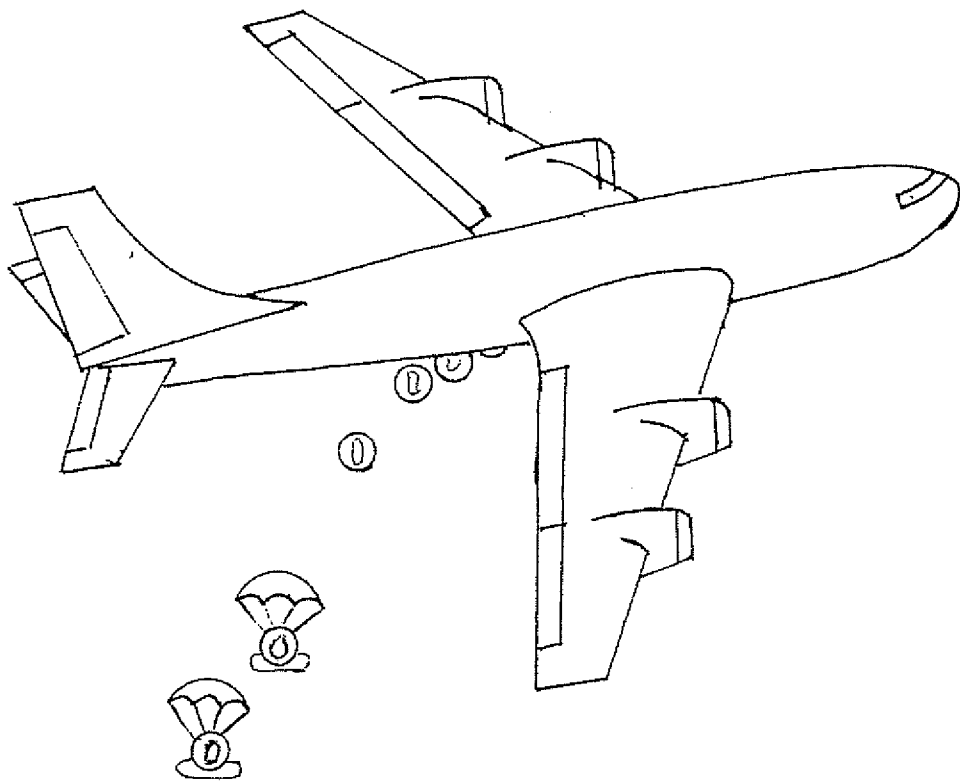

Fig. 3

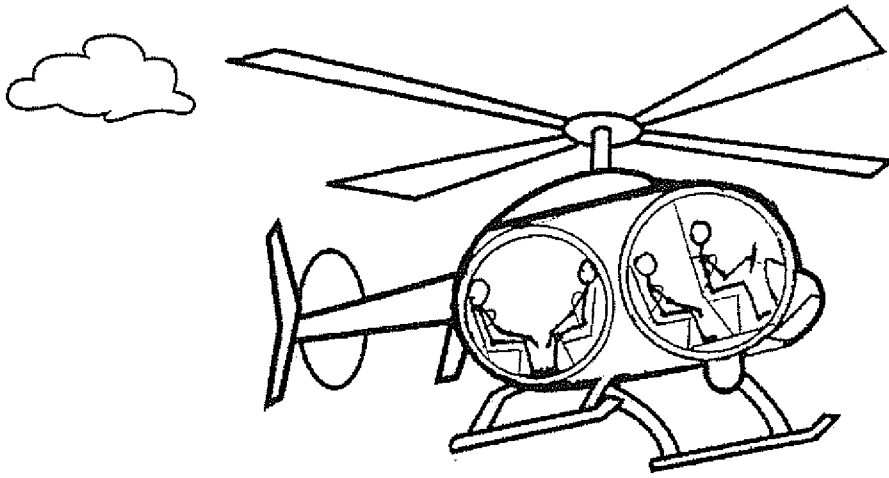

Fig. 4

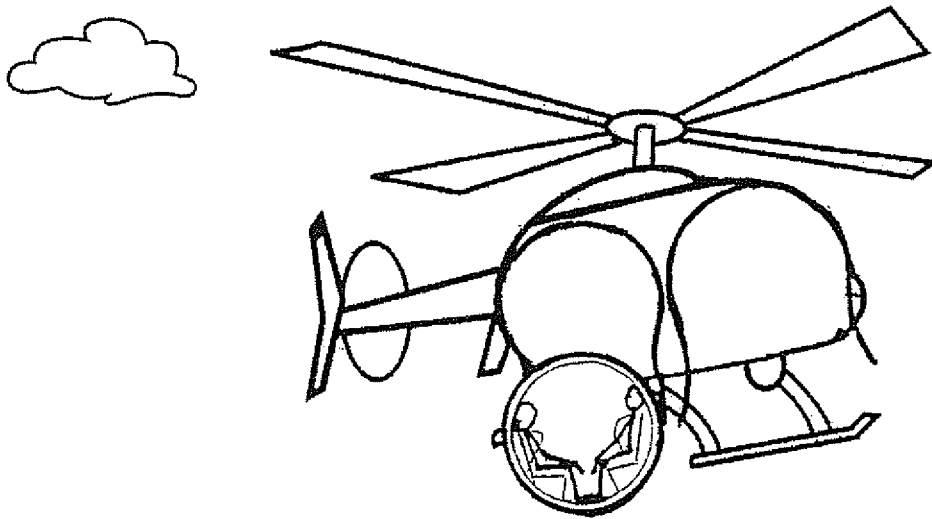

Fig. 5

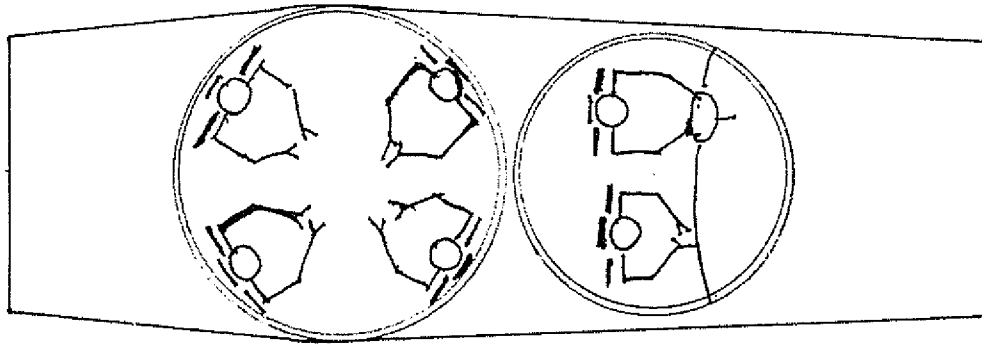

Fig. 6

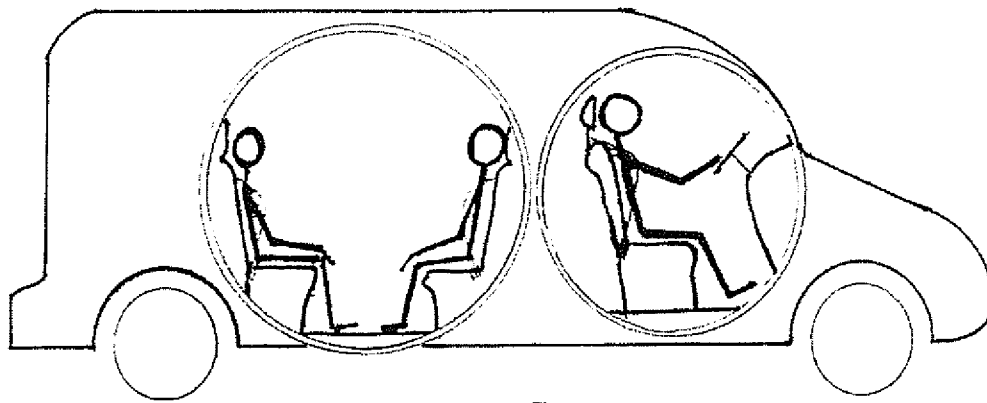

Fig. 7

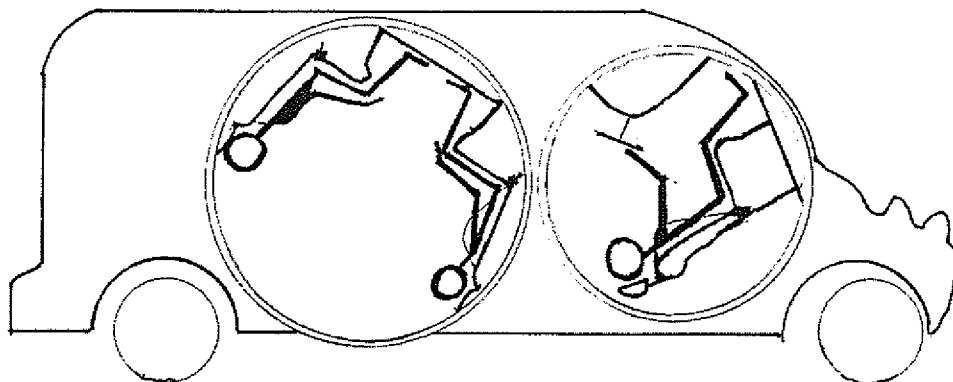

Fig. 8

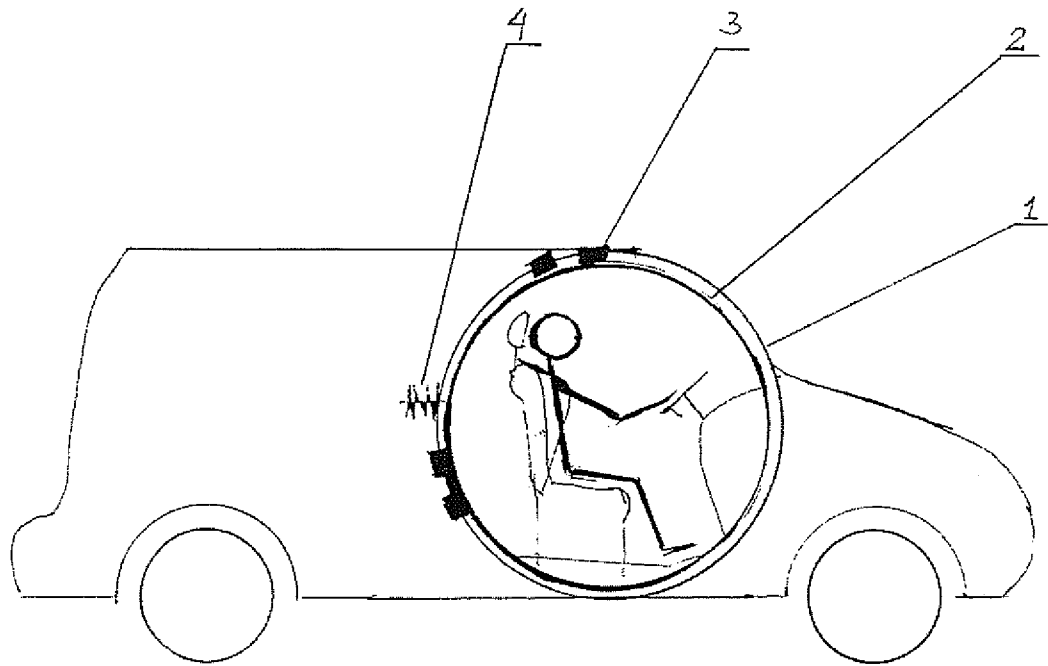

Fig. 9

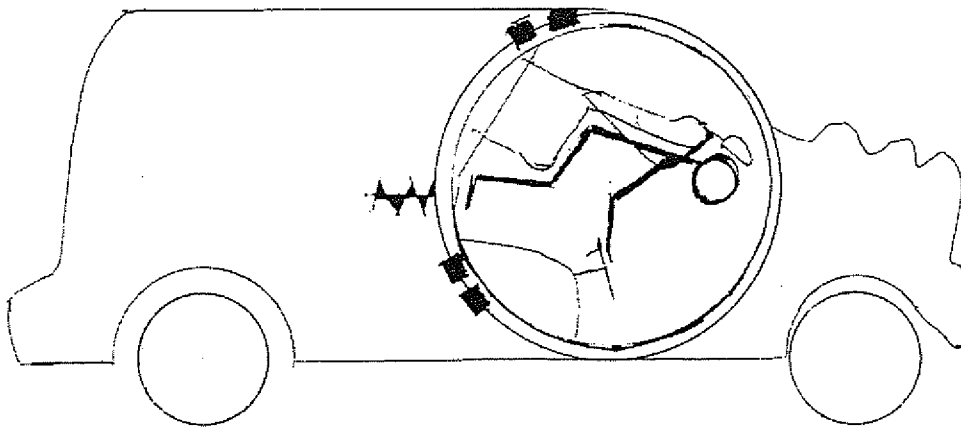

Fig. 10

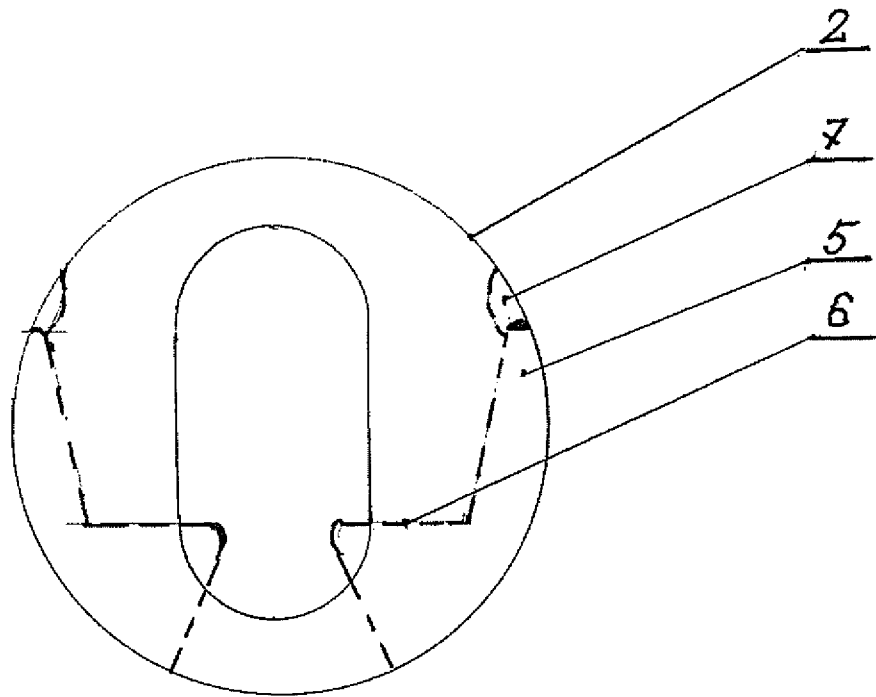

Fig. 11

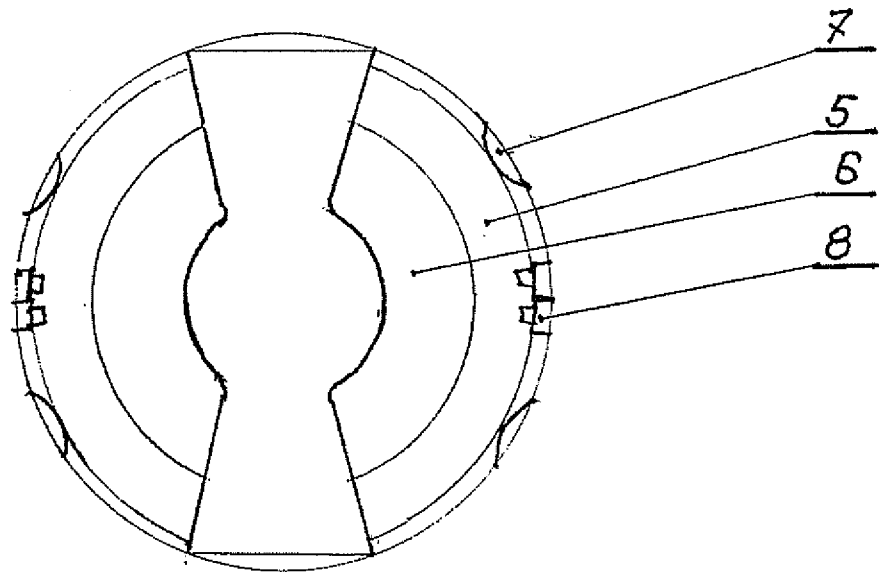

Fig. 12

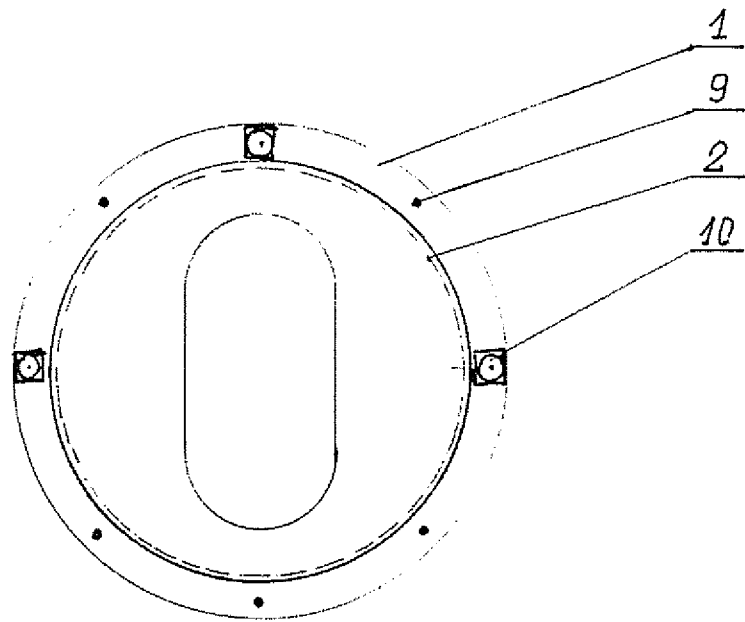

Fig. 13

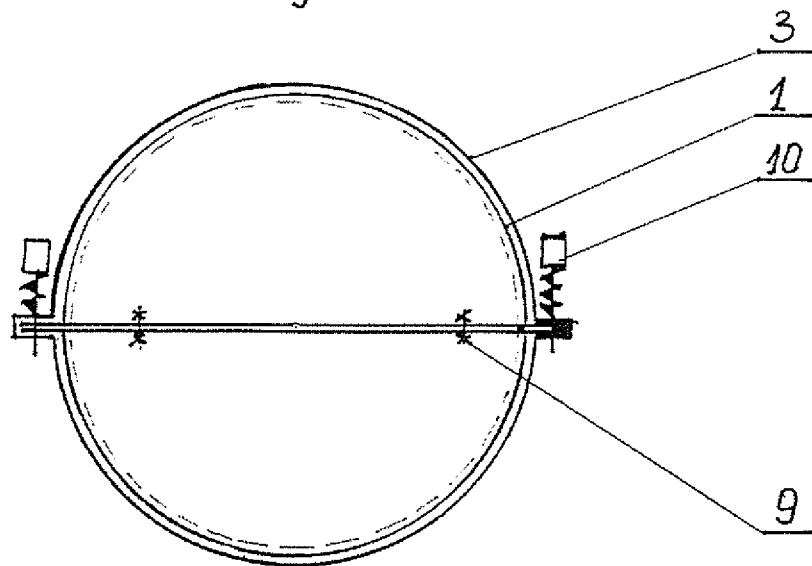

Fig. 14

INTERNATIONAL SEARCH REPORT

International application No.

PCT/PL2017/000001

| A. CLASSIFICATION OF SUBJECT MATTER B60N2/427 (2006.01); B60R21/00 (2006.01); B61F5/24 (2006.01); B61D17/00 (2006.01); B61D15/06 (2006.01); B62D39/00 (2006.01) According to International Patent Classification (IPC) or to both national classification and IPC | | |
|--|--|---|
| B. FIELDS SEARCHED Minimum documentation searched (classification system followed by classification symbols) B60N2, B60R21, B61F5, B61D17, B61D15, B62D39 Documentation searched other than minimum documentation to the extent that such documents are included in the fields searched Electronic data base consulted during the international search (name of data base and, where practicable, search terms used) EPO-Internal, Espacenet | | |
| C. DOCUMENTS CONSIDERED TO BE RELEVANT | | |
| Category* | Citation of document, with indication, where appropriate, of the relevant passages | Relevant to claim No. |
| Y | WO2004080779 A1 (Korea Railroad Res. Inst. et al., KR) 23.09.2004 the whole document | 1-10 |
| Y | EP1110861 A1 (Chiu Chui Wen, CA) 27.06.2001 paragraph [0004],[0055]-[0056], [0060], figures 2, 8, 14 | 1,3-4, 8,10 |
| Y | RU2181092 C1 (Khalidov G.J., Khalidov U.G., RU) 10.04.2002 figures, 2, 3, 4 | 1,3-4,8,10 |
| Y | KR101349656 B1 (Oh Han Jung, KR) 14.01.2014 abstract, paragraph [0017]-[0018], figures | 1,3-4,6,8,10 |
| Y | US3768417 A (Massachusetts Inst. Technol., US) 30.10.1973 abstract, column 6, line 38-line 41, figures 4, 5 | 1,3-4, 8,10 |
| <input type="checkbox"/> Further documents are listed in the continuation of Box C. <input checked="" type="checkbox"/> See patent family annex. | | |
| * Special categories of cited documents: "A" document defining the general state of the art which is not considered to be of particular relevance "E" earlier application or patent but published on or after the international filing date "L" document which may throw doubts on priority claim(s) or which is cited to establish the publication date of another citation or other special reason (as specified) "O" document referring to an oral disclosure, use, exhibition or other means "P" document published prior to the international filing date but later than the priority date claimed "T" later document published after the international filing date or priority date and not in conflict with the application but cited to understand the principle or theory underlying the invention "X" document of particular relevance; the claimed invention cannot be considered novel or cannot be considered to involve an inventive step when the document is taken alone "Y" document of particular relevance; the claimed invention cannot be considered to involve an inventive step when the document is combined with one or more other such documents, such combination being obvious to a person skilled in the art "&" document member of the same patent family | | |
| Date of the actual completion of the international search | | Date of mailing of the international search report |
| 16 May 2017 | | 17 May 2017 |
| Name and mailing address of the ISA/ Visegrad Patent Institute / Branch Office PL Al. Niepodległości 188, 00-950 Warsaw, Poland Facsimile No. +48 22 579 00 01 | | Authorized officer Dagmara Jarzyńska Telephone No. +48 22 579 06 97 |

INTERNATIONAL SEARCH REPORT
Information on patent family members

International application No.

PCT/PL2017/000001

| Patent document cited in search report | | Publication date | Patent family member(s) | | Publication date |
|--|-------|------------------|-------------------------|-------|------------------|
| WO 2004080779 | A1 | 23.09.2004 | AU 2003269541 | A1 | 30.09.2004 |
| | | | CN 1756684 | A | 05.04.2006 |
| ----- | ----- | ----- | ----- | ----- | ----- |
| EP 1110861 | A1 | 27.06.2001 | AU 1644801 | A | 24.07.2001 |
| | | | BR 0016914 | A | 29.10.2002 |
| ----- | ----- | ----- | ----- | ----- | ----- |
| RU 2181092 | C1 | 10.04.2002 | | | |
| ----- | ----- | ----- | ----- | ----- | ----- |
| KR 101349656 | B1 | 14.01.2014 | | | |
| ----- | ----- | ----- | ----- | ----- | ----- |
| US 3768417 | A | 30.10.1973 | DE 2235705 | A1 | 01.02.1973 |
| | | | US 3842751 | A | 22.10.1974 |