

E. THOMSON.
MEANS FOR EXTINGUISHING ELECTRIC ARCS.

APPLICATION FILED AUG. 1, 1902.

NO MODEL.

2 SHEETS—SHEET 1.

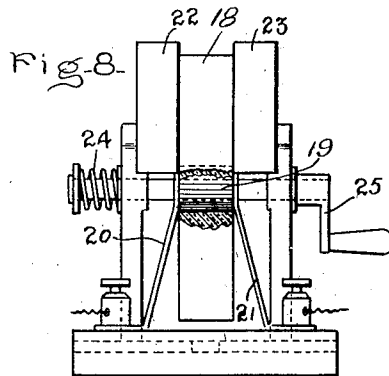
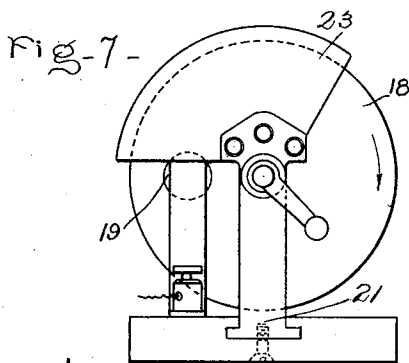
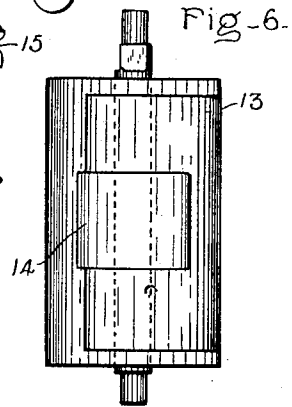
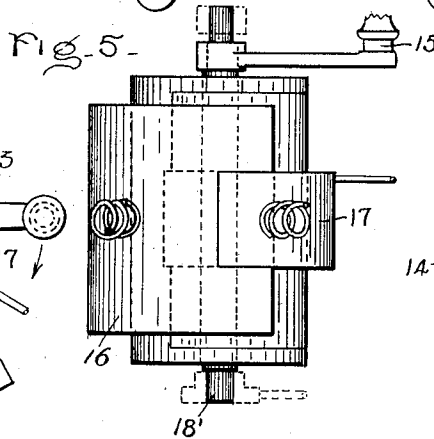
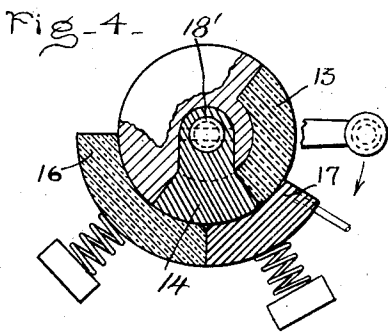
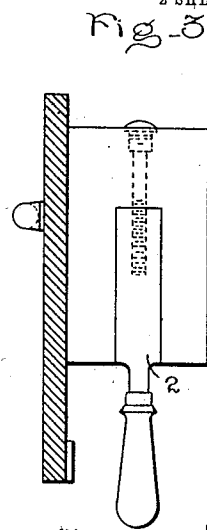
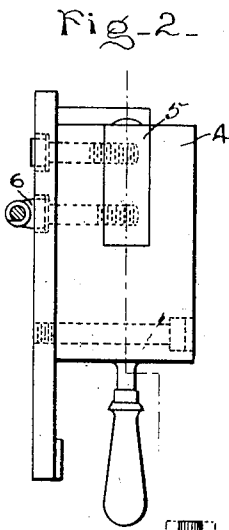
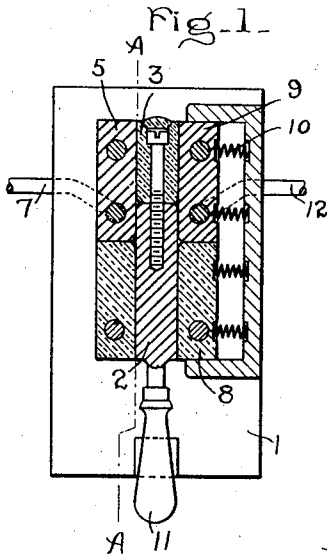

WITNESSES.

Robt L. Chapman
HeLEN Cofford

INVENTOR-

Elihu Thomson.

By, Albert S. Davis
Atty.

E. THOMSON.
MEANS FOR EXTINGUISHING ELECTRIC ARCS.

APPLICATION FILED AUG. 1, 1902.

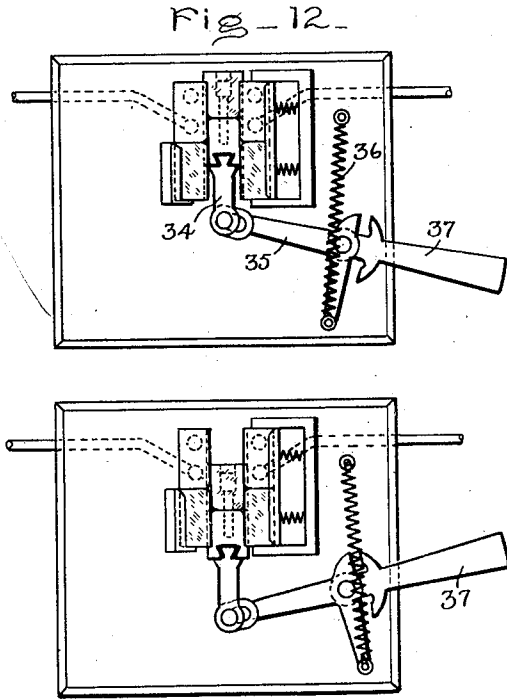
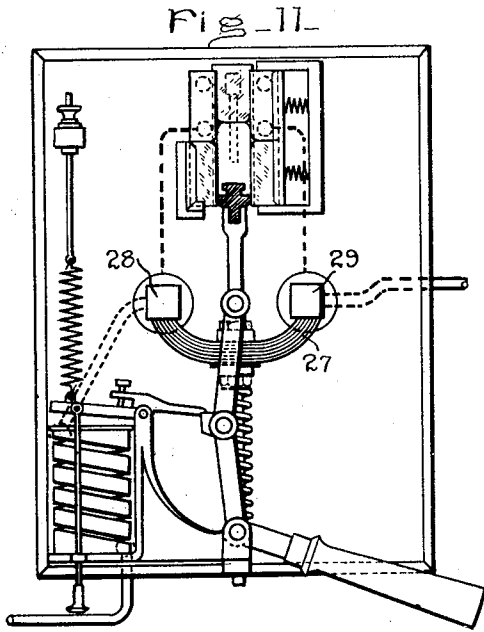
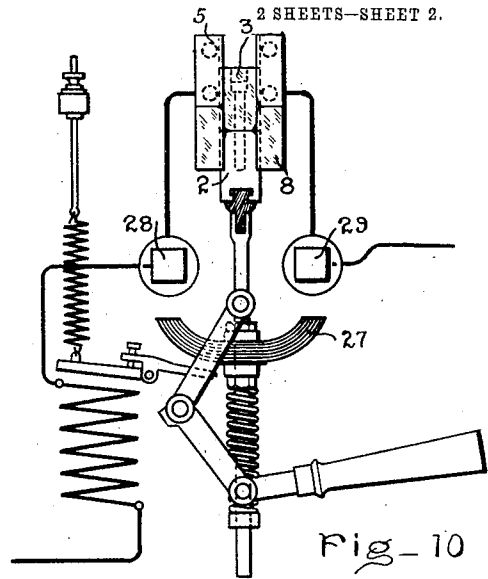
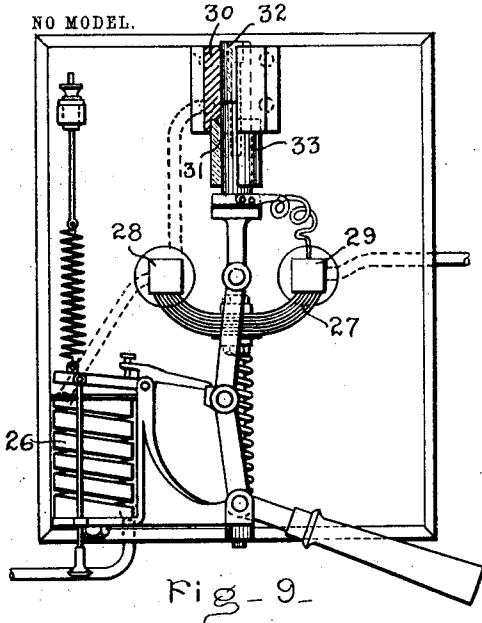

WITNESSES-

Robt. L. Chapman
Helen Corford

INVENTOR-
Elihu Thomson
By *Albert G. Davis*
Atty.

UNITED STATES PATENT OFFICE.

ELIHU THOMSON, OF SWAMPSCOTT, MASSACHUSETTS, ASSIGNOR TO
GENERAL ELECTRIC COMPANY, A CORPORATION OF NEW YORK.

MEANS FOR EXTINGUISHING ELECTRIC ARCS.

SPECIFICATION forming part of Letters Patent No. 751,028, dated February 2, 1904.

Application filed August 1, 1902. Serial No. 117,952. (No model.)

To all whom it may concern:

Be it known that I, ELIHU THOMSON, a citizen of the United States, residing at Swampscott, in the county of Essex, State of Massachusetts, have invented certain new and useful Improvements in Means for Extinguishing Electric Arcs, of which the following is a specification.

The present invention relates to an arc-extinguishing means, particularly useful in connection with circuit-breakers for electric circuits, in which when interrupted sufficient difference of potential exists to maintain a considerable length of arc. While particularly useful in this connection, the invention is of course of value in many other relations.

Briefly characterized, the invention consists in shearing or choking off the arc between walls of a substance highly refractory in nature and not subject to cracking or splintering under the influence of the intense heat of the arc. Hitherto attempts have been made to shear or cut off an arc, but without success, due to the lack of a material capable of standing the sudden and intense heat of the arc without damage or rupture. I have found that fused quartz possesses characteristics suitable for the purposes mentioned. This material may be secured in the desired shapes by fusing quartz, sand, or silica by the electric-arc or oxyhydrogen flame and then forming into shape.

The features of novelty which characterize my invention I have pointed out with particularity in the appended claims, while in the accompanying drawings, which are to be taken in connection with the following specification, I have illustrated a few of the various forms in which my invention may be embodied.

Figures 1, 2, and 3 illustrate one embodiment of my invention; Figs. 4, 5, and 6, another embodiment; Figs. 7 and 8, another modified form; Figs. 9, 10, and 11, the application of the invention to an automatic circuit-breaker, and Figs. 12 and 13 the application of the invention to a hand-operated snap-switch.

The switch shown in Fig. 1 includes a base

1, upon which are mounted the working parts 50 of the switch. The movable member of the switch consists of a rectangular block 2 of metal or other conducting material, having secured to its upper end a U-shaped block of fused quartz, the arms of the U extending 55 around so as to embrace the block 2, as will be more readily seen by reference to Fig. 3, in which the construction of the movable member is indicated in side elevation. The view shown in Fig. 3 is a section taken along 60 the line A A in Fig. 1. The movable member of the switch is confined between two walls, one of which is fixed to the base 1 and the other spring-pressed, so that the movable member is held in frictional engagement be- 65 tween the walls. The fixed wall, which is represented in section at the left of Fig. 1 and in side elevation in Fig. 2, consists of a U-shaped block or mass of fused quartz 4, between the arms of which is mounted a block of 70 copper or other conducting material 5. Bolts extend through the base 1 into the block 5 and also through the lower end of the block 4 and serve to hold the parts in rigid engagement with the base 1. One of the bolts, as 6, 75 serves to make electrical connection between the terminal 7 of the switch and the block 5. The movable wall of the switch is of construction similar to the fixed wall and consists of a 80 U-shaped block 8 of fused quartz, having a conducting-block 9 confined between its arms. This movable member is pressed by means of springs, such as 10, against the manually-actuated member 2 of the switch, to which the handle 11 is attached for the pur- 85 pose of manipulation. The other terminal or lead 12 of the switch is electrically connected to the conducting-block 9 by a bolt or otherwise, and has a limited amount of flexibility, so as to allow the very slight play necessary 90 to insure frictional engagement between the block 9 and the manually-actuated member of the switch. In the position of the parts, as indicated in the drawings, it will be noted that the conducting-block 2 is located between and 95 makes electrical contact with the conducting-blocks to which the terminals 7 and 12 of the switch are connected. To interrupt the cir-

cuit thus formed, the handle 11 is pulled down until the conducting-body 2 is removed from engagement with the fixed conducting-blocks 5 9. The arc which would be formed as the circuit is broken between these parts is instantly extinguished or sheared off by the quartz-block 3, which acts as a follower for block 2. The arc which forms as the circuit is interrupted is choked off or chilled out of existence, and the heat which accompanies the formation of the arc exerts no destructive action upon the operating parts of the switch, since the fused quartz of which the arc-extinguishing parts are formed is of such a refractory nature and possesses such an extremely low coefficient of expansion that it is not subject to damage by cracking, splintering, or fusing.

In Figs. 4, 5, and 6 the switch therein shown has a circular or rotary motion instead of the rectilinear motion of the switch, already described. In Figs. 4, 5, and 6 the rotary member of the switch consists of a cylinder, having suitably secured to the surface thereof and flush therewith a somewhat U-shaped body 13 of fused quartz, between the arms of which and likewise flush with the surface of the cylinder is a block 14 of metal or other conducting material. Motion may be communicated to the cylinder by means of the crank-arm 15 or any other suitable means. The cooperating member of the switch includes a U-shaped body 16 of quartz, (shown in section in Fig. 4 and in side elevation in Fig. 5,) which body is spring-pressed against the surface of the cylinder referred to. Between the arms of this U-shaped quartz body is mounted a spring-pressed block 17 of conducting material. One terminal of the switch is connected to this block 17 and the other terminal to the conducting-block 14 on the cylinder through the shaft 18' of the cylinder or by any other suitable means. When the switch is in closed position, so as to allow passage of current, the spring-pressed block 17 is in engagement with the conducting-block 14, as indicated, perhaps, best in Fig. 4. In order to break the circuit, the cylinder is rotated, so that the block 14 moves away from the spring-pressed block 17 and is followed up in its motion by the U-shaped block 13 of quartz, which, as the conducting-block 14 breaks engagement with the spring-pressed block 17, serves to shear off or destroy the incipient arc then formed.

A somewhat different form of rotary switch is shown in Figs. 7 and 8, in which the rotary member consists of a disk 18 of fused quartz, having extended through from side to side a plug 19 of conducting material. Contact-springs 20 and 21 are adapted to make engagement with the respective exposed surfaces of the plug, which when contact is made corresponds to the closed position of the switch. In order to suppress the arcs which tend to form as the plug is revolved out of

engagement with the contact-springs, I make use of two sector-shaped pieces 22 and 23 of fused quartz, between which the rotating disk 18 is yieldingly held by spring-pressure 24. As the crank 25 is turned the disk 18 is rotated, so as to carry the plug 19 out of engagement with the contact-springs 20 and 21 up into engagement with the walls of the sectors 22 23, bearing against the disk 8. As the portions of the conducting-plug, which are the last to make contact with the contact-springs, finally break contact incipient arcs are produced, which are immediately sheared off or smothered as the contact-piece slides into close engagement with the sectors 22 23, bearing upon the disk 8.

In Fig. 9 the invention is shown as applied to an automatic circuit-breaker of a well-known type. In this circuit-breaker excessive current in the tripping-coil 26 trips the circuit-breaker, which operation involves first withdrawing a bridging contact 27, which forms a short-circuit between two fixed contacts 28 and 29, connected, respectively, to an arc-extinguishing switch, which in this instance resembles that shown in Fig. 1 of the drawings. This arc-extinguishing switch consists of a hollow cylinder 30, carried by the base of the circuit-breaker, within which moves a cylinder formed of two connecting portions, the lower, 31, of copper or other conducting material and the upper, 32, of fused quartz. The fixed hollow cylinder is provided with a tubular extension 33, partially enveloping the conducting portion 31 of the movable cylinder. This movable cylinder is actuated simultaneously with the bridging contact 27, but is so arranged that its conducting portion 31 does not move out of electrical contact with the fixed conducting cylinder or tube 30 until after bridging contact 27 has broken engagement with the fixed contacts 28 and 29. The first action of the circuit-breaker is to throw all of the current through the arc-extinguishing switch at the top of the circuit-breaker, this action taking place as soon as the movable contact 27 has left its cooperating fixed contacts. The final operation in the action of the circuit-breaker takes place when the conducting-cylinder 31 moves out of electrical engagement with the conducting member 30. The breaking of the circuit thus occasioned is readily accomplished, since the arcs which tend to form are choked off in their incipient state by the follower 33, which interposes itself in the path of the current, thereby effectually interrupting the same, as already described.

Fig. 10 differs from Fig. 9 as to its essential features only as to the character of the arc-interrupting switch, which instead of being of the form shown in Fig. 9 is substantially the same as that illustrated in Figs. 1, 2, and 3, and therefore requiring no special description.

Fig. 11 is another view of the switch shown in Fig. 10; but with the parts illustrated in the closed position instead of open, as in Fig. 10.

Figs. 12 and 13 show a hand-operated snap switch, the arc-extinguishing members of which are the same as already described in connection with Figs. 1, 2, and 3. The movable member 34 of the switch is actuated by a pivoted arm or lever 35, adapted to be held by a spring 36 in either one of its extreme positions, the spring being so connected that its line of action passes from one side to the other of the pivotal point of the lever as the lever moves from one extreme position to the other. To actuate this lever, I make use of a handle 37, which by the lost-motion connection between it and the lever causes the lever to snap into either of its extreme positions when operated.

What I claim as new, and desire to secure by Letters Patent of the United States, is—

1. A means for making and breaking an electric circuit, consisting of two conducting members adapted to be brought into contact with each other, and a mass of fused quartz arranged to be inserted in the path of an arc or arcs which tend to form as the conducting members are separated.

2. An electric switch consisting of a fixed member having contiguous portions of conducting and non-conducting materials respectively, a relatively movable member having a conducting portion adapted to make contact with the conducting portion of the fixed member, and a mass of fused quartz carried by the movable member and arranged to interrupt the path of an arc or arcs which tend to form as the conducting portion of the fixed and movable members are moved out of engagement with each other.

3. In an electric contact making and breaking device, the combination of two relatively movable contact-pieces adapted to make contact with each other and arranged so that the area of contact progressively decreases until contact is broken, and masses of fused quartz arranged to closely surround the area of contact and entirely fill the space between the contact members when contact is broken.

In witness whereof I have hereunto set my hand this 30th day of July, 1902.

ELIHU THOMSON.

Witnesses:

DUGALD MCK. MCKILLOP,
HENRY O. WESTENDARP.