

Nov. 27, 1962

J. G. VERGOBBI
WEB FEEDING APPARATUS

3,065,675

Filed June 27, 1961

3 Sheets-Sheet 1

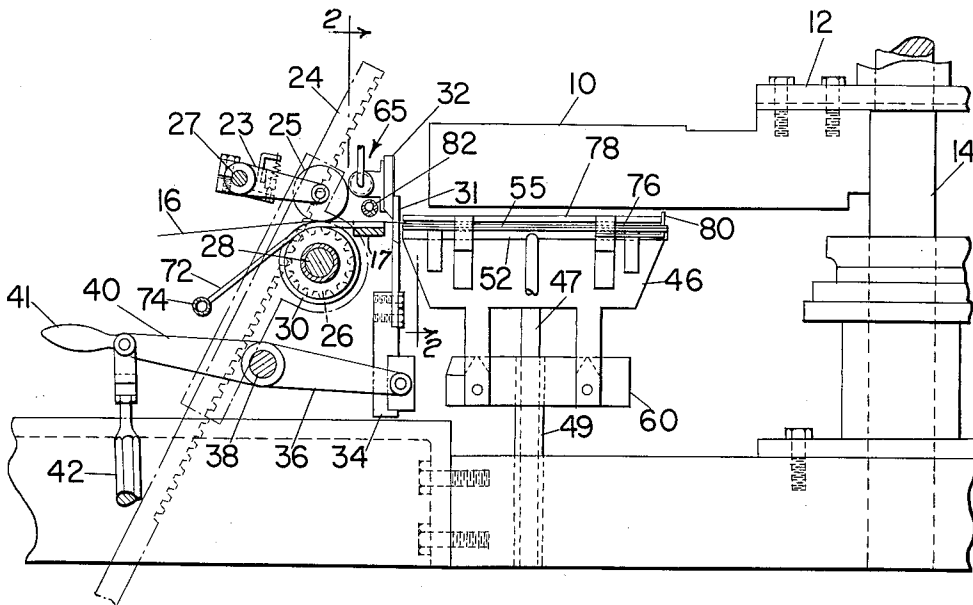

Fig. 1

INVENTOR.
John G. Vergobbi
BY *Robert C. Churchill*
ATTORNEY

Nov. 27, 1962

J. G. VERGOBBI
WEB FEEDING APPARATUS

3,065,675

Filed June 27, 1961

3 Sheets-Sheet 2

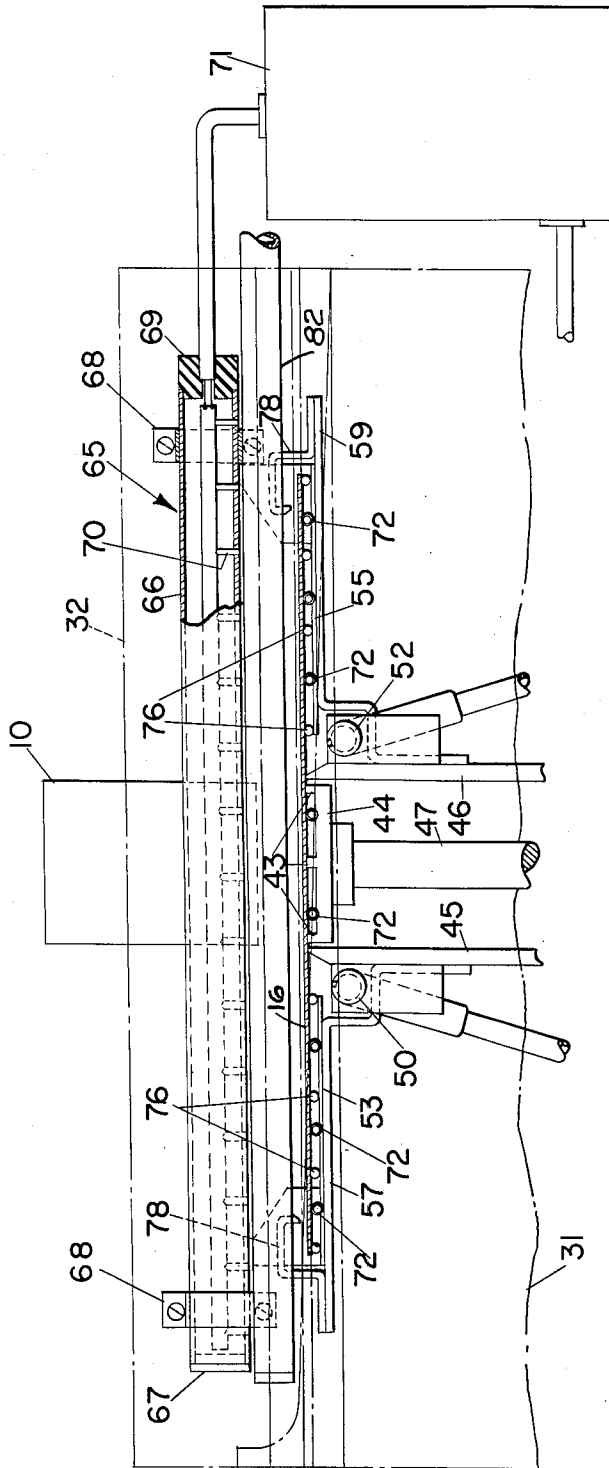

Fig. 2

INVENTOR.
John G. Vergobbi
BY *Robert A. Churchill*
ATTORNEY

Nov. 27, 1962

J. G. VERGOBBI
WEB FEEDING APPARATUS

3,065,675

Filed June 27, 1961

3 Sheets-Sheet 3

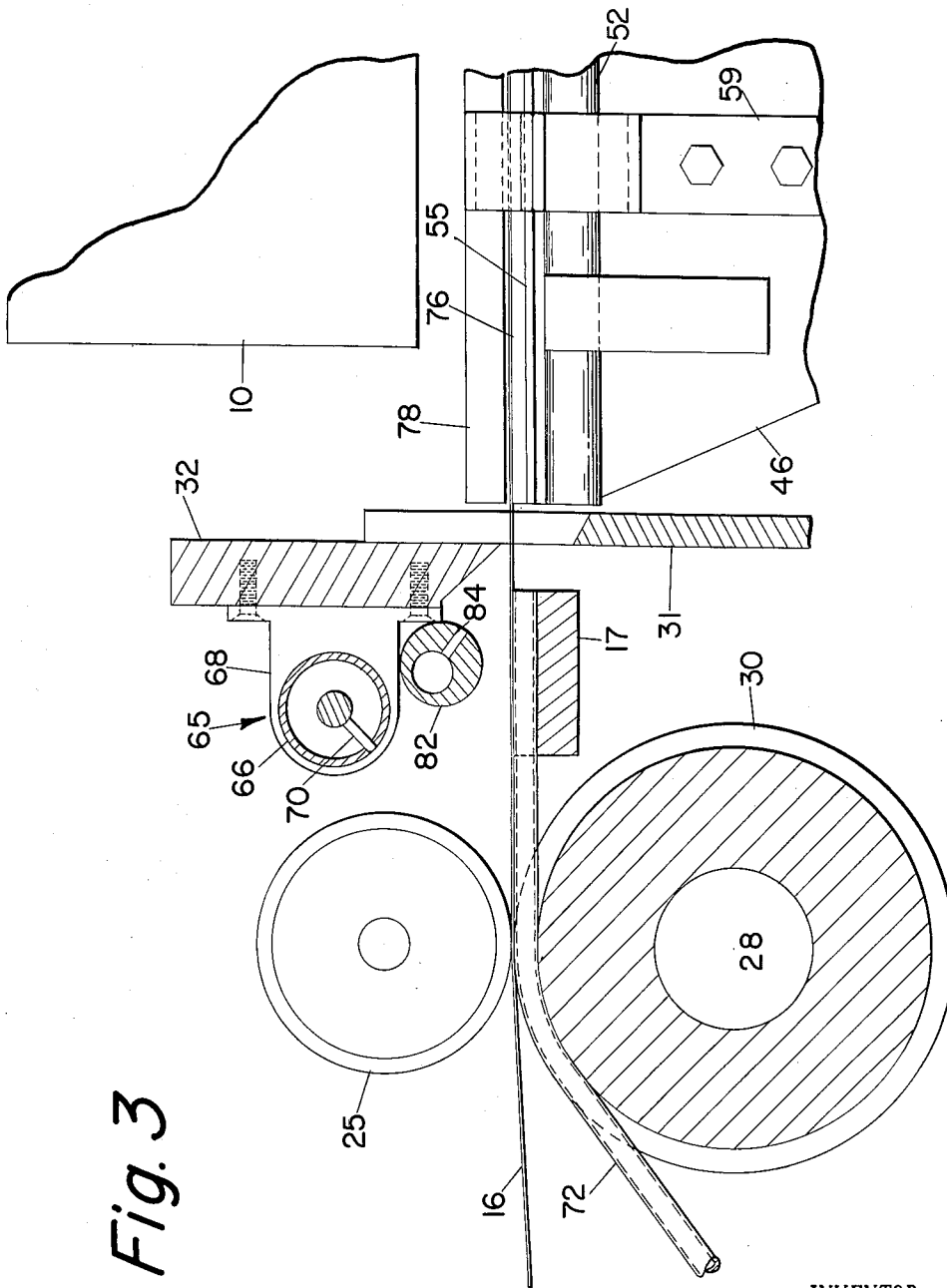

Fig. 3

INVENTOR.
John G. Vergobbi
BY
Robert A. Churchill
ATTORNEY

1

3,065,675

WEB FEEDING APPARATUS

John G. Vergobbi, Quincy, Mass., assignor to Pneumatic Scale Corporation, Limited, Quincy, Mass., a corporation of Massachusetts

Filed June 27, 1961, Ser. No. 120,003

1 Claim. (Cl. 93—36.01)

This invention relates to web feeding apparatus.

The invention has for an object to provide novel and improved web feeding apparatus wherein provision is made for controlling the leading portion or free end of a relatively thin, lightweight flexible web of sheet material which is also subject to the effects of static electricity during the feeding operation to the end that such web may be successfully advanced into a predetermined position in a simple and highly efficient manner.

With this general object in view and such others as may hereinafter appear, the invention consists in the web feeding apparatus and in the various structures, arrangements and combinations of parts hereinafter described and particularly defined in the claims at the end of this specification.

In the drawings illustrating the preferred embodiment of the invention:

FIG. 1 is a side elevation partly in cross section of a portion of a container forming machine embodying the present web feeding apparatus;

FIG. 2 is a front elevation of the same as viewed from the line 2—2 of FIG. 1, some of the parts being shown in cross section; and

FIG. 3 is a cross sectional detail view at an enlarged scale of a portion of the web feeding apparatus shown in FIG. 1.

In general the present invention contemplates novel web feeding mechanism particularly adapted for feeding a web of relatively thin, lightweight flexible sheet material, which is also subject to the effects of static electricity, into operative position to be severed to form an individual sheet or blank of container forming material. The invention is herein illustrated as embodied in a container forming machine of the type adapted to form a lined container wherein a severed blank of liner material is wrapped about a forming block to form a tube at one station of operation, and at succeeding stations of operation the extended end of the tube is folded to provide a bottom closure whereupon an outer sheet of container forming material is wrapped about the forming block and the liner and provided with a bottom closure to form a lined container which may then be removed from the forming block ready to be filled and provided with a top closure. Inasmuch as the details of such container forming machines are well known and of themselves constitute no part of the present invention, only sufficient portions of such machines are herein illustrated and described to enable the present invention to be understood.

Prior to the present invention provision was made for controlling the movement of the leading portion of a web of thin, flexible sheet material as it was advanced onto a support by causing a stream of air to flow along the underside of the leading portion of the sheet in the direction of movement of the paper. Such web controlling apparatus is illustrated and described in my United States Patent No. 2,596,625, issued May 13, 1952.

However, when it was attempted to feed relatively thin thermoplastic sheet material, such as a "Pliofilm," in this manner, it was found that the static electricity generated by the passage of the material between the feed rolls caused the material to be attracted to and adhere to the supporting elements, thus rendering it practically impossible to successfully advance such material.

2

In accordance with the present invention provision is made for neutralizing and balancing such electrostatic charges as the material emerges from between the feed rolls so that the relatively thin, lightweight material may be successfully advanced onto the supporting elements with the assistance of the flow of air along the underside of the web in the direction of movement of the web. In addition, the surfaces of the supporting elements over which the thermoplastic sheet material is fed are preferably coated with an antistick material, such as "Teflon," to reduce friction to a minimum between the material and the supporting elements.

Referring now to the drawings, 10 represents a forming block secured to a disk 12 mounted upon a central shaft 14. In practice a plurality of horizontally extended forming blocks 10, only one of which is shown, are intermittently moved to present the forming blocks to the various container forming stations of the machine to produce a lined container. In the illustrated embodiment of the invention a web of sheet material 16, which may comprise an elongated strip of thermoplastic material, such as "Pliofilm," may be unwound from a roll thereof, not shown, and advanced by intermittently operated feeding mechanism across a bridge plate 17 and onto supporting and folding elements to present the leading end of the strip in operative position beneath the forming block 10. The intermittently operated feeding mechanism may be of a known type wherein a reciprocable rack 24 in mesh with a gear 26 is operated to rotate a shaft 28 upon which the feed roll 30 is mounted to advance a predetermined length of the web each cycle of operation during the upstroke of the rack 24. A plurality of cooperating pressure rollers 25 carried by arms 23 mounted on a rocker shaft 27 may be resiliently urged toward the feed roller 30 to effect advancement of the web. The gear 26 may form part of a known clutch mechanism which is arranged to release the shaft 28 during the downstroke of the rack.

After the leading portion of the strip is positioned, as described, the strip may be severed by a vertically reciprocable knife blade 31 which cooperates with a stationary blade 32 secured to the machine frame. The blade 31 is attached to spaced connecting blocks 34 carried by spaced arms 36 mounted on a shaft 38. One of the arms 36 is provided with a second arm 40 which is connected by a link 42 to operating mechanism forming a part of the container forming machine and which is arranged to operate the blade 31 to sever the strip in timed relation to the operation of the feeding mechanism. The arm 40 may be provided with a handle 41 to permit manual operation.

The rectangular blank thus severed from the strip is supported beneath the forming block 10 on top of the folding elements which may comprise vertically reciprocable members, including a horizontal bottom plate 44 and vertical side plates 45, 46, each side plate being provided with laterally extended blank supporting plates 53, 55 carried thereby. The side plates 45, 46 and the bottom plate 44 are arranged to be elevated to wrap the blank about the bottom and two sides of the block 10. The bottom plate 44 may be secured to the upper end of a shaft 47 arranged to be reciprocated through cam operated mechanism, not shown, forming a part of the container forming machine. The laterally extended supporting plates 53, 55 are secured to brackets 57, 59 attached to and movable with the vertical side plates 45, 46. The vertical side plates 45, 46 are secured to a bracket 60 attached to the upper end of a sleeve shaft 49 surrounding the shaft 47 and supported for reciprocation in the machine frame in a known manner. In operation the bottom plate 44 is elevated to present and retain the blank in firm engagement with the underside of the block while the side plates 45, 46 continue upwardly to wrap the blank against the sides of the block,

leaving opposed marginal portions of the blank extended upwardly beyond the top surface of the horizontally extended block. Air jets 50, 52, carried by the side plates 45, 46, are arranged to direct streams of air against the extended portions to maintain the same in operative position to be engaged by folding and sealing mechanism, not shown, to provide a longitudinally extended side seam.

In accordance with the present invention when the material being handled comprises a relatively thin, light-weight flexible sheet material, such as "Pliofilm," and which is also subject to the effects of static electricity, difficulties are encountered in advancing the leading end of the web across the bridge plate 17 and onto the supporting and folding elements 44, 45, 46 and 53, 55 because of the lack of rigidity of the material, and also because of the adverse effects of static electricity. The electrostatic effect is particularly crucial at the point where the web emerges from between the intermittently operated feed roller 30 and the pressure rollers 25. This is because in practice the web is initially unwound continuously from a supply roll at a predetermined rate such as to permit cyclical advance of the leading end in an amount equal to the length to be severed, that is, during the rest period of the intermittently operated feed roll 30 a predetermined length is being continuously unwound from the supply roll, suitable take-up mechanism being provided to maintain the web taut between the supply roll and the feed roller 30. During the feeding operation, the feed roller 30 is operated with a short over-feeding action to pull the web up taut at the end of the feeding operation, and as a result the roller 30 slips on the web a short distance at the end of the feeding stroke, thus creating friction between the roller and the web and generating electrostatic charges at this point.

In order to neutralize the electrostatic charges thus generated, whether they be positive or negative, an elongated static eliminator rod indicated at 65 is provided. The rod 65 is enclosed in a tubular metal housing 66 provided with insulating caps 67, 69, respectively, at each end and is secured by clamps 68 to the rear face of the stationary cutter blade 32. The static eliminator rod is provided with a row of radially extended pins 70 and is in electrical connection with a source of high voltage indicated by the power unit 71. The rod creates an ionized field which supplies enough of the opposite polarity to restore electrical balance instantly. In operation the field is filled with positive and negative charges which are then unbalanced with a preponderance of positive charges. If the material is charged with one kind it first attracts enough of the opposite charges out of the ionized field until it is satisfied, and meanwhile it repels the charges in the ionized field of the same polarity as itself which are attracted to earth through the feed roller or the metal housing. Thereafter, with the charge in the material neutralized, both negative and positive charges in the ionized field are grounded.

In the illustrated embodiment of the invention the static eliminator rod 65 extends across the width of the web with the row of pins 70 arranged to direct their charges at a point in the web just as it emerges from the feed rollers 30 and 25 as shown. In practice the rod is placed as close as practical to the material to be neutralized, that is, between 1/2" to 1 1/2" away from the material.

The web of material thus neutralized is free to be advanced across the supporting elements into operative position to be severed. However, because of the lack of rigidity of the material it is also necessary to control the advance of the leading end of the material by the provision of a plurality of spaced air tubes or jets indicated at 72 arranged to direct streams of air along the underside of the web as it is being advanced. As herein illustrated, the tubes 72 are connected at one end to an air manifold 74 and extend upwardly therefrom around the feed roller 30 in spaced peripheral grooves provided in the roller and then extend horizontally to assume a posi-

tion parallel to and immediately beneath the web being advanced. The forward ends of the tubes 72 are supported in grooves provided in the bridge plate 17, and the open ends of the tubes terminate at a point immediately in front of the cutter blades as shown.

The web supporting elements comprising the bottom plate 44, side plates 45, 46 and the laterally extended plates 53, 55 carried thereby are designed to reduce friction between the material and the supporting elements to a minimum so as to assist free passage of the leading end of the material thereacross. Thus, as illustrated in FIG. 2, the bottom plate 44 is provided with a plurality of upstanding and relatively narrow lands or ribs 43 extending in the direction of travel of the web, and the vertical side plates 45, 46 are tapered at their upper ends so that the web bridges across the lands and the tapered ends of the side plates as it is advanced. Also, the laterally extended plates 53, 55 are provided with spaced, parallel ribs or rods 76 extending in the direction of web movement and secured to the plates by welding or brazing. Thus, in operation the web being advanced bridges over the plates 53, 55 and rides on the crests of the ribs 76 and the lands 43 with a minimum of friction. In operation the streams of air projected from the tubes 72 pass between the underside of the web and the supporting elements, the air streams being confined to move along channels between the ribs 76 and between the lands 43. The laterally extended supporting plates 53, 55 may also be provided with suitable side guides 78 and end stops 80 as shown.

By confining the streams in this manner their velocity is preserved and turbulence prevented. The velocity of the streams below the web produces a suction effect holding the free end of the web down on the crests of the ribs and preventing upward curl of the leading edge of the thin web. With this construction it will be seen that the effects of friction between the web and the supporting elements are reduced to a minimum, and in addition the substantially friction-free passage of the web over the supporting elements also precludes any subsequent electrostatic attraction between the web and the supporting elements which might otherwise occur after the web passes beyond the influence of the static eliminator rod 65. In order to further reduce the effects of friction and electrostatic attraction during the feeding operation the crests of the ribs 76 and the upper ends of the side plates 45, 46 and the upper surface of the lands 43 may and preferably will be coated with an antistick material, such as "Teflon."

It will be observed that at the start of the feeding operation the leading edge of the web 16 is aligned with the cutting edges of the blades 31, 32, and the streams of air from the tubes 72 are directed along the underside of the leading edge. In order to counteract any tendency of the leading edge to move upwardly at this time provision is made for also directing streams of air along the upper surface of the leading edge of the web. As herein shown, an elongated air tube 82, also attached to the rear face of the stationary blade 32, is provided with a plurality of openings 84 arranged to direct streams of air under the stationary blade 32 and along the upper surface of the web. The tube 82 may be provided with an eccentric bore, as shown, and the openings 84 are formed in the thicker wall portion thereof whereby to more efficiently control the direction of the streams of air. The air tubes may be connected to a suitable source of compressed air, and in operation the air from the tube 82 and the tubes 72 may be controlled to maintain the leading edge extended at the start of the feeding operation so as to pass smoothly onto the supporting and folding elements.

From the above description it will be seen that the present apparatus is capable of successfully feeding a relatively thin web in a manner such as to overcome the effects of friction and electrostatic attraction to effect a

5

smoothly operating and positive feeding movement such as to maintain the leading end of the web in its fully extended position during the feeding operation.

While the preferred embodiment of the invention has been herein illustrated and described, it will be understood that the invention may be embodied in other forms within the scope of the following claims.

Having thus described the invention, what is claimed is:

In apparatus of the character described, in combination, means for receiving and supporting the leading end of a web of container forming material, web feeding means including cooperating feed rolls for intermittently advancing a predetermined length of the web onto said supporting means, means for severing the advanced portion of the web to provide a container forming blank, said severing means including an upper stationary cutter blade and a lower movable cutter blade, a bridge plate extending between the feed rolls and the severing means and terminating a short distance in front of the severing means leaving the leading end of the web unsupported between the bridge plate and said supporting means after a severing operation, and means for controlling said leading end during subsequent intermittent advancement of the web onto said supporting means including an elongated static eliminator rod disposed intermediate the feed rolls and the cutter blades and supported by said station-

5

10

15

20

25

6

ary cutter blade whereby to neutralize and balance any electrostatic charges in the material prior to passing over said supporting means, means carried by said bridge plate for directing streams of air along the undersurface of the leading end of the web in the direction of movement of the web, and means supported by said stationary blade for directing streams of air under said blade and against the upper surface of the leading end of the web at the start of the feeding operation when the leading end is aligned with the cutting edges of the blade whereby to counteract any tendency of the free and unsupported leading end of the web to move upwardly at the start of the feeding operation and to pass smoothly onto said supporting means.

References Cited in the file of this patent

UNITED STATES PATENTS

940,431	Chapman	Nov. 16, 1909
1,782,712	Chapman	Nov. 25, 1930
2,087,915	Kimball	July 27, 1937
2,736,106	Offen	Feb. 28, 1956
2,828,123	Guillemette	Mar. 25, 1958
2,848,820	Wallin et al.	Aug. 26, 1958
2,966,832	Vergobbi	Jan. 3, 1961
2,990,990	Wilkins et al.	July 4, 1961