



US00D780659S

(12) **United States Design Patent**
Liffick

(10) **Patent No.:** **US D780,659 S**

(45) **Date of Patent:** **** Mar. 7, 2017**

(54) **VEHICLE WHEEL**

(71) Applicant: **Quarsa, LLC**, Chino, CA (US)

(72) Inventor: **Fenton Liffick**, Anaheim Hills, CA (US)

(73) Assignee: **QUARSA, LLC**, Chino, CA (US)

(**) Term: **15 Years**

(21) Appl. No.: **29/541,666**

(22) Filed: **Oct. 6, 2015**

(51) **LOC (10) Cl.** **12-16**

(52) **U.S. Cl.**
USPC **D12/211**

(58) **Field of Classification Search**

USPC D12/204–213
CPC B60B 7/00; B60B 7/01; B60B 7/02; B60B 7/04; B60B 7/06; B60B 3/02; B60B 3/04; B60B 3/06; B60B 3/10; B60B 1/00; B60B 1/08; B60B 1/10; B60B 1/12
See application file for complete search history.

(56) **References Cited**

U.S. PATENT DOCUMENTS

D350,932 S *	9/1994	Echazabel	D12/211
5,988,762 A *	11/1999	Asada	B60B 7/02 264/266
D430,526 S *	9/2000	Fitzgerald	D12/211
D527,335 S *	8/2006	Kim	D12/211

D549,150 S *	8/2007	Young	D12/211
D569,776 S *	5/2008	Hieke	D12/211
D622,196 S *	8/2010	Gallert	D12/209
D625,245 S *	10/2010	Hans	D12/211
D634,252 S *	3/2011	Johnson	D12/211
D659,071 S *	5/2012	Hale, Jr.	D12/211
D662,025 S *	6/2012	Ettensberger	D12/209
D709,019 S *	7/2014	Hale, Jr.	D12/211
D727,827 S *	4/2015	Chung	D12/211
D751,481 S *	3/2016	Chung	D12/209
D760,142 S *	6/2016	Chu	D12/211
2003/0020322 A1 *	1/2003	Zaniboni	B60B 7/0013 301/37.101

* cited by examiner

Primary Examiner — Holly Baynham

Assistant Examiner — Katherine Glennon

(74) *Attorney, Agent, or Firm* — Snell & Wilmer LLP

(57) **CLAIM**

I claim the ornamental design for a vehicle wheel, as shown and described.

DESCRIPTION

FIG. 1 is a perspective view of the vehicle wheel showing my new design; FIG. 2 is a front view of the vehicle wheel; and, FIG. 3 is a cross-sectional view taken along the line 3-3 of FIG. 2.

The broken lines showing the rear portion of the vehicle wheel are included for the purpose of illustrating environment and forms no part of the claimed design.

1 Claim, 3 Drawing Sheets

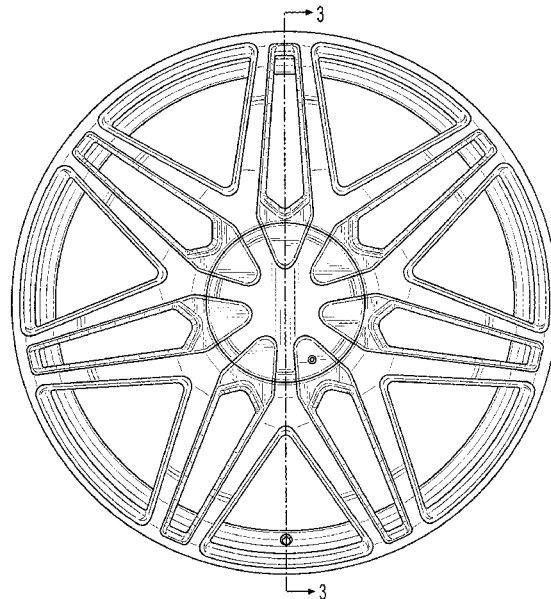
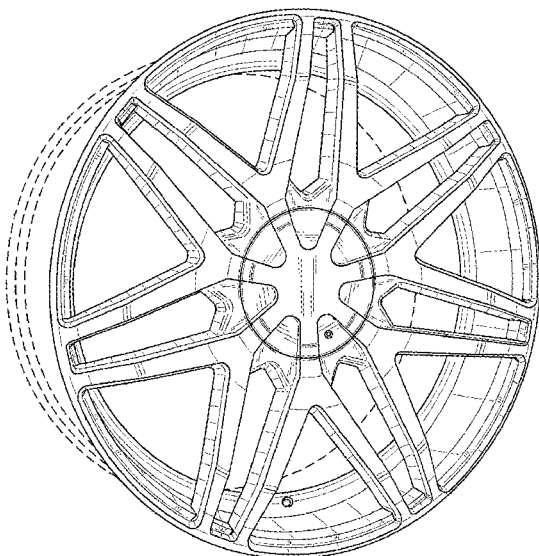

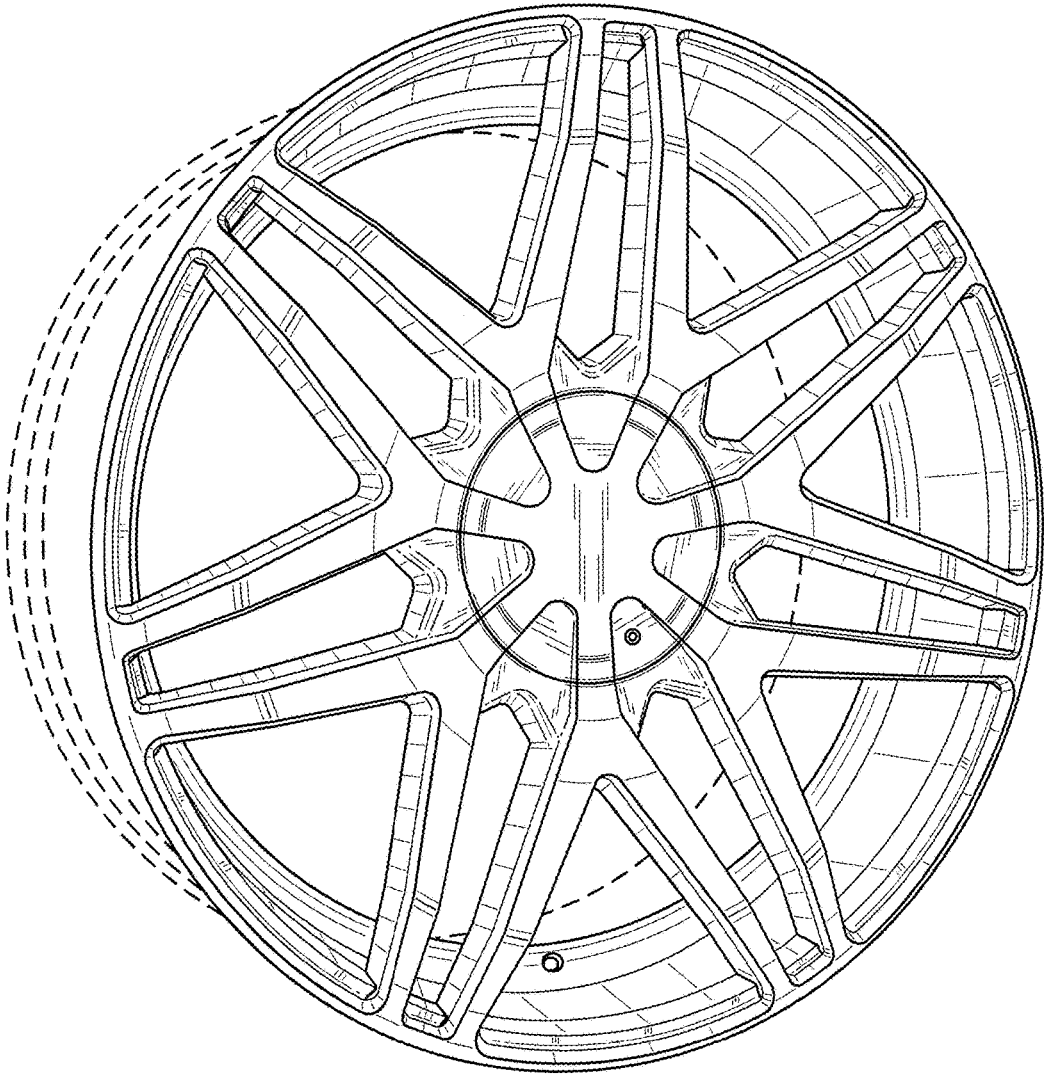

FIG. 1

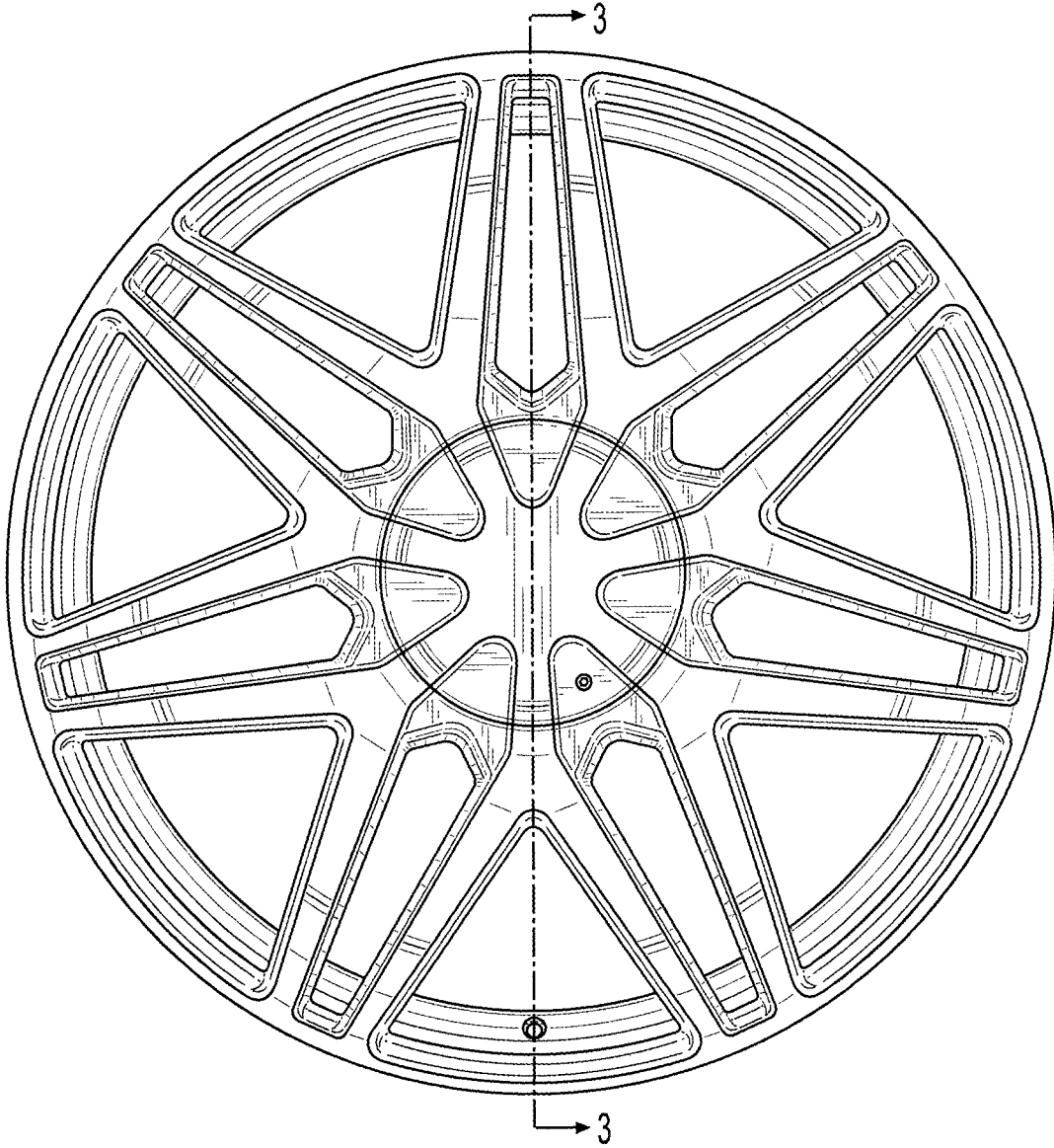

FIG. 2

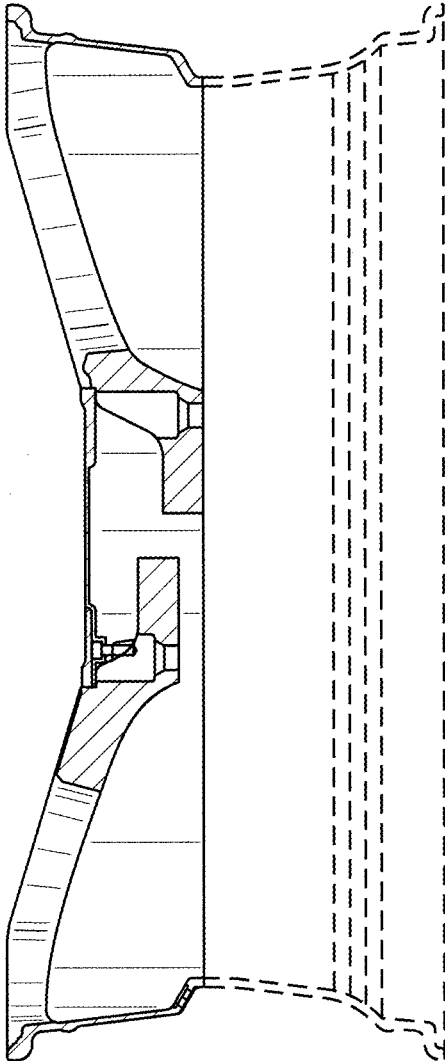

FIG. 3