

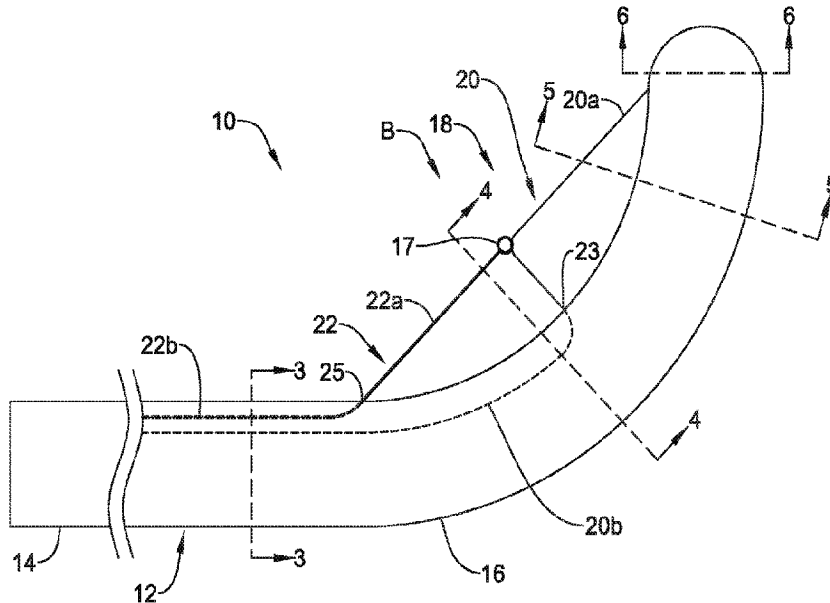

(86) **Date de dépôt PCT/PCT Filing Date:** 2019/06/10
 (87) **Date publication PCT/PCT Publication Date:** 2019/12/19
 (45) **Date de délivrance/Issue Date:** 2023/03/28
 (85) **Entrée phase nationale/National Entry:** 2020/11/20
 (86) **N° demande PCT/PCT Application No.:** US 2019/036390
 (87) **N° publication PCT/PCT Publication No.:** 2019/241154
 (30) **Priorités/Priorities:** 2018/06/11 (US62/683,318);
 2018/11/16 (US62/768,432)

(51) **Cl.Int./Int.Cl. A61B 17/3205** (2006.01),
A61B 18/00 (2006.01), **A61B 18/14** (2006.01),
A61B 18/16 (2006.01), **A61B 90/90** (2016.01)
 (72) **Inventeurs/Inventors:**
 WEITZNER, BARRY, US;
 SMITH, PAUL, US;
 DAYTON, PETER L., US;
 WILDER, EVAN, US
 (73) **Propriétaire/Owner:**
 BOSTON SCIENTIFIC SCIMED, INC., US
 (74) **Agent:** SMART & BIGGAR LP

(54) **Titre : SPHINCTEROTOMES ET PROCÉDES D'UTILISATION DE SPHINCTEROTOMES**
 (54) **Title: SPHINCTEROTOMES AND METHODS FOR USING SPHINCTEROTOMES**



(57) **Abrégé/Abstract:**

Sphincterotomes and methods for making and using sphincterotomes are disclosed. An example sphincterotome may include an elongate shaft having an outer surface and a distal end region. The sphincterotome may also include a sphincterotome wire assembly having a distal end coupled to the distal end region of the elongate shaft and a body portion extending along the outer surface of the elongate shaft. The sphincterotome wire assembly may be designed to shift the distal end region of the elongate shaft between a first configuration and a curved configuration. The body portion of the sphincterotome wire assembly may include a cutting region and a non-conductive region.

(12) INTERNATIONAL APPLICATION PUBLISHED UNDER THE PATENT COOPERATION TREATY (PCT)

(19) World Intellectual Property
 Organization
 International Bureau



(10) International Publication Number
WO 2019/241154 A1

(43) International Publication Date
 19 December 2019 (19.12.2019)

(51) International Patent Classification:

A61B 17/3205 (2006.01) *A61B 90/90* (2016.01)
A61B 18/14 (2006.01) *A61B 18/00* (2006.01)
A61B 18/16 (2006.01)

(21) International Application Number:

PCT/US2019/036390

(22) International Filing Date:

10 June 2019 (10.06.2019)

(25) Filing Language:

English

(26) Publication Language:

English

(30) Priority Data:

62/683,318 11 June 2018 (11.06.2018) US
 62/768,432 16 November 2018 (16.11.2018) US

(71) Applicant: **BOSTON SCIENTIFIC SCIMED, INC.**
 [US/US]; One Scimed Place, Maple Grove, Minnesota
 55311 (US).

(72) Inventors: **WEITZNER, Barry**; 3 MacLeod Lane, Acton, Massachusetts 01720 (US). **SMITH, Paul**; 45 Lakeside Drive, Smithfield, Rhode Island 02917 (US). **DAYTON, Peter L.**; 50 Winchester St, Apt. 401, Brookline, Massachusetts 02445 (US). **WILDER, Evan**; 82 Hummewell Ave, Boston, Massachusetts 02135 (US).

(74) Agent: **WICKHEM, J. Scot**; Seager, Tufts & Wickhem, LLP, 100 South 5th Street, Suite 600, Minneapolis, Minnesota 55402 (US).

(81) Designated States (unless otherwise indicated, for every kind of national protection available): AE, AG, AL, AM, AO, AT, AU, AZ, BA, BB, BG, BH, BN, BR, BW, BY, BZ, CA, CH, CL, CN, CO, CR, CU, CZ, DE, DJ, DK, DM, DO, DZ, EC, EE, EG, ES, FI, GB, GD, GE, GH, GM, GT, HN, HR, HU, ID, IL, IN, IR, IS, JO, JP, KE, KG, KH, KN, KP, KR, KW, KZ, LA, LC, LK, LR, LS, LU, LY, MA, MD, ME, MG, MK, MN, MW, MX, MY, MZ, NA, NG, NI, NO, NZ, OM, PA, PE, PG, PH, PL, PT, QA, RO, RS, RU, RW, SA,

(54) Title: SPHINCTEROTOMES AND METHODS FOR USING SPHINCTEROTOMES

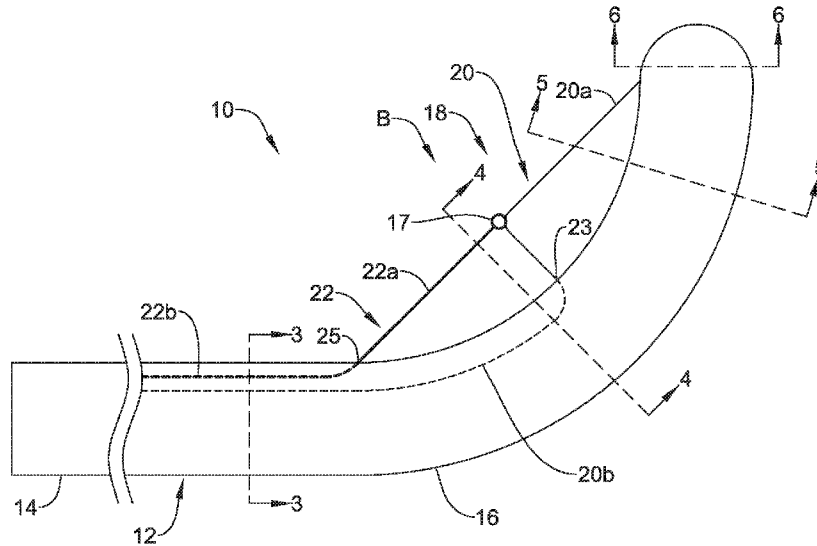

FIG. 2

(57) Abstract: Sphincterotomes and methods for making and using sphincterotomes are disclosed. An example sphincterotome may include an elongate shaft having an outer surface and a distal end region. The sphincterotome may also include a sphincterotome wire assembly having a distal end coupled to the distal end region of the elongate shaft and a body portion extending along the outer surface of the elongate shaft. The sphincterotome wire assembly may be designed to shift the distal end region of the elongate shaft between a first configuration and a curved configuration. The body portion of the sphincterotome wire assembly may include a cutting region and a non-conductive region.



WO 2019/241154 A1

WO 2019/241154 A1 

SC, SD, SE, SG, SK, SL, SM, ST, SV, SY, TH, TJ, TM, TN,
TR, TT, TZ, UA, UG, US, UZ, VC, VN, ZA, ZM, ZW.

- (84) Designated States** (*unless otherwise indicated, for every kind of regional protection available*): ARIPO (BW, GH, GM, KE, LR, LS, MW, MZ, NA, RW, SD, SL, ST, SZ, TZ, UG, ZM, ZW), Eurasian (AM, AZ, BY, KG, KZ, RU, TJ, TM), European (AL, AT, BE, BG, CH, CY, CZ, DE, DK, EE, ES, FI, FR, GB, GR, HR, HU, IE, IS, IT, LT, LU, LV, MC, MK, MT, NL, NO, PL, PT, RO, RS, SE, SI, SK, SM, TR), OAPI (BF, BJ, CF, CG, CI, CM, GA, GN, GQ, GW, KM, ML, MR, NE, SN, TD, TG).

Published:

- *with international search report (Art. 21(3))*

**SPHINCTEROTOMES AND METHODS FOR
USING SPHINCTEROTOMES**

Cross-Reference to Related Applications

[0001] This application claims priority to U.S. Provisional Application Serial No. 62/768,432, filed November 16, 2018 and U.S. Provisional Application Serial No. 62/683,318 filed June 11, 2018.

Technical Field

[0002] The present disclosure pertains to medical devices, and methods for manufacturing medical devices. More particularly, the present disclosure pertains to sphincterotomes.

Background

[0003] A wide variety of intracorporeal medical devices have been developed for medical use, for example, intravascular use. Some of these devices include guidewires, catheters, and the like. These devices are manufactured by any one of a variety of different manufacturing methods and may be used according to any one of a variety of methods. Of the known medical devices and methods, each has certain advantages and disadvantages. There is an ongoing need to provide alternative medical devices as well as alternative methods for manufacturing and using medical devices.

Brief Summary

[0004] This disclosure provides design, material, manufacturing method, and use alternatives for medical devices. A sphincterotome is disclosed. The sphincterotome comprises: an elongate shaft having an outer surface and a distal end region; a sphincterotome wire assembly having a distal end coupled to the distal end region of the elongate shaft and a body portion extending along the outer surface of the elongate shaft; wherein the sphincterotome wire assembly is designed to shift the distal end region of the elongate shaft between a first configuration and a curved configuration; and wherein the body portion of the sphincterotome wire assembly includes a cutting region and a non-conductive region.

[0005] Alternatively or additionally to any of the embodiments above, the cutting region of the sphincterotome wire assembly is defined by a conductive cutting wire.

[0006] Alternatively or additionally to any of the embodiments above, the non-conductive region of the sphincterotome wire assembly includes a non-conductive wire coupled to the conductive cutting wire.

[0007] Alternatively or additionally to any of the embodiments above, the non-conductive wire is coupled to the conductive cutting wire by a housing.

[0008] Alternatively or additionally to any of the embodiments above, the elongate shaft includes a distal anchor, wherein the distal end of the sphincterotome wire assembly is coupled to the distal end region of the elongate shaft at the distal anchor, and wherein the sphincterotome wire assembly includes a proximal region that extends through a port formed along the elongate shaft and into a lumen formed in the elongate shaft.

[0009] Alternatively or additionally to any of the embodiments above, the elongate shaft includes a proximal anchor, wherein the conductive cutting wire has a proximal end region coupled to the distal end region of the elongate shaft at the proximal anchor, and wherein the proximal anchor is disposed between the distal anchor and the port.

[0010] Alternatively or additionally to any of the embodiments above, the elongate shaft includes a distal port, and wherein the conductive cutting wire extends through the distal port and extends proximally within a lumen formed in the elongate shaft.

[0011] Alternatively or additionally to any of the embodiments above, the conductive cutting wire includes a conductive coating.

[0012] Alternatively or additionally to any of the embodiments above, the conductive cutting wire includes a cutting wire and a ground wire.

[0013] Alternatively or additionally to any of the embodiments above, the non-conductive region of the body portion of the sphincterotome wire assembly includes an insulating member coupled thereto.

[0014] Alternatively or additionally to any of the embodiments above, the elongate shaft includes an insulating projection and wherein the non-conductive region of the body portion of the sphincterotome wire assembly is coupled to the insulating projection.

[0015] Alternatively or additionally to any of the embodiments above, the insulating projection includes one or more of a flap, an opening, and a groove formed therein.

[0016] A sphincterotome is disclosed. The sphincterotome comprises: an elongate shaft having an outer surface, a distal end region, and a distal anchor disposed along the distal end region; a cutting wire coupled to the distal anchor and having a cutting region extending along the outer surface of the elongate shaft; a non-conductive cord coupled to the cutting region of the cutting wire and extending proximally therefrom; wherein the cutting wire, the non-conductive cord, or both are designed to shift the distal end region of the elongate shaft between a first configuration and a curved configuration.

[0017] Alternatively or additionally to any of the embodiments above, the non-conductive cord extends through a port formed in the elongate shaft and into a lumen formed in the elongate shaft.

[0018] Alternatively or additionally to any of the embodiments above, the cutting wire is coupled to the elongate shaft at a medial anchor, the medial anchor being disposed between the distal anchor and the port.

[0019] Alternatively or additionally to any of the embodiments above, the non-conductive cord is coupled to the cutting region of the cutting wire at a non-conductive housing.

[0020] Alternatively or additionally to any of the embodiments above, further comprising a ground wire coupled to the cutting wire.

[0021] A sphincterotome is disclosed. The sphincterotome comprises: an elongate shaft having a distal anchor, a projection formed in the elongate shaft and disposed proximally of the distal anchor; a cutting wire having a distal end coupled to the distal

anchor and a proximal region coupled to the projection; wherein the cutting wire is designed to shift the elongate shaft between a first configuration and a curved configuration; and wherein when the elongate shaft is in the curved configuration, at least a portion of the projection is radially spaced from an outer surface of the elongate shaft.

[0022] Alternatively or additionally to any of the embodiments above, the projection includes an insulating material.

[0023] Alternatively or additionally to any of the embodiments above, the projection has a channel formed therein.

[0023a] According to one aspect of the present invention, there is provided a sphincterotome, comprising: an elongate shaft having an outer surface and a distal end region; a sphincterotome wire assembly having a distal end coupled to the distal end region of the elongate shaft and a body portion extending along the outer surface of the elongate shaft; wherein the sphincterotome wire assembly is designed to shift the distal end region of the elongate shaft between a first configuration and a curved configuration; and wherein the body portion of the sphincterotome wire assembly includes a cutting region, a non-conductive region, and a joint disposed between and coupling the cutting region to the non-conductive region.

[0023b] According to another aspect of the present invention, there is provided a sphincterotome, comprising: an elongate shaft having an outer surface, a distal end region, and a distal anchor disposed along the distal end region; a cutting wire coupled to the distal anchor and having a cutting region extending along the outer surface of the elongate shaft; a non-conductive cord that is non-conductively coupled to the cutting region of the cutting wire and extending proximally therefrom; wherein the cutting wire, the non-conductive cord, or both are designed to shift the distal end region of the elongate shaft between a first configuration and a curved configuration.

[0024] The above summary of some embodiments is not intended to describe each disclosed embodiment or every implementation of the present disclosure. The Figures, and Detailed Description, which follow, more particularly exemplify these embodiments.

Brief Description of the Drawings

[0025] The disclosure may be more completely understood in consideration of the following detailed description in connection with the accompanying drawings, in which:

- [0026]** FIGS. 1-2 are side views of a portion of an example sphincterotome.
- [0027]** FIGS. 3-6 are cross-sectional views of the sphincterotome shown in FIGS. 1-2.
- [0028]** FIG. 7 is a side view of a portion of an example sphincterotome.
- [0029]** FIGS. 8-11 are cross-sectional views of the sphincterotome shown in FIG. 7.
- [0030]** FIG. 12 is a side view of a portion of an example sphincterotome.
- [0031]** FIGS. 13-16 are cross-sectional views of the sphincterotome shown in FIG. 12.

- [0032]** FIG. 17 is a side view of a portion of an example sphincterotome.
- [0033]** FIGS. 18-21 are cross-sectional views of the sphincterotome shown in FIG. 17.
- [0034]** FIG. 22 is a side view of a portion of an example sphincterotome.
- [0035]** FIGS. 23-26 are cross-sectional views of the sphincterotome shown in FIG. 22.
- [0036]** FIG. 27 is an alternative cross-section view of a portion of an example sphincterotome.
- [0037]** FIG. 28 is a side view of a portion of an example sphincterotome.
- [0038]** FIGS. 29-32 are cross-sectional views of the sphincterotome shown in FIG. 28.
- [0039]** FIG. 33 is a side view of a portion of an example sphincterotome.
- [0040]** FIGS. 34-37 are cross-sectional views of the sphincterotome shown in FIG. 33.
- [0041]** FIG. 38 is a side view of a portion of an example sphincterotome.
- [0042]** FIGS. 39-42 are cross-sectional views of the sphincterotome shown in FIG. 38.
- [0043]** FIG. 43 is a side view of a portion of an example sphincterotome.
- [0044]** FIGS. 44-47 are cross-sectional views of the sphincterotome shown in FIG. 43.
- [0045]** FIG. 48 is a side view of a portion of an example sphincterotome.
- [0046]** FIGS. 49-52 are cross-sectional views of the sphincterotome shown in FIG. 48.
- [0047]** FIG. 53 is a side view of a portion of an example sphincterotome.

[0048] FIGS. 54-57 are cross-sectional views of the sphincterotome shown in FIG. 53.

[0049] While the disclosure is amenable to various modifications and alternative forms, specifics thereof have been shown by way of example in the drawings and will be described in detail. It should be understood, however, that the intention is not to limit the invention to the particular embodiments described. On the contrary, the intention is to cover all modifications, equivalents, and alternatives falling within the spirit and scope of the disclosure.

Detailed Description

[0050] For the following defined terms, these definitions shall be applied, unless a different definition is given in the claims or elsewhere in this specification.

[0051] All numeric values are herein assumed to be modified by the term “about”, whether or not explicitly indicated. The term “about” generally refers to a range of numbers that one of skill in the art would consider equivalent to the recited value (e.g., having the same function or result). In many instances, the terms “about” may include numbers that are rounded to the nearest significant figure.

[0052] The recitation of numerical ranges by endpoints includes all numbers within that range (e.g. 1 to 5 includes 1, 1.5, 2, 2.75, 3, 3.80, 4, and 5).

[0053] As used in this specification and the appended claims, the singular forms “a”, “an”, and “the” include plural referents unless the content clearly dictates otherwise. As used in this specification and the appended claims, the term “or” is generally employed in its sense including “and/or” unless the content clearly dictates otherwise.

[0054] It is noted that references in the specification to “an embodiment”, “some embodiments”, “other embodiments”, etc., indicate that the embodiment described may include one or more particular features, structures, and/or characteristics. However, such recitations do not necessarily mean that all embodiments include the particular features, structures, and/or characteristics. Additionally, when particular features, structures, and/or characteristics are described in connection with one embodiment, it

should be understood that such features, structures, and/or characteristics may also be used connection with other embodiments whether or not explicitly described unless clearly stated to the contrary.

[0055] The following detailed description should be read with reference to the drawings in which similar elements in different drawings are numbered the same. The drawings, which are not necessarily to scale, depict illustrative embodiments and are not intended to limit the scope of the invention.

[0056] Endoscopic retrograde cholangiopancreatography (ERCP) may be utilized to diagnose and treat various disorders of the pancreaticobiliary system. A clinician may use a sphincterotome to cannulate the papillary orifice. The sphincterotome may have a number of features including a cutting wire for performing a sphincterotomy. When performing sphincterotomy, the distal portion of the cutting wire may be used for cutting tissue. The proximal portion of the wire, in general, may not serve a cutting function. Additionally, while performing sphincterotomy, the folds of the duodenal wall may come in contact with the proximal portion of the cutting wire, which could result in an ancillary tissue burn. Disclosed herein are sphincterotomes where the proximal portion of the cutting wire is designed to be non-conductive, insulated, and/or otherwise non-cutting.

[0057] FIGS. 1-2 illustrates an example sphincterotome 10. The sphincterotome 10 may include an elongate shaft 12 having a proximal end region 14 and a distal end region 16. The sphincterotome 10 may include a sphincterotome wire assembly 18. The sphincterotome wire assembly 18 may be designed to shift the distal end region 16 of the elongate shaft 12 between a first configuration (e.g., as depicted in FIG. 1) and a curved or bowed configuration (e.g., as depicted in FIG. 2). For example, exerting a proximal force on one or more of the components of the sphincterotome wire assembly 18 may cause the elongate shaft 12 to shift between configurations.

[0058] The sphincterotome wire assembly 18 may include a body portion B generally defined as the portion of the sphincterotome wire assembly 18 extending along the outer surface of the elongate shaft 12 and that may be described as extending

diagonally akin to the string of a bow when the elongate shaft 12 is in the curved configuration (e.g., as depicted in FIG. 2).

[0059] The sphincterotome wire assembly 18 may include a first member or portion 20 and a second member or portion 22. The first member 20 may be coupled to the second member 22 at a joint 17. In this example, the first member 20 may take the form of a wire having a cutting region 20a and a proximally-extending region 20b. A distal end region of the first member 20 may be anchored to the distal end region 16 of the shaft 12 (e.g., using, for example, a metallic anchor). A portion of the cutting region 20a of the first member 20 may be secured to or otherwise extend through a loop or opening defined at the joint 17 and then the first member 20 may extend generally toward the outer surface of the shaft 12. In some instances, the first member 20 may extend through a first port 23 formed in the shaft 12 and into a lumen of the shaft 12 (e.g., the second lumen 26 as shown, for example, in FIG. 3). The second member 22 may take the form of a wire or non-conductive cord (e.g., formed from a non-conductive material such as aramid) having a non-conductive region 22a and a proximally-extending region 22b. In some instances, a distal end region of the second member 22 may be secured to the joint 17. The second member 22 may extend through a second port 25 formed in the shaft 12 and into a lumen of the shaft 12 (e.g., the first lumen 24 as shown, for example, in FIG. 3). In at least some instances, the first port 23 may be disposed along the shaft 12 at a position between the location where the distal end region of the first member 20 is anchored to the shaft 12 and the second port 25. In other words, the first port 23 may be disposed between the distal anchor and the second port 25.

[0060] The body portion B of the sphincterotome wire assembly 18 may include the cutting region 20a of the first member 20 and the non-conductive region 22a of the second member 22. In at least some instances, the first member 20 is a conductive wire (e.g., an RF conductive wire) that can be energized. When doing so, the cutting region 20a may be energized so as to facilitate cutting. In contrast, the second member 22 may be non-conductive. Accordingly, the non-conductive region 22a may generally be described as being non-energized, non-cutting, and/or otherwise designed so as to not facilitate cutting.

[0061] FIGS. 3-6 are cross-sectional views taken at various locations along the shaft 12. Here it can be seen that the shaft 12 may include a number of different lumens. For example, the shaft 12 may include a first lumen 24, a second lumen 26, a third lumen 28, and a fourth lumen 30. In this example, the proximally-extending region 22b of the second member 22 may extend through the first lumen 24. The proximally-extending region 20b of the first member 20 may extend through the second lumen 26. The third lumen 28 may be used for infusing a fluid such as a contrast media. The fourth lumen 30 may be a guidewire lumen.

[0062] FIG. 7 illustrates another example sphincterotome 110 that may be similar in form and function to other sphincterotomes disclosed herein. The sphincterotome 110 includes a shaft 112 having a distal end region 116. The sphincterotome 110 may include a sphincterotome wire assembly 118. The sphincterotome wire assembly 118 may be designed to shift the distal end region 116 of the elongate shaft 112 between a first configuration and a curved or bowed configuration.

[0063] The sphincterotome wire assembly 118 may include a body portion B generally defined as the portion of the sphincterotome wire assembly 118 extending along the outer surface of the elongate shaft 112 and that may be described as extending diagonally akin to the string of a bow when the elongate shaft 112 is in the curved configuration. The sphincterotome wire assembly 118 may include a first member or portion 120 and a second member or portion 122. The first member 120 may be coupled to the second member 122 at a joint 117. In this example, the joint 117 may take the form of a non-conductive housing designed to be secured to both the first member 120 and the second member 122. This may include a mechanical or other type of connection. The first member 120 may take the form of a wire having a cutting region 120a and a proximally-extending region 120b. A distal end region of the first member 120 may extend through a first port 123 formed in the shaft 112 and into a lumen of the shaft 112 (e.g., the second lumen 126 as shown, for example, in FIG. 8). The second member 122 may take the form of a wire or non-conductive cord having a non-conductive region 122a and a proximally-extending region 122b. The second member 122 may extend through a second port 125 formed in the shaft 112 and into a lumen of the shaft 112 (e.g., the first lumen 124 as shown, for example, in FIG. 8).

[0064] The body portion B of the sphincterotome wire assembly 118 may include the cutting region 120a of the first member 120 and the non-conductive region 122a of the second member 122. In at least some instances, the first member 120 is a conductive wire (e.g., an RF conductive wire) that can be energized. When doing so, the cutting region 120a may be energized so as to facilitate cutting. In contrast, the second member 122 may be non-conductive. Accordingly, the non-conductive region 122a may generally be described as being non-energized, non-cutting, and/or otherwise designed so as to not facilitate cutting.

[0065] FIGS. 8-11 are cross-sectional views taken at various locations along the shaft 112. Here it can be seen that the shaft 112 may include a number of different lumens. For example, the shaft 112 may include a first lumen 124, a second lumen 126, a third lumen 128, and a fourth lumen 130. In this example, the proximally-extending region 122b of the second member 122 may extend through the first lumen 124. The proximally-extending region 120b of the first member 120 may extend through the second lumen 126. The third lumen 128 may be used for infusing a fluid such as a contrast media. The fourth lumen 130 may be a guidewire lumen.

[0066] FIG. 12 illustrates another example sphincterotome 210 that may be similar in form and function to other sphincterotomes disclosed herein. The sphincterotome 210 includes a shaft 212 having a distal end region 216. The sphincterotome 210 may include a sphincterotome wire assembly 218. The sphincterotome wire assembly 218 may be designed to shift the distal end region 216 of the elongate shaft 212 between a first configuration and a curved or bowed configuration.

[0067] The sphincterotome wire assembly 218 may include a body portion B generally defined as the portion of the sphincterotome wire assembly 218 extending along the outer surface of the elongate shaft 212 and that may be described as extending diagonally akin to the string of a bow when the elongate shaft 212 is in the curved configuration. The sphincterotome wire assembly 218 may include a first member or portion 220 and a second member or portion 222. The first member 220 may be coupled to the second member 222 at a joint 217. The first member 220 may take the form of a wire having a cutting region 220a and a proximally-extending region 220b. A distal end region of the first member 220 may extend through a first port 223 formed in the

shaft 212 and into a lumen of the shaft 212 (e.g., the second lumen 226 as shown, for example, in FIG. 13). The second member 222 may take the form of a wire or non-conductive cord having a non-conductive region 222a and a proximally-extending region 222b. The second member 222 may extend through a second port 225 formed in the shaft 212 and into a lumen of the shaft 212 (e.g., the first lumen 224 as shown, for example, in FIG. 13).

[0068] The body portion B of the sphincterotome wire assembly 218 may include the cutting region 220a of the first member 220 and the non-conductive region 222a of the second member 222. In at least some instances, the first member 220 is a wire having a conductive member 220c that can be energized. In some instances, the conductive member 220c takes the form of a conductive coating, a conductive paint, a conductive coil (e.g., surrounding the cutting region 220a), and/or the like. The cutting region 220a may be energized so as to facilitate cutting. In contrast, the second member 222 may be non-conductive. Accordingly, the non-conductive region 222a may generally be described as being non-energized, non-cutting, and/or otherwise designed so as to not facilitate cutting.

[0069] FIGS. 13-16 are cross-sectional views taken at various locations along the shaft 212. Here it can be seen that the shaft 212 may include a number of different lumens. For example, the shaft 212 may include a first lumen 224, a second lumen 226, a third lumen 228, and a fourth lumen 230. In this example, the proximally-extending region 222b of the second member 222 may extend through the first lumen 224. The proximally-extending region 220b of the first member 220 may extend through the second lumen 226. The third lumen 228 may be used for infusing a fluid such as a contrast media. The fourth lumen 230 may be a guidewire lumen.

[0070] FIG. 17 illustrates another example sphincterotome 310 that may be similar in form and function to other sphincterotomes disclosed herein. The sphincterotome 310 includes a shaft 312 having a distal end region 316. The sphincterotome 310 may include a sphincterotome wire assembly 318. The sphincterotome wire assembly 318 may be designed to shift the distal end region 316 of the elongate shaft 312 between a first configuration and a curved or bowed configuration.

[0071] The sphincterotome wire assembly 318 may include a body portion B generally defined as the portion of the sphincterotome wire assembly 318 extending along the outer surface of the elongate shaft 312 and that may be described as extending diagonally akin to the string of a bow when the elongate shaft 312 is in the curved configuration. The sphincterotome wire assembly 318 may include a first member or portion 320 and a second member or portion 322. The first member 320 may take the form of a wire having a cutting region 320a and a proximally-extending region 320b. A distal end region of the first member 320 may be anchored to the distal end region 316 of the shaft 312. The second member 322 may take the form of a protective mesh or sheath designed to cover and/or insulate a portion of the first member 320.

[0072] The body portion B of the sphincterotome wire assembly 318 may include the cutting region 320a of the first member 320 and at least a portion of the second member 322. The cutting region 320a may be energized so as to facilitate cutting. The second member 322 may be non-conductive and insulate a portion of the first member 320 in a manner so as to not facilitate cutting.

[0073] FIGS. 18-21 are cross-sectional views taken at various locations along the shaft 312. Here it can be seen that the shaft 312 may include a number of different lumens. For example, the shaft 312 may include a first lumen 324, a second lumen 328, and a third lumen 330. In this example, the proximally-extending region 320b of the first member 320 may extend through the first lumen 324. The second lumen 328 may be used for infusing a fluid such as a contrast media. The third lumen 330 may be a guidewire lumen.

[0074] FIG. 22 illustrates another example sphincterotome 410 that may be similar in form and function to other sphincterotomes disclosed herein. The sphincterotome 410 includes a shaft 412 having a distal end region 416. The sphincterotome 410 may include a sphincterotome wire assembly 418. The sphincterotome wire assembly 418 may be designed to shift the distal end region 416 of the elongate shaft 412 between a first configuration and a curved or bowed configuration.

[0075] The sphincterotome wire assembly 418 may include a body portion B generally defined as the portion of the sphincterotome wire assembly 418 extending

along the outer surface of the elongate shaft 412 and that may be described as extending diagonally akin to the string of a bow when the elongate shaft 412 is in the curved configuration. The sphincterotome wire assembly 418 may include a first member or portion 420 and a second member or portion 422. The first member 420 may take the form of a wire having a cutting region 420a and a proximally-extending region 420b. A distal end region of the first member 420 may be anchored to the distal end region 416 of the shaft 412. The second member 422 may take the form of a projection extending from the shaft 412. In general, the projection 422 is designed to cover and/or insulate a portion of the first member 420.

[0076] The body portion B of the sphincterotome wire assembly 418 may include the cutting region 420a of the first member 420 and at least a portion of the second member 422. The cutting region 420a may be energized so as to facilitate cutting. The second member 422 may be non-conductive and may cover and/or insulate a portion of the first member 420 in a manner so as to not facilitate cutting.

[0077] FIGS. 23-26 are cross-sectional views taken at various locations along the shaft 412. Here it can be seen that the shaft 412 may include a number of different lumens. For example, the shaft 412 may include a first lumen 424, a second lumen 428, and a third lumen 430. In this example, the proximally-extending region 420b of the first member 420 may extend through the first lumen 424. The second lumen 428 may be used for infusing a fluid such as a contrast media. The third lumen 430 may be a guidewire lumen.

[0078] FIG. 27 is an alternative cross-sectional view of a portion of the shaft 412. In this example, the projection 422' is formed as a cutout from the shaft 412. Thus, the shaft 412 includes a cutout region 427. In some instances, the projection 422' may have a shape that mirrors or resembles the shape of the cutout region 427. In other instances, the projection 422' may be formed as a cutout and then processed to have a generally smaller shape and/or thickness.

[0079] FIG. 28 illustrates another example sphincterotome 510 that may be similar in form and function to other sphincterotomes disclosed herein. The sphincterotome 510 includes a shaft 512 having a distal end region 516. The sphincterotome 510 may

include a sphincterotome wire assembly 518. The sphincterotome wire assembly 518 may be designed to shift the distal end region 516 of the elongate shaft 512 between a first configuration and a curved or bowed configuration.

[0080] The sphincterotome wire assembly 518 may include a body portion B generally defined as the portion of the sphincterotome wire assembly 518 extending along the outer surface of the elongate shaft 512 and that may be described as extending diagonally akin to the string of a bow when the elongate shaft 512 is in the curved configuration. The sphincterotome wire assembly 518 may include a first member or portion 520 and a second member or portion 522. The first member 520 may take the form of a wire having a cutting region 520a and a proximally-extending region 520b. A distal end region of the first member 520 may be anchored to the distal end region 516 of the shaft 512. The second member 522 may take the form of a projection extending from the shaft 512. The projection 522 may include an opening 522a through which the first member 520 may extend. In general, the projection 522 is designed to cover and/or insulate a portion of the first member 520. In some instances, the projection 522 may include a slot or groove (not shown) through which the first member 520 may extend.

[0081] The body portion B of the sphincterotome wire assembly 518 may include the cutting region 520a of the first member 520 and at least a portion of the second member 522. The cutting region 520a may be energized so as to facilitate cutting. The second member 522 may be non-conductive and may cover and/or insulate a portion of the first member 520 in a manner so as to not facilitate cutting.

[0082] FIGS. 29-32 are cross-sectional views taken at various locations along the shaft 512. Here it can be seen that the shaft 512 may include a number of different lumens. For example, the shaft 512 may include a first lumen 524, a second lumen 528, and a third lumen 530. In this example, the proximally-extending region 520b of the first member 520 may extend through the first lumen 524. The second lumen 528 may be used for infusing a fluid such as a contrast media. The third lumen 530 may be a guidewire lumen.

[0083] FIG. 33 illustrates another example sphincterotome 610 that may be similar in form and function to other sphincterotomes disclosed herein. The sphincterotome 610 includes a shaft 612 having a distal end region 616. The sphincterotome 610 may include a sphincterotome wire assembly 618. The sphincterotome wire assembly 618 may be designed to shift the distal end region 616 of the elongate shaft 612 between a first configuration and a curved or bowed configuration.

[0084] The sphincterotome wire assembly 618 may include a body portion B generally defined as the portion of the sphincterotome wire assembly 618 extending along the outer surface of the elongate shaft 612 and that may be described as extending diagonally akin to the string of a bow when the elongate shaft 612 is in the curved configuration. The sphincterotome wire assembly 618 may include a first member or portion 620 and a second member or portion 622. The first member 620 may take the form of a wire having a cutting region 620a and a proximally-extending region 620b. A distal end region of the first member 620 may be anchored to the distal end region 616 of the shaft 612. The second member 622 may take the form of a projection formed by a cutout in the shaft 612. The projection 622 may include a groove 632 through which the first member 620 may extend. The shaft 612 may include a notch 623 corresponding to where the projection 622 is cut out from the shaft 612. In general, the projection 622 is designed to insulate a portion of the first member 620.

[0085] The body portion B of the sphincterotome wire assembly 618 may include the cutting region 620a of the first member 620 and at least a portion of the second member 622. The cutting region 620a may be energized so as to facilitate cutting. The second member 622 may be non-conductive and may cover and/or insulate a portion of the first member 620 in a manner so as to not facilitate cutting.

[0086] FIGS. 34-37 are cross-sectional views taken at various locations along the shaft 612. Here it can be seen that the shaft 612 may include a number of different lumens. For example, the shaft 612 may include a first lumen 624, a second lumen 628, and a third lumen 630. In this example, the proximally-extending region 620b of the first member 620 may extend through the first lumen 624. The second lumen 628 may be used for infusing a fluid such as a contrast media. The third lumen 630 may be a guidewire lumen.

[0087] FIG. 38 illustrates another example sphincterotome 710 that may be similar in form and function to other sphincterotomes disclosed herein. The sphincterotome 710 includes a shaft 712 having a distal end region 716. The sphincterotome 710 may include a sphincterotome wire assembly 718. The sphincterotome wire assembly 718 may be designed to shift the distal end region 716 of the elongate shaft 712 between a first configuration and a curved or bowed configuration.

[0088] The sphincterotome wire assembly 718 may include a body portion B generally defined as the portion of the sphincterotome wire assembly 718 extending along the outer surface of the elongate shaft 712 and that may be described as extending diagonally akin to the string of a bow when the elongate shaft 712 is in the curved configuration. The sphincterotome wire assembly 718 may include a first member or portion 720 and a second member or portion 722. The first member 720 and the second member 722 may be coupled to one another at a joint 717. In this example, the joint 717 may take the form of an insulated housing or spacer. The first member 720 may take the form of a bipolar wire assembly having a cutting region 720a and a proximally-extending region that includes a first wire region 720b (e.g., a conductive wire) and a second wire region 720c (e.g., a ground wire). An insulating medium 720d may be disposed between the first wire region 720b and the second wire region 720c. The first wire region 720b and the second wire region 720c may extend through ports formed in the shaft 712 into lumens of the shaft 712 (e.g., a second lumen 726a and a third lumen 726b as shown in FIG. 39). The second member 722 may take the form of a wire or non-conductive cord having a non-conductive region 722a and a proximally-extending region 722b. The second member 722 may extend through a second port 725 formed in the shaft 712 and into a lumen of the shaft 712 (e.g., the first lumen 724 as shown, for example, in FIG. 39).

[0089] The body portion B of the sphincterotome wire assembly 718 may include the cutting region 720a of the first member 720 and at least a portion of the second member 722. The cutting region 720a may be energized so as to facilitate cutting. The second member 722 may be non-conductive and insulate a portion of the first member 720 in a manner so as to not facilitate cutting.

[0090] FIGS. 39-42 are cross-sectional views taken at various locations along the shaft 712. Here it can be seen that the shaft 712 may include a number of different lumens. For example, the shaft 712 may include a first lumen 724, a second lumen 726a, a third lumen 726b, a fourth lumen 728, and a fifth lumen 730. In this example, the proximally-extending region 722b of the second member 722 may extend through the first lumen 724. The first wire region 720b and the second wire region 720c of the first member 720 may extend through the second lumen 726a and the third lumen 726b, respectively. The fourth lumen 728 may be used for infusing a fluid such as a contrast media. The fifth lumen 730 may be a guidewire lumen.

[0091] FIG. 43 illustrates another example sphincterotome 810 that may be similar in form and function to other sphincterotomes disclosed herein. The sphincterotome 810 includes a shaft 812 having a distal end region 816. The sphincterotome 810 may include a sphincterotome wire assembly 818. The sphincterotome wire assembly 818 may be designed to shift the distal end region 816 of the elongate shaft 812 between a first configuration and a curved or bowed configuration.

[0092] The sphincterotome wire assembly 818 may include a body portion B generally defined as the portion of the sphincterotome wire assembly 818 extending along the outer surface of the elongate shaft 812 and that may be described as extending diagonally akin to the string of a bow when the elongate shaft 812 is in the curved configuration. The sphincterotome wire assembly 818 may include a first member or portion 820 and a second member or portion 822. The first member 820 and the second member 822 may be coupled to one another at a joint 817. In this example, the joint 817 may take the form of an insulated housing. The first member 820 may take the form of a wire for delivering bipolar energy having a cutting region 820a and a proximally-extending region 820b. The first member 820 may extend through a first port 823 formed in the shaft 812 into a lumen of the shaft 812 (e.g., a second lumen 826 as shown in FIG. 43). The second member 822 may take the form of a wire or non-conductive cord having a non-conductive region 822a and a proximally-extending region 822b. The second member 822 may extend through a second port 825 formed in the shaft 812 and into a lumen of the shaft 812 (e.g., the first lumen 824 as shown, for example, in FIG. 43).

[0093] The body portion B of the sphincterotome wire assembly 818 may include the cutting region 820a of the first member 820 and at least a portion of the second member 822. The cutting region 820a may be energized so as to facilitate cutting. In contrast, the second member 822 may be non-conductive. Accordingly, the non-conductive region 822a may generally be described as being non-energized, non-cutting, and/or otherwise designed so as to not facilitate cutting. A ground pad 834, which may serve as the return for the cutting wire portion 820a, may be disposed along the distal end region 816 of the shaft 812. A ground wire 836 may be coupled to the ground pad 834.

[0094] FIGS. 44-47 are cross-sectional views taken at various locations along the shaft 812. Here it can be seen that the shaft 812 may include a number of different lumens. For example, the shaft 812 may include a first lumen 824, a second lumen 826, a third lumen 828, a fourth lumen 830, and a fifth lumen 838. In this example, the proximally-extending region 820b of the first member 820 may extend through the second lumen 826. The proximally-extending region 822b of the second member may extend through the first lumen 824. The third lumen 828 may be used for infusing a fluid such as a contrast media. The fourth lumen 830 may be a guidewire lumen. The ground wire 836 may extend through the fifth lumen 838.

[0095] FIG. 48 illustrates another example sphincterotome 910 that may be similar in form and function to other sphincterotomes disclosed herein. The sphincterotome 910 includes a shaft 912 having a distal end region 916. The sphincterotome 910 may include a sphincterotome wire assembly 918. The sphincterotome wire assembly 918 may be designed to shift the distal end region 916 of the elongate shaft 912 between a first configuration and a curved or bowed configuration.

[0096] The sphincterotome wire assembly 918 may include a body portion B generally defined as the portion of the sphincterotome wire assembly 918 extending along the outer surface of the elongate shaft 912 and that may be described as extending diagonally akin to the string of a bow when the elongate shaft 912 is in the curved configuration. The sphincterotome wire assembly 918 may include a first member or portion 920 and a second member or portion 922. The first member 920 may take the form of a wire having a cutting region 920a and a proximally-extending region 920b.

A distal end region of the first member 920 may be anchored to the distal end region 916 of the shaft 912.

[0097] The second member 922 may take the form of an external flap coupled to the shaft 912 (e.g., coupled via an adhesive bond, thermal bond, and/or the like). The second member 922 may be formed of a suitable material such as a polymer (e.g., polyetheretherketone and/or any suitable disclosed herein). The flap 622 may include a body region 929 disposed along the outer surface of the shaft 912, a projection region 931 extending from the body region 929, and an end region 933. The projection region 931 may have a suitable length such as about 1-20mm, or about 2-18mm, or about 5-15mm. In some instances, the projection region 931 may include a groove 932 (not shown in FIG. 48, can be seen in FIG. 50) through which the first member 920 may extend. In some of these and in other instances, the end region 933 may include or otherwise take the form of a loop or opening through which the first member 920 may extend.

[0098] The body portion B of the sphincterotome wire assembly 918 may include the cutting region 920a of the first member 920 and at least a portion of the second member 922 (e.g., the projection region 931). The cutting region 920a may be energized so as to facilitate cutting. The second member 922 may be non-conductive and may cover and/or insulate a portion of the first member 920 in a manner so as to not facilitate cutting. More particularly, the projection region 931 (and/or the second member 922) may be designed to insulate a portion of the first member 920.

[0099] It can be appreciated that the length of the first member 920 that is exposed or otherwise not covered/insulated by the projection region 931 can vary depending on the extent to which the shaft 912 is curved. For example, a clinician may be able to curve the shaft 912 to a relative small extent. When doing so, only a relatively small proportion of the length of the first member 920 may be covered/insulated by the projection region 931. Further curving the shaft 912 may shorten the overall length of the first member 920 along the body region B and increase the proportion of the length of the first member 920 that is covered/insulated by the projection region 931. This allows a clinician to vary the length of the first member 920 available for cutting, which

may be desirable in order to tailor the sphincterotome 910 for a number of different interventions.

[0100] FIGS. 49-52 are cross-sectional views taken at various locations along the shaft 912. Here it can be seen that the shaft 912 may include a number of different lumens. For example, the shaft 912 may include a first lumen 924, a second lumen 928, and a third lumen 930. In this example, the proximally-extending region 920b of the first member 920 may extend through the first lumen 924. The second lumen 928 may be used for infusing a fluid such as a contrast media. The third lumen 930 may be a guidewire lumen.

[0101] FIG. 53 illustrates another example sphincterotome 1010 that may be similar in form and function to other sphincterotomes disclosed herein. The sphincterotome 1010 includes a shaft 1012 having a distal end region 1016. The sphincterotome 1010 may include a sphincterotome wire assembly 1018. The sphincterotome wire assembly 918 may be designed to shift the distal end region 1016 of the elongate shaft 1012 between a first configuration and a curved or bowed configuration.

[0102] The sphincterotome wire assembly 1018 may include a body portion B generally defined as the portion of the sphincterotome wire assembly 1018 extending along the outer surface of the elongate shaft 1012 and that may be described as extending diagonally akin to the string of a bow when the elongate shaft 1012 is in the curved configuration. The sphincterotome wire assembly 1018 may include a first member or wire 1020 having a cutting region 1020a and a proximally-extending region 1020b. A distal end region of the wire 1020 may be anchored to the distal end region 1016 of the shaft 1012. A plurality of different coatings may be disposed along the wire 1020. For example, a first coating 1035a may be disposed along a first portion (e.g., a more distal portion) of the wire 1020 and a second or coating 1035b may be disposed along a second portion (e.g., a more proximal portion) of the wire 1020. The first coating 1035a, the second coating 1035b, or both may be disposed along the wire 1020 using a suitable process. Some example processes that may be suitable include electroplating, sputter coating, dip coating, spray coating, other coating processes, and/or the like.

[0103] In some instances, the first coating 1035a may be a conductive coating. For example, the first coating 1035a may have a relatively high conductivity (e.g., on the order of about 1×10^6 Siemens/m or greater) and a relatively low resistivity (e.g., on the order of about 7×10^{-7} Ohms/m or less). In some instances, the first coating 1035a may include a metallic coating such as a gold coating. Other coatings are contemplated.

[0104] In some instances, the second coating 1035b may be a non-conductive or insulating coating that, in general, is designed to insulate a second portion of the wire 1020. For example, the second coating 1035b may have a relatively low conductivity (e.g., on the order of about 1×10^6 Siemens/m or less) and a relatively high resistivity (e.g., on the order of about 7×10^{-7} Ohms/m or greater). For example, the second coating 1035b may include a ceramic coating, a polymeric coating, metal oxide (e.g., such as aluminum oxide), a metal nitride, and/or the like.

[0105] The body portion B of the sphincterotome wire assembly 1018 may include the cutting region 1020a of the wire 1020. The cutting region 1020a may be energized so as to facilitate cutting. When doing so, the first coating 1035a can conduct energy to facilitate cutting. The second coating 1035b may be non-conductive and may cover and/or insulate the wire 1020 in a manner so as to not facilitate cutting. It can be appreciated that variations in the difference in conductivity between the first coating 1035a and the second coating 1035b may alter the cutting characteristics of the sphincterotome wire assembly 1018. For example, relatively large differences in conductivity between the first coating 1035a and the second coating 1035b may generate more aggressive tissue burns at positions more adjacent to the first coating 1035a and less aggressive tissue burns (e.g., or no tissue burns) at positions more adjacent to the second coating 1035b. Relatively small differences in conductivity between the first coating 1035a and the second coating 1035b may result in more evenly distributed burns along the sphincterotome wire assembly 1018. In some instances, the first coating 1035a, the second coating 1035b, or both may terminate adjacent to the outer surface of the shaft 1012.

[0106] FIGS. 54-57 are cross-sectional views taken at various locations along the shaft 1012. Here it can be seen that the shaft 1012 may include a number of different lumens. For example, the shaft 1012 may include a first lumen 1024, a second lumen

1028, and a third lumen 1030. In this example, the proximally-extending region 1020b of the first member 1020 may extend through the first lumen 1024. The second lumen 1028 may be used for infusing a fluid such as a contrast media. The third lumen 1030 may be a guidewire lumen. In other instances, the first coating 1035a, the second coating 1035b, or both may extend through the outer surface of the shaft 1012 and into a lumen of the shaft 1012. For example, the second coating 1035b may extend into the first lumen 1024.

[0107] The materials that can be used for the various components of sphincterotomes disclosed herein may include those commonly associated with medical devices. For simplicity purposes, the following discussion makes reference to the shaft 12. However, this is not intended to limit the devices and methods described herein, as the discussion may be applied to other devices and/or components of devices disclosed herein.

[0108] The shaft 12 may be made from a metal, metal alloy, polymer (some examples of which are disclosed below), a metal-polymer composite, ceramics, combinations thereof, and the like, or other suitable material. Some examples of suitable polymers may include polytetrafluoroethylene (PTFE), ethylene tetrafluoroethylene (ETFE), fluorinated ethylene propylene (FEP), polyoxymethylene (POM, for example, DELRIN® available from DuPont), perfluoroalkoxy alkane (PFA), polyether block ester, polyurethane (for example, Polyurethane 85A), polypropylene (PP), polyvinylchloride (PVC), polyether-ester (for example, ARNITEL® available from DSM Engineering Plastics), ether or ester based copolymers (for example, butylene/poly(alkylene ether) phthalate and/or other polyester elastomers such as HYTREL® available from DuPont), polyamide (for example, DURETHAN® available from Bayer or CRISTAMID® available from Elf Atochem), elastomeric polyamides, block polyamide/ethers, polyether block amide (PEBA, for example available under the trade name PEBAX®), ethylene vinyl acetate copolymers (EVA), silicones, polyethylene (PE), high-density polyethylene, low-density polyethylene, linear low density polyethylene (for example REXELL®), polyester, polybutylene terephthalate (PBT), polyethylene terephthalate (PET), polytrimethylene terephthalate, polyethylene naphthalate (PEN), polyetheretherketone

(PEEK), polyimide (PI), polyetherimide (PEI), polyphenylene sulfide (PPS), polyphenylene oxide (PPO), poly paraphenylene terephthalamide (for example, KEVLAR®), polysulfone, nylon, nylon-12 (such as GRILAMID® available from EMS American Grilon), perfluoro(propyl vinyl ether) (PFA), ethylene vinyl alcohol, polyolefin, polystyrene, epoxy, polyvinylidene chloride (PVdC), poly(styrene-*b*-isobutylene-*b*-styrene) (for example, SIBS and/or SIBS 50A), polycarbonates, ionomers, biocompatible polymers, other suitable materials, or mixtures, combinations, copolymers thereof, polymer/metal composites, and the like. In some embodiments the sheath can be blended with a liquid crystal polymer (LCP). For example, the mixture can contain up to about 6 percent LCP.

[0109] Some examples of suitable metals and metal alloys include stainless steel, such as 304V, 304L, and 316LV stainless steel; mild steel; nickel-titanium alloy such as linear-elastic and/or super-elastic nitinol; other nickel alloys such as nickel-chromium-molybdenum alloys (e.g., UNS: N06625 such as INCONEL® 625, UNS: N06022 such as HASTELLOY® C-22®, UNS: N10276 such as HASTELLOY® C276®, other HASTELLOY® alloys, and the like), nickel-copper alloys (e.g., UNS: N04400 such as MONEL® 400, NICKELVAC® 400, NICORROS® 400, and the like), nickel-cobalt-chromium-molybdenum alloys (e.g., UNS: R30035 such as MP35-N® and the like), nickel-molybdenum alloys (e.g., UNS: N10665 such as HASTELLOY® ALLOY B2®), other nickel-chromium alloys, other nickel-molybdenum alloys, other nickel-cobalt alloys, other nickel-iron alloys, other nickel-copper alloys, other nickel-tungsten or tungsten alloys, and the like; cobalt-chromium alloys; cobalt-chromium-molybdenum alloys (e.g., UNS: R30003 such as ELGILOY®, PHYNOX®, and the like); platinum enriched stainless steel; titanium; combinations thereof; and the like; or any other suitable material.

[0110] In at least some embodiments, portions or all of the sphincterotome 10 may also be doped with, made of, or otherwise include a radiopaque material. Radiopaque materials are understood to be materials capable of producing a relatively bright image on a fluoroscopy screen or another imaging technique during a medical procedure. This relatively bright image aids the user of the sphincterotome 10 in determining its location. Some examples of radiopaque materials can include, but are not limited to,

gold, platinum, palladium, tantalum, tungsten alloy, polymer material loaded with a radiopaque filler, and the like. Additionally, other radiopaque marker bands and/or coils may also be incorporated into the design of the sphincterotome 10 to achieve the same result.

[0111] In some embodiments, a degree of Magnetic Resonance Imaging (MRI) compatibility is imparted into the sphincterotome 10. For example, the sphincterotome 10, or portions thereof, may be made of a material that does not substantially distort the image and create substantial artifacts (e.g., gaps in the image). Certain ferromagnetic materials, for example, may not be suitable because they may create artifacts in an MRI image. The sphincterotome 10, or portions thereof, may also be made from a material that the MRI machine can image. Some materials that exhibit these characteristics include, for example, tungsten, cobalt-chromium-molybdenum alloys (e.g., UNS: R30003 such as ELGILOY®, PHYNOX®, and the like), nickel-cobalt-chromium-molybdenum alloys (e.g., UNS: R30035 such as MP35-N® and the like), nitinol, and the like, and others.

[0112] It should be understood that this disclosure is, in many respects, only illustrative. Changes may be made in details, particularly in matters of shape, size, and arrangement of steps without exceeding the scope of the disclosure. This may include, to the extent that it is appropriate, the use of any of the features of one example embodiment being used in other embodiments. The invention's scope is, of course, defined in the language in which the appended claims are expressed.

CLAIMS:

1. A sphincterotome, comprising:
an elongate shaft having an outer surface and a distal end region;
a sphincterotome wire assembly having a distal end coupled to the distal end region of the elongate shaft and a body portion extending along the outer surface of the elongate shaft;
wherein the sphincterotome wire assembly is designed to shift the distal end region of the elongate shaft between a first configuration and a curved configuration; and
wherein the body portion of the sphincterotome wire assembly includes a cutting region, a non-conductive region, and a joint disposed between and coupling the cutting region to the non-conductive region.
2. The sphincterotome of claim 1, wherein the cutting region of the sphincterotome wire assembly is defined by a conductive cutting wire.
3. The sphincterotome of claim 2, wherein the non-conductive region of the sphincterotome wire assembly includes a non-conductive wire coupled to the conductive cutting wire.
4. The sphincterotome of claim 3, wherein the joint includes a housing.
5. The sphincterotome of any one of claims 3-4, wherein the elongate shaft includes a distal anchor, wherein the distal end of the sphincterotome wire assembly is coupled to the distal end region of the elongate shaft at the distal anchor, and wherein the sphincterotome wire assembly includes a proximal region that extends through a port formed along the elongate shaft and into a lumen formed in the elongate shaft.
6. The sphincterotome of claim 5, wherein the elongate shaft includes a proximal anchor, wherein the conductive cutting wire has a proximal end region coupled to the distal end region of the elongate shaft at the proximal anchor, and wherein the proximal anchor is disposed between the distal anchor and the port.

7. The sphincterotome of claim 2, wherein the elongate shaft includes a distal port, and wherein the conductive cutting wire extends through the distal port and extends proximally within a lumen formed in the elongate shaft.

8. The sphincterotome of claim 7, wherein the conductive cutting wire includes a conductive coating.

9. The sphincterotome of claim 2, wherein the conductive cutting wire includes a cutting wire and a ground wire.

10. The sphincterotome of any one of claims 1-9, wherein the non-conductive region of the body portion of the sphincterotome wire assembly includes an insulating member coupled thereto.

11. The sphincterotome of any one of claims 1-10, wherein the elongate shaft includes an insulating projection and wherein the non-conductive region of the body portion of the sphincterotome wire assembly is coupled to the insulating projection.

12. The sphincterotome of claim 11, wherein the insulating projection includes one or more of a flap, an opening, and a groove formed therein.

13. A sphincterotome, comprising:
an elongate shaft having an outer surface, a distal end region, and a distal anchor disposed along the distal end region;
a cutting wire coupled to the distal anchor and having a cutting region extending along the outer surface of the elongate shaft;
a non-conductive cord that is non-conductively coupled to the cutting region of the cutting wire and extending proximally therefrom;
wherein the cutting wire, the non-conductive cord, or both are designed to shift the distal end region of the elongate shaft between a first configuration and a curved configuration.

14. The sphincterotome of claim 13, wherein the non-conductive cord extends through a port formed in the elongate shaft and into a lumen formed in the elongate shaft.

15. The sphincterotome of claim 14, wherein the cutting wire is coupled to the elongate shaft at a medial anchor, the medial anchor being disposed between the distal anchor and the port.

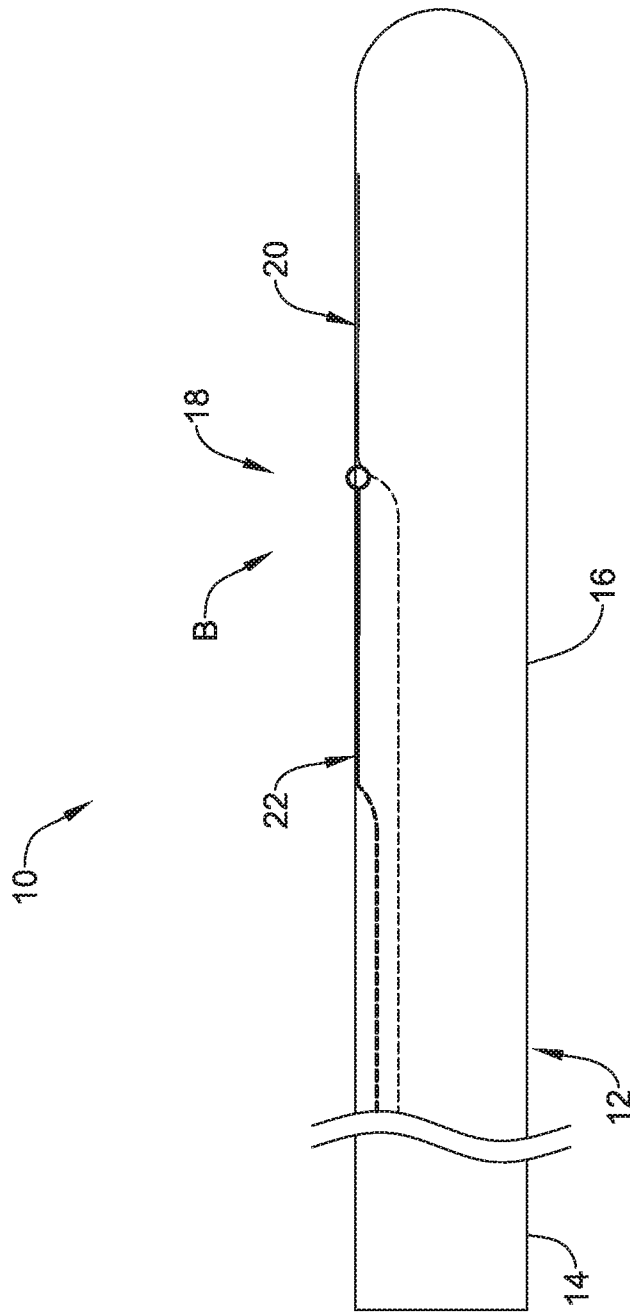

FIG. 1

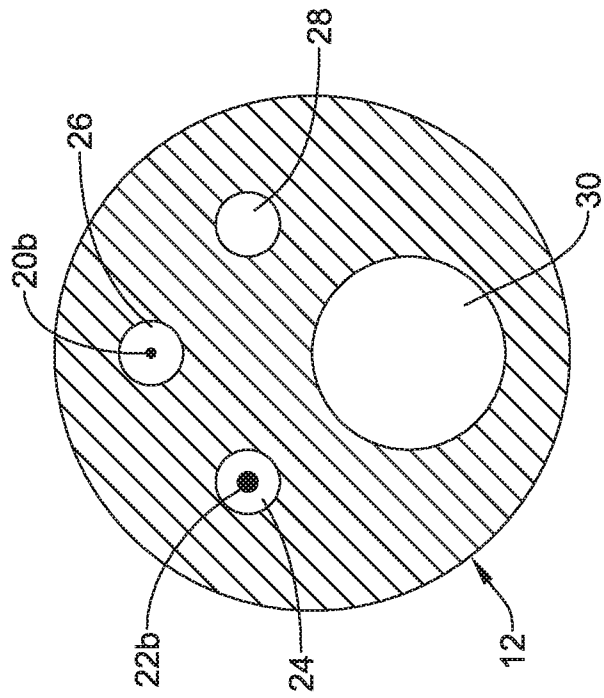

FIG. 3

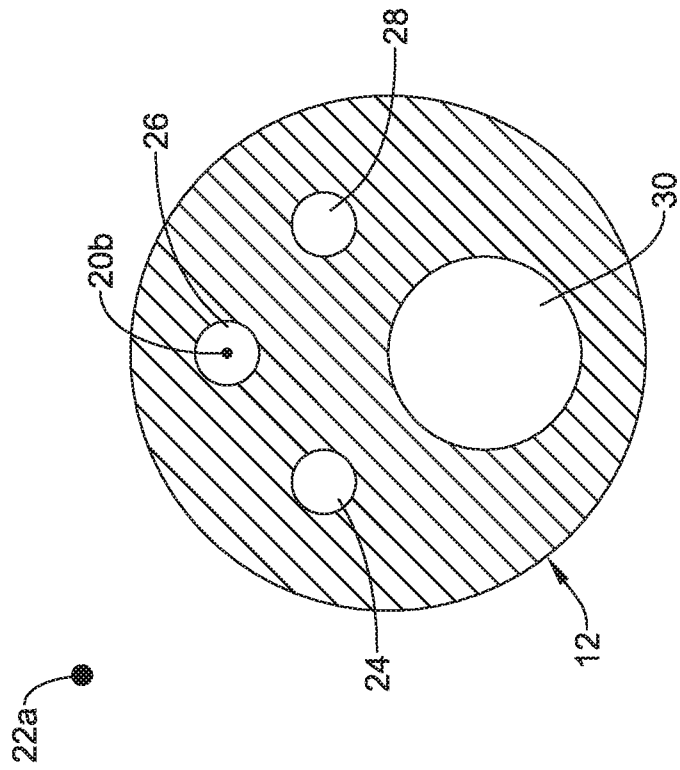

FIG. 4

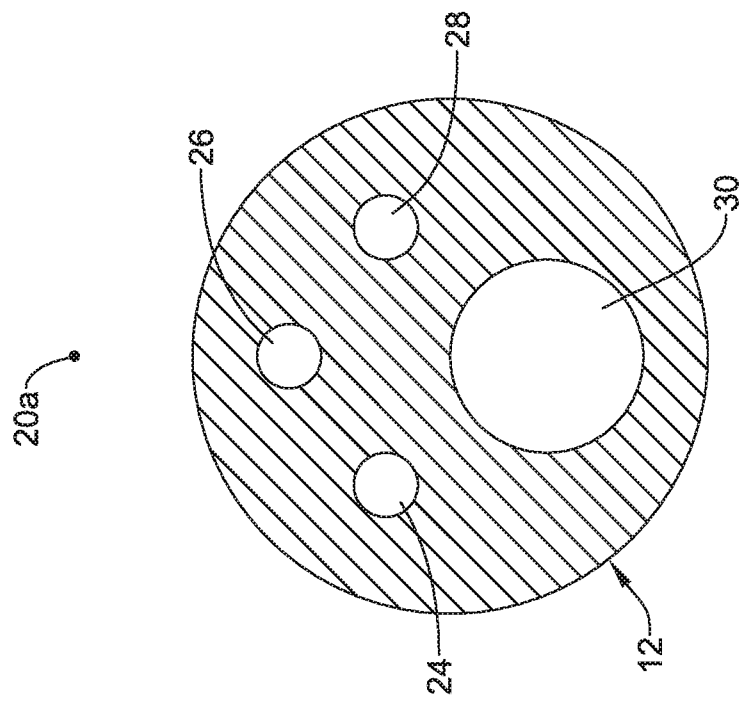

FIG. 5

6 / 57

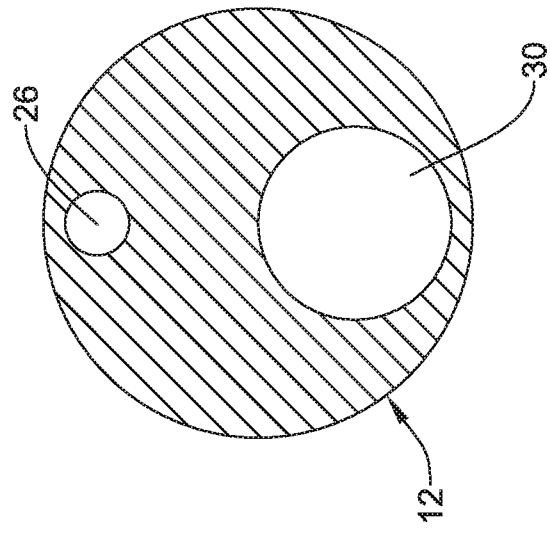

FIG. 6

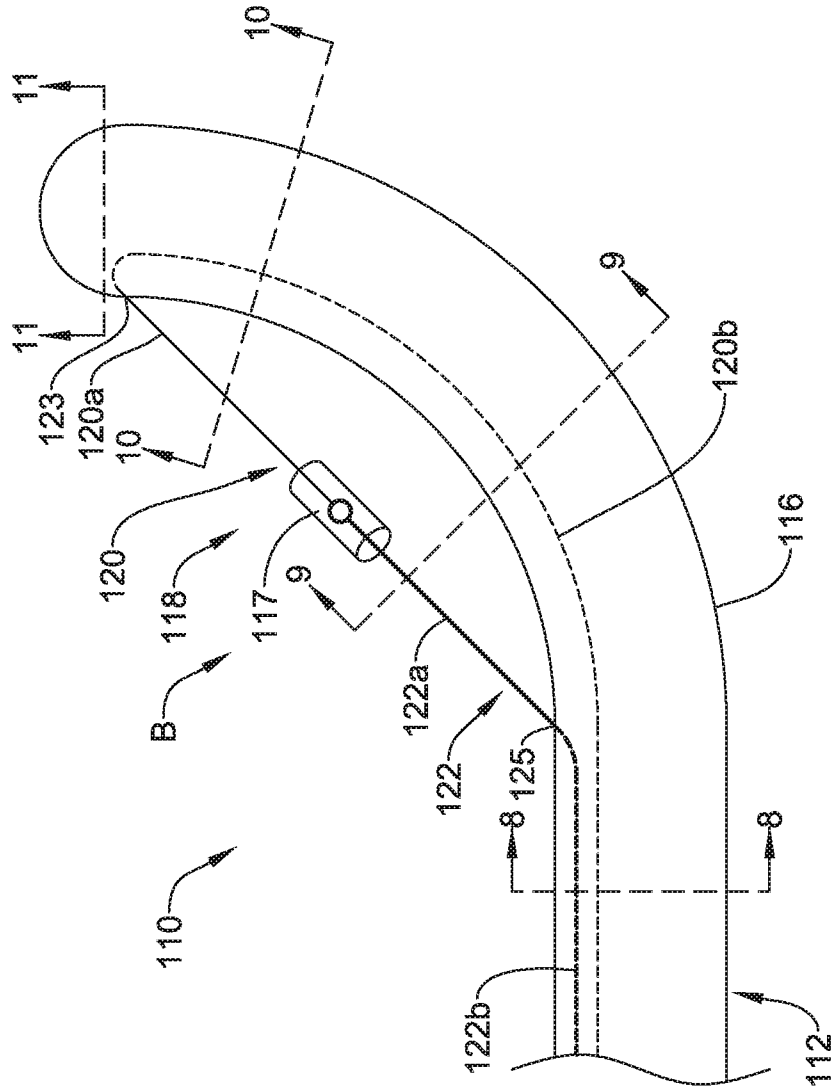

FIG. 7

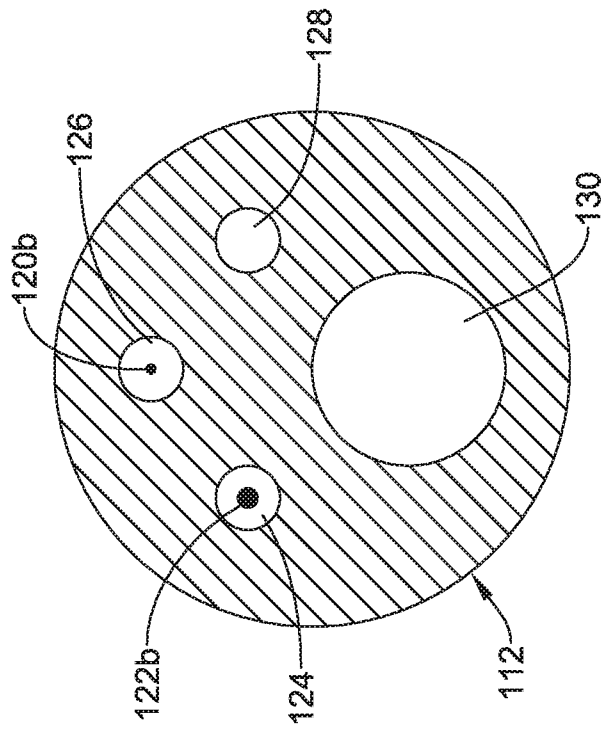

FIG. 8

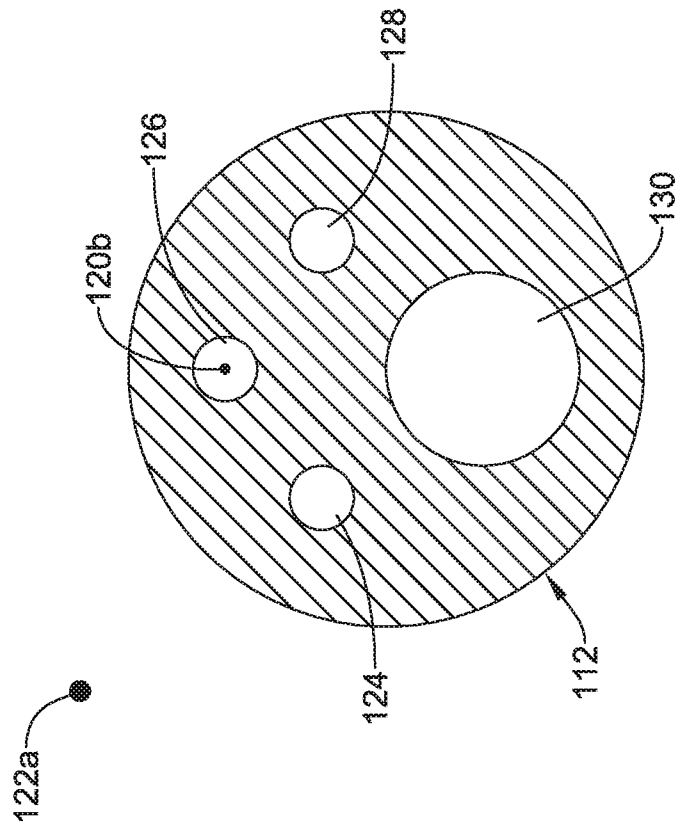

FIG. 9

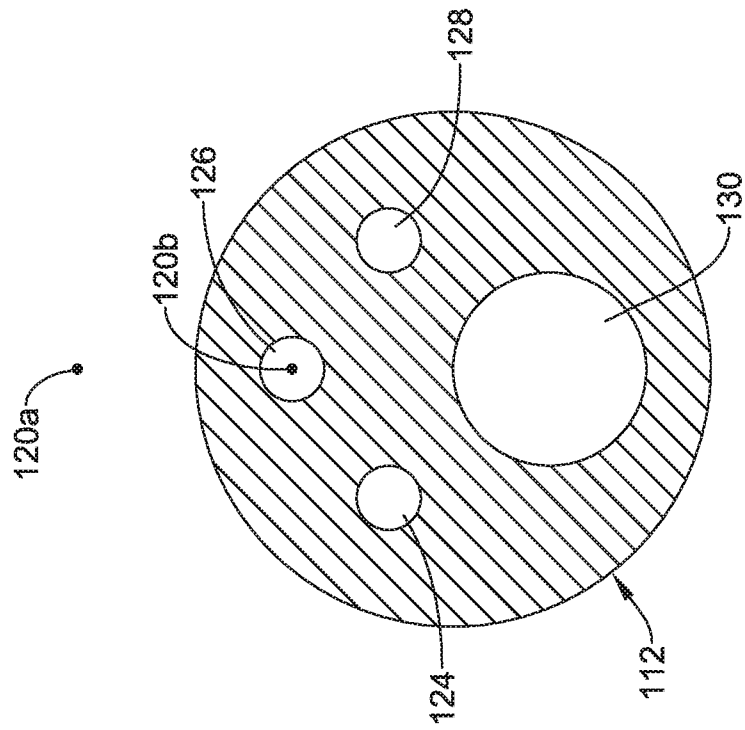

FIG. 10

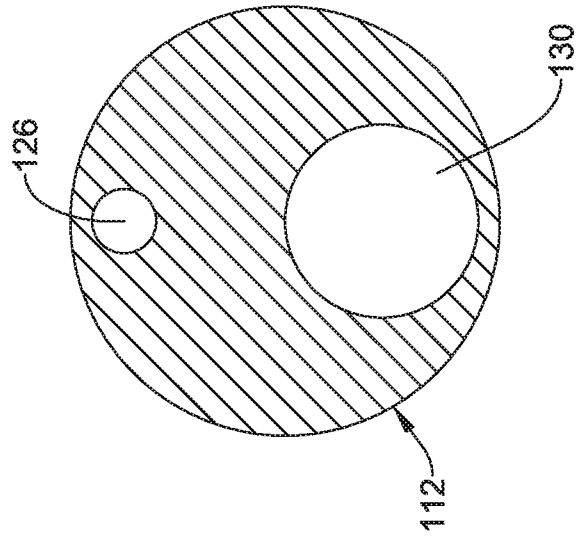

FIG. 11

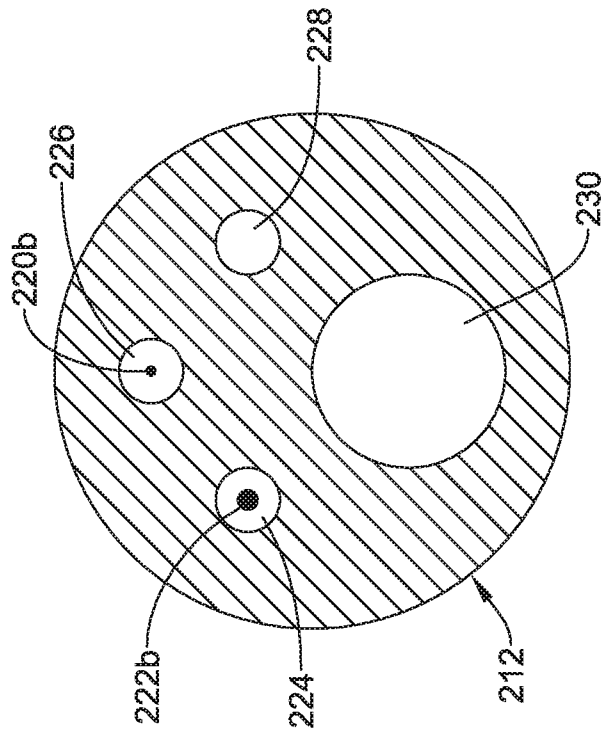

FIG. 13

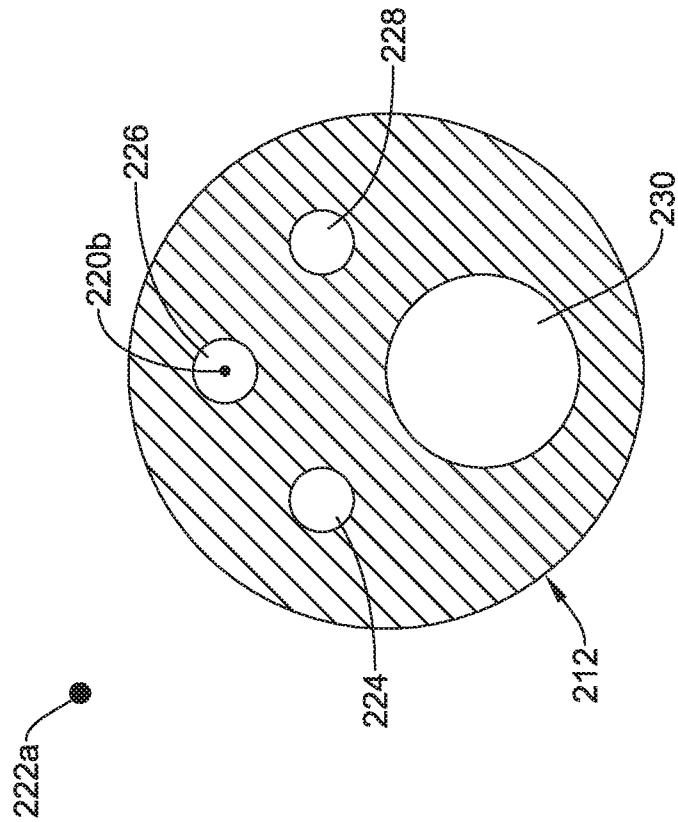

FIG. 14

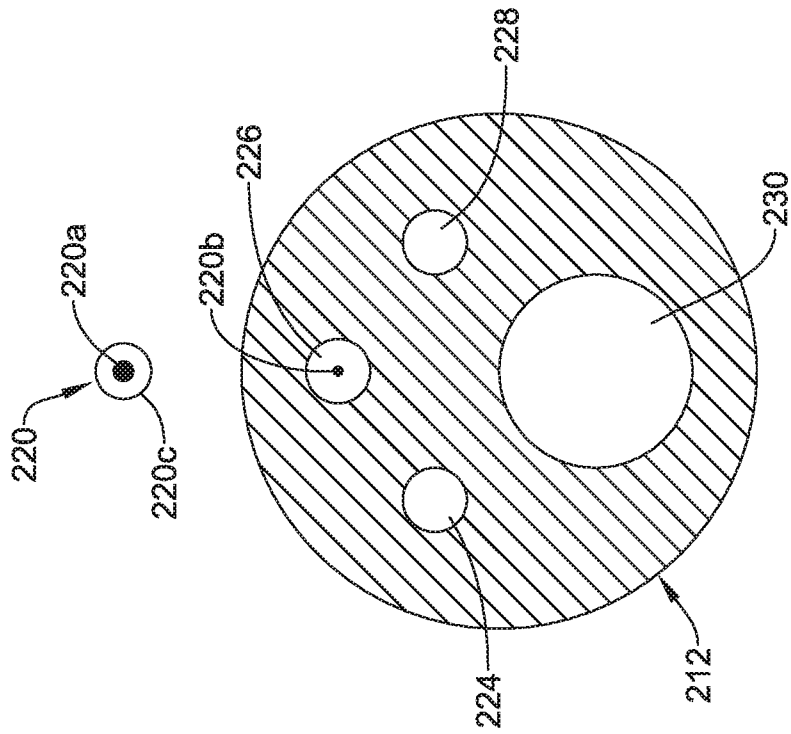

FIG. 15

16 / 57

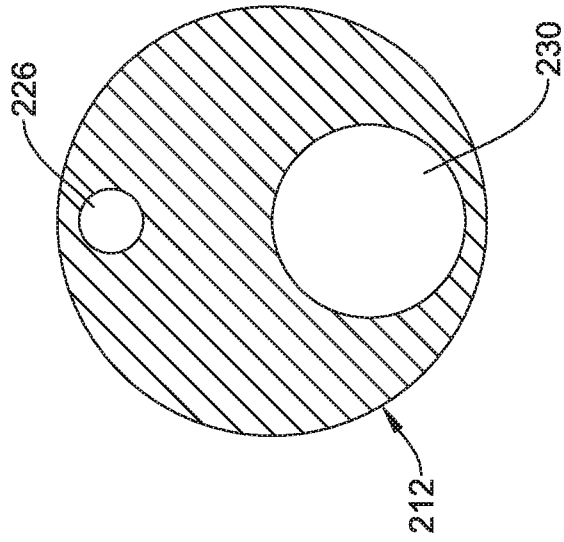

FIG. 16

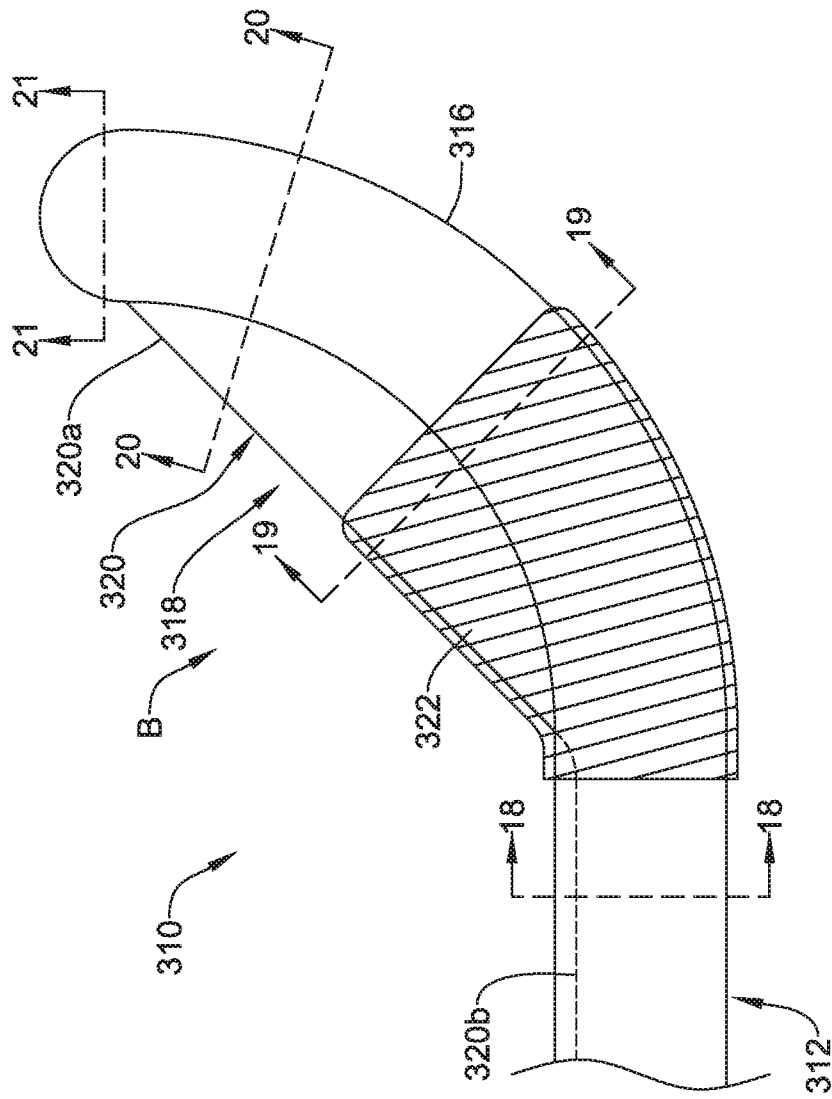

FIG. 17

18 / 57

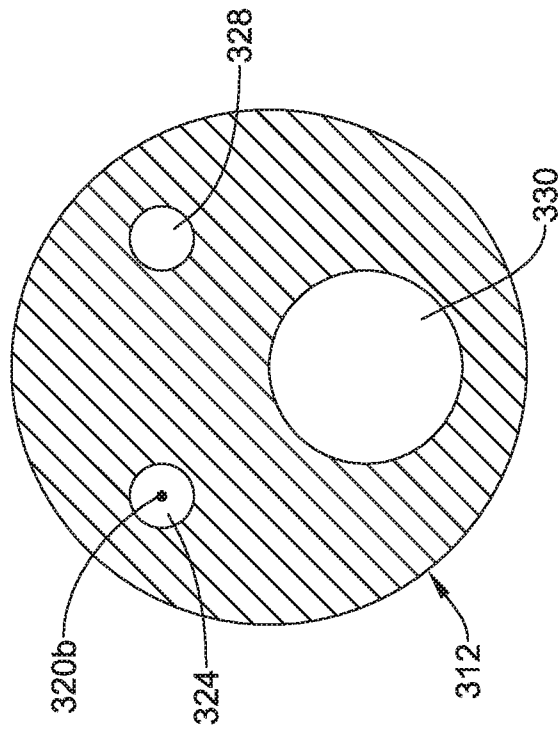

FIG. 18

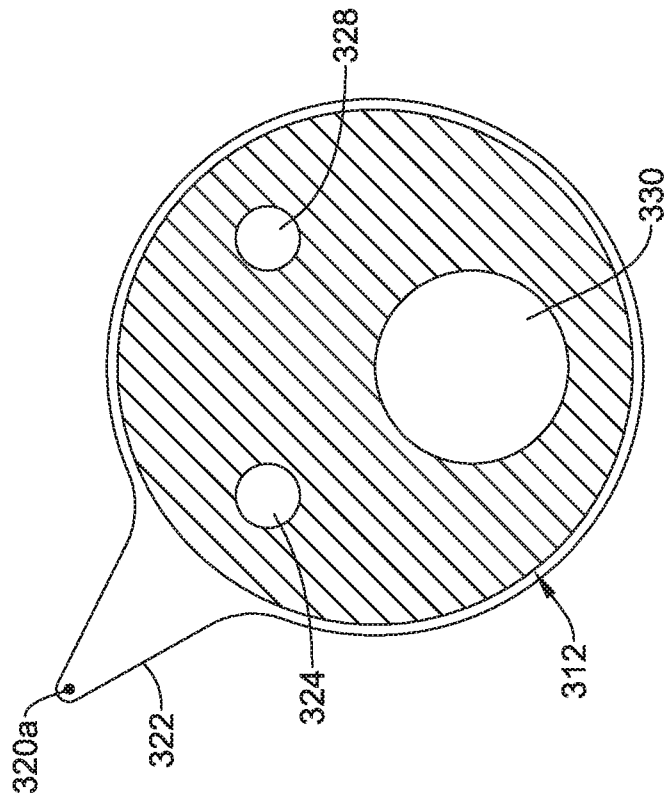

FIG. 19

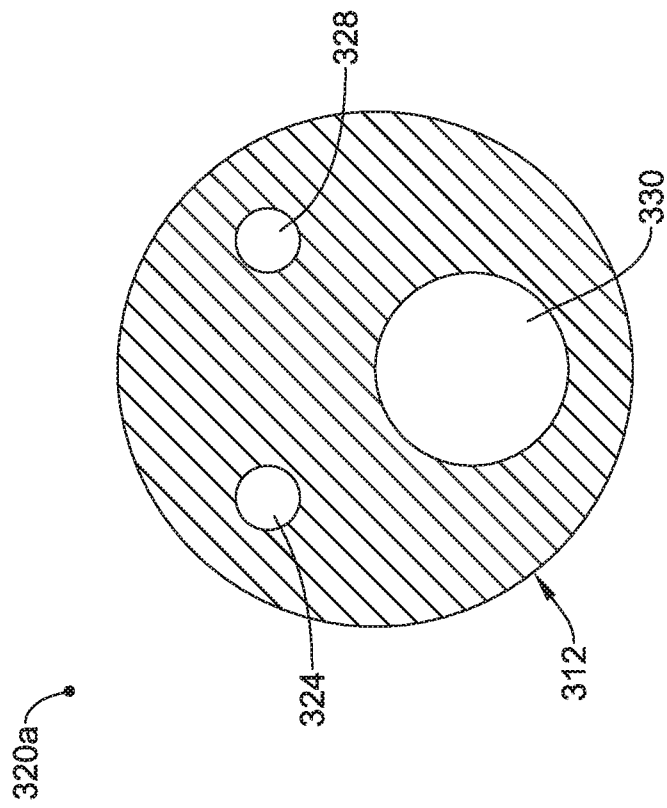

FIG. 20

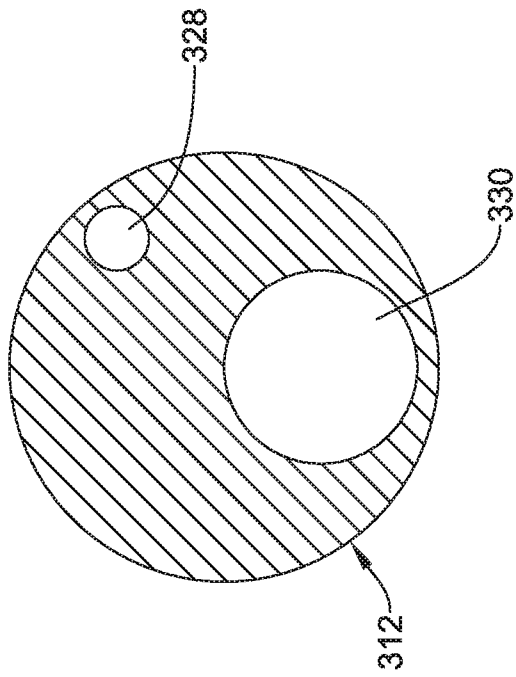

FIG. 21

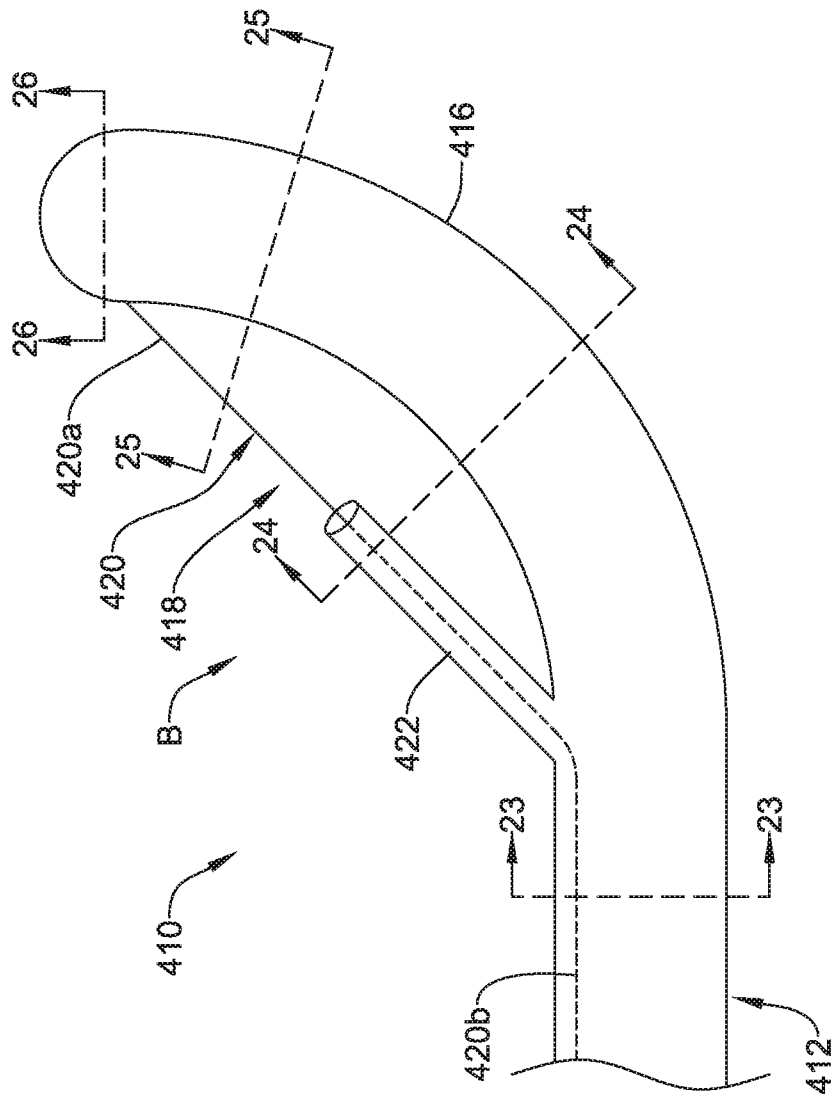

FIG. 22

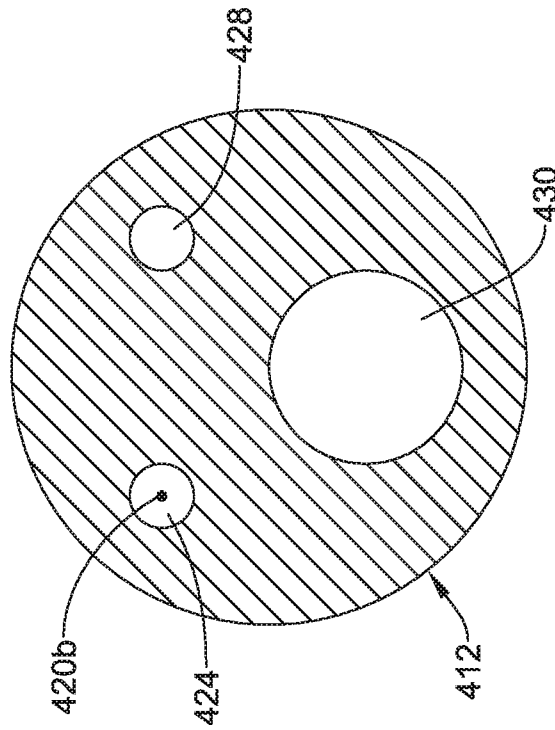

FIG. 23

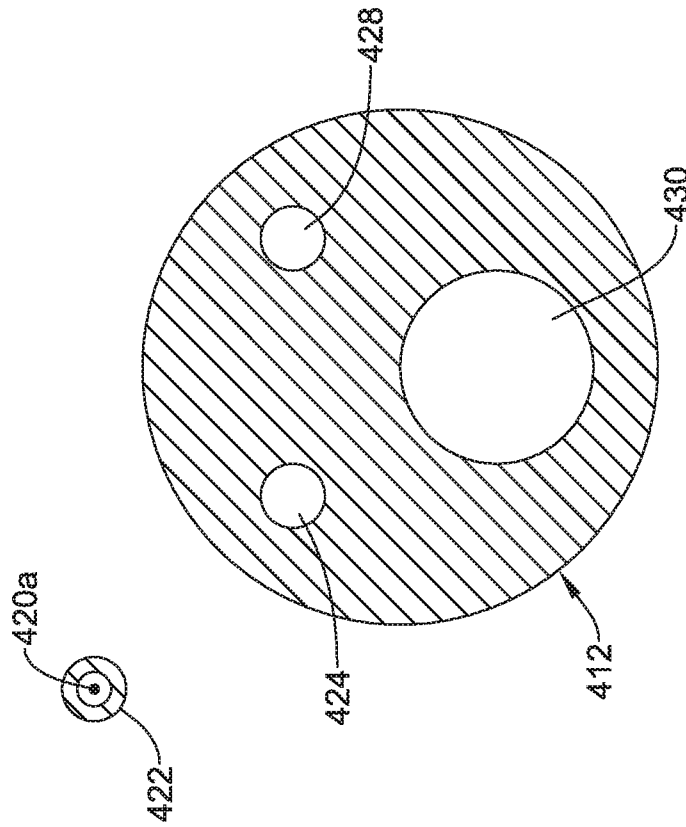

FIG. 24

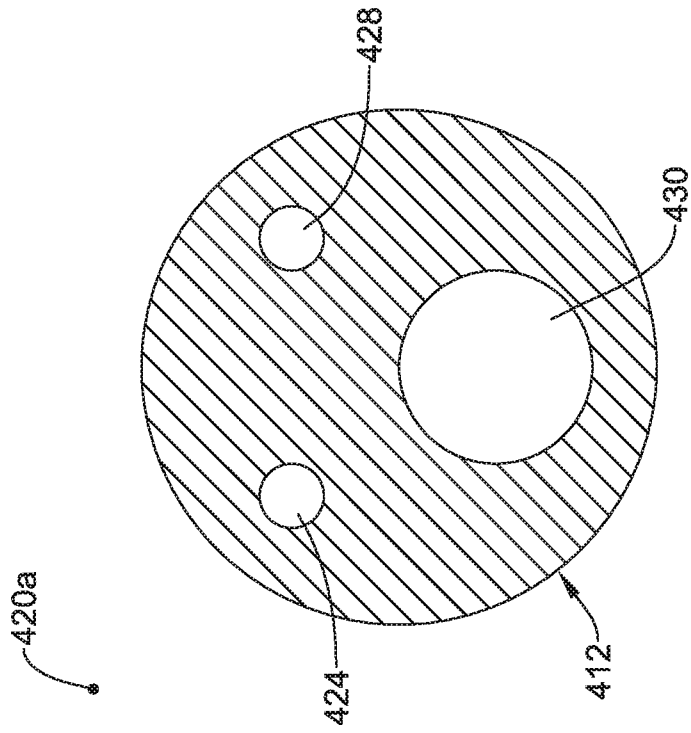

FIG. 25

26 / 57

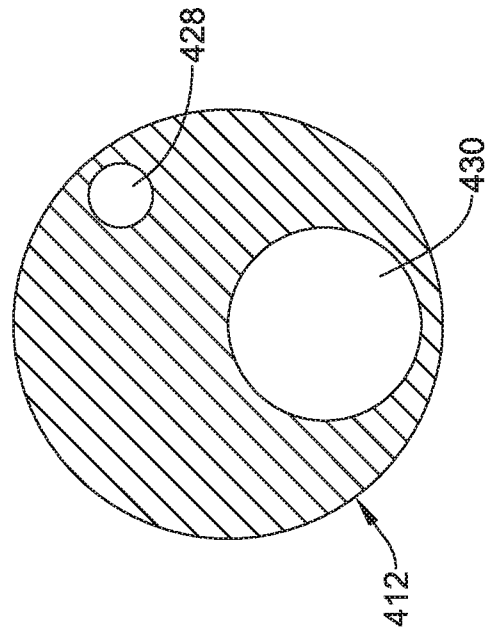

FIG. 26

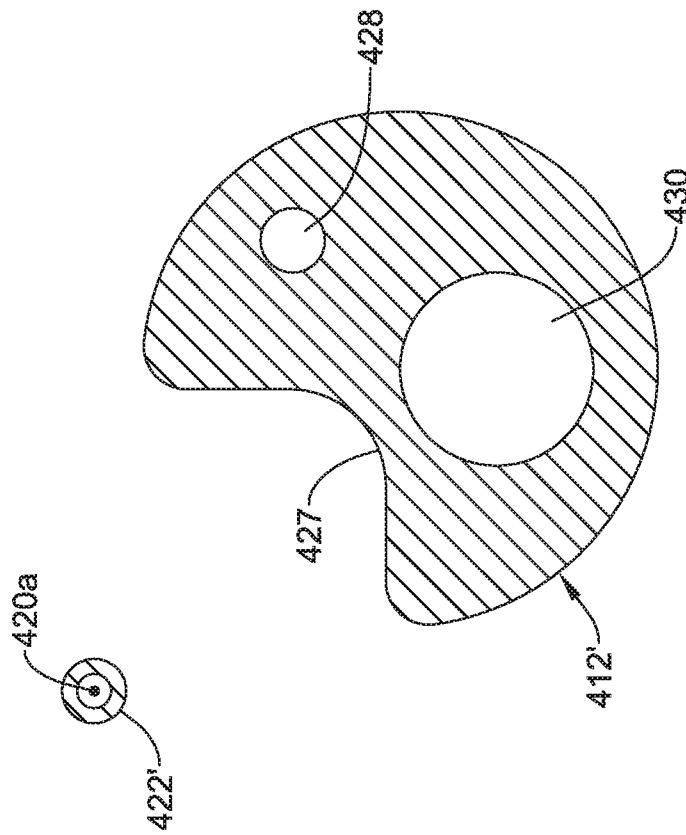

FIG. 27

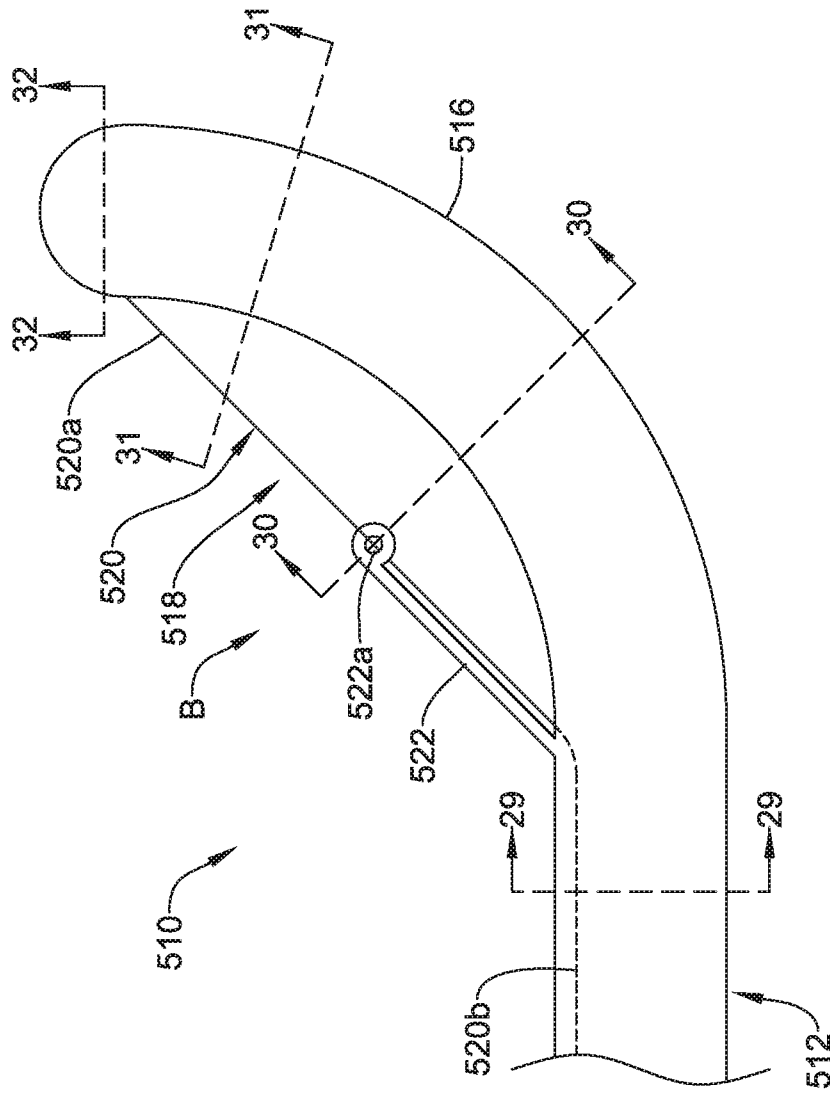

FIG. 28

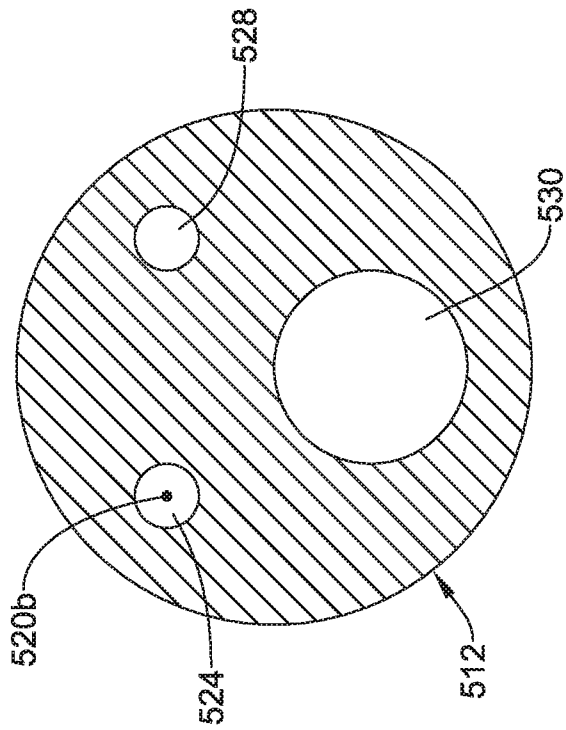

FIG. 29

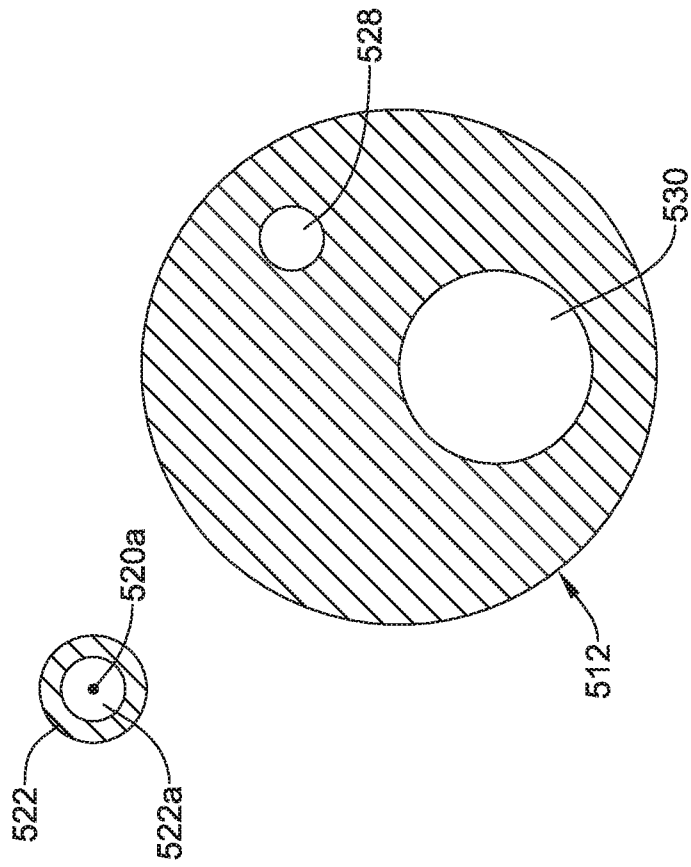

FIG. 30

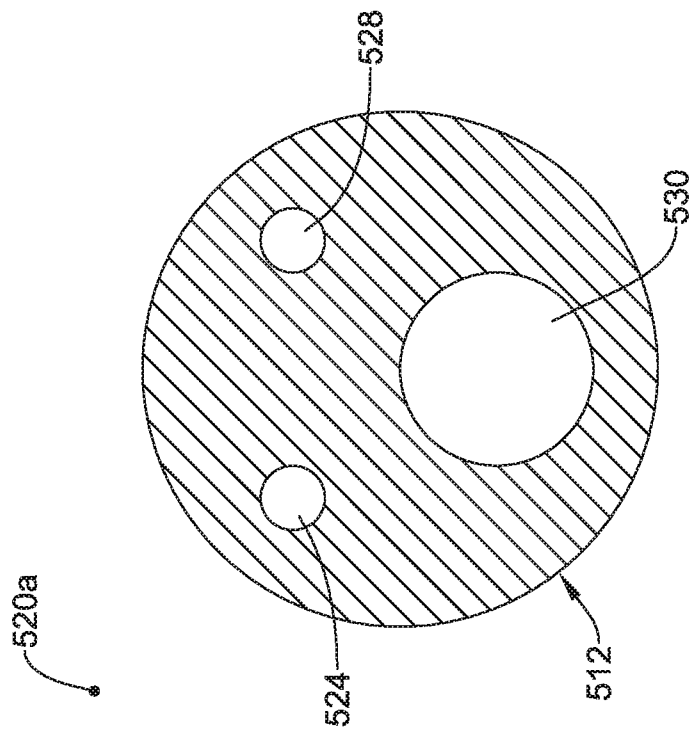

FIG. 31

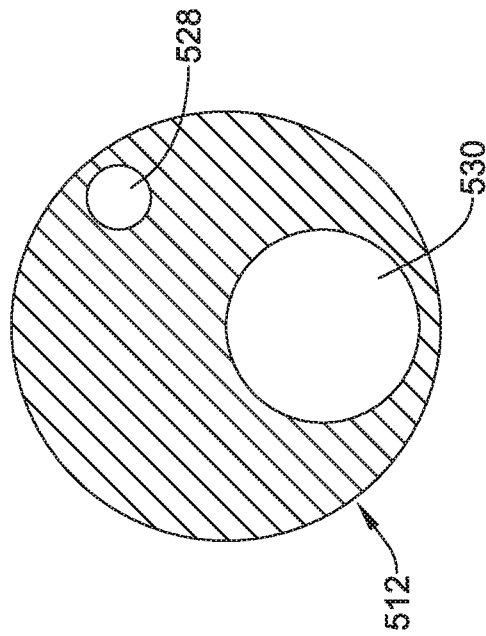

FIG. 32

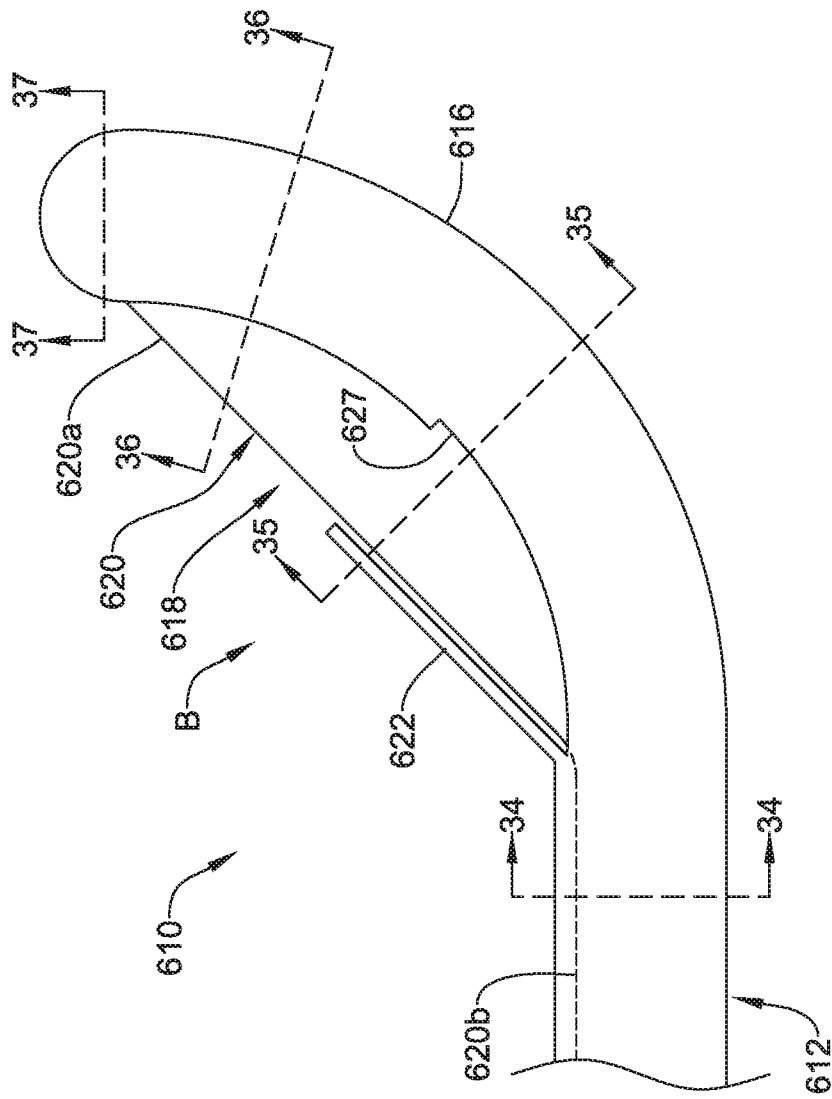

FIG. 33

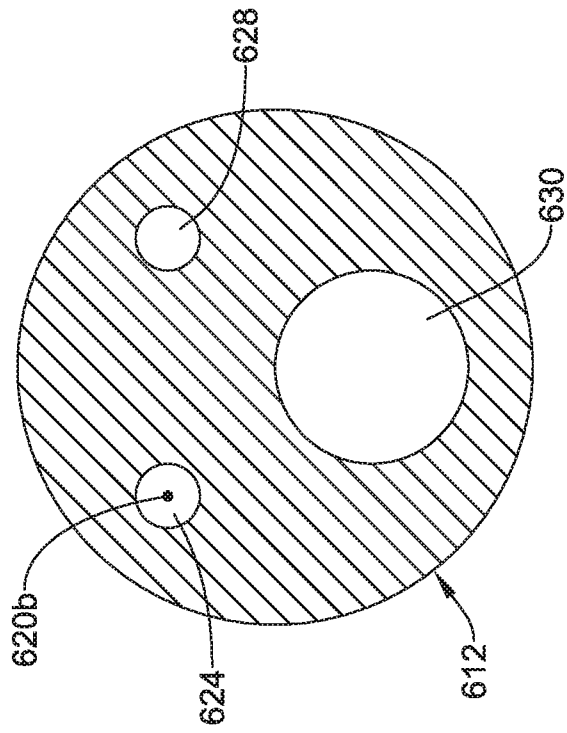

FIG. 34

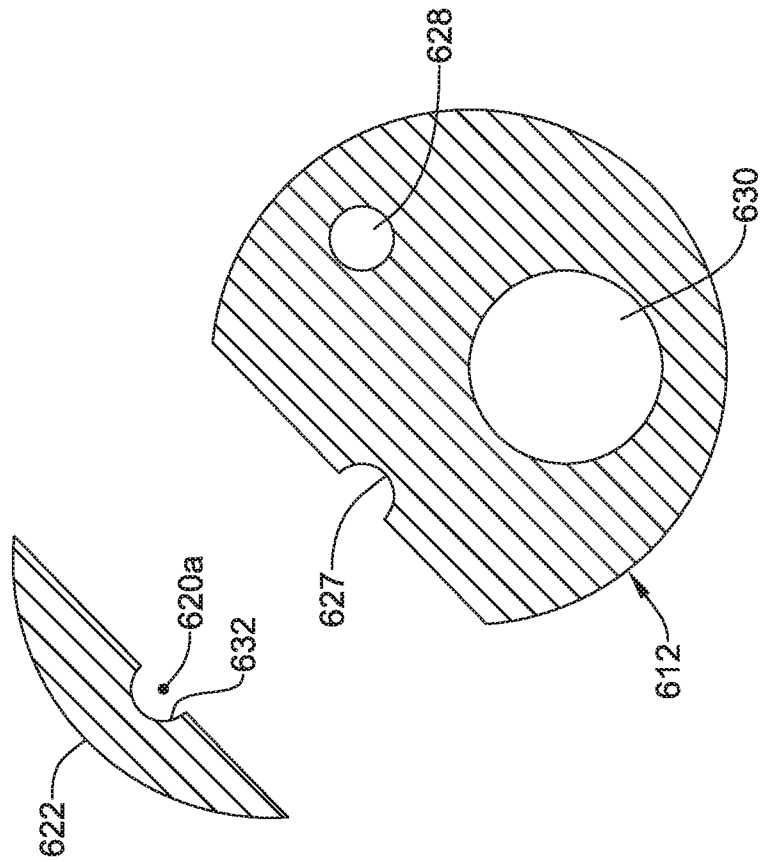

FIG. 35

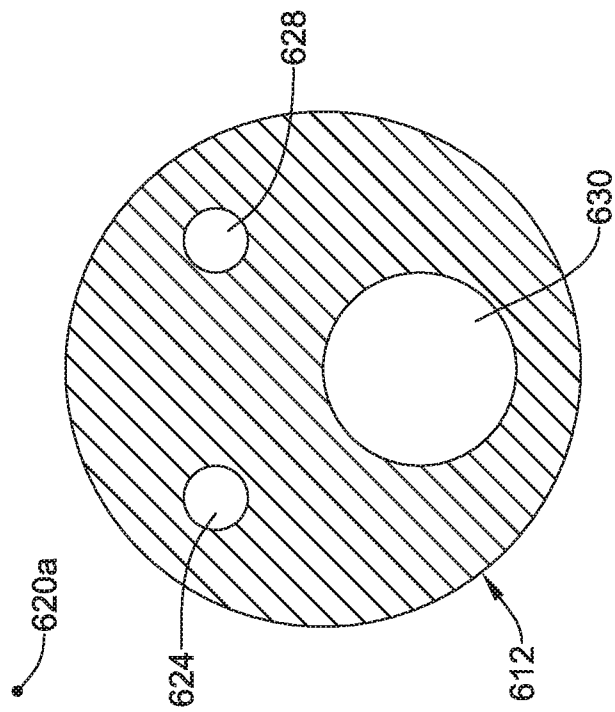

FIG. 36

37 / 57

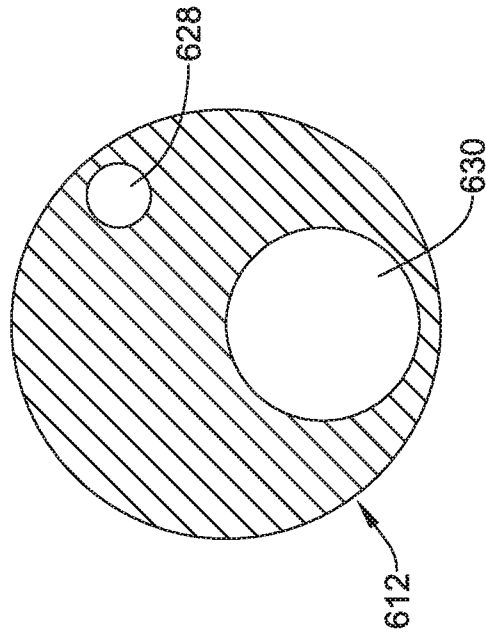

FIG. 37

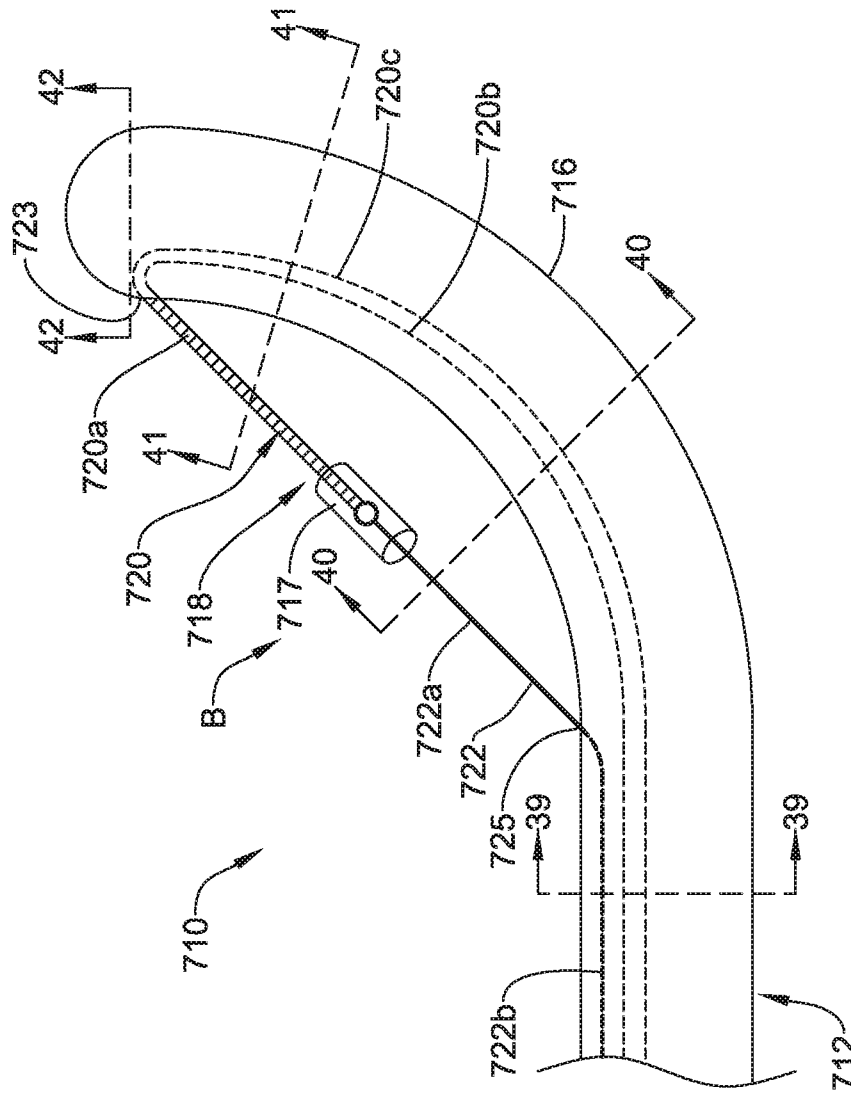

FIG. 38

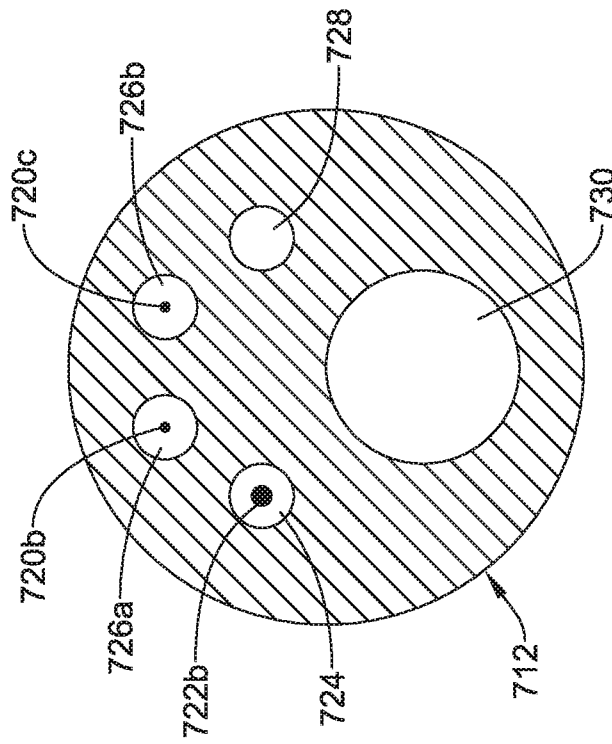

FIG. 39

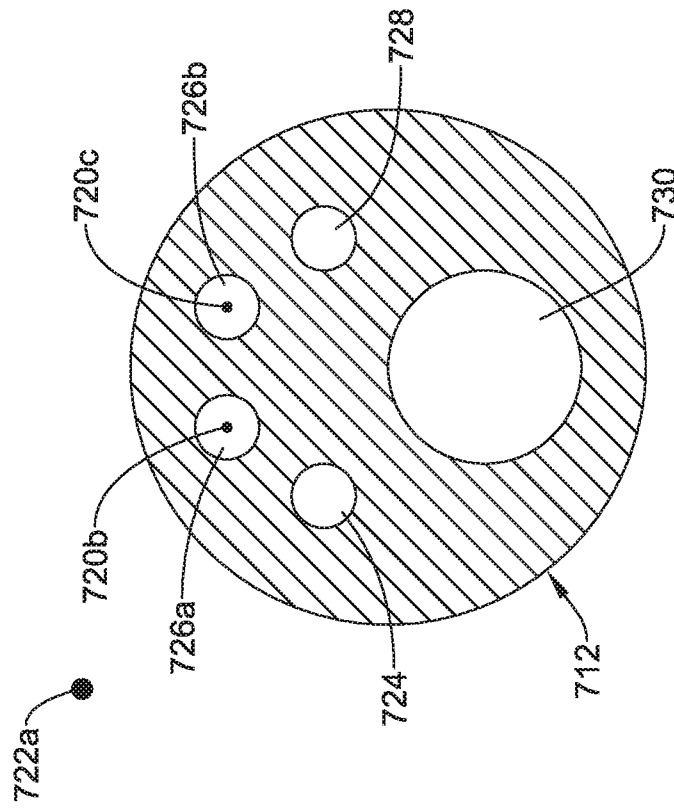

FIG. 40

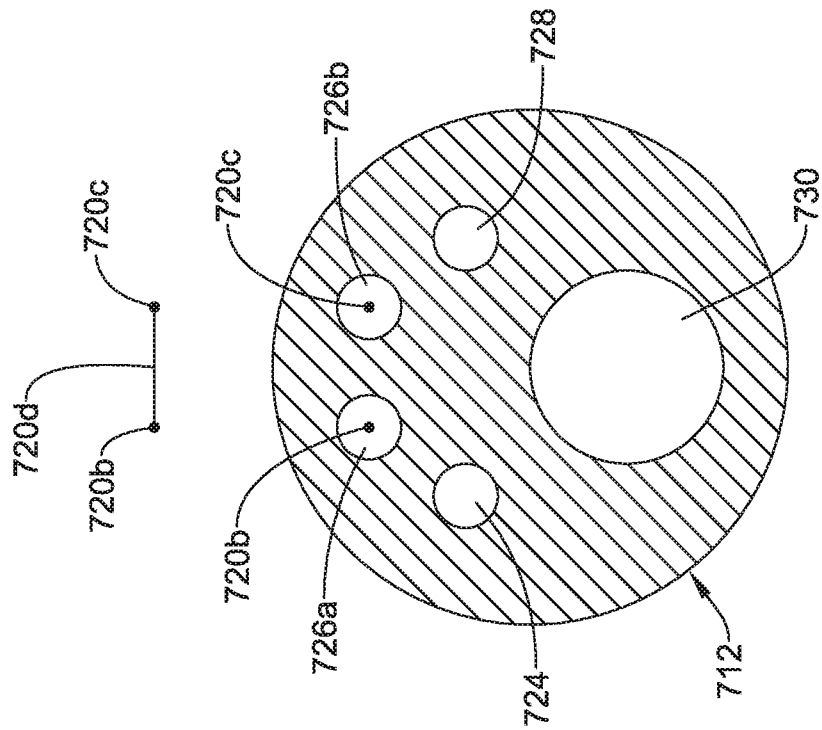

FIG. 41

42 / 57

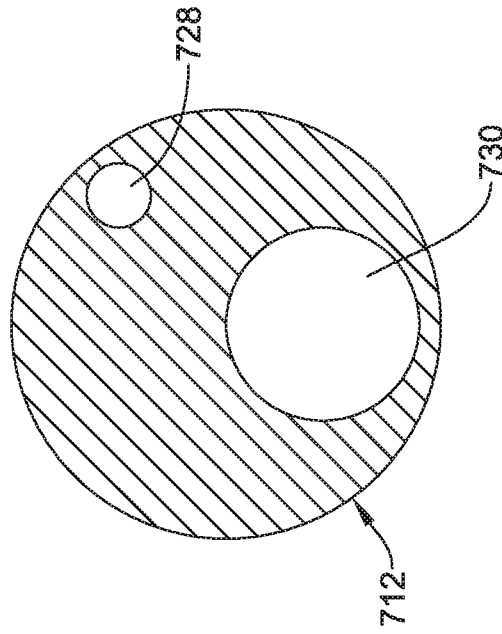

FIG. 42

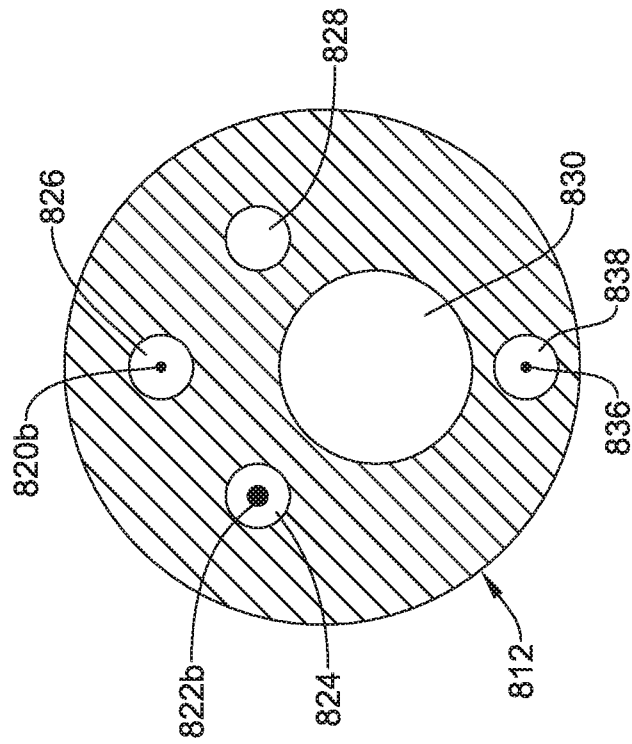

FIG. 44

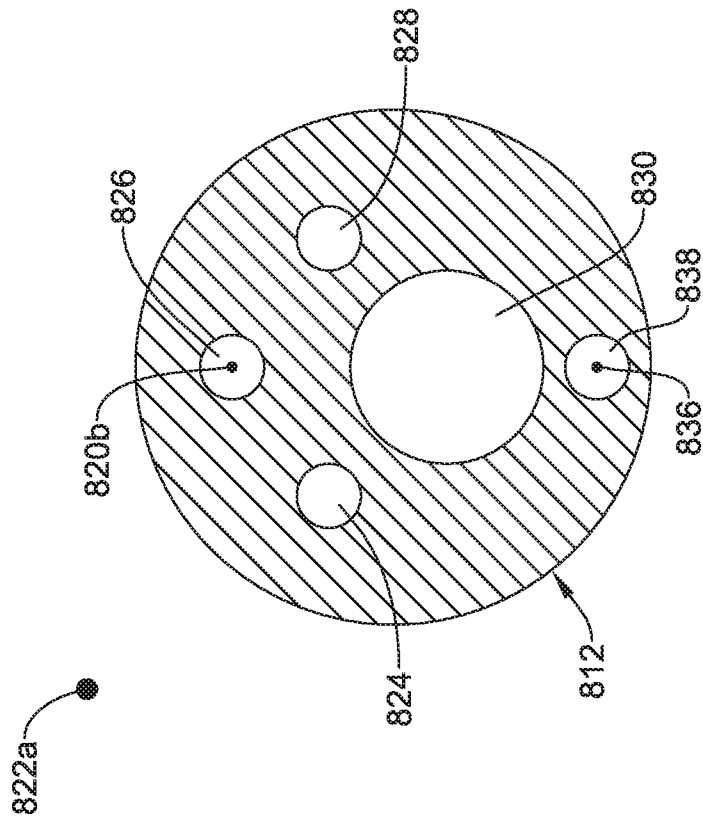

FIG. 45

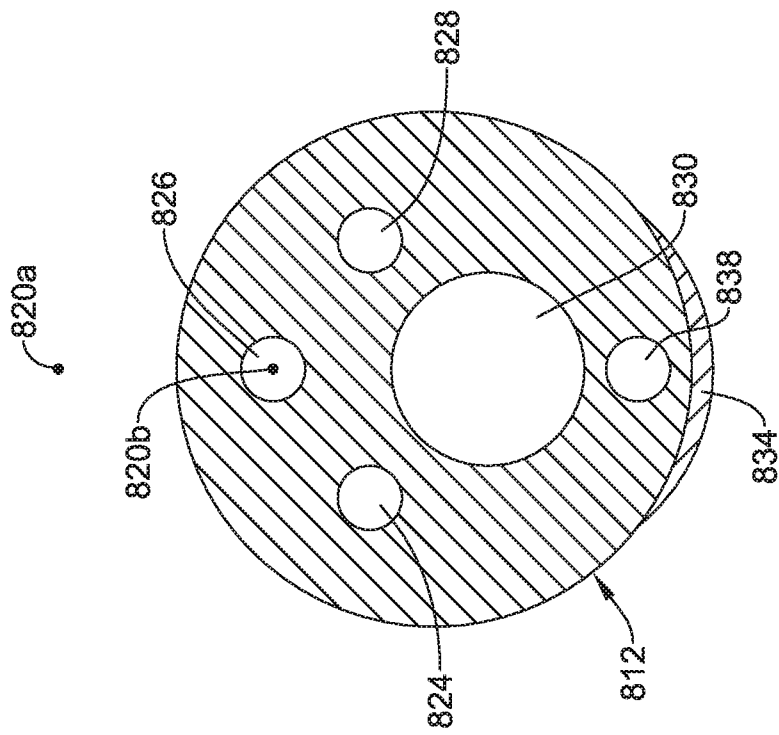

FIG. 46

47 / 57

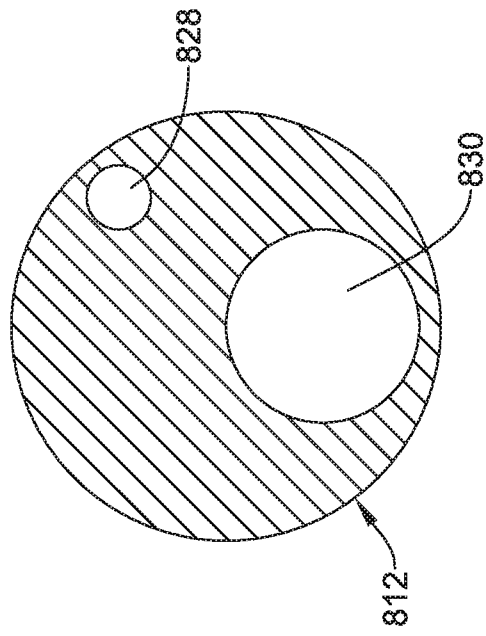

FIG. 47

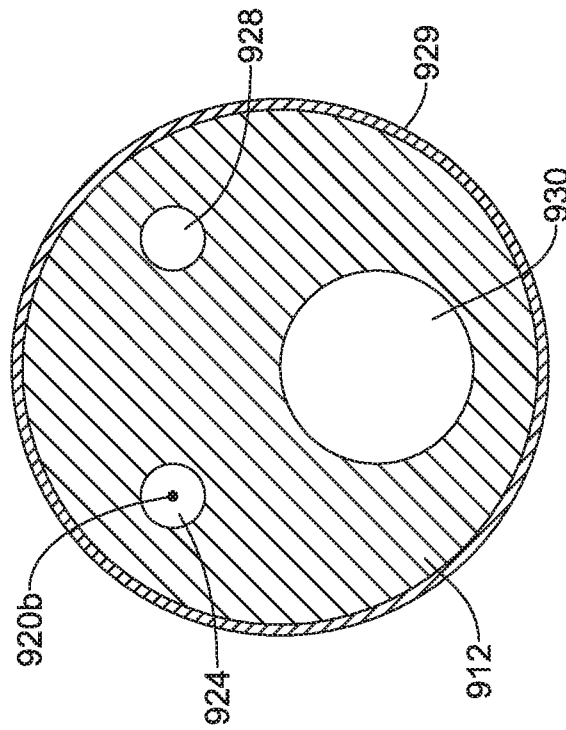

FIG. 49

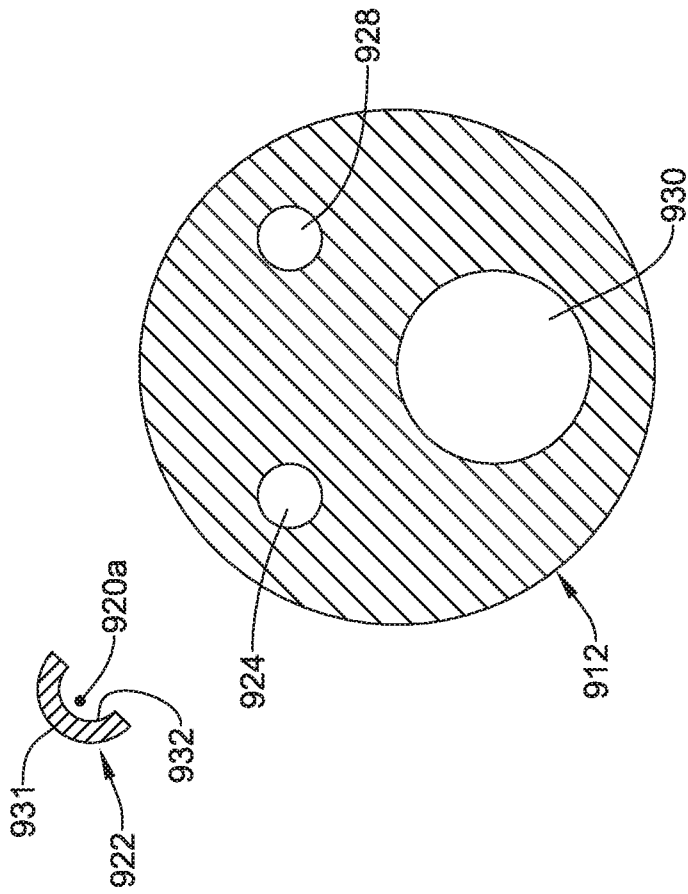

FIG. 50

51 / 57

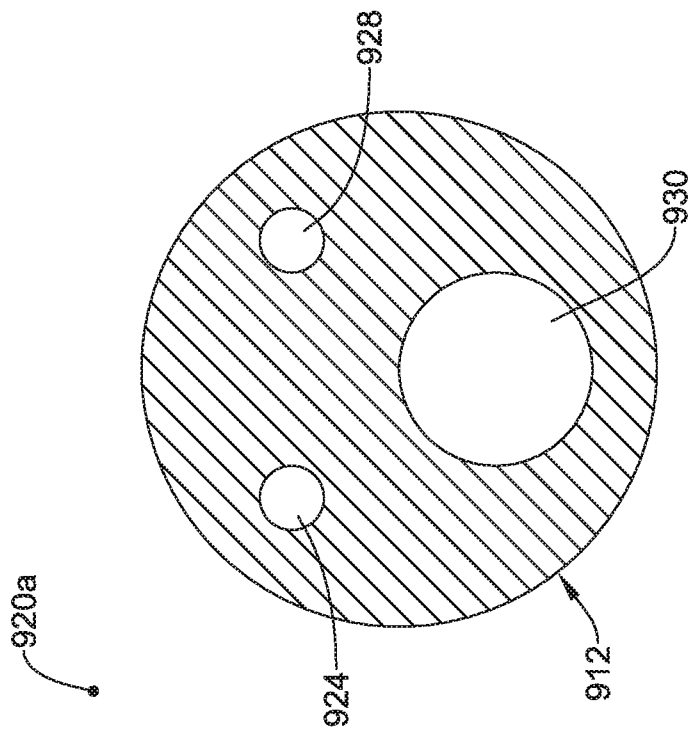

FIG. 51

52 / 57

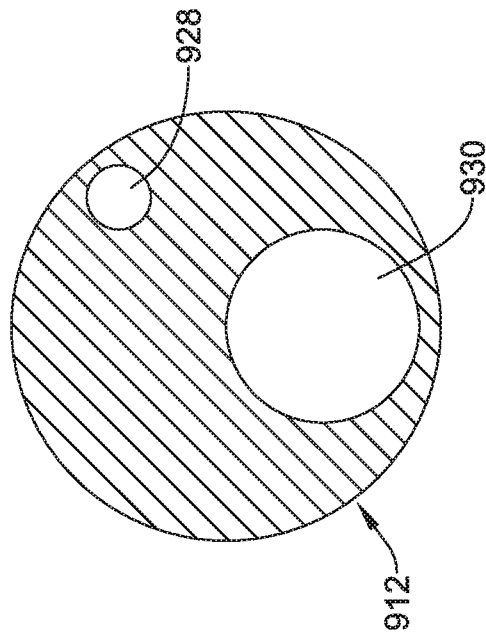

FIG. 52

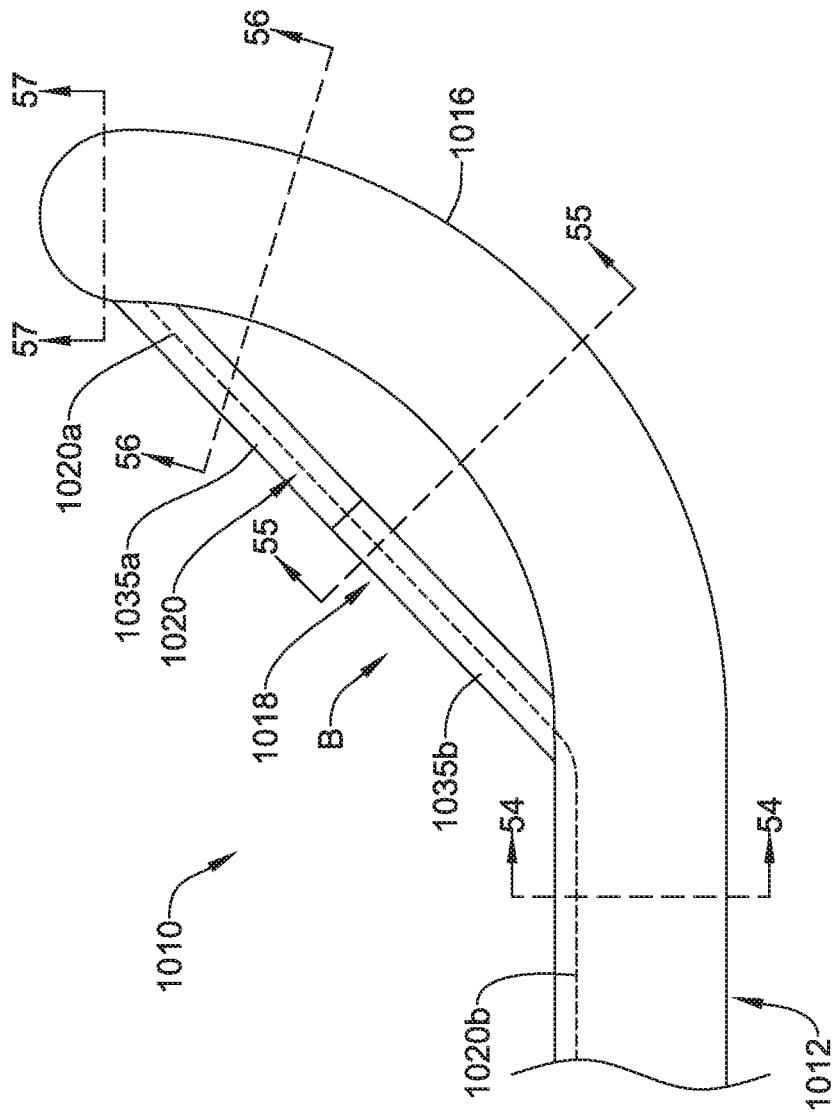

FIG. 53

54 / 57

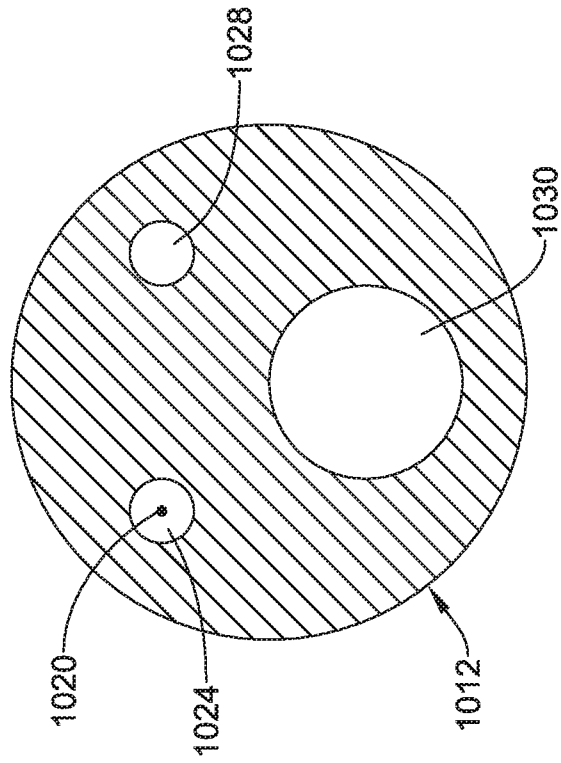

FIG. 54

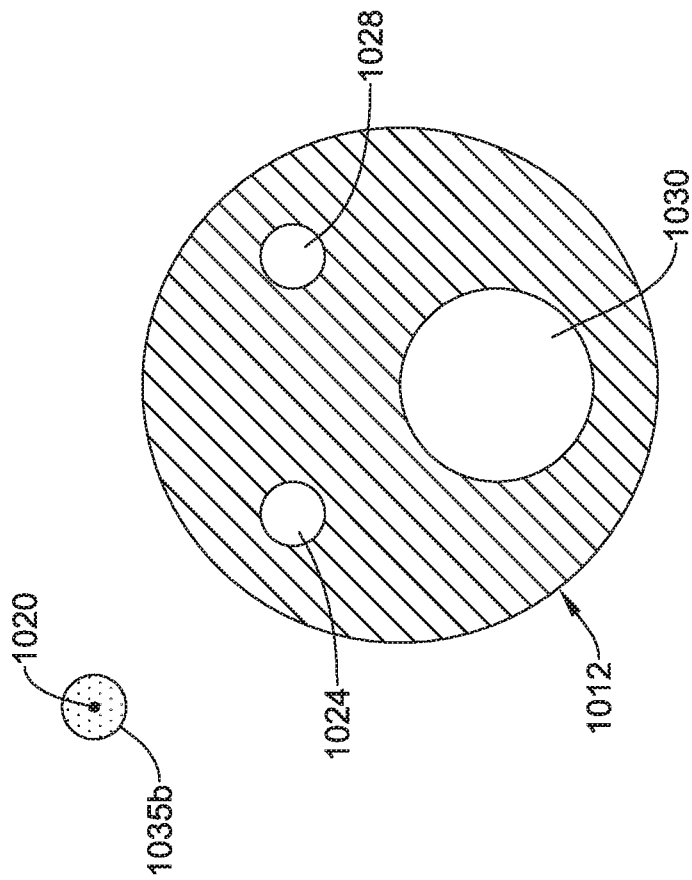

FIG. 55

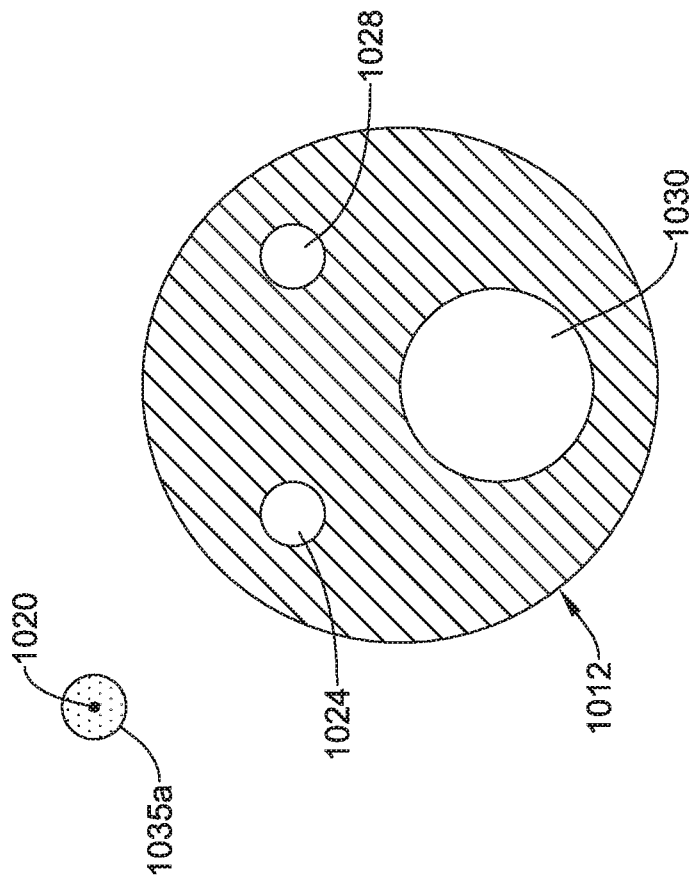

FIG. 56

57 / 57

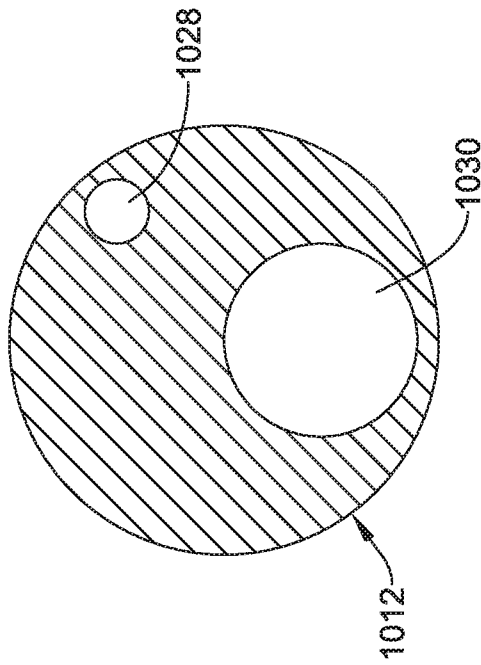

FIG. 57

