

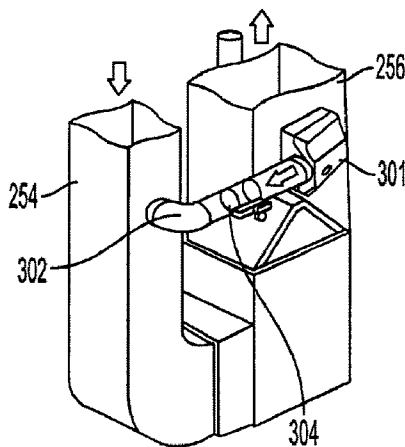

(22) Date de dépôt/Filing Date: 2019/11/27
(41) Mise à la disp. pub./Open to Public Insp.: 2020/06/04
(45) Date de délivrance/Issue Date: 2024/05/14
(30) Priorité/Priority: 2018/12/04 (US16/208,858)

(51) Cl.Int./Int.Cl. *F24F 11/70* (2018.01),
F24F 13/02 (2006.01), *F24F 3/14* (2006.01)
(72) Inventeurs/Inventors:
GOEL, RAKESH, US;
PEREZ, ERIC, US;
BERG, ERIC, US
(73) Propriétaire/Owner:
LENNOX INDUSTRIES INC., US
(74) Agent: MARKS & CLERK

(54) Titre : PROCÉDE ET SYSTÈME D'UTILISATION D'HUMIDIFICATEUR AVEC DERIVATION POUR
DESHUMIDIFICATION PENDANT LE REFROIDISSEMENT
(54) Title: METHOD AND SYSTEM FOR UTILIZING A BYPASS HUMIDIFIER FOR DEHUMIDIFICATION DURING
COOLING



(57) **Abrégé/Abstract:**

An HVAC system includes an indoor heat-exchange coil disposed between a supply air duct and a return air duct. A damper is disposed in a re-circulation duct and is moveable between an open position and a closed position. A controller is configured to determine if the HVAC system is operating in a heating mode or an air-conditioning mode. Responsive to a determination that the HVAC system is operating in the air-conditioning mode, the controller is configured to determine if the variable-speed indoor circulation fan is operating at a minimum speed and if the relative humidity measured by the humidity sensor is above a pre-determined threshold. Responsive to a determination that the variable-speed indoor circulation fan is operating at the minimum speed and the relative humidity of the enclosed space is above the pre-determined threshold, the controller signals the damper to move to the open position.

ABSTRACT

An HVAC system includes an indoor heat-exchange coil disposed between a supply air duct and a return air duct. A damper is disposed in a re-circulation duct and is moveable between an open position and a closed position. A controller is configured to determine if the HVAC system is operating in a heating mode or an air-conditioning mode. Responsive to a determination that the HVAC system is operating in the air-conditioning mode, the controller is configured to determine if the variable-speed indoor circulation fan is operating at a minimum speed and if the relative humidity measured by the humidity sensor is above a pre-determined threshold. Responsive to a determination that the variable-speed indoor circulation fan is operating at the minimum speed and the relative humidity of the enclosed space is above the pre-determined threshold, the controller signals the damper to move to the open position.

METHOD AND SYSTEM FOR UTILIZING A BYPASS HUMIDIFIER FOR DEHUMIDIFICATION DURING COOLING

CROSS-REFERENCE TO RELATED APPLICATIONS

[0001] The present application is related to United States Patent Publication US20210172642 and titled METHOD AND SYSTEM FOR SUPPLY-AIR RE-CIRCULATION, now granted as United States Patent US11788761.

TECHNICAL FIELD

[0002] The present disclosure relates generally to heating, ventilation, and air conditioning (HVAC) systems and more particularly, but not by way of limitation, to utilizing a re-circulation duct to utilize a bypass humidifier for dehumidification during cooling.

BACKGROUND

[0003] This section provides background information to facilitate a better understanding of the various aspects of the disclosure. It should be understood that the statements in this section of this document are to be read in this light, and not as admissions of prior art.

[0004] HVAC systems are used to regulate environmental conditions within an enclosed space. Typically, HVAC systems have a circulation fan that pulls air from the enclosed space through ducts and pushes the air back into the enclosed space through additional ducts after conditioning the air (*e.g.*, heating, cooling, humidifying, or dehumidifying the air). To direct operation of the circulation fan and other components, HVAC systems include a controller. In addition to directing operation of the HVAC system, the controller may be used to monitor various components, (*i.e.* equipment) of the HVAC system to determine if the components are functioning properly.

SUMMARY

[0005] Various aspects of the disclosure relate to a heating, ventilation, and air conditioning (HVAC) system. The HVAC system includes an indoor heat-exchange coil disposed between a supply air duct and a return air duct. A re-circulation duct fluidly couples the supply air duct and the return air duct. A damper is disposed in the re-circulation duct and is

moveable between an open position and a closed position. A controller operatively coupled to a variable-speed compressor, a variable-speed indoor circulation fan, and the damper. A humidity sensor is disposed in an enclosed space and is configured to measure a relative humidity in the enclosed space. The controller is configured to determine if the HVAC system is operating in a heating mode or an air-conditioning mode. Responsive to a determination that the HVAC system is operating in the heating mode, the controller signals the damper to move to the open position. Responsive to a determination that the HVAC system is operating in the air-conditioning mode, the controller is configured to determine if the variable-speed indoor circulation fan is operating at a minimum speed and if the relative humidity measured by the humidity sensor is above a pre-determined threshold. Responsive to a determination that the variable-speed indoor circulation fan is operating at the minimum speed and the relative humidity of the enclosed space is above the pre-determined threshold, the controller signals the damper to move to the open position. Responsive to a determination that the variable-speed indoor circulation fan is not operating at the minimum speed or the relative humidity of the enclosed space is below the pre-determined threshold, the controller signals the damper to move to the closed position.

[0006] Various aspects of the disclosure relate to a heating, ventilation, and air conditioning (HVAC) system. The HVAC system includes a supply air duct, a return air duct, and a re-circulation duct that fluidly couples the supply air duct and the return air duct. A damper is disposed in the re-circulation duct and is moveable between an open position and a closed position. A controller operatively coupled to the damper. A humidity sensor is disposed in an enclosed space and is configured to measure a relative humidity of the enclosed space. The controller is configured to determine if the HVAC system is operating in a heating mode or an air-conditioning mode. Responsive to a determination that the HVAC system is operating in the heating mode, the controller signals the damper to move to the open position. Responsive to a determination that the HVAC system is operating in the air-conditioning mode, the controller is configured to determine if the relative humidity measured by the humidity sensor is above a pre-determined threshold. Responsive to a determination that the relative humidity of the enclosed space is above the pre-determined threshold, the controller signals the damper to move to the open position. Responsive to a determination that the relative humidity of the enclosed space is

below the pre-determined threshold, the controller signals the damper to move to the closed position.

[0007] Various aspects of the disclosure relate to a method of operating an HVAC system. The HVAC system includes determining, using an HVAC controller, if the HVAC system is operating in a heating mode or an air-conditioning mode. Responsive to a determination that the HVAC system is operating in the heating mode, a damper arranged in a re-circulation duct that fluidly couples a supply air duct to a return air duct is closed. Responsive to a determination that the HVAC system is operating in the air-conditioning mode, damper is closed. In various embodiments, the method includes determining, using the HVAC controller, if a relative humidity of an enclosed space is above a pre-determined threshold. Responsive to a determination that the relative humidity of the enclosed space is not above the pre-determined threshold, the damper is retained in the closed position. Responsive to a determination that the relative humidity of the enclosed space is above the pre-determined threshold, determining using the HVAC controller, if an indoor circulation fan is operating at a minimum speed. Responsive to a determination that the indoor circulation fan is not operating at the minimum speed, the speed of the indoor circulation fan is reduced. Responsive to a determination that the indoor circulation fan is operating at the minimum speed, the damper is opened.

[0008] This summary is provided to introduce a selection of concepts that are further described below in the detailed description. This summary is not intended to identify key or essential features of the claimed subject matter, nor is it intended to be used as an aid in limiting the scope of claimed subject matter.

BRIEF DESCRIPTION OF THE DRAWINGS

[0009] The disclosure is best understood from the following detailed description when read with the accompanying figures. It is emphasized that, in accordance with standard practice in the industry, various features are not drawn to scale. In fact, the dimensions of various features may be arbitrarily increased or reduced for clarity of discussion.

[00010] FIGURE 1 is a block diagram of an exemplary HVAC system;

[00011] FIGURE 2 is a schematic diagram of an exemplary HVAC system having a

humidity sensor according to aspects of the disclosure;

[00012] FIGURE 3 is a perspective view of a horizontally aligned supply air duct and return air duct of the HVAC system according to aspects of the disclosure;

[00013] FIGURE 4 is a perspective view of an upflow supply air duct and return air duct according to aspects of the disclosure; and

[00014] FIGURE 5 is a flow diagram of a process for utilizing a bypass duct in cooling mode according to aspects of the disclosure.

DETAILED DESCRIPTION

[00015] Various embodiments will now be described more fully with reference to the accompanying drawings. The disclosure may, however, be embodied in many different forms and should not be construed as limited to the embodiments set forth herein.

[00016] HVAC systems are frequently utilized to adjust both temperature of conditioned air as well as relative humidity of the conditioned air. A cooling capacity of an HVAC system is a combination of the HVAC system's *sensible cooling capacity* and *latent cooling capacity*. *Sensible cooling capacity* refers to an ability of the HVAC system to remove sensible heat from conditioned air. *Latent cooling capacity* refers to an ability of the HVAC system to remove latent heat from conditioned air. In a typical embodiment, sensible cooling capacity and latent cooling capacity vary with environmental conditions. *Sensible heat* refers to heat that, when added to or removed from the conditioned air, results in a temperature change of the conditioned air. *Latent heat* refers to heat that, when added to or removed from the conditioned air, results in a phase change of, for example, water within the conditioned air. *Sensible-to-total ratio* ("*S/T ratio*") is a ratio of sensible heat to total heat (sensible heat + latent heat). The lower the S/T ratio, the higher the latent cooling capacity of the HVAC system for given environmental conditions.

[00017] *Sensible cooling load* refers to an amount of heat that must be removed from the enclosed space to accomplish a desired temperature change of the air within the enclosed space. The sensible cooling load is reflected by a temperature within the enclosed space as read on a dry-bulb thermometer. *Latent cooling load* refers to an amount of heat that must be removed from the enclosed space to accomplish a desired change in humidity of the air within the enclosed space. The latent cooling load is reflected by a temperature within the enclosed space as read on a wet-bulb thermometer. *Setpoint* or *temperature setpoint* refers to a target temperature setting of the HVAC system as set by a user or automatically based on a pre-defined schedule.

[00018] When there is a high sensible cooling load such as, for example, when outside-air temperature is significantly warmer than an inside-air temperature setpoint, the HVAC system will continue to operate in an effort to effectively cool and dehumidify the

conditioned air. When there is a low sensible cooling load but high relative humidity such as, for example, when the outside air temperature is relatively close to the inside air temperature setpoint, but the outside air is considerably more humid than the inside air, supplemental air dehumidification is often undertaken to avoid occupant discomfort.

[00019] An existing approach to air dehumidification involves lowering the temperature setpoint of the HVAC system. This approach causes the HVAC system to operate for longer periods of time than if the temperature setpoint of the HVAC system were set to a higher temperature. This approach serves to reduce both the temperature and humidity of the conditioned air. However, this approach results in over-cooling of the conditioned air, which over-cooling often results in occupant discomfort. Additionally, consequent extended run times cause the HVAC system to consume more energy, which leads to higher utility costs. Another air dehumidification approach involves re-heating of air leaving an evaporator coil.

[00020] In HVAC systems having a variable-speed compressor, the compressor speed may be modulated with the cooling load. In an effort to maintain a desirable S/T ratio, a speed of an indoor circulation fan may also be adjusted with the compressor speed. In practice, however, this can be difficult to accomplish as mechanical limitations of the indoor circulation fan establish a minimum possible CFM. Additionally, very low CFM results in poor air distribution within the enclosed space.

[00021] FIGURE 1 illustrates an HVAC system 100. In a typical embodiment, the HVAC system 100 is a networked HVAC system that is configured to condition air via, for example, heating, cooling, humidifying, or dehumidifying air within an enclosed space 101. In a typical embodiment, the enclosed space 101 is, for example, a house, an office building, a warehouse, and the like. Thus, the HVAC system 100 can be a residential system or a commercial system such as, for example, a roof top system. For exemplary illustration, the HVAC system 100 as illustrated in FIGURE 1 includes various components; however, in other embodiments, the HVAC system 100 may include additional components that are not illustrated but typically included within HVAC systems.

[00022] The HVAC system 100 includes a variable-speed indoor circulation fan 110, a gas heat 120, electric heat 122 typically associated with the variable-speed indoor circulation fan

110, and an indoor heat-exchange coil 130, also typically associated with the variable-speed indoor circulation fan 110. The variable-speed indoor circulation fan 110, the gas heat 120, the electric heat 122, and the indoor heat-exchange coil 130 are collectively referred to as an “indoor unit” 148. In a typical embodiment, the indoor unit 148 is located within, or in close proximity to, the enclosed space 101. The HVAC system 100 also includes a variable-speed compressor 140 and an associated outdoor heat-exchange coil 142, which are typically referred to as an “outdoor unit” 144. In various embodiments, the outdoor unit 144 is, for example, a rooftop unit or a ground-level unit. The variable-speed compressor 140 and the associated outdoor heat-exchange coil 142 are connected to an associated indoor heat-exchange coil 130 by a refrigerant line 146. In a typical embodiment, the variable-speed compressor 140 may be, for example, a single-stage compressor or a multi-stage compressor. The variable-speed indoor circulation fan 110, sometimes referred to as a blower, is configured to operate at different capacities (*i.e.*, variable motor speeds) to circulate air through the HVAC system 100, whereby the circulated air is conditioned and supplied to the enclosed space 101.

[00023] Still referring to FIGURE 1, the HVAC system 100 includes an HVAC controller 150 that is configured to control operation of the various components of the HVAC system 100 such as, for example, the variable-speed indoor circulation fan 110, the gas heat 120, the electric heat 122, and the variable-speed compressor 140 to regulate the environment of the enclosed space 101. In some embodiments, the HVAC system 100 can be a zoned system. In such embodiments, the HVAC system 100 includes a zone controller 180, dampers 185, and a plurality of environment sensors 160. In a typical embodiment, the HVAC controller 150 cooperates with the zone controller 180 and the dampers 185 to regulate the environment of the enclosed space 101.

[00024] The HVAC controller 150 may be an integrated controller or a distributed controller that directs operation of the HVAC system 100. In a typical embodiment, the HVAC controller 150 includes an interface to receive, for example, thermostat calls, temperature setpoints, blower control signals, environmental conditions, and operating mode status for various zones of the HVAC system 100. For example, in a typical embodiment, the environmental conditions may include indoor temperature and relative humidity of the enclosed space 101. In a typical embodiment, the HVAC controller 150 also includes a processor and a

memory to direct operation of the HVAC system 100 including, for example, a speed of the variable-speed indoor circulation fan 110.

[00025] Still referring to FIGURE 1, in some embodiments, the plurality of environment sensors 160 are associated with the HVAC controller 150 and also optionally associated with a user interface 170. The plurality of environment sensors 160 provide environmental information within a zone or zones of the enclosed space 101 such as, for example, temperature and humidity of the enclosed space 101 to the HVAC controller 150. The plurality of environment sensors 160 may also send the environmental information to a display of the user interface 170. In some embodiments, the user interface 170 provides additional functions such as, for example, operational, diagnostic, status message display, and a visual interface that allows at least one of an installer, a user, a support entity, and a service provider to perform actions with respect to the HVAC system 100. In some embodiments, the user interface 170 is, for example, a thermostat of the HVAC system 100. In other embodiments, the user interface 170 is associated with at least one sensor of the plurality of environment sensors 160 to determine the environmental condition information and communicate that information to the user. The user interface 170 may also include a display, buttons, a microphone, a speaker, or other components to communicate with the user. Additionally, the user interface 170 may include a processor and memory that is configured to receive user-determined parameters such as, for example, a relative humidity of the enclosed space 101, and calculate operational parameters of the HVAC system 100 as disclosed herein.

[00026] In a typical embodiment, the HVAC system 100 is configured to communicate with a plurality of devices such as, for example, a monitoring device 156, a communication device 155, and the like. In a typical embodiment, the monitoring device 156 is not part of the HVAC system. For example, the monitoring device 156 is a server or computer of a third party such as, for example, a manufacturer, a support entity, a service provider, and the like. In other embodiments, the monitoring device 156 is located at an office of, for example, the manufacturer, the support entity, the service provider, and the like.

[00027] In a typical embodiment, the communication device 155 is a non-HVAC device having a primary function that is not associated with HVAC systems. For example, non-

HVAC devices include mobile-computing devices that are configured to interact with the HVAC system 100 to monitor and modify at least some of the operating parameters of the HVAC system 100. Mobile computing devices may be, for example, a personal computer (e.g., desktop or laptop), a tablet computer, a mobile device (e.g., smart phone), and the like. In a typical embodiment, the communication device 155 includes at least one processor, memory and a user interface, such as a display. One skilled in the art will also understand that the communication device 155 disclosed herein includes other components that are typically included in such devices including, for example, a power supply, a communications interface, and the like.

[00028] The zone controller 180 is configured to manage movement of conditioned air to designated zones of the enclosed space 101. Each of the designated zones include at least one conditioning or demand unit such as, for example, the gas heat 120 and at least one user interface 170 such as, for example, the thermostat. The zone-controlled HVAC system 100 allows the user to independently control the temperature in the designated zones. In a typical embodiment, the zone controller 180 operates electronic dampers 185 to control air flow to the zones of the enclosed space 101.

[00029] In some embodiments, a data bus 190, which in the illustrated embodiment is a serial bus, couples various components of the HVAC system 100 together such that data is communicated therebetween. In a typical embodiment, the data bus 190 may include, for example, any combination of hardware, software embedded in a computer readable medium, or encoded logic incorporated in hardware or otherwise stored (e.g., firmware) to couple components of the HVAC system 100 to each other. As an example and not by way of limitation, the data bus 190 may include an Accelerated Graphics Port (AGP) or other graphics bus, a Controller Area Network (CAN) bus, a front-side bus (FSB), a HYPERTRANSPORT (HT) interconnect, an INFINIBAND interconnect, a low-pin-count (LPC) bus, a memory bus, a Micro Channel Architecture (MCA) bus, a Peripheral Component Interconnect (PCI) bus, a PCI-Express (PCI-X) bus, a serial advanced technology attachment (SATA) bus, a Video Electronics Standards Association local (VLB) bus, or any other suitable bus or a combination of two or more of these. In various embodiments, the data bus 190 may include any number, type, or configuration of data buses 190, where appropriate. In particular embodiments, one or more data buses 190 (which may each include an address bus and a data bus) may couple the HVAC

controller 150 to other components of the HVAC system 100. In other embodiments, connections between various components of the HVAC system 100 are wired. For example, conventional cable and contacts may be used to couple the HVAC controller 150 to the various components. In some embodiments, a wireless connection is employed to provide at least some of the connections between components of the HVAC system such as, for example, a connection between the HVAC controller 150 and the variable-speed indoor circulation fan 110 or the plurality of environment sensors 160.

[00030] FIGURE 2 is a schematic diagram of the exemplary HVAC system 100 with a humidity sensor 220. For illustrative purposes, FIGURE 2 will be described herein relative to FIGURE 1. In various embodiments, the HVAC system 100 may operate in a heating mode or an air-conditioning mode. When the HVAC system 100 is operating in the air-conditioning mode, the HVAC system 100 may further operate in one of a cooling mode or a dehumidification mode. The HVAC system 100 includes the indoor heat-exchange coil 130, the outdoor heat-exchange coil 142, the variable-speed compressor 140, and a metering device 202. In a typical embodiment, the metering device 202 is, for example, a thermostatic expansion valve or a throttling valve. The indoor heat-exchange coil 130 is fluidly coupled to the variable-speed compressor 140 via a suction line 204. The variable-speed compressor 140 is fluidly coupled to the outdoor heat-exchange coil 142 via a discharge line 206. The outdoor heat-exchange coil 142 is fluidly coupled to the metering device 202 via a liquid line 208.

[00031] Still referring to FIGURE 2, during operation, low-pressure, low-temperature refrigerant is circulated through the indoor heat-exchange coil 130. The refrigerant is initially in a liquid/vapor state. In a typical embodiment, the refrigerant is, for example, R-22, R-134a, R-410A, R-744, or any other suitable type of refrigerant as dictated by design requirements. Air from within the enclosed space 101, which is typically warmer than the refrigerant, is circulated around the indoor heat-exchange coil 130 by the variable-speed indoor circulation fan 110. When the HVAC system operates in the air-conditioning mode, the indoor heat-exchange coil 130 functions as an evaporator. Thus, the refrigerant begins to boil after absorbing heat from the air and changes state to a low-pressure, low-temperature, super-heated vapor refrigerant. *Saturated vapor, saturated liquid, and saturated fluid* refer to a thermodynamic state where a liquid and its vapor exist in approximate equilibrium with each other. *Super-heated fluid* and

super-heated vapor refer to a thermodynamic state where a vapor is heated above a saturation temperature of the vapor. *Sub-cooled fluid* and *sub-cooled liquid* refers to a thermodynamic state where a liquid is cooled below the saturation temperature of the liquid.

[00032] The low-pressure, low-temperature, super-heated vapor refrigerant is introduced into the variable-speed compressor 140 via the suction line 204. In a typical embodiment, the variable-speed compressor 140 increases the pressure of the low-pressure, low-temperature, super-heated vapor refrigerant and, by operation of the ideal gas law, also increases the temperature of the low-pressure, low-temperature, super-heated vapor refrigerant to form a high-pressure, high-temperature, superheated vapor refrigerant. The high-pressure, high-temperature, superheated vapor refrigerant leaves the variable-speed compressor 140 via the discharge line 206 and is directed to the outdoor heat-exchange coil 142.

[00033] Outside air is circulated around the outdoor heat-exchange coil 142 by an outdoor fan 210. The outside air is typically cooler than the high-pressure, high-temperature, superheated vapor refrigerant present in the outdoor heat-exchange coil 142. When the HVAC system 100 is operating in the air-conditioning mode, the outdoor heat-exchange coil 142 functions as a condenser. Thus, in the air-conditioning mode, heat is transferred from the high-pressure, high-temperature, superheated vapor refrigerant to the outside air. Removal of heat from the high-pressure, high-temperature, superheated vapor refrigerant causes the high-pressure, high-temperature, superheated vapor refrigerant to condense and change from a vapor state to a high-pressure, high-temperature, sub-cooled liquid state. The high-pressure, high-temperature, sub-cooled liquid refrigerant leaves the outdoor heat-exchange coil 142 via the liquid line 208 and enters the metering device 202.

[00034] Still referring to FIGURE 2, when the HVAC system is operating in the heating mode, the direction of refrigerant flow is reversed. Thus, in the heating mode, the indoor heat-exchange coil 130 functions as a condenser and the outdoor heat-exchange coil 142 functions as an evaporator. In various embodiments, reversal of refrigerant flow is accomplished by a reversing valve 207.

[00035] In the metering device 202, the pressure of the high-pressure, high-temperature, sub-cooled liquid refrigerant is abruptly reduced. In various embodiments where

the metering device 202 is, for example, a thermostatic expansion valve, the metering device 202 reduces the pressure of the high-pressure, high-temperature, sub-cooled liquid refrigerant by regulating an amount of refrigerant that travels to the indoor heat-exchange coil 130. Abrupt reduction of the pressure of the high-pressure, high-temperature, sub-cooled liquid refrigerant causes sudden, rapid, evaporation of a portion of the high-pressure, high-temperature, sub-cooled liquid refrigerant, commonly known as “flash evaporation.” The flash evaporation lowers the temperature of the resulting liquid/vapor refrigerant mixture to a temperature lower than a temperature of the air in the enclosed space 101. The liquid/vapor refrigerant mixture leaves the metering device 202 and returns to the indoor heat-exchange coil 130.

[00036] Still referring to FIGURE 2, the HVAC controller 150 is operatively coupled to the variable-speed indoor circulation fan 110 and the variable-speed compressor 140. A humidity sensor 220 is disposed in the enclosed space 101 and is adapted to measure a relative humidity of the air within the enclosed space 101. In various embodiments, the humidity sensor 220 may be integral with the HVAC controller 150. That is, the HVAC controller itself may be disposed in the enclosed space 101. In other embodiments, the humidity sensor 220 may be located remotely from the HVAC controller 150 and may communicate with the HVAC controller via a wired connection or a wireless protocol. When the HVAC system 100 is operating in the cooling mode, a speed of the variable-speed compressor 140 may be adjusted to correspond to changing cooling loads. The HVAC controller 150 adjusts a speed of the variable-speed indoor circulation fan 110 relative to a speed of the variable-speed compressor 140. Thus, by way of example, a decrease in the speed of the variable-speed compressor 140 is detected by the HVAC controller 150. The HVAC controller 150 then signals the variable-speed indoor circulation fan 110 to reduce speed. In certain conditions, however, reduction of the speed of the variable-speed indoor circulation fan 110 is constrained by mechanical limitations of the variable-speed indoor circulation fan 110. Additionally, low speeds of the variable-speed indoor circulation fan 110 can result in ineffective air distribution throughout the enclosed space 101.

[00037] FIGURE 3 is a perspective view of a horizontally aligned supply air duct 256 and return air duct 254. FIGURE 4 is a perspective view of an upflow supply air duct 256 and return air duct 254. For illustrative purposes, FIGURES 3-4 will be described herein relative to FIGURES 1-2. A bypass humidifier 301 is fluidly coupled to the supply air duct 256. A bypass

duct 302 fluidly couples the bypass humidifier 301 to the return air duct 254. Thus, the bypass humidifier 301 and the bypass duct 302 fluidly couple the supply air duct 256 to the return air duct 254. A damper 304 is disposed in the bypass duct 302. During operation, the damper 304 is movable between an open position, which allows air to pass from the supply air duct 256, through the bypass humidifier 301, through the bypass duct 302, and into the return air duct 254, and a closed position, which does not allow passage of air through the bypass humidifier 301 or the bypass duct 302. In various embodiments, the damper 304 is electrically coupled to the HVAC controller 150 and moves between the open position and the closed position responsive to a signal from the HVAC controller 150.

[00038] Still referring to FIGURES 3-4, during operation of the HVAC system 100 in the heating mode, the HVAC controller 150 signals the damper 304 to move to the open position. Moving the damper 304 to the open position allows air to pass from the supply air duct 256, through the bypass humidifier 301, through the bypass duct 302, and into the return air duct 254. In various embodiments, the bypass humidifier 301 includes a wet, evaporative pad. In various embodiments, a motor-driven fan could be utilized to boost airflow through the bypass duct 302. As air passes through the bypass humidifier 301, moisture is absorbed into the air from the bypass humidifier 301. Thus, the bypass humidifier 301 increases the relative humidity of the air passing through the HVAC system 100 during operation of the HVAC system 100 in the heating mode.

[00039] Still referring to FIGURES 3-4, during operation of the HVAC system 100 in the air-conditioning mode, and particularly, in the cooling mode, the damper 304 is normally moved to the closed position in an effort to prevent movement or air from the supply air duct 256 and through the bypass humidifier 301. The humidity sensor 220 monitors a relative humidity of air in the enclosed space 101 and transmits a signal corresponding to the relative humidity of the enclosed space 101 to the HVAC controller 150. If the humidity sensor 220 detects a relative humidity in the enclosed space 101 above a pre-determined threshold, the HVAC controller 150 transmits a signal to the variable-speed indoor circulation fan 110 directing the variable-speed indoor circulation fan 110 to reduce speed in an effort to increase latent capacity of the HVAC system 100. If the variable-speed indoor circulation fan 110 is operating at a minimum rated speed, the HVAC controller 150 transmits a signal to the damper 304 directing the damper 304

to move from the closed position to the open position thereby allowing air to flow from the supply air duct 256 to the return air duct 254 via the bypass duct 302. In various embodiments, the pre-determined humidity threshold could be, for example, in a range of approximately 40% to approximately 60%; however, in other embodiments, other humidity thresholds could be utilized. In various embodiments, the minimum rated speed of the variable-speed indoor circulation fan 110 is a manufacturer-established minimum speed based, at least in part, on stability of the variable-speed indoor circulation fan 110 and power consumption of the variable-speed indoor circulation fan 110. In various embodiments, the minimum rated speed of the variable-speed indoor circulation fan 110 prevents operation of the variable-speed indoor circulation fan 110 in a speed range that could compromise reliability.

[00040] Still referring to FIGURES 3-4, when the damper 304 is in the open position, a portion of air discharged from the variable-speed indoor circulation fan 110 travels through the bypass duct 302 to the return air duct 254 and is not discharged to the enclosed space 101 via the supply air duct 256. Moving the damper 304 to the open position reduces a volume of air supplied to the enclosed space 101 and thus has an effect similar to that of reducing a speed of the variable-speed indoor circulation fan 110. Thus, the latent capacity of the HVAC system 100 is increased and the HVAC system 100 has better capability to remove moisture from the air. When operating in the air-conditioning mode, a water supply to the bypass humidifier 301 is turned off in an effort to prevent additional moisture being added to air passing through the bypass duct 302. In various embodiments, the evaporative pad may be removed from the bypass humidifier 301.

[00041] FIGURE 5 is a flow diagram of a process 500 for utilizing the bypass duct 302. At step 504, it is determined if the HVAC system 100 is operating in air-conditioning mode or heating mode. If at step 504, it is determined that the HVAC system is operating in the heating mode, the process 500 proceeds to step 506. At step 506, the HVAC controller 150 signals the damper 304 to move to the open position. Movement of the damper 304 to the open position allows air to move from the supply air duct 256, through the bypass humidifier 301, through the bypass duct 302, and into the return air duct 254, thereby increasing a relative humidity of the air moving through the HVAC system 100 during operation of the HVAC system 100 in the heating mode. From step 506, the process 500 returns to step 504. If at step

504, it is determined that the HVAC system 100 is operating in the air-conditioning mode, the process 500 proceeds to step 508. At step 508, the HVAC controller 150 signals the damper 304 to move to the closed position thereby preventing air from moving through the bypass humidifier 301 and the bypass duct 302. From step 508, the process 500 proceeds to step 510.

[00042] Still referring to FIGURE 5, at step 510, the humidity sensor 220 monitors a relative humidity of the enclosed space 101 and determines if the relative humidity of the enclosed space 101 is above the pre-determined threshold. If at step 510, it is determined that the relative humidity of the enclosed space 101 is not above the pre-determined threshold, the HVAC controller 150 signals the damper 304 to remain in the closed position. If at step 510, it is determined that the relative humidity of the enclosed space 101 exceeds the predetermined threshold, the process 500 proceeds to step 512. At step 512, it is determined if a speed of the variable-speed indoor circulation fan 110 can be reduced. If at step 512, it is determined that the speed of the variable-speed indoor circulation fan 110 can be reduced, the process 500 proceeds to step 514 where the speed of the variable-speed indoor circulation fan 110 is reduced. From step 514, the process 500 returns to step 510. If at step 512, it is determined that the speed of the variable-speed indoor circulation fan 110 cannot be reduced, the process 500 returns to step 506 where the HVAC controller 150 signals the damper 304 to move to the open position. Moving the damper 304 to the open position allows air to pass from the supply air duct 256, through the bypass humidifier 301, through the bypass duct 302, and into the return air duct 254. Moving the damper 304 to the open position reduces a volume of air supplied to the enclosed space 101 and thus has an effect similar to that of reducing a speed of the variable-speed indoor circulation fan 110 such that the latent capacity of the of the HVAC system 100 is increased. From step 516, the process 500 returns to step 504.

[00043] The term "substantially" is defined as largely but not necessarily wholly what is specified (and includes what is specified; e.g., substantially 90 degrees includes 90 degrees and substantially parallel includes parallel), as understood by a person of ordinary skill in the art. In any disclosed embodiment, the terms "substantially," "approximately," "generally," and "about" may be substituted with "within 10% of" what is specified.

[00044] For purposes of this patent application, the term computer-readable storage

medium encompasses one or more tangible computer-readable storage media possessing structures. As an example and not by way of limitation, a computer-readable storage medium may include a semiconductor-based or other integrated circuit (IC) (such as, for example, a field-programmable gate array (FPGA) or an application-specific IC (ASIC)), a hard disk, an HDD, a hybrid hard drive (HHD), an optical disc, an optical disc drive (ODD), a magneto-optical disc, a magneto-optical drive, a floppy disk, a floppy disk drive (FDD), magnetic tape, a holographic storage medium, a solid-state drive (SSD), a RAM-drive, a SECURE DIGITAL card, a SECURE DIGITAL drive, a flash memory card, a flash memory drive, or any other suitable tangible computer-readable storage medium or a combination of two or more of these, where appropriate.

[00045] Particular embodiments may include one or more computer-readable storage media implementing any suitable storage. In particular embodiments, a computer-readable storage medium implements one or more portions of the HVAC controller 150, one or more portions of the user interface 170, one or more portions of the zone controller 180, or a combination of these, where appropriate. In particular embodiments, a computer-readable storage medium implements RAM or ROM. In particular embodiments, a computer-readable storage medium implements volatile or persistent memory. In particular embodiments, one or more computer-readable storage media embody encoded software.

[00046] In this patent application, reference to encoded software may encompass one or more applications, bytecode, one or more computer programs, one or more executables, one or more instructions, logic, machine code, one or more scripts, or source code, and vice versa, where appropriate, that have been stored or encoded in a computer-readable storage medium. In particular embodiments, encoded software includes one or more application programming interfaces (APIs) stored or encoded in a computer-readable storage medium. Particular embodiments may use any suitable encoded software written or otherwise expressed in any suitable programming language or combination of programming languages stored or encoded in any suitable type or number of computer-readable storage media. In particular embodiments, encoded software may be expressed as source code or object code. In particular embodiments, encoded software is expressed in a higher-level programming language, such as, for example, C, Python, Java, or a suitable extension thereof. In particular embodiments, encoded software is expressed in a lower-level programming language, such as assembly language (or machine

code). In particular embodiments, encoded software is expressed in JAVA. In particular embodiments, encoded software is expressed in Hyper Text Markup Language (HTML), Extensible Markup Language (XML), or other suitable markup language.

[00047] Depending on the embodiment, certain acts, events, or functions of any of the algorithms described herein can be performed in a different sequence, can be added, merged, or left out altogether (*e.g.*, not all described acts or events are necessary for the practice of the algorithms). Moreover, in certain embodiments, acts or events can be performed concurrently, *e.g.*, through multi-threaded processing, interrupt processing, or multiple processors or processor cores or on other parallel architectures, rather than sequentially. Although certain computer-implemented tasks are described as being performed by a particular entity, other embodiments are possible in which these tasks are performed by a different entity.

[00048] Conditional language used herein, such as, among others, "can," "might," "may," "e.g.," and the like, unless specifically stated otherwise, or otherwise understood within the context as used, is generally intended to convey that certain embodiments include, while other embodiments do not include, certain features, elements and/or states. Thus, such conditional language is not generally intended to imply that features, elements and/or states are in any way required for one or more embodiments or that one or more embodiments necessarily include logic for deciding, with or without author input or prompting, whether these features, elements and/or states are included or are to be performed in any particular embodiment.

[00049] While the above detailed description has shown, described, and pointed out novel features as applied to various embodiments, it will be understood that various omissions, substitutions, and changes in the form and details of the devices or algorithms illustrated can be made without departing from the spirit of the disclosure. As will be recognized, the processes described herein can be embodied within a form that does not provide all of the features and benefits set forth herein, as some features can be used or practiced separately from others. The scope of protection is defined by the appended claims rather than by the foregoing description. All changes which come within the meaning and range of equivalency of the claims are to be embraced within their scope.

What is claimed is:

1. A heating, ventilation, and air conditioning (HVAC) system comprising:
 - an indoor heat-exchange coil disposed between a supply air duct and a return air duct;
 - a bypass duct that fluidly couples the supply air duct and the return air duct;
 - a damper disposed in the bypass duct, the damper being moveable between an open position and a closed position;
 - a variable-speed indoor circulation fan for circulating air around the indoor heat-exchange coil;
 - a variable-speed compressor fluidly coupled to the indoor heat-exchange coil;
 - a controller operatively coupled to the variable-speed compressor, the variable-speed indoor circulation fan, and the damper;
 - a humidity sensor disposed in an enclosed space, the humidity sensor being configured to measure a relative humidity in the enclosed space;
 - wherein the controller is configured to:
 - determine if the HVAC system is operating in a heating mode or an air-conditioning mode;
 - responsive to a determination that the HVAC system is operating in the heating mode, signal the damper to move to the open position;
 - responsive to a determination that the HVAC system is operating in the air-conditioning mode, signal the damper to move to the closed position;
 - determine if the relative humidity measured by the humidity sensor is above a pre-determined threshold;
 - responsive to a determination that the relative humidity of the enclosed space is not above the pre-determined threshold, retain the damper in the closed position;
 - responsive to a determination that the relative humidity of the enclosed space is above the pre-determined threshold, determine if a speed of the variable-speed indoor circulation fan can be reduced;
 - responsive to a determination that the speed of variable-speed indoor circulation fan can be reduced, reduce the speed of the variable-speed indoor circulation fan in an effort to increase latent capacity of the HVAC system; and

responsive to a determination that the speed of the variable-speed indoor circulation fan cannot be reduced, signal the damper to move to the open position to reduce a volume of air supplied to the enclosed space to create an effect similar to that of reducing the speed of the variable-speed indoor circulation fan.

2. The HVAC system of claim 1, wherein, when the HVAC system operates in the air-conditioning mode, the speed of the variable-speed indoor circulation fan is modulated responsive to a speed of the variable-speed compressor.

3. The HVAC system of claim 1, wherein, when moving the damper to the open position, a portion of the air discharged from the variable-speed indoor circulation fan travels through the bypass duct to the return air duct and is not discharged to the enclosed space via the supply air duct.

4. The HVAC system of claim 1, wherein, when the HVAC system operates in the air-conditioning mode, the HVAC system further operates in one of a cooling mode and a dehumidification mode.

5. The HVAC system of claim 1, comprising a bypass humidifier fluidly coupled to the supply air duct and the bypass duct.

6. The HVAC system of claim 5, wherein the bypass humidifier comprises a wet, evaporative pad.

7. The HVAC system of claim 1, wherein, when moving the damper to the open position, a portion of the air discharged from the variable-speed indoor circulation fan travels through the bypass duct to the return air duct and is not discharged to the enclosed space thereby increasing a latent capacity of the HVAC system.

8. A heating, ventilation, and air conditioning (HVAC) system comprising:
a supply air duct;
a return air duct;
a bypass duct that fluidly couples the supply air duct and the return air duct;
a damper disposed in the bypass duct, the damper being moveable between an open position and a closed position;
a controller operatively coupled to the damper;
a humidity sensor disposed in an enclosed space, the humidity sensor being configured to measure a relative humidity of the enclosed space;

wherein the controller is configured to:

- determine if the HVAC system is operating in a heating mode or an air-conditioning mode;
- responsive to a determination that the HVAC system is operating in the heating mode, signal the damper to move to the open position;
- responsive to a determination that the HVAC system is operating in the air-conditioning mode, signal the damper to move to the closed position;
- determine if the relative humidity measured by the humidity sensor is above a pre-determined threshold;
- responsive to a determination that the relative humidity of the enclosed space is not above the pre-determined threshold, retain the damper in the closed position;
- responsive to a determination that the relative humidity of the enclosed space is above the pre-determined threshold, determine if a speed of the variable-speed indoor circulation fan can be reduced;
- responsive to a determination that the speed of variable-speed indoor circulation fan can be reduced, reduce the speed of the variable-speed indoor circulation fan in an effort to increase latent capacity of the HVAC system; and
- responsive to a determination that the speed of the variable-speed indoor circulation fan cannot be reduced, signal the damper to move to the open position to reduce a volume of air supplied to the enclosed space to create an effect similar to that of reducing the speed of the variable-speed indoor circulation fan.

9. The HVAC system of claim 8, wherein the speed of a variable-speed indoor circulation fan is modulated responsive to a speed of a variable-speed compressor.

10. The HVAC system of claim 8, wherein, when moving the damper to the open position, a portion of the air discharged from the variable-speed indoor circulation fan travels through the bypass duct to the return air duct and is not discharged to the enclosed space via the supply air duct.

11. The HVAC system of claim 8, wherein, when the HVAC system operates in the air-conditioning mode, the HVAC system further operates in one of a cooling mode and a dehumidification mode.

12. The HVAC system of claim 8, comprising a bypass humidifier fluidly coupled to the supply air duct and the bypass duct.

13. The HVAC system of claim 12, wherein the bypass humidifier comprises a wet, evaporative pad.

14. The HVAC system of claim 8, wherein, when moving the damper to the open position, a portion of the air discharged from the variable-speed indoor circulation fan travels through the bypass duct to the return air duct and is not discharged to the enclosed space thereby increasing a latent capacity of the HVAC system.

15. A method of operating an HVAC system, the method comprising:
determining, using an HVAC controller, if the HVAC system is operating in a heating mode or an air-conditioning mode;
responsive to a determination that the HVAC system is operating in the heating mode, opening a damper arranged in a bypass duct that fluidly couples a supply air duct to a return air duct;
responsive to a determination that the HVAC system is operating in the air-conditioning mode, closing the damper;
determining, using the HVAC controller, if a relative humidity of an enclosed space is above a pre-determined threshold;
responsive to a determination that the relative humidity of the enclosed space is not above the pre-determined threshold, retaining the damper in a closed position;
responsive to a determination that the relative humidity of the enclosed space is above the pre-determined threshold, determining using the HVAC controller, if a speed of an indoor circulation fan can be reduced;
responsive to a determination that the speed of the indoor circulation fan can be reduced, reducing the speed of the indoor circulation fan; and
responsive to a determination that the speed of the indoor circulation fan cannot be reduced, opening the damper to reduce a volume of air supplied to the enclosed space to create an effect similar to that of reducing the speed of the variable-speed indoor circulation fan.

16. The method of claim 15, wherein opening the damper comprises directing air through a bypass humidifier.

17. The method of claim 16, wherein the bypass humidifier includes a wet, evaporative pad.

18. The method of claim 15, wherein the determining if the relative humidity of the enclosed space is above the pre-determined threshold comprises utilizing a humidity sensor disposed in the enclosed space.

19. The method of claim 18, wherein the humidity sensor is electrically coupled to the controller.

20. The method of claim 19, wherein the humidity sensor is electrically coupled to the controller via a wired connection.

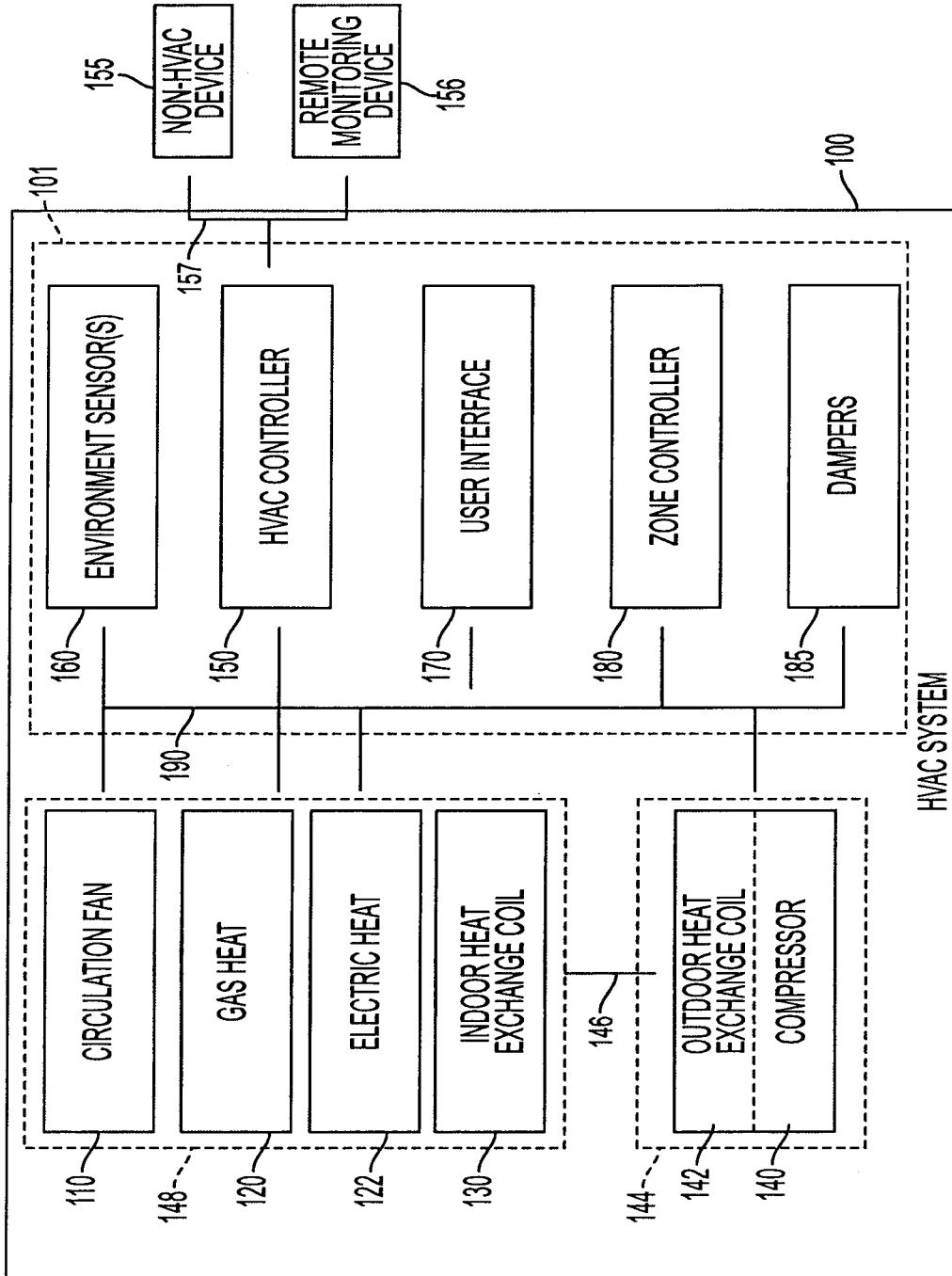

FIG. 1

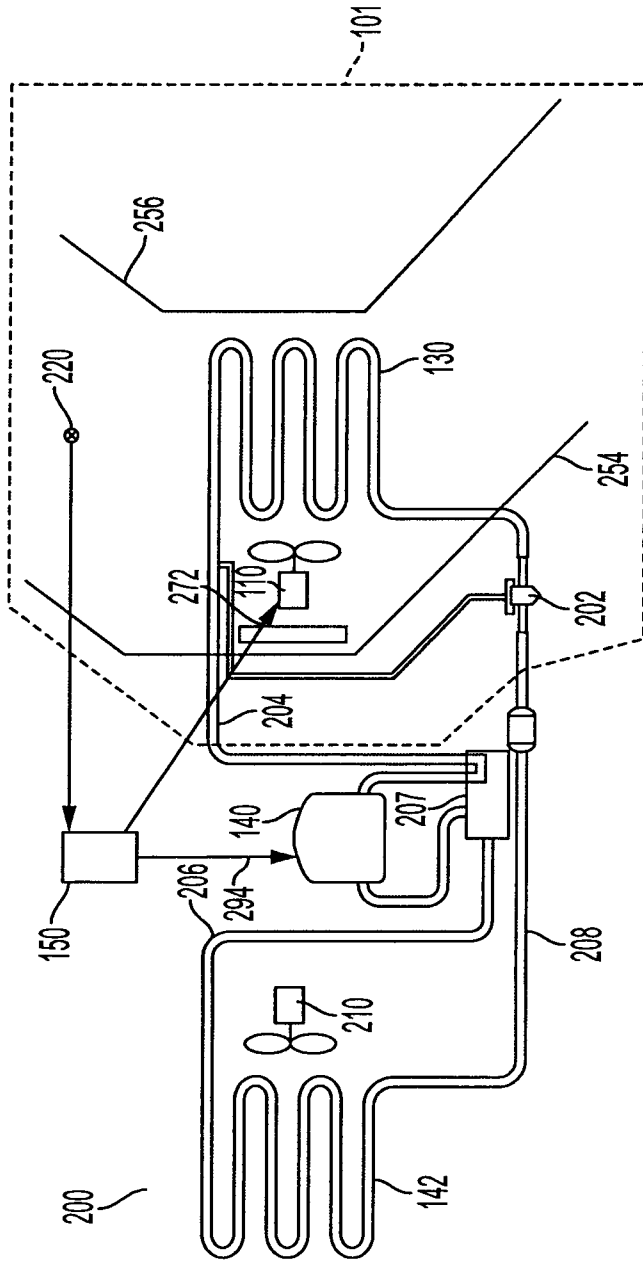

FIG. 2

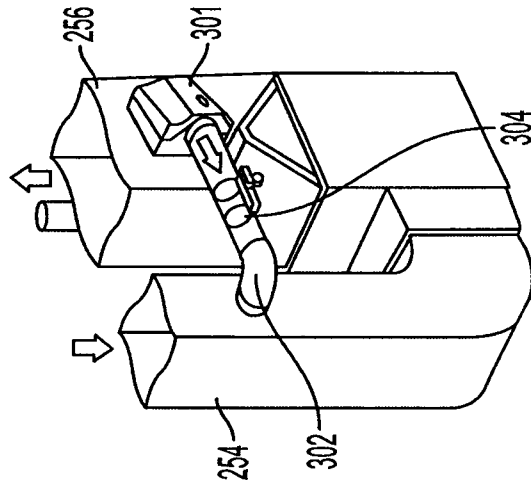

FIG. 4

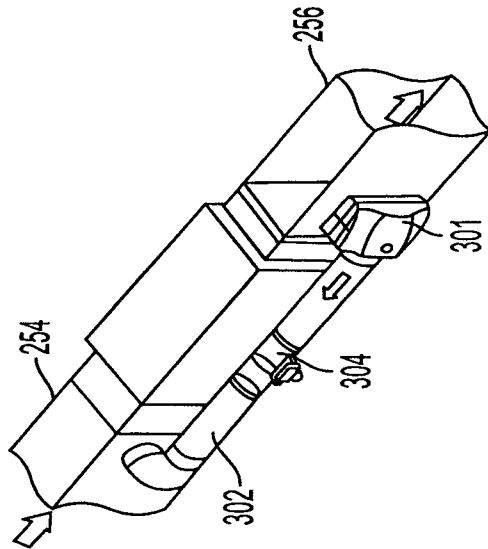

FIG. 3

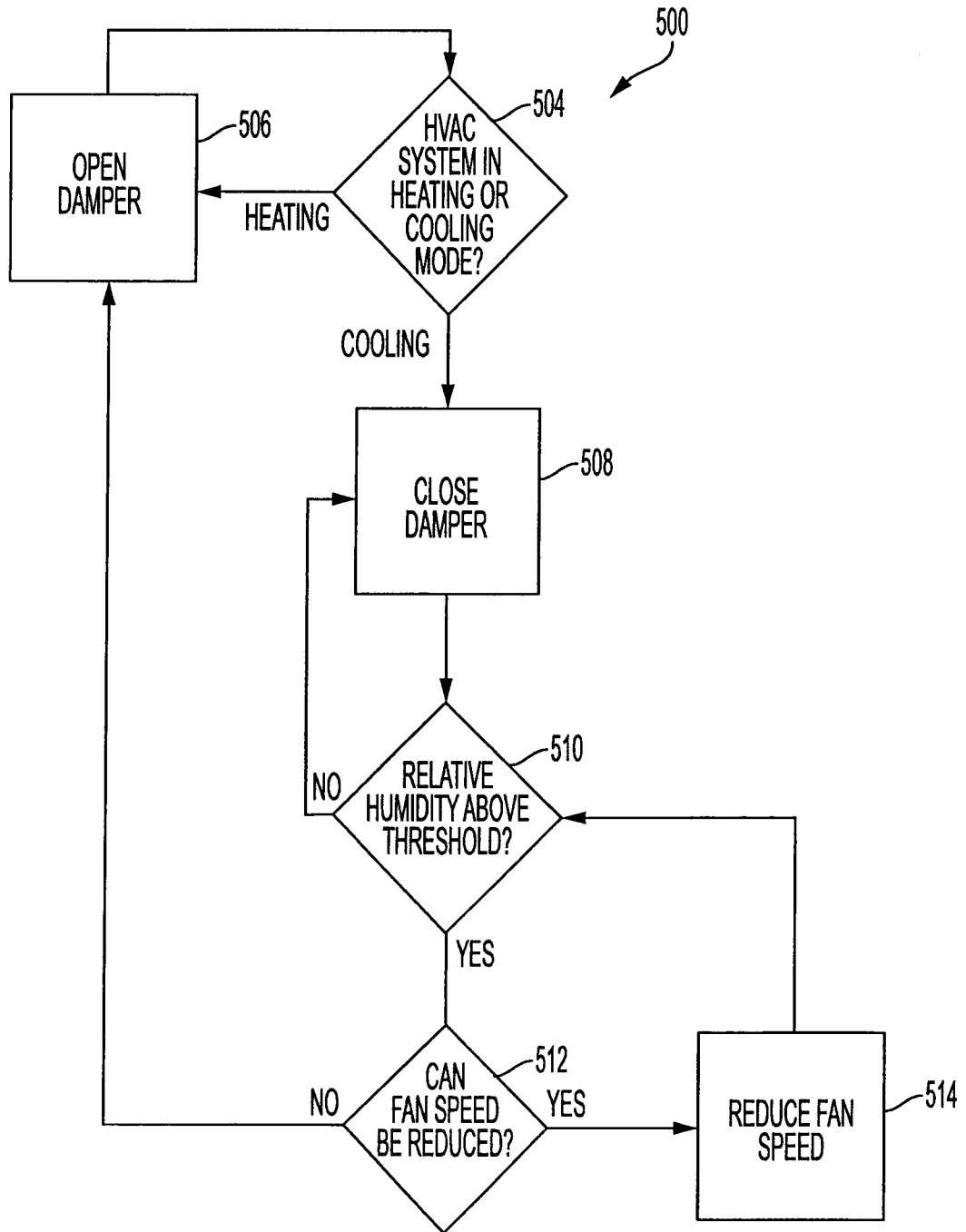

FIG. 5

