

(19)
(12)

(KR)
(A)

(51) 。 Int. Cl. ⁷
G02F 1/136

(11)
(43)

2002 - 0031764
2002 05 03

(21) 10 - 2000 - 0062480
(22) 2000 10 24

(71) .
,
20

(72) 1145 640 - 1204
306 - 1101
1005 - 1403
408 - 301

(74)
:

(54)

가. :
.
:
, (Mo)/ (AlNd) , (Al) , ITO
가

(Ti), (In) 가 , (Mo), (Cr), (W), 가

4g

1

2 5

3

4a 4g 3 A - A', B - B', C - C'

5a, 5b (photo resist)

6a, 6b

< >

T : C :

P : 118 :

120 : 122 :

130 : 132 :

, ITO

가 가

ITO가

가

ITO

(Al)

(capacitor)

(Cr),

(Mo),

(W),

(Ti),

(In)

(capacitor)

(Al)

가

1

2

3

4
ITO

5

2

가

Cr)
st)

2

(
photo resi

3

(Cr), (Mo), (W), (Ti), (In)

3

, 가 (102) (103)

(116) (116) (117) (103)
(118)

(102) (116,118) (T)

(122), (103) 가 ()가
(132) (P)

(122) (132)

(122) (117)

(132) (122)

ITO

(122) (132) (122)
(106) (112) ITO

(103) (capactor) (104)

(104) (103)

(103)

(104)

(104) (104) ITO가
(103) (117)

(1

20)

4a 4g 3 A - A', B - B', C - C' 2

5

, A - A' , B - B' , C - C'

4a 2 ST1 (1) 1

(102), (104), (106)

4b 2 ST2 (102) (108)
 (110a ; a - Si) (110b ; n+ - a - Si)

4c (110a ; a - Si) (110b ; n+ - a - Si) (1
 10) (112 ; photo resist) (T),
 (C), (P)
 (T) (112) (T) 가 (C)
 (P) 6a

4d 2 ST3 (110) (111a)
 (112)가 (P) (106) 가
 (111a) (110b) (111b)
 (111b) (111a)
 (110) (106) 2

4e 2 ST4, 5 (104) (106) 3
 (116,118) (120) (P) (116,118)
 (122)
 (116,118) (110b) (T) (ch)
 (116,118)
 (Cr), (W), (Mo), (Ti), (In)

4f 2 ST6 (116,118) (124)
 4 (126) (127), (128)

4g 2 ST7 (124) ITO 5
 (130) (130) (126)
 (118) (127) (120)
 (130) (P) (122) (

132) 4c

5a, 5b (photo resist)

(1) (150) , (positive) (152
; photo resist) (170) , (T) (A)
(160) (170) (160) (17
0) (T) (152) , (160)
(A) (152) , 5b (170) (160)
(152)

(152)가 (152)
(150) , (150) (

(162) ,
6a, 6b
5a (210) (I),
(II), (III) (200)
(II) (206)
(I) (201) , (206)
(201)

(I) (206) (201)
6b 가 가 (6a 200) (210)
(252)

4c 6b I, II, III
(4c T), (4c C), (4c P)
(4c 112)
(210) (252) (1) (250)
(4c 110)
(200) (4c 111a) , (4c 106)

ITO

가

가

(57)

1.

(Al)

;

,

;

,

;

;

;

;

;

2.

1

,

(capacitor) ,

.

3.

1

,

(Cr), (Mo), (W), (Ti), (In)

.

4.

;

(Al) 가 1 (capacitor) ;

2

,

;

,

3 ;

4

;

ITO , 5

5.

4 ,

2 , , 가 ,

6.

4 ,

(Cr)
(photo resist)

7.

4 ,

2 , 3

8.

4 ,

, (Cr), (Mo), (W) , (Ti), (In)

1

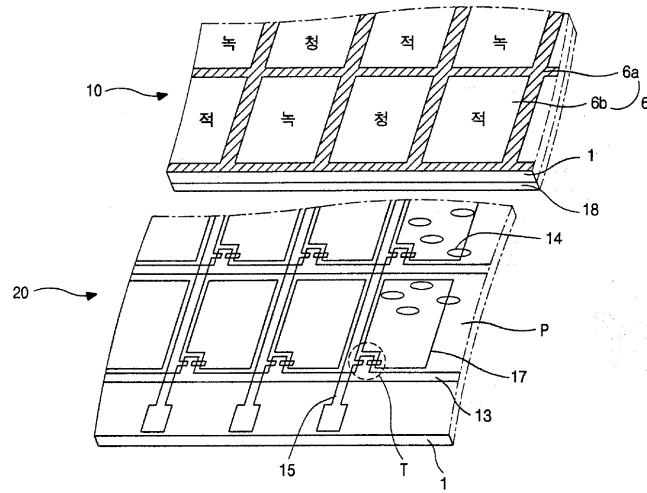

2

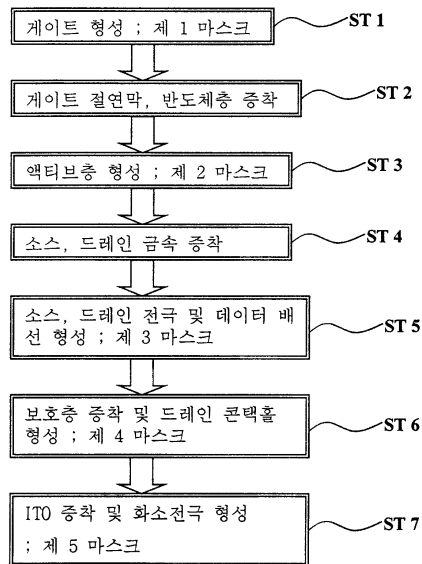

3

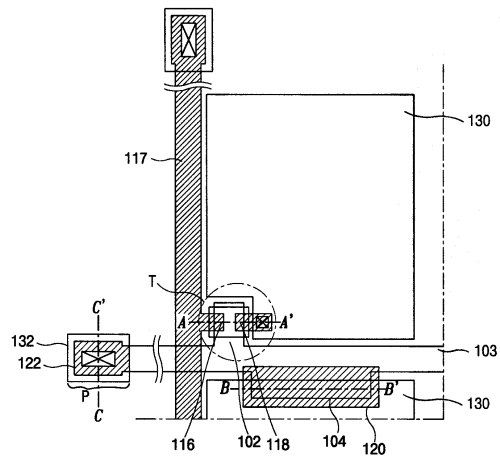

4a

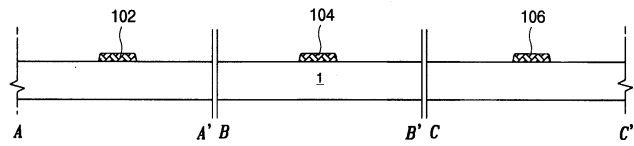

4b

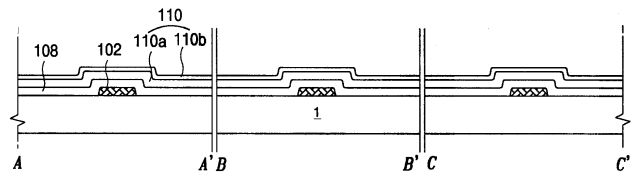

4c

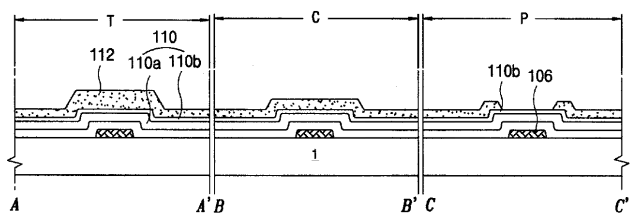

4d

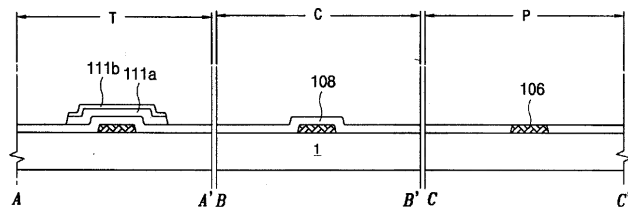

4e

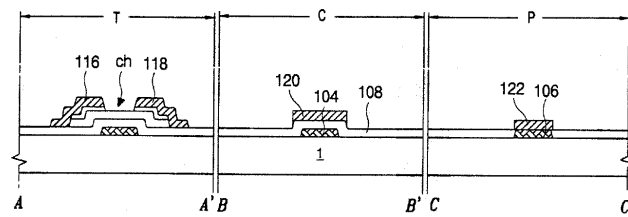

4f

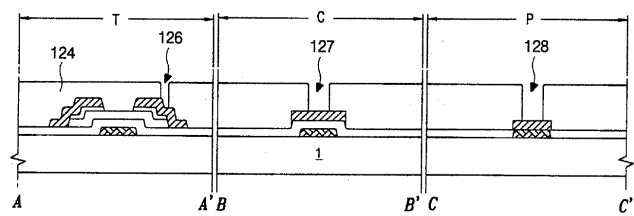

4g

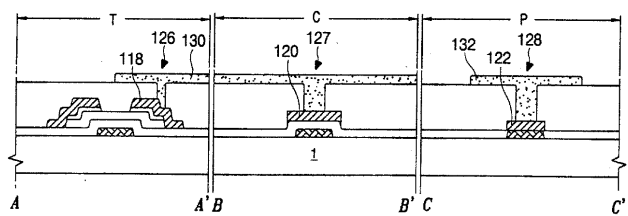

5a

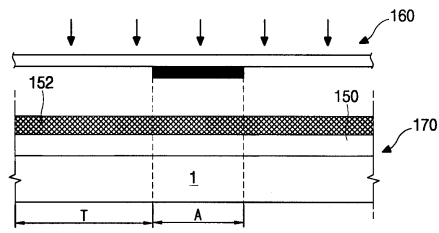

5b

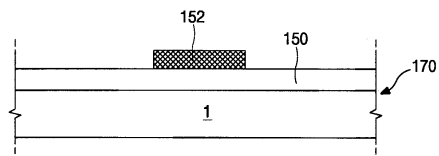

6a

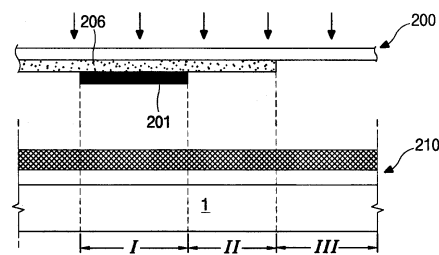

6b

