

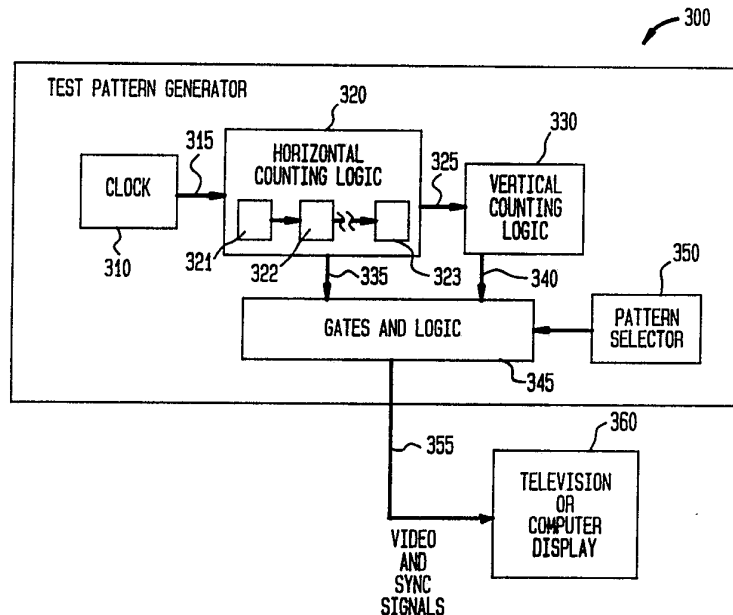

INTERNATIONAL APPLICATION PUBLISHED UNDER THE PATENT COOPERATION TREATY (PCT)

(51) International Patent Classification ⁵ : H04N 17/04	A1	(11) International Publication Number: WO 92/20195 (43) International Publication Date: 12 November 1992 (12.11.92)
<p>(21) International Application Number: PCT/US92/03560</p> <p>(22) International Filing Date: 30 April 1992 (30.04.92)</p> <p>(30) Priority data: 694,878 2 May 1991 (02.05.91) US</p> <p>(71) Applicant: CACTUS COMPUTERS, INC. [US/US]; 4 Robin Road, Rumson, NJ 07760 (US).</p> <p>(72) Inventor: SONEIRA, Raymond, M. ; 4 Robin Road, Rumson, NJ 07760 (US).</p> <p>(74) Agent: MICHAELSON, Peter, L.; Stanger, Michaelson, Spivak & Wallace, Parkway 109 Office Center, 328 Newman Springs Road, P.O. Box 8489, Red Bank, NJ 07701 (US).</p>	<p>(81) Designated States: AT (European patent), BE (European patent), CA, CH (European patent), DE (European patent), DK (European patent), ES (European patent), FR (European patent), GB (European patent), GR (European patent), IT (European patent), JP, KR, LU (European patent), MC (European patent), NL (European patent), SE (European patent).</p> <p>Published <i>With international search report.</i></p>	

(54) Title: TECHNIQUE FOR DETECTING COLOR MISREGISTRATION AND MISCONVERGENCE



(57) Abstract

A blinking set (40, 50) of displayed collinear elements (41, 43, 45, 51, 53, 55) alternating in color allows simple, rapid, and accurate determination of color misregistration or misconvergence in color television video displays (360, 470) and color television cameras. Operators can readily detect misconvergence due to a shift in a trend line (98) of the collinear elements which is made quite noticeable by repeatedly switching between two patterns (40, 50), thereby introducing an apparent blinking motion of the misaligned elements in displayed areas that are misconverged. The blinking motion can also be detected by automatic means (630), thereby eliminating the need for an operator.

FOR THE PURPOSES OF INFORMATION ONLY

Codes used to identify States party to the PCT on the front pages of pamphlets publishing international applications under the PCT.

AT	Austria	FI	Finland	MI	Mali
AU	Australia	FR	France	MN	Mongolia
BB	Barbados	GA	Gabon	MR	Mauritania
BE	Belgium	GB	United Kingdom	MW	Malawi
BF	Burkina Faso	GN	Guinea	NL	Netherlands
BG	Bulgaria	GR	Greece	NO	Norway
BJ	Benin	HU	Hungary	PL	Poland
BR	Brazil	IE	Ireland	RO	Romania
CA	Canada	IT	Italy	RU	Russian Federation
CF	Central African Republic	JP	Japan	SD	Sudan
CG	Congo	KP	Democratic People's Republic of Korea	SE	Sweden
CH	Switzerland	KR	Republic of Korea	SN	Senegal
CI	Côte d'Ivoire	LI	Liechtenstein	SU	Soviet Union
CM	Cameroon	LK	Sri Lanka	TD	Chad
CS	Czechoslovakia	LU	Luxembourg	TG	Togo
DE	Germany	MC	Monaco	US	United States of America
DK	Denmark	MG	Madagascar		
ES	Spain				

|

**TECHNIQUE FOR DETECTING COLOR MISREGISTRATION AND
MISCONVERGENCE**

5 FIELD OF THE INVENTION

 This invention relates a technique for
detecting misalignment among separate color component
images produced by a color video display or color video
10 camera.

BACKGROUND OF THE INVENTION

 In most color video input and output devices,
15 each primary color that is being scanned or displayed is
processed separately. For example, in a color television
camera, special optics that include appropriate color
filters separate incoming light into its red, green, and
blue components, which are then separately imaged onto
20 three monochrome camera sensors. In a projection
television display, three Cathode Ray Tubes (CRTs) or
Liquid Crystal Display (LCD) light valves are used to
separately generate monochrome red, green, and blue
images, which are then combined together using special
25 optics. In a computer display or television receiver
with a color CRT, three separate electron beams are used
to excite red, green, and blue phosphors on the screen.

 In order to properly reproduce a complete video
30 image, each of the red, green and blue component color
images must be properly aligned with respect to the other
such images, so that all these component images will, to
a viewer, fuse together into a single displayed color
image. This alignment is called color registration or
35 color convergence. In general, color registration is
difficult to achieve because of the effects of optical
system geometry, optical errors, alignment errors, and

nonlinearities in the camera or display devices themselves. For example, in magnetically deflected camera sensors and CRTs, difficulties inherent in precisely and accurately generating proper magnetic fields result in different geometric errors for each primary color. The geometric errors alter a positional correspondence among the primary color images, and therefore adversely affect the color registration. For example, in a 30 inch (approximately 33 cm) (diagonal) television or computer display, a one percent geometric distortion error in only a red channel image will cause portions of the red image to be shifted approximately 0.08" (2 mm) with respect to green and blue channel images. Such a displacement is readily apparent to a viewer. In general, color convergence is never perfect everywhere in the image, and the degree of alignment will generally vary significantly throughout the image. A common practice is to adjust for optimum convergence at the center of the image, i.e., as close to perfect as can be achieved there. Elsewhere the degree of alignment will generally degrade towards the sides and corners of the image, often reaching a maximum at some point along the periphery. This lack of color registration and convergence is called color misregistration or misconvergence.

The effects of color misregistration adversely affect an image in various ways, for example, elements drawn in secondary colors (combinations of the primary colors) will have color variations that are called color fringes. For example, referring to FIGs. 1B and 1C, yellow line 14 drawn on a CRT display screen with misregistered red and green components will have red fringe border 17 on one side, central yellow portion 16, and green fringe border 18 on the other side. As such, the image containing such a line will appear to the viewer to be blurred or out of focus. Furthermore, there

will also be a loss of detail in the displayed image because the misregistered components are positionally shifted into adjoining areas, which, in turn, broadens local image detail and causes it to overlap with other image detail. When the misregistration is greater than the line width, separate offset images will appear. These problems are especially serious for High Definition Television (HDTV) and computer displays, where fine image detail, graphics and text characters are often viewed closely by a user.

Most prior art methods for detecting color misregistration use a crosshatch and dot pattern that are drawn, e.g. on a CRT display screen, in a single secondary color. Such a pattern is shown in FIG. 1A. As shown, the pattern contains vertically ruled lines, collectively identified as lines 11, which are useful for detecting color fringing in the horizontal direction, horizontally ruled lines, collectively identified as lines 12, which are useful for detecting color fringing in the vertical direction, and dots, of which dot 13 is illustrative, which are useful for detecting color fringing in either direction. In use, a trained operator examines an image containing a displayed crosshatch and dot pattern for color fringing and makes appropriate adjustments to minimize the misalignment. The procedure is generally performed for each of the secondary colors: yellow, cyan, and magenta in order to test for red-green, blue-green, and red-blue misalignment. With such a crosshatch and dot pattern, the color fringes tend to be difficult to detect because they are often just slivers of light that are not as bright as a centrally aligned secondary color. The primary colors also have different visibilities, for example, blue is difficult to see next to green or red. Also, because of a smooth Gaussian profile of the electron beams used in the CRT display, a misregistration produces a gradual smooth transition to

and from the color fringes, making these fringes more difficult to spot than an abrupt and sharp transition. As such, since the operator just scan the image for rather minute color fringes, this process for detecting
5 misregistration using a crosshatch and dot pattern tends to be quite slow and exhibits a low sensitivity to misconvergence and misregistration.

Many automated methods for measuring
10 misregistration separately and successively determine centroids for key areas of a monochromatic test pattern in each of the red, green, and blue primary colors. See, for example, U.S. patents 4,635,095 and 4,988,857. These methods are generally slow and require expensive test
15 equipment. Moreover, time lag between a sequential measurement of the centroids of each separate color image introduces inaccuracies because of instabilities and drift in the scanning circuits of the camera or display. Other methods actively shift or offset a scanning pattern
20 in order to measure misconvergence. See, for example, U.S. patents 4,642,529 and 4,686,429. These latter methods require that: (a) expensive test equipment be used, and (b) various modifications be made to the scanning circuits in a display device in order for these
25 methods to be used. Since the scanning pattern will necessarily be altered, misregistration tests based upon these latter methods cannot be performed on a device that has not been so modified, i.e. a device that is in normal working order.

30

SUMMARY OF THE INVENTION

Accordingly, an object of my inventive
technique is to provide a method for detecting color
35 misregistration and color misconvergence where an operator, readily and almost effortlessly, visually detects those areas on the display screen that are out of

alignment without having to undertake a detailed visual search of an entire displayed image.

Another object of my inventive technique is to
5 reduce the likelihood that the operator will overlook areas of the displayed image that are out of misalignment.

A further object of my inventive technique is
10 to reduce the subjective nature of the operator's visual inspection of the displayed image for misalignment.

An additional object of my inventive technique
15 is to increase the visibility of various misregistered colors, such as blue, that are difficult for the operator to see.

Yet another object of my inventive technique is
20 to reduce the time needed for an operator to detect misconvergence as well as to increase the sensitivity and accuracy of the determination.

These and other objects are accomplished, in
25 accordance with my inventive teachings, by using color collinearity and blinking motion to detect and subsequently minimize color misregistration in an image. Specifically, in color collinearity, a line made up of multiple sets of alternating primary colors is produced on a television or display using a camera signal or test
30 pattern generator. Because of misregistration and misconvergence, the line will not appear to be a single smooth line, but rather have a somewhat jagged appearance. A human eye is particularly good at locating a trend line in each individual segment and in detecting
35 small shifts in the collinearity of adjacent segments. In addition, by visually connecting the trend lines from multiple sets of like colored segments, a viewer's

sensitivity to detecting shifts is further increased. Both of these features advantageously impart a high degree of sensitivity into the collinear pattern to misregistration and misconvergence. The line segments
5 are not required to have the same thickness or intensity. Note that there is no color blending or overlap, either of which reduces sensitivity.

Sensitivity is further enhanced by introducing
10 blinking, where the colors in the segments are repeatedly switched in time from alternating colors to a single common color and then switched back again to alternating colors. The single common color is the color that appears dimmest to the human eye. For example, blue is
15 the common color for green-blue or red-blue patterns; red is the common color for red-green patterns. The time period during which the single common color appears provides a baseline visual reference for perfect registration. If the other colors are not perfectly
20 registered with a baseline color, then the eye will see apparent movement of the blinked line segments (hereinafter referred to as "blinking motion") each time the colors change. This calls the viewer's, i.e. an operator's, attention to the misregistered segments and
25 further increases the sensitivity to misregistration and misconvergence. The operator's detection of such blinking motion is automatic and involuntary because the eye is especially sensitive to movement in the visual
field.

30

In an alternate embodiment, the operator is replaced by automatic signal processing circuitry in which amplitude and relative timing of the red, green and blue video signals that depict the pattern, such as those
35 generated by a camera imaging the pattern displayed on a CRT display under test, are analyzed using electronic circuitry. The blink rate can be the frame rate of the

video signal, normally about 60 Hz. High speed blinking establishes an accurate baseline signal from which a misconvergence offset signal can be accurately detected with high sensitivity. Rapid permutations of the segment colors allow all combinations of the primary colors to be measured virtually at the same time.

BRIEF DESCRIPTION OF THE DRAWINGS

10 In order that my invention may be fully understood, the preferred embodiments will be described with reference to the accompanying drawings, in which:

15 FIG. 1A shows a prior art crosshatch and dot pattern on a display screen 10;

 FIGS. 1B and 1C show enlarged sections of a line, in the prior art pattern shown in FIG. 1A, in perfect and imperfect registration, respectively;

20 FIG. 2A shows vertical lines 21 generated on a display screen 20 wherein such lines are divided into segments with alternating colors in accordance with my inventive technique;

25 FIGS. 2B and 2C show enlarged sections of lines 23 and 24 in perfect and imperfect registration, respectively, within lines 21 shown in FIG. 2A;

30 FIGS. 3A, 3B, and 3C show blinking motion for perfect and imperfect registration in various lines that form part of the vertical lines 21 shown in FIG. 2A and in accordance with my inventive technique;

35 FIG. 4 shows a test pattern generator for producing blinking collinear segmented lines on a television or computer display;

FIG. 5 shows a video camera 420 imaging test chart 500 and test pattern switcher 400 for producing blinking collinear segmented lines on monochrome or color display 470 that is used to evaluate registration and convergence of the camera in accordance with my inventive technique;

FIG. 6A shows apparatus for automatically measuring misregistration of a color television camera in accordance with my inventive teachings;

FIG. 6B shows apparatus for automatically measuring misregistration of a color display also in accordance with my inventive teachings;

FIG. 7 shows overlapping oscilloscope traces 710 and 720 from blinking colors that are misregistered; and

FIG. 8 shows amplitudes of a video signal at a specified time offset (horizontal position) on each of several scan lines (i.e. a vertical slice) for a horizontal line imaged by a camera as several horizontal scan lines.

25

DETAILED DESCRIPTION

A. Color Collinearity

This discussion will begin with color collinearity as embodied in my invention. Referring to FIG. 2A, seven vertical lines, collectively identified as lines 21, are generated on display screen 20. Each line is divided into 21 segments that have alternating primary colors, for example, red and green, as in the figure.

35

FIG. 2B shows an enlarged section of one of the lines, for example, line 23, with several segments, 25 through

30, in perfect registration. FIG. 2C shows an enlarged section of one of the lines, for example, line 24, with several segments, 31 through 36, misregistered in the horizontal direction. An operator viewing this pattern on display screen 20 determines a degree of misregistration or misconvergence of the display from the jaggedness of the displaced lines. Shifts as small as one-tenth of a line width are visually detectable. This procedure is depicted and examined for each combination of primary colors: red-green, green-blue, and red-blue. This procedure only needs to be performed for two primary color combinations inasmuch as the procedure becomes redundant for the third color combination. To investigate misregistration and misconvergence in the vertical direction, seven similar, but horizontally oriented lines are similarly generated and evaluated.

FIG. 4 shows apparatus necessary to generate these test patterns on a television or computer display. Clock 310 operates at a frequency that is approximately 25 times a horizontal scanning frequency. Horizontal counting logic 320 counts from the values "0" to "24". The values from "0" to "20" define an active scan line; values "21" through "24" are used for horizontal retrace and synchronization. Output 325 of horizontal counting logic 320 drives vertical counting logic 330, the latter counting from the values "0" to $n-1$, where "n" is the total number of scan lines per frame. Parallel outputs 335 and 340 from horizontal and vertical counting logic 320 and 330, respectively, drive well-known gates and logic 345, which generates synchronization and video test signals. For example, to generate seven horizontal lines in a frame with 481 viewable scanlines, circuitry in gates and logic 345 is arranged to produce a true ON logic value for vertical counter states 0, 80, 160, 240, 320, 400, 480, which produces a one volt video signal for display 360. For all other lines the video signal is set

OFF, i.e., zero volts, which is black. The output of a first stage of a horizontal binary counter 321 is used to specify the color in the gates and logic 345. A logical value of OFF corresponds to color1; a logical value of ON
5 corresponds to color2. Pattern selector 350, which is normally a switch under human operator control, specifies which of the three primary colors is activated by the color1 signal and the color2 signal. For example, if color1 is red and color2 is green, each of the seven
10 horizontal lines will have 21 color segments that alternate between red and green. Similar logic is used to generate seven vertical lines. The video controller of most computer displays can also be configured to produce this pattern.

15

FIG. 5 shows apparatus necessary to generate these test patterns for evaluating misregistration and misconvergence in a color camera. The camera is focused on test chart 500 that is all black except for seven
20 vertical white lines of which line 501 is illustrative. The seven lines should fill an image produced by the camera as completely as possible, with line 501 positioned close to the left edge of the image and line 507 positioned close to the right edge of the image.
25 The separate red, green, and blue signals from the camera are sent through test pattern switcher 400. At any instant the switcher blocks two of the three primary colors and passes the remaining color selected for the current screen position to the video display. The
30 functioning of the switcher is identical to the test pattern generator of FIG. 4 except that gates and logic 430 now switch camera color signals 425 on and off rather than generate the signals internally as in gates and logic 345 in FIG. 4. As shown in FIG. 5, output
35 signals 433 of switcher 400 are fed to television display 470. Synchronization locking circuits 435 align horizontal and vertical phases of the test pattern

11

switcher to the camera input signal. The operation of the synchronization locking circuits is well-known and therefore is not shown or described hereinafter. The video display can be either color or monochrome. If the display is monochrome, the three primary color signals are combined into a single monochrome signal using well-known standard methods. A color display is not necessary because nearly any amount of jaggedness of any misregistered or misconverged lines is readily seen by an operator and the color identity of the segments is already known unambiguously. In fact, a monochrome display is preferred because a color display will itself have misregistration and misconvergence that will introduce errors in the analysis of the camera signal.

15

B. Blinking Motion

The discussion will now proceed with the addition of blinking motion to the collinear line pattern in accordance with my invention. Reference is now made to FIGs. 3A-3C. Blinking motion is achieved by repeatedly switching from an alternating color pattern to a single common color once a second, simultaneously for all color segments that differ from the single common color. Half of the segments maintain their color and the other half change their color. FIG. 3A shows three segments in a single common color line 40 and an alternating color line 50 which alternate in time between one another. With misregistration or misconvergence present, red segment 73, shown in FIG. 3B, that changes color to green segment 93, will appear to move in position, i.e., so called blinking motion, with a periodicity at the blinking rate. The operator's eye will be automatically drawn to the motion because the eye is especially sensitive to movement in the visual field. Segments 71 and 75 in FIG. 3B that do not change color when displayed as red segments 91 and 95 shown in FIG. 3B

form a baseline that acts as a stationary point of reference. Blinking is accomplished in the apparatus in FIGS. 4 and 5 by electronically controlling pattern selector 350 or 460 to automatically alternate once a second between two selectable patterns. Referring now to FIG. 3A, each of the selector patterns is identified by the two alternating colors being generated, color1 and color2. For example, in this figure, for color1, segments 41, 45, 51, and 55 are always red, while for color2, segments 43 and 53 are both selected as red for one second and then selected as green for the next second in a repeating sequence.

In an alternate embodiment shown in FIG. 6A, the operator can be replaced by automatic signal processing circuitry 630 in which amplitudes and relative arrival times of video signals are electronically measured. Test chart 600, camera 610, and test pattern switcher 620 are the same as chart 500, camera 420, and switcher 400 as shown in FIG. 5, respectively. The blink rate can be the frame rate of the video signal, normally about 60 Hz. For evaluating the registration of a color camera, the camera's own red, green, and blue video signals are used at output 625, as shown in FIG. 6A, of test pattern switcher 620. The three color signals are first combined in circuitry 630 into a single monochrome signal using well-known standard methods of signal addition. A monochrome signal is preferred because the color identity of the video signal is already known purely from the time of arrival of the signals, since only one primary color is activated at any given time. Use of only a single monochrome channel not only reduces the overall cost of the circuitry, but also increases the measurement accuracy because it is not necessary to cross-calibrate three separate color channels. For automatically evaluating registration of a color television or computer display, a monochrome camera 670

in FIG. 6B is used to image color display screen 660. Test pattern generator 650 is the same as generator 300 shown in FIG. 4. Test pattern switcher 620 shown in FIG. 6A is unnecessary in the embodiment shown in FIG. 6B since monochrome camera 670 is being used therein. In FIG. 6B, signal processing circuitry 690 is the same as circuitry 630 shown in FIG. 6A. The vertical retrace of the camera 670 shown in FIG. 6B must be synchronized to begin concurrent with a change in state of the signal that initiates the change in color blinking state of the test pattern generator 650. In both cases, the resulting monochrome signal is analyzed in the same way.

C. Misregistration

The discussion will now address misregistration in the horizontal direction. Horizontal misregistration is determined by vertical lines 21 as shown in FIG. 2A. To simplify the discussion I will consider one such vertical line, illustratively line 24 shown in FIG. 2C. The vertical position in the image is specified by a particular horizontal scan line number within the camera's raster. In principle, only one scan line at a time is examined, although in practice as many horizontal scan lines as desired can be analyzed by using high speed electronics to perform multiple measurements per image frame. The arrival time of a signal within a scan line, normally specified in micro-seconds between the start of a horizontal synchronization pulse and a peak of a video signal pulse, specifies horizontal position within the image. This time is measured using any one of many standard well-known techniques. Let t_1 be the arrival time before a blink, and t_2 be the arrival time after a blink. A difference in the arrival times before and after a color blink (i.e. $\Delta t = t_1 - t_2$) indicates a misregistration or misconvergence. Because 60 Hz blinking rapidly alternates between two states, this

difference in arrival time, Δt , can also be easily observed on an oscilloscope as two overlapping traces as shown in FIG. 7. The signal amplitude in this figure refers to the voltage of the monochrome signal derived from the output 625 of the test switcher 620 shown in FIG. 6A or the output 685 of monochrome camera 670 shown in FIG. 6B. Trace 710 refers to the signal before a blink and trace 720 refers to the signal after a blink. Because of the persistence of human vision and of the phosphors on the oscilloscope screen both traces appear to be present simultaneously, allowing a simple visual estimate of the difference in arrival times Δt . The misregistration Δd can be determined from the difference in arrival times. With Δt being the difference in arrival times, W the total length of a scan line (raster image width) in millimeters, and T the total time of a visible scan line not including the retrace time (raster image line time), then the misregistration Δd in millimeters is given by the equation (1) as follows:

$$\Delta d = \frac{\Delta t}{T} W \quad (1)$$

The peaks of the signals shown in FIG. 7 provide accurate single points of the reference for measuring arrival times t_1 and t_2 . Measuring times in terms of the occurrence of these peaks makes the time measurement independent of pulse amplitude and width, which means that the image brightness and line width of the red, green, and blue primary colors do not have to be the same. The most accurate method for measuring arrival time is to determine a centroid of the signal pulse using well-known digital sampling or analog techniques.

As to misregistration in the vertical direction, such misregistration is determined by horizontal lines, like lines 501 and 507 shown in FIG. 5, only oriented horizontally instead of vertically as in the figure. A shift in the vertical centroid position of

an imaged line before and after a blink is an indication of misregistration. To simplify the discussion we consider only one horizontal line instead of seven. The horizontal line seen by the camera is imaged as several
5 horizontal scan lines of varying intensities. In order to measure the vertical centroid of these scan lines at a given horizontal location within the image, an amplitude of the video signal is measured at a specified time offset from the horizontal synchronization pulse on each
10 scan line as shown in FIG. 8. The centroid can be calculated digitally as a weighted mean of the amplitudes. If A_i is the amplitude of scan lines S_i , then the centroid position C of the line is given by equation (2) as follows:

$$15 \quad C = \frac{\sum_i A_i S_i}{\sum_i A_i} \quad (2)$$

The centroid can also be determined using standard analog circuits. A difference in the position of the centroid before and after a color blink indicates a misregistration or misconvergence. Let C_1 be the
20 centroid position before a blink, and C_2 be the centroid position after a blink. If H is the raster image height in millimeters, and N is the number of visible image scan lines (not including vertical retrace), then the misregistration Δd in millimeters is given by
25 equation (3) as follows:

$$\Delta d = \frac{C_2 - C_1}{N} H \quad (3)$$

Alternatively, to evaluate the registration of a television or computer display, one can simply rotate the monochrome imaging camera by 90 degrees or use a second
30 camera oriented in that fashion and proceed exactly as in the case for the vertical lines discussed in the previous paragraph.

Clearly, it is readily apparent to those skilled in the art that, given my inventive teachings, many variations and modifications can be made to the present invention. For example, instead of using only
5 two alternating collinear elements, three or more alternating colors may be used. Furthermore, nearly any number of lines and segments can be used. Additionally, both horizontal and vertical blinking collinear elements may be present simultaneously. Further, the baseline
10 color and the blink rate may be varied, as desired. Also, diagonal and skew collinear elements may be used, and adjacent sets of collinear lines need not be parallel.

I claim:

- 1 1. Apparatus for detecting color misrepresentation and
2 misconvergence in a video camera (420) or video
3 display (360) comprising:
4 means (300) for generating first and second color
5 collinear patterns (40,50), wherein said first color
6 collinear pattern consists of a line having a single
7 color and said second color collinear pattern consists of
8 a line having a repeating pattern of successive color
9 line segments;
10 means (350,400) for periodically and alternately
11 selecting between said first and second color collinear
12 patterns; and
13 means (360,470) for displaying said selected
14 collinear pattern on a screen of a video display under
15 test (360) or on a screen of a video display (470)
16 connected to a video camera under test (420).
- 1 2. The apparatus as claimed in claim 1 wherein said
2 first color collinear pattern consists of a plurality of
3 like colored line segments (41,43,45) and wherein said
4 second color collinear pattern consists of said first
5 color collinear pattern having every other line segment a
6 different color (51,53,55) as compared to said color of
7 said first color collinear pattern.
- 1 3. The apparatus as claimed in claim 1 wherein said
2 pattern generating means further includes means (400) for
3 creating said patterns from video signals produced by
4 said video camera under test as the camera images a pre-
5 defined test pattern (500).
- 1 4. The apparatus as claimed in claim 1 further
2 including means (630) for detecting variations in said
3 display as said first and second color collinear patterns

4 are displayed, whereby said variations indicate color
5 misregistration and misconvergence.

1 5. The apparatus as claimed in claim 4 wherein said
2 line of said first and second patterns is vertically
3 oriented, and said detecting means further includes:
4 means (630) for measuring a first duration (710)
5 equivalent to the time required for a video scan line of
6 said video display under test or said camera under test
7 to reach a video signal maximum relative to a horizontal
8 synchronization pulse that begins said video scan line
9 during said first color collinear pattern generation,
10 means (630) for measuring a second duration (720)
11 equivalent to the time required for a video scan line of
12 said video display under test or said camera under test
13 to reach a video signal maximum relative to a horizontal
14 synchronization pulse that begins said video scan line
15 during said second color collinear pattern generation,
16 and
17 means (630) for calculating a difference (Δt) between
18 said first duration and said second duration, whereby
19 said difference indicates color misregistration and
20 misconvergence.

1 6. The apparatus as claimed in claim 4 wherein said
2 first and second patterns are each horizontally oriented,
3 and said detecting means further includes:
4 means (630) for determining a first video signal
5 amplitude centroid position during said first color
6 collinear pattern generation,
7 means (630) for determining a second video signal
8 amplitude centroid position during said second color
9 collinear pattern generation, and
10 means (630) for calculating a difference between
11 said first centroid position and said second centroid
12 position, whereby said difference indicates color
13 misregistration and misconvergence.

1 7. The apparatus as claimed in claim 1 wherein said
2 first pattern consists of a line having a single primary
3 color and said second pattern consists of a repeating
4 pattern of alternating primary color line segments.

1 8. The apparatus as claimed in claim 1 wherein said
2 first pattern consists of a line having a single primary
3 color and said second pattern consists of a repeating
4 pattern of color line segments having a plurality of
5 colors.

1 9. A method for detecting color misrepresentation and
2 misconvergence in a video camera or video display
3 comprising the steps of:
4 generating first and second color collinear
5 patterns, wherein said first color collinear pattern
6 consists of a line having a single color and said second
7 color collinear pattern consists of a line having a
8 repeating pattern of color line segments;
9 periodically and alternately selecting between
10 said first and second color collinear patterns; and
11 displaying said selected collinear pattern on a
12 screen of a video display under test or on a screen of a
13 video display connected to a video camera under test.

1 10. The method as claimed in claim 8 wherein said
2 generating step further includes the steps of:
3 generating said first color collinear pattern
4 consisting of a line having a plurality of like colored
5 segments; and
6 generating said second color collinear pattern by
7 changing the color of every other colored segment of said
8 first color collinear pattern.

1 11. The method as claimed in claim 9 wherein said
2 pattern generating step further includes the steps of
3 creating said patterns from video signals produced by

4 said video camera under test as the camera images a pre-
5 defined test pattern.

1 12. The method as claimed in claim 9 further including
2 the steps of detecting variations in said display as said
3 selected color collinear patterns are displayed, whereby
4 said variations indicate color misregistration and
5 misconvergence.

1 13. The method as claimed in claim 12 wherein said line
2 of said first and second patterns is vertically oriented,
3 and said step of detecting further includes the steps of:
4 measuring a first duration equivalent to the time
5 required for a video scan line of said video display
6 under test or said camera under test to reach a video
7 signal maximum relative to a horizontal synchronization
8 pulse that begins said video scan line during said first
9 color collinear pattern generation,
10 measuring a second duration equivalent to the time
11 required for a video scan line of said video display
12 under test or said camera under test to reach a video
13 signal maximum relative to a horizontal synchronization
14 pulse that begins said video scan line during said second
15 color collinear pattern generation, and
16 calculating a difference between said first duration
17 and said second duration, whereby said difference
18 indicates color misregistration and misconvergence.

1 14. The method as claimed in claim 12 wherein said first
2 and second patterns are each horizontally oriented, and
3 said step of detecting further includes the steps of:
4 determining a first video signal amplitude centroid
5 position during said first color collinear pattern
6 generation,
7 determining a second video signal amplitude centroid
8 position during said second color collinear pattern
9 generation, and

21

10 calculating a difference between said first centroid
11 position and said second centroid position, whereby said
12 difference indicates color misregistration and
13 misconvergence.

FIG. 1A
(PRIOR ART)

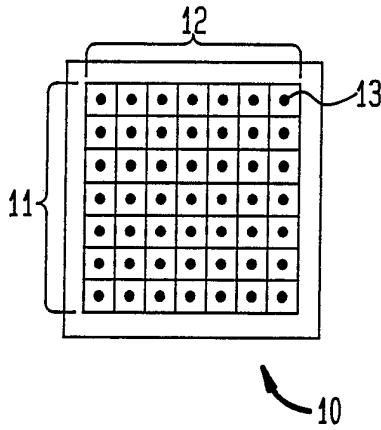

FIG. 1B
(PRIOR ART)



FIG. 1C
(PRIOR ART)

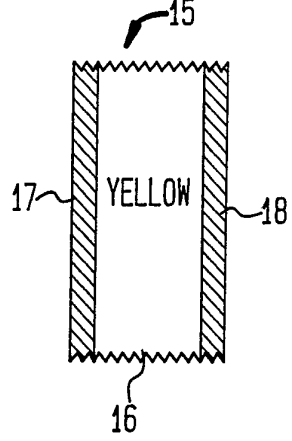

FIG. 2A

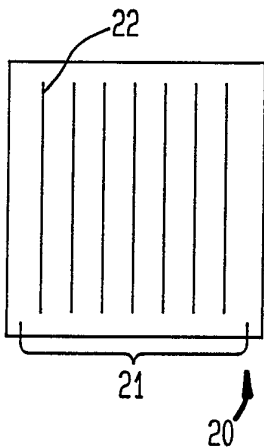

FIG. 2B

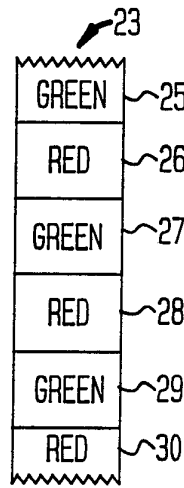

FIG. 2C

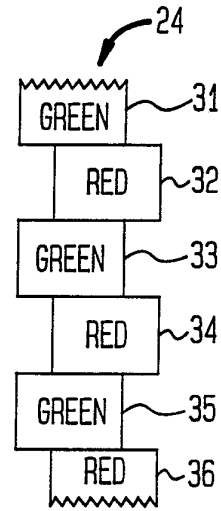

FIG. 3A

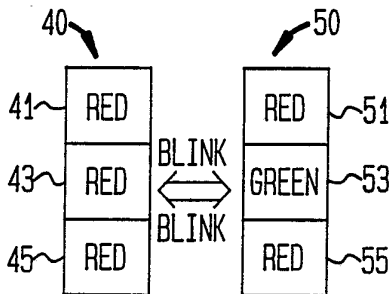

FIG. 3B

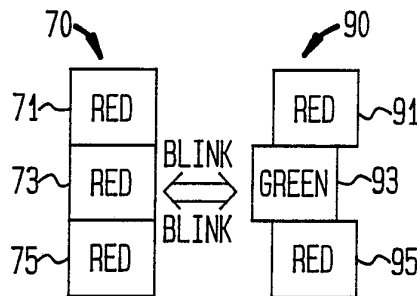

FIG. 3C

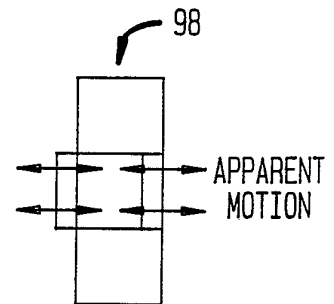

FIG. 4

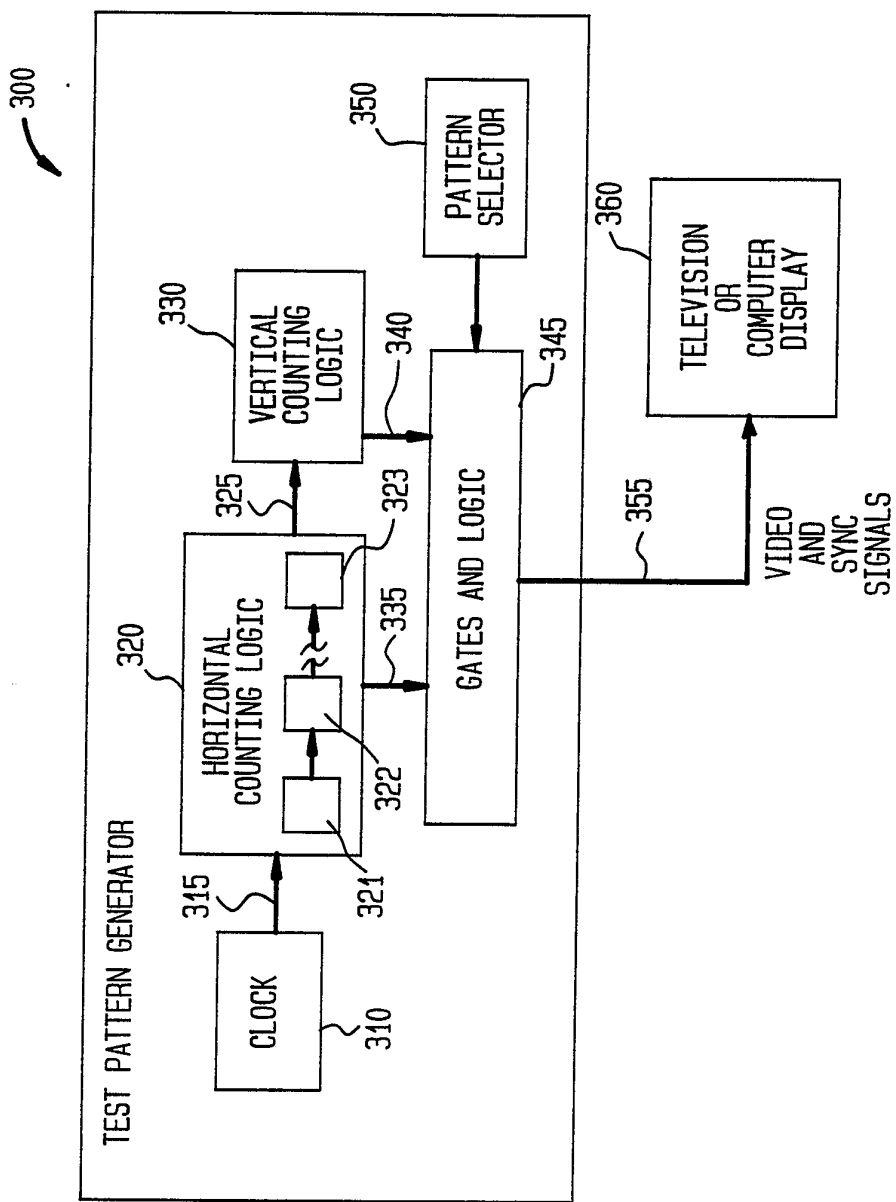

FIG. 5

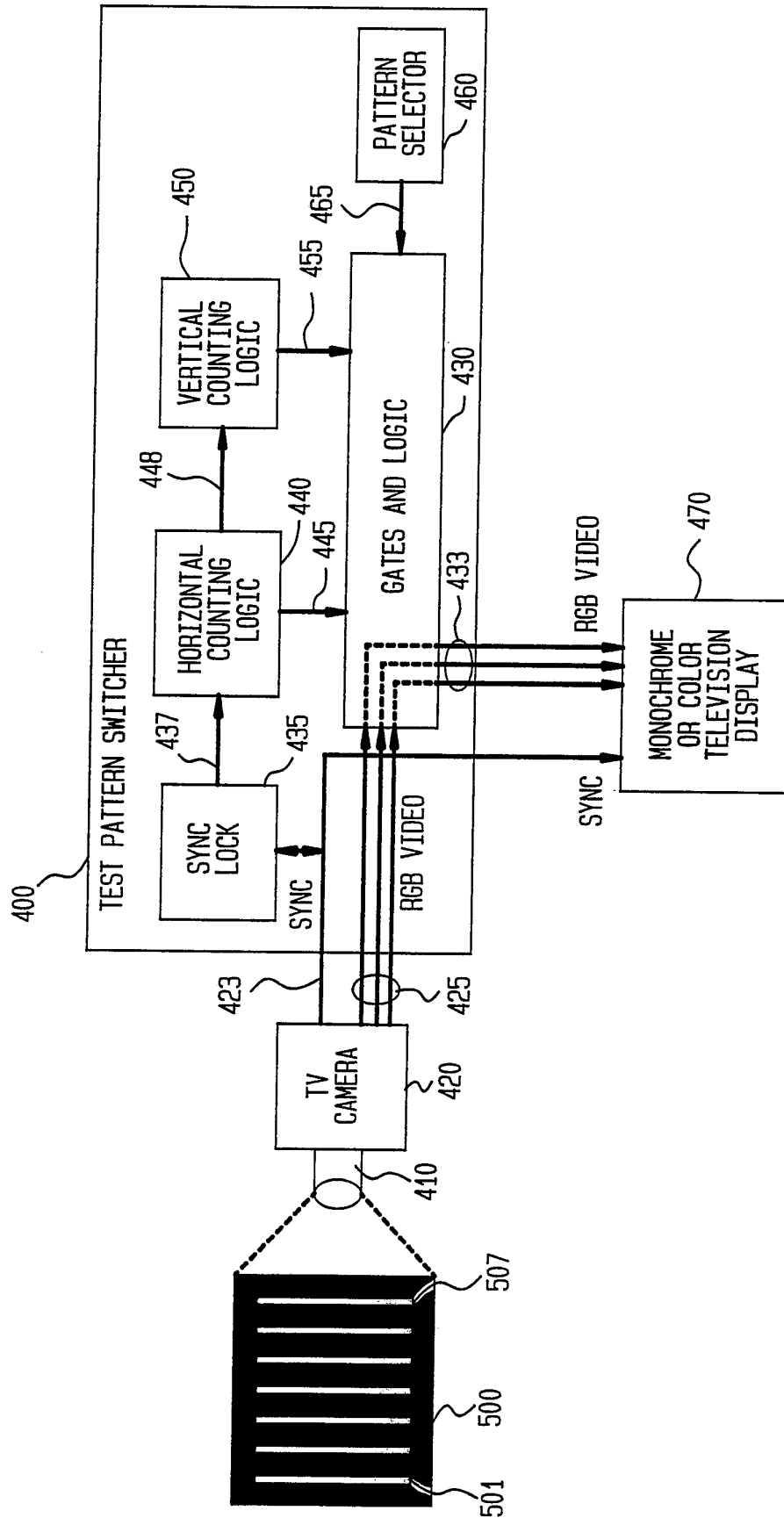

FIG. 6A

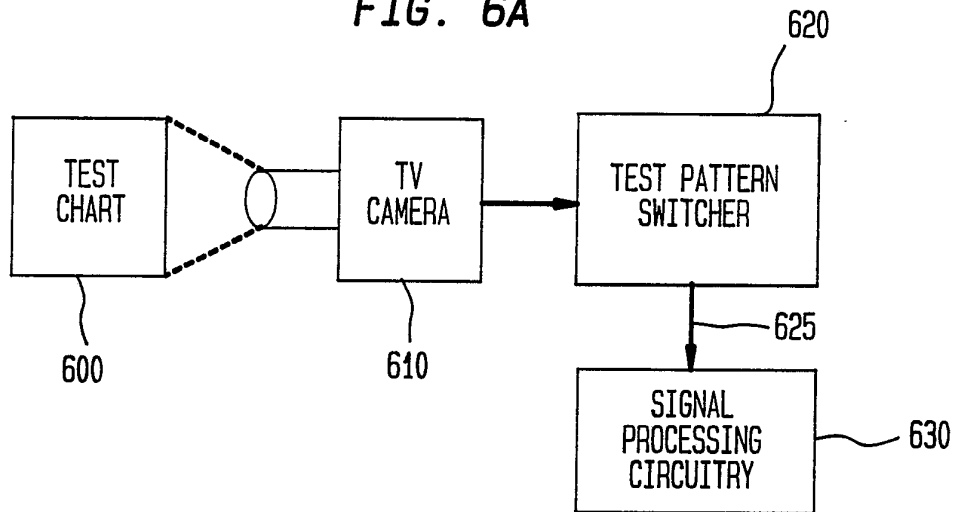

FIG. 6B

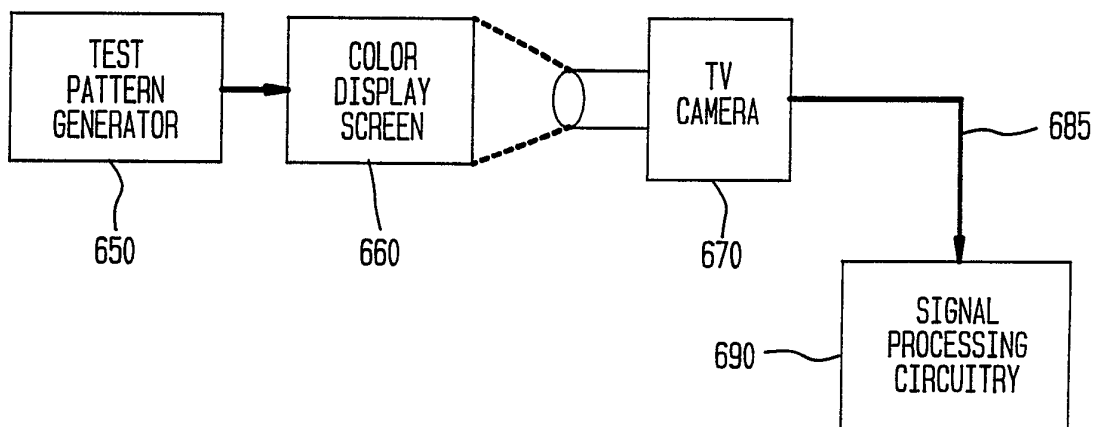

FIG. 7

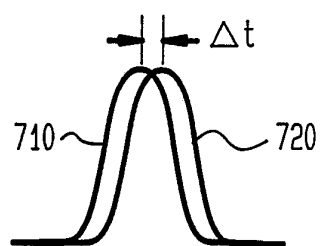
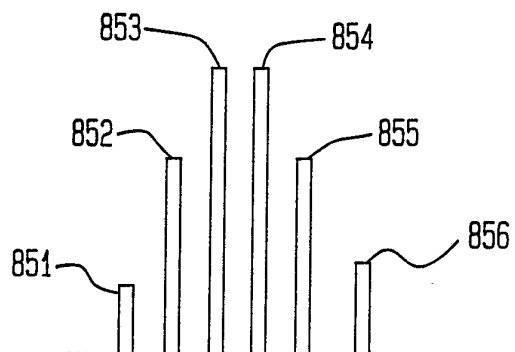

FIG. 8



INTERNATIONAL SEARCH REPORT

International application No.
PCT US92 03560

A. CLASSIFICATION OF SUBJECT MATTER

IPC(5) :H04N 17/04
US CL :358/10

According to International Patent Classification (IPC) or to both national classification and IPC

B. FIELDS SEARCHED

Minimum documentation searched (classification system followed by classification symbols)

U.S. : 358/65, 139; 315/368.11, 18

Documentation searched other than minimum documentation to the extent that such documents are included in the fields searched

Electronic data base consulted during the international search (name of data base and, where practicable, search terms used)

C. DOCUMENTS CONSIDERED TO BE RELEVANT

Category*	Citation of document, with indication, where appropriate, of the relevant passages	Relevant to claim No.
A	US, A, 4,316,211 (MACKEY ET. AL.) 16 February 1982, See entire document.	1-14
A	US, A, 3,916,437 (BARBIN) 28 October 1975, See entire document.	1-14
A	US, A, 2,594,383 (BEDFORD) 29 April 1952, See entire document.	1-14
A	US, A, 2,594,382 (BEDFORD) 29 April 1952, See entire document.	1-14
A	JP, A, 1-204,596 (SASAZAKI) 17 August 1989, See entire document.	1-14
A	JP, A, 3-85990 (KATO) 11 April 1991, See entire document.	1-14

Further documents are listed in the continuation of Box C. See patent family annex.

* Special categories of cited documents:	"T" later document published after the international filing date or priority date and not in conflict with the application but cited to understand the principle or theory underlying the invention
"A" document defining the general state of the art which is not considered to be part of particular relevance	"X" document of particular relevance; the claimed invention cannot be considered novel or cannot be considered to involve an inventive step when the document is taken alone
"B" earlier document published on or after the international filing date	"Y" document of particular relevance; the claimed invention cannot be considered to involve an inventive step when the document is combined with one or more other such documents, such combination being obvious to a person skilled in the art
"L" document which may throw doubts on priority claim(s) or which is cited to establish the publication date of another citation or other special reason (as specified)	"&" document member of the same patent family
"O" document referring to an oral disclosure, use, exhibition or other means	
"P" document published prior to the international filing date but later than the priority date claimed	

Date of the actual completion of the international search

11 JULY 1992

Date of mailing of the international search report

11 AUG 1992

Name and mailing address of the ISA/
Commissioner of Patents and Trademarks
Box PCT
Washington, D.C. 20231

Facsimile No. NOT APPLICABLE

Authorized officer

For MARK R. POWELL NGUYEN NGCC-RO
INTERNATIONAL DIVISION

Telephone No. (703) 305-4376