

(19) World Intellectual Property
Organization
International Bureau



(43) International Publication Date
9 September 2005 (09.09.2005)

PCT

(10) International Publication Number
WO 2005/082268 A1

- (51) International Patent Classification⁷: A61C 17/26, 17/34, 17/22, H01H 9/02 Alan, V. [US/US]; 17 Adams Drive, Cranbury, New Jersey 08512 (US). MOSKOVICH, Robert [US/US]; 20 Jensen Street, East Brunswick, New Jersey 08816 (US).
- (21) International Application Number: PCT/US2005/002124 (74) Agent: WOLIN, Harris, A.; COLGATE-PALMOLIVE COMPANY, 909 River Road, Piscataway, New Jersey 08855 (US).
- (22) International Filing Date: 21 January 2005 (21.01.2005)
- (25) Filing Language: English (81) Designated States (unless otherwise indicated, for every kind of national protection available): AE, AG, AL, AM, AT, AU, AZ, BA, BB, BG, BR, BW, BY, BZ, CA, CH, CN, CO, CR, CU, CZ, DE, DK, DM, DZ, EC, EE, EG, ES, FI, GB, GD, GE, GH, GM, HR, HU, ID, IL, IN, IS, JP, KE, KG, KP, KR, KZ, LC, LK, LR, LS, LT, LU, LV, MA, MD, MG, MK, MN, MW, MX, MZ, NA, NI, NO, NZ, OM, PG, PH, PL, PT, RO, RU, SC, SD, SE, SG, SK, SL, SM, SY, TJ, TM, TN, TR, TT, TZ, UA, UG, US, UZ, VC, VN, YU, ZA, ZM, ZW.
- (26) Publication Language: English
- (30) Priority Data: 10/763,621 23 January 2004 (23.01.2004) US
- (71) Applicant (for all designated States except US): COLGATE-PALMOLIVE COMPANY [US/US]; 300 Park Avenue, New York, New York 10022 (US).
- (72) Inventors; and (84) Designated States (unless otherwise indicated, for every kind of regional protection available): ARIPO (BW, GH,
- (75) Inventors/Applicants (for US only): SORRENTINO, [Continued on next page]

(54) Title: POWERED TOOTHBRUSH WITH TEST BUTTON

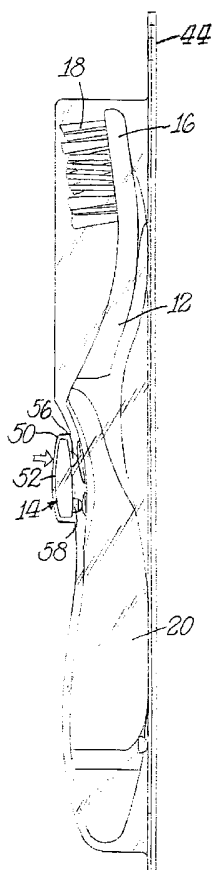

(57) Abstract: A powered operating device such as a powered toothbrush includes a test button for momentarily testing the operability of the device. The test button simultaneously presses against both the on portion and the off portion of the switch which controls the operation of the device. While pressure is applied to the test button, the device is placed in its operative condition and when the pressure is released, the geometric structure of the test button held by the package releases the on portion of the switch at the same time or just before the off portion. Thus, assuring that the switch turns off.

WO 2005/082268 A1



GM, KE, LS, MW, MZ, NA, SD, SL, SZ, TZ, UG, ZM, ZW), Eurasian (AM, AZ, BY, KG, KZ, MD, RU, TJ, TM), European (AT, BE, BG, CH, CY, CZ, DE, DK, EE, ES, FI, FR, GB, GR, HU, IE, IS, IT, LT, LU, MC, NL, PL, PT, RO, SE, SI, SK, TR), OAPI (BF, BJ, CF, CG, CI, CM, GA, GN, GQ, GW, ML, MR, NE, SN, TD, TG).

Declarations under Rule 4.17:

- *as to applicant's entitlement to apply for and be granted a patent (Rule 4.17(ii)) for all designations*
- *as to the applicant's entitlement to claim the priority of the earlier application (Rule 4.17(iii)) for all designations*

Published:

- *with international search report*
- *before the expiration of the time limit for amending the claims and to be republished in the event of receipt of amendments*

For two-letter codes and other abbreviations, refer to the "Guidance Notes on Codes and Abbreviations" appearing at the beginning of each regular issue of the PCT Gazette.

POWERED TOOTHBRUSH WITH TEST BUTTON

BACKGROUND OF THE INVENTION

For some powered items, such as a powered toothbrush, it is preferable for the consumer to be able to try to experience the function of the item before a purchase is made. Many powered items use a spring switch to provide the item with the ability to be turned on and off. In normal use of such items the user will press the "on" portion of the switch to activate and set the switch in the on position. Once in the on position the switch remains in this position until the "off" position is depressed to set the spring switch in the off position. Various attempts have been made to provide test structure, frequently referred to as "try me", in order to permit the user to test the operation of the item.

Some attempts have been made in the field of power toothbrushes to permit a prospective purchaser of a powered toothbrush to test the operability of the toothbrush. One of the concerns is that the testing should be of a momentary nature so that a tested toothbrush will not remain in its on or operating condition after the test. One approach that has been taken is to use a pressing movement of the switch for the momentary actuation and a sliding movement for the continuous operation. Examples of this approach are found in U.S. Patent Nos. 6,000,083, 6,189,693, 6,311,837, 6,371,294 and 6,564,940 and U.S. Published Patent Application Nos. 2001/0004781, 2001/0022277, 2002/0020645, 2002/0032941, 2002/0038772 and 2002/0078514. A disadvantage with this type of approach is that the user is required to use different motions for either testing or continuously operating the toothbrush.

A further approach at providing only momentary actuation for test purposes of a power toothbrush is to provide separate switches, one switch being for the test purposes giving momentary actuation and the other switch being for continuous operation. Examples of this approach are found in U.S. Published Application Nos. 2002/0017474 and 2002/0029988. A disadvantage with this approach is that the user must be careful as to which switch is being actuated. Other examples of providing power testing of toothbrushes and the like are found in U.S. Patent Nos. 4,925,025, 5,118,222 and 5,494,252 and in U.S. Published Application Nos. 2003/0000031, 2003/0066145,

2003/0135940 and 2003/0205492. Other examples include European Patent Application EP 0 587 406 and Japanese Application JP 402109226.

SUMMARY OF THE INVENTION

An object of this invention is to provide a toothbrush which includes a test button
5 for permitting a user to confirm the operability of the device.

A further object of this invention is to provide such a device having switch structure which includes an on position for continuously operating the device and an off position for inactivating the device.

A further object of this invention is to apply such techniques for the testing of the
10 operation of a powered toothbrush.

In accordance with this invention a powered operating device has a movable section which is moved in response to power transmitting structure from a power source. The device includes a switch structure having an on position for activating the power transmitting structure so that the movable section is in continuous operation until
15 inactivated by actuation of the switch structure at an off position. A test button is provided for simultaneously contacting both the on position and the off position of the switch structure when pressure is applied to the test button. This is accomplished in such a manner that while such pressure is being applied, the switch structure on position is activated to permit operation of the powered operating device. However, upon the release
20 of pressure because the test button had also been in contact with the switch structure at the off position the device is immediately inactivated.

In a preferred practice of this invention the switch structure is a spring of a rocker type nature wherein one portion of the spring would be pushed into contact with an electrical contact pin when in the on position and would remain in that position until
25 another portion of the spring is depressed at the off position to move the on position portion of the spring away from the contact pin. The test button functions in such a manner that when it is pressed against the spring the spring tends to flatten while the pressure is being applied which causes contact between the on position portion of the spring and the contact pin while still applying pressure at the off position. Upon release of
30 the test button the spring resumes only its off position condition wherein the on position portion no longer contacts the contact pin.

In a preferred practice of the invention the powered operating device is a powered toothbrush having cleaning elements such as bristles on a movable section of the cleaning head. The toothbrush could be packaged in a bubble container which is flexible in at least the portion of the bubble having the test button so that the test button could be pressed and
5 moved into contact with the switch structure by the application of pressure from the outside of the package.

THE DRAWINGS

Figure 1 is a front elevational view of a powered operating device in the form of a toothbrush housed in a package in accordance with this invention;

10 Figure 2 is a side elevational view of the device shown in Figure 1;

Figure 3 is a fragmental front elevational view of the toothbrush shown in Figures 1-2 illustrating the external portion of the switch structure;

Figure 4 is a rear elevational view of the test button shown in Figures 1-2;

15 Figures 5 and 6 are fragmental partial cross-sections showing the toothbrush of Figures 1-2 in different modes of test operation;

Figure 7 is a front elevational view showing the internal switch structure used in the toothbrush of Figures 1-2; and

Figure 8 is a front elevational view showing a modified form of cleaning head for a toothbrush in accordance with this invention.

20

DETAILED DESCRIPTION

Figures 1-2 illustrate an assembly 10 in accordance with this invention wherein a powered operating device 12 is provided with a test button 14 so that a potential purchaser of the device or other user may confirm the operability of the device 12. In the illustrated
25 form the device 12 is a toothbrush. It is to be understood, however, that the invention may be practiced with other types of powered operating devices. In general, such powered operating devices would include a movable section which for the toothbrush 12 is located in the cleaning head 16 having outwardly extending cleaning elements such as bristles 18. The toothbrush 12 also includes a hollow handle 20. Mounted within the handle 20 is a
30 suitable power source such as a battery 22 as shown in Figure 5. The battery operates the movable section of the cleaning head 16 through any suitable power transmitting structure which includes electrical contact pin 24. In the illustrated version of the toothbrush 12

shown in Figures 1-2 the movable section is a vibratory type of movement of the bristles. An example of such type of motion is described in U.S. Published Application 2002/0124333 all of the details of which are incorporated herein by reference thereto. Any other type of movement, however, may be used in accordance with this invention. Thus, 5 Figure 8 illustrates a cleaning head 16A which includes a disk-like movable section 26 which could, for example, be oscillated back and forth in a rotational manner by a drive mechanism, such as shown in U.S. Patent No. 5,625,916, all of the details of which are incorporated herein by reference thereto.

The power transmitting structure for operating the movable section is controlled by 10 a switch structure 28. Figure 3 illustrates the outer portion of the hollow handle 20 to have a flexible wall 30. One location of the wall 30 has an outward protrusion 32 which is at the on position of the switch structure. Another smaller outward protrusion 34 is at the off position of the switch structure. Figures 5-7 illustrate the details of the main portion of the switch structure which is a spring switch 36 of a rocker type construction. As shown in 15 Figure 7 the spring switch 36 has a pair of slits 38,38 creating a movable central portion 60 and a pair of side portions 62,62. Spring 36 also includes an outer movable free end 40. When the outer end 40 of spring 36 is pressed, the outer end 40 contacts electrical contact pin 24 to activate the power transmitting structure for moving the movable section of the powered operated device such as the movable section of the cleaning head 16. In 20 this condition central portion 60 is rocked outwardly of side portions 62. When the off location portion 40 of spring 36 is activated, the on portion 40 is moved away from and out of contact with electrical contact pin 24 thereby inactivating the power transmitting structure. Central portion 60 is rocked inwardly of side portions 62. This position is shown in Figure 6. Ordinarily, in the normal operation of toothbrush 12 the on button 32 25 would be pressed to push spring portion 40 to bend the spring 36 so that its on location portion 40 makes electrical contact with contact pin 24 and remains in contact with contact pin 24 thereby resulting in continuous operation of the movable section of toothbrush 12. The continuous operation is halted when the off button portion 34 is pressed to push portion 42 of central portion 60 back to the position shown in Figure 6. The end 40 of 30 spring 36 flexes away from and out of contact with contact pin 24 to inactivate the power transmitting structure so that the movable section no longer moves.

Advantageously the test procedure will work regardless of what portion of test

button 14 is pressed. As long as pressure is applied to any location of the outer surface 52 of test button 14, the entire rigid test button 14 will move inwardly pressing against both on and off buttons 32,34. Spring 36 is flattened to result in on portion 40 contacting pin 24. In this flattened condition of spring 36, the tendency for spring 36 to return to its off position is overcome by the inward pressing of test button 14. Spring 36, then returns to its off position shown in Figure 6 upon the removal of the pressure.

The toothbrush 12 may be packaged in any suitable manner. In the embodiment illustrated herein the package includes a generally stiff backing member 44 which could be made of cardboard, stiff plastic or any other suitable material. A transparent plastic blister 46 is mounted to backing 44 to completely enclose the toothbrush 12 yet permit the toothbrush to be visible. The backing and bubble laminate at the upper end of the package may include a cut-out 48 so that the package could be hung for display purposes. One portion of the bubble 46 has an outward offset 50 as shown in Figure 2. The outward offset 50 is located at the switch structure. Also located in this offset portion is the test button 14. Test button 14 may be made of any suitable material and may be of any suitable shape. In the illustrated embodiment test button 14 is a stiff plate or block having a generally convex outer surface 52 and a generally concave inner surface 54. A pair of activating posts 56,58 extend outwardly from inner surface 54. Activating pin 58 is longer than activating pin 56. As a result, when in the normal packaged condition activating pin 56 makes slight non-pressure contact with the on location button 32 while activating pin or post 58 makes slight non-pressure contact with the off location button 34. This condition is also illustrated in Figure 6.

When it is desired to test the operability of the toothbrush 12, pressure is applied against test or activation button 14 as shown in Figure 5. This results in the pressure being applied simultaneously to both the on and off buttons 32,34 and to the on and off position 40,42 of the switch structure which flattens the spring 36 so that contact is made between the on position 40 and electrical contact pin 24 to activate the power transmitting structure thus causing operation of the movable section. When the pressure is released, because central portion 60 at its off location 42 had also been under pressure, the spring 36 snaps back to the position shown in Figure 6 with the on position 40 out of contact with electrical contact pin 24. As a result, the device or toothbrush 12 can be momentarily operated, when in the condition of Figure 5, assuring that the device is restored to the

“off” position by the consumer simply letting go of the package. Battery life will thereby be preserved without the consumer consciously having to turn the device off.

Once the device is purchased the device is removed from the package and the test button 14 can be discarded. Thereafter the switch structure would be activated, as
5 previously discussed, by either selectively pressing the on button 32 or the off button 34. When the on button 32 is pressed the outer portion 40 of spring 36 is moved into contact with the electrical contact pin 24 and the operation of the movable section is initiated and remains continuously on. When it is desired to inactivate the operation the off button 34 is
10 pressed. This causes the central portion 60 of the spring to flex so that the on location portion 40 is moved out of contact with the electrical contact pin 24. The spring 36 remains in this off condition until the on button 32 is again pressed.

Because the on activating button 32 and the off activating button 34 are integral parts of the resilient wall 30, the buttons may be depressed inwardly from their normal position shown in Figure 2 a sufficient distance to contact the spring 36. Upon release the
15 buttons 32,34 then return to their normal position. In the meantime, however, by pressing either button 32 or 34 the contact made with the spring 36 cause the spring to rock to its appropriate on or off position.

The present invention has distinct advantages over various approaches taken in the prior art to provide test structure. The present invention is based on the recognition that
20 the primary need for such test structure is in conjunction with a prospective purchaser wishing to either see the operation of a proposed purchased device and/or to be sure that the device does, in fact, operate. As such, once the item or device is purchased there is no longer such a need for the test structure. Bearing this recognition in mind, the present invention provides a test button which is separate and distinct from the device itself. As a
25 result, it is not necessary to have the device itself incorporate its own test switch as is done in one of the prior art approaches and it is not necessary to have the on switch capable of two different types of actuating movements such as a pressing inward or a sliding as is done in other prior art approaches. Instead, the test button of the present invention could be utilized with devices such as powered toothbrushes particularly of the rocker switch
30 type devices without requiring any modification of the device itself. Instead, the modification is made in the packaging of the device wherein the separate test button is located in a package compartment that would place the test button juxtaposed both the on

switch and the off switch so that by pressing against the compartment the test button would be pressed against the on and off switch providing for only momentary actuation of the device while the test button remains pressed and assuring that the device is inactivated upon release of the pressure. Accordingly, the prospective purchaser would use the same
5 pressing motion for test purposes as would be used for both turning the device on and turning the device off. Once the device has been purchased and removed from the package the test button could be discarded since it would have achieved its intended purpose.

WHAT IS CLAIMED IS:

1. A powered operating device disposed within a package, comprising:
a movable section,
a power source,
a power transmitting structure for transmitting power from the power source to the movable section to cause the movable section to move,
a switch structure having an on position for activating the power transmitting structure, the switch structure further having an off position for inactivating the power transmitting structure, wherein the switch structure remains in a continuous operation condition until inactivated by the actuation at said off position,
a test feature that is implemented through said package and disposed for simultaneously contacting both said on position and said off position upon a user applying pressure to said test feature,
said test feature being normally located in a position that does not apply pressure to said on position, and the application of pressure against said test feature causing activation of said switch structure to cause said movable section to move to verify the operability of said powered operating device and the release of pressure against said test feature causing said switch structure to be immediately in its off condition and cease operation of said movable section after the operability has been confirmed.
2. The device of claim 1, wherein said switch structure includes a rocker spring which is selectively movable to an on condition and onto an off condition in accordance with pressure being applied against different portions of said spring, and said test feature being separate and distinct from said switch structure.
3. The device of claim 2, wherein said switch structure includes an on button and an off button selectively movable into contact with said spring, and said test button being juxtaposed both said on button and said off button.
4. The device of claim 3, wherein said power transmitting structure includes an electrical contact pin disposed in the path of movement of said on position portion of said spring.
5. The device of claim 4, wherein said test feature is in the form of a block disposed between said package and said powered operating device and having outwardly extending posts located for respectively contacting said on activating button and said off

activating button.

6. The device of claim 5, wherein said spring includes a pair of slits forming an intermediate central portion and a pair of outwardly extending portions, said central portion and said outwardly extending portions being bendable independently of each other, said spring having a movable outer end which is its on position, and a portion of said intermediate portion being the off position of said spring.

7. The device of claim 6, wherein said spring is disposed in a flat condition when pressure is applied to said test feature to apply pressure simultaneously at said on position and said off position.

8. The device of claim 7, wherein said powered operating device is a powered toothbrush.

9. The device of claim 8, said package having an outer wall which includes a flexible portion, and said block being mounted in said flexible portion.

10. The device of claim 9, wherein said toothbrush includes a cleaning head, said movable section being at least part of said cleaning head, said toothbrush also including a handle connected to said cleaning head, said handle being hollow, said power source being a battery in said hollow handle, and said switch structure being mounted at said hollow handle.

11. The device of claim 1, wherein said powered operating device is a powered toothbrush.

12. The device of claim 11, said package having an outer transparent wall which includes a flexible portion, and said test feature includes a block that is mounted in said flexible portion.

13. The device of claim 12, wherein said toothbrush includes a cleaning head, said movable section being at least part of said cleaning head, said toothbrush also including a handle connected to said cleaning head, said handle being hollow, said power source being a battery in said hollow handle, and said switch structure being mounted at said hollow handle.

14. The device of claim 1, wherein said test feature is integral with said package.

15. A powered toothbrush device disposed within a package, comprising:
a movable section,

a power source,
a power transmitting structure for transmitting power from the power source to the movable section to cause the movable section to move,
a switch having an on position for activating the power transmitting structure and an off position for inactivating the power transmitting structure, and
a test feature implemented through said package that simultaneously contacts both said on position and said off position upon a user applying pressure to said test feature for momentary operation of said powered operating device, the removal of said user-applied pressure causing said switch to assume the off position.

16. The device of claim 15, wherein said switch includes a rocker spring which is selectively movable between said on and said off conditions in accordance with pressure being applied against different portions of said spring, said test feature being separate and distinct from said switch.

17. The device of claim 16, wherein said switch includes an on button and an off button selectively movable into contact with said spring, said test feature juxtaposing both said on button and said off button.

18. The device of claim 17, wherein said test feature is in the form of a block disposed between said package and said powered operating device and having outwardly extending posts located for respectively contacting said on activating button and said off activating button.

19. The device of claim 18, said package having an outer wall which includes a flexible portion, and said block being mounted in said flexible portion.

20. The device of claim 15, further comprising a cleaning head, said movable section being at least part of said cleaning head, a hollow handle connected to said cleaning head, said power source being a battery in said hollow handle, and said switch structure being mounted at said hollow handle.

21. The device of claim 20, said package having an outer transparent wall which includes a flexible portion, and said test feature includes a block that is mounted in said flexible portion.

22. The device of claim 15, wherein said test feature is integral with said package.

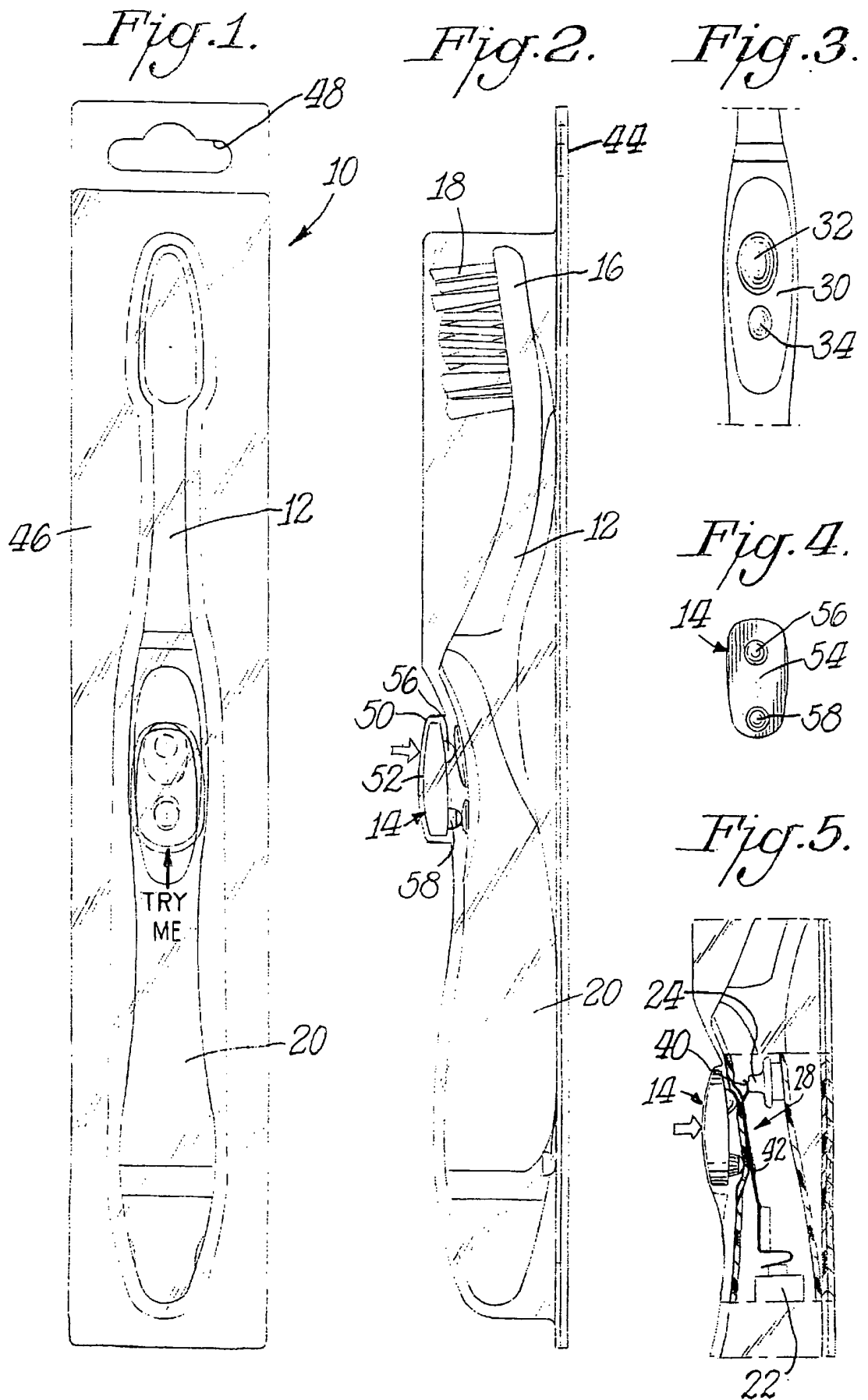

Fig. 6.

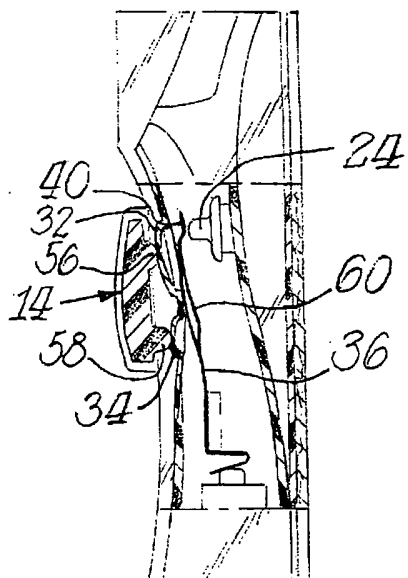

Fig. 7.

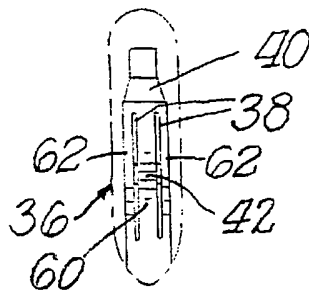
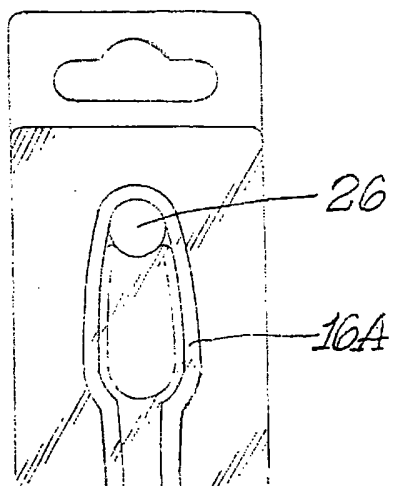

Fig. 8.



INTERNATIONAL SEARCH REPORT

International Application No
PCT/US2005/002124

A. CLASSIFICATION OF SUBJECT MATTER
IPC 7 A61C17/26 A61C17/34 A61C17/22 H01H9/02

According to International Patent Classification (IPC) or to both national classification and IPC

B. FIELDS SEARCHED

Minimum documentation searched (classification system followed by classification symbols)
IPC 7 A61C H01H

Documentation searched other than minimum documentation to the extent that such documents are included in the fields searched

Electronic data base consulted during the international search (name of data base and, where practical, search terms used)

EPO-Internal

C. DOCUMENTS CONSIDERED TO BE RELEVANT

Category °	Citation of document, with indication, where appropriate, of the relevant passages	Relevant to claim No.
X	US 2001/054561 A1 (BLAUSTEIN LAWRENCE A ET AL) 27 December 2001 (2001-12-27) the whole document	1,2, 11-16, 20-22
X	US 2003/221267 A1 (CHAN JOHN G) 4 December 2003 (2003-12-04) the whole document	1,2, 11-16, 20-22
A	US 2003/205492 A1 (FERBER ROMAN S ET AL) 6 November 2003 (2003-11-06) the whole document	1,15

Further documents are listed in the continuation of box C.

Patent family members are listed in annex.

° Special categories of cited documents :

- *A* document defining the general state of the art which is not considered to be of particular relevance
- *E* earlier document but published on or after the international filing date
- *L* document which may throw doubts on priority claim(s) or which is cited to establish the publication date of another citation or other special reason (as specified)
- *O* document referring to an oral disclosure, use, exhibition or other means
- *P* document published prior to the international filing date but later than the priority date claimed

- *T* later document published after the international filing date or priority date and not in conflict with the application but cited to understand the principle or theory underlying the invention
- *X* document of particular relevance; the claimed invention cannot be considered novel or cannot be considered to involve an inventive step when the document is taken alone
- *Y* document of particular relevance; the claimed invention cannot be considered to involve an inventive step when the document is combined with one or more other such documents, such combination being obvious to a person skilled in the art.
- *&* document member of the same patent family

Date of the actual completion of the international search

22 July 2005

Date of mailing of the international search report

29/07/2005

Name and mailing address of the ISA
European Patent Office, P.B. 5818 Patentlaan 2
NL - 2280 HV Rijswijk
Tel. (+31-70) 340-2040, Tx. 31 651 epo nl,
Fax: (+31-70) 340-3016

Authorized officer

Salvatore, C

INTERNATIONAL SEARCH REPORT

Information on patent family members

International Application No
PCT/US2005/002124

Patent document cited in search report	Publication date	Patent family member(s)	Publication date
US 2001054561	A1	27-12-2001	US 6371294 B1 16-04-2002
			US 6178579 B1 30-01-2001
			US 6189693 B1 20-02-2001
			US 6000083 A 14-12-1999
			CA 2465716 A1 06-03-2003
			CN 1496240 A 12-05-2004
			EP 1383443 A2 28-01-2004
			WO 03017861 A2 06-03-2003
			JP 2004520929 T 15-07-2004
			TW 495359 B 21-07-2002
			US 2002152564 A1 24-10-2002
			US 2004088807 A1 13-05-2004
			US 2001022277 A1 20-09-2001
			US 2002020645 A1 21-02-2002
			US 2002017474 A1 14-02-2002
			US 2002029988 A1 14-03-2002
			AU 2296401 A 17-04-2001
			CA 2364232 A1 22-03-2001
			CN 1423545 A 11-06-2003
			EP 1143875 A2 17-10-2001
			JP 2004507273 T 11-03-2004
			MX PA01006566 A 14-07-2003
			TR 200101408 T1 21-08-2002
			TW 474803 B 01-02-2002
			WO 0119281 A2 22-03-2001
			US 2002078514 A1 27-06-2002
			US 2004074026 A1 22-04-2004
			US 2001004781 A1 28-06-2001
			US 2002032941 A1 21-03-2002
			AU 748925 B2 13-06-2002
			AU 4882999 A 06-04-2000
			BR 9908667 A 10-10-2000
			CA 2282957 A1 30-03-2000
			CN 1491622 A 28-04-2004
			CN 1515233 A 28-07-2004
			CN 1252248 A ,C 10-05-2000
DE 29924223 U1 06-06-2002			
EP 0990424 A1 05-04-2000			
JP 3566150 B2 15-09-2004			
JP 2000210307 A 02-08-2000			
JP 2004223276 A 12-08-2004			
KR 2000023525 A 25-04-2000			
NZ 337972 A 25-05-2001			
RU 2234287 C2 20-08-2004			
SG 79283 A1 20-03-2001			
TR 9902394 A2 21-04-2000			
TW 490297 B 11-06-2002			
<hr/>			
US 2003221267	A1	04-12-2003	AU 2003232429 A1 19-12-2003
			EP 1509165 A1 02-03-2005
			WO 03101338 A1 11-12-2003
			US 2003221983 A1 04-12-2003
<hr/>			
US 2003205492	A1	06-11-2003	NONE
<hr/>			