



INTERNATIONAL APPLICATION PUBLISHED UNDER THE PATENT COOPERATION TREATY (PCT)

<p>(51) International Patent Classification ⁷ : B26F 1/20, B26D 11/00</p>	<p>A1</p>	<p>(11) International Publication Number: WO 00/06351 (43) International Publication Date: 10 February 2000 (10.02.00)</p>
<p>(21) International Application Number: PCT/IT99/00230 (22) International Filing Date: 21 July 1999 (21.07.99) (30) Priority Data: FI98U000081 27 July 1998 (27.07.98) IT (71) Applicant (for all designated States except US): FABIO PERINI S.P.A. [IT/IT]; Via per Mugnano, I-55100 Lucca (IT). (72) Inventor; and (75) Inventor/Applicant (for US only): BIAGIOTTI, Guglielmo [IT/IT]; Via di Vorno, 105, Capannori, I-55060 Lucca (IT). (74) Agents: MANNUCCI, Gianfranco et al.; Via della Scala, 4, I-50123 Firenze (IT).</p>		<p>(81) Designated States: AE, AL, AM, AT, AU, AZ, BA, BB, BG, BR, BY, CA, CH, CN, CU, CZ, DE, DK, EE, ES, FI, GB, GD, GE, GH, GM, HR, HU, ID, IL, IN, IS, JP, KE, KG, KP, KR, KZ, LC, LK, LR, LS, LT, LU, LV, MD, MG, MK, MN, MW, MX, NO, NZ, PL, PT, RO, RU, SD, SE, SG, SI, SK, SL, TJ, TM, TR, TT, UA, UG, US, UZ, VN, YU, ZA, ZW, ARIPO patent (GH, GM, KE, LS, MW, SD, SL, SZ, UG, ZW), Eurasian patent (AM, AZ, BY, KG, KZ, MD, RU, TJ, TM), European patent (AT, BE, CH, CY, DE, DK, ES, FI, FR, GB, GR, IE, IT, LU, MC, NL, PT, SE), OAPI patent (BF, BJ, CF, CG, CI, CM, GA, GN, GW, ML, MR, NE, SN, TD, TG).</p> <p>Published With international search report.</p>

(54) Title: PERFORATOR FOR WEBLIKE MATERIALS WITH MEANS FOR MODIFYING THE INTERVAL BETWEEN CONSECUTIVE LINES OF PERFORATIONS

(57) Abstract

The perforating unit comprises: a support (23) with at least two fixed counterblades (25A, 25B); a first roller (27) revolving about its own axis and carrying a first series of rotary blades (29) acting in combination with a first (25A) one of said fixed counterblades; a second roller (31) revolving about its own axis and carrying a second series of rotary blades (33) acting in combination with the second (25B) one of said fixed counterblades. The blades of the first series are arranged at a different pitch from the blades of the second series of blades.

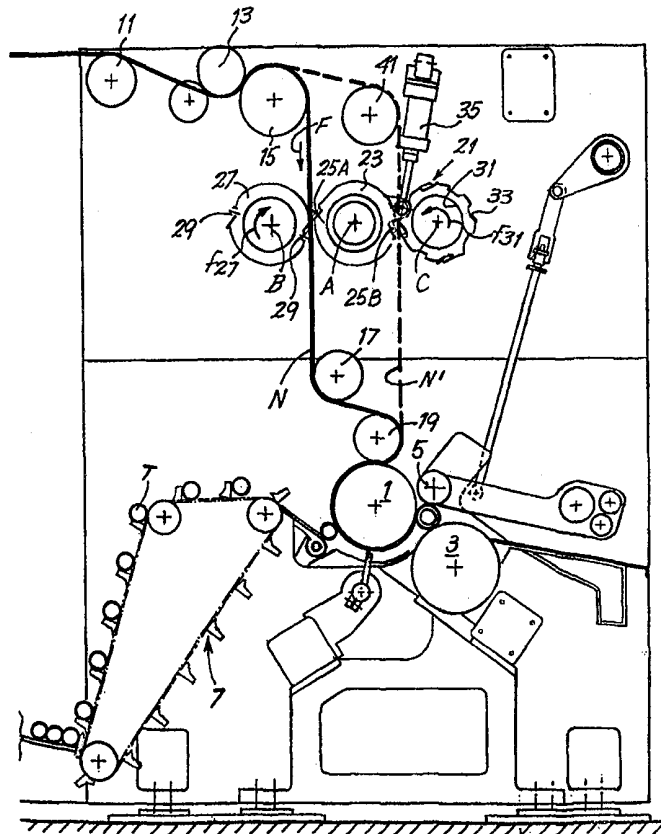

FOR THE PURPOSES OF INFORMATION ONLY

Codes used to identify States party to the PCT on the front pages of pamphlets publishing international applications under the PCT.

AL	Albania	ES	Spain	LS	Lesotho	SI	Slovenia
AM	Armenia	FI	Finland	LT	Lithuania	SK	Slovakia
AT	Austria	FR	France	LU	Luxembourg	SN	Senegal
AU	Australia	GA	Gabon	LV	Latvia	SZ	Swaziland
AZ	Azerbaijan	GB	United Kingdom	MC	Monaco	TD	Chad
BA	Bosnia and Herzegovina	GE	Georgia	MD	Republic of Moldova	TG	Togo
BB	Barbados	GH	Ghana	MG	Madagascar	TJ	Tajikistan
BE	Belgium	GN	Guinea	MK	The former Yugoslav Republic of Macedonia	TM	Turkmenistan
BF	Burkina Faso	GR	Greece			TR	Turkey
BG	Bulgaria	HU	Hungary	ML	Mali	TT	Trinidad and Tobago
BJ	Benin	IE	Ireland	MN	Mongolia	UA	Ukraine
BR	Brazil	IL	Israel	MR	Mauritania	UG	Uganda
BY	Belarus	IS	Iceland	MW	Malawi	US	United States of America
CA	Canada	IT	Italy	MX	Mexico	UZ	Uzbekistan
CF	Central African Republic	JP	Japan	NE	Niger	VN	Viet Nam
CG	Congo	KE	Kenya	NL	Netherlands	YU	Yugoslavia
CH	Switzerland	KG	Kyrgyzstan	NO	Norway	ZW	Zimbabwe
CI	Côte d'Ivoire	KP	Democratic People's Republic of Korea	NZ	New Zealand		
CM	Cameroon			PL	Poland		
CN	China	KR	Republic of Korea	PT	Portugal		
CU	Cuba	KZ	Kazakstan	RO	Romania		
CZ	Czech Republic	LC	Saint Lucia	RU	Russian Federation		
DE	Germany	LI	Liechtenstein	SD	Sudan		
DK	Denmark	LK	Sri Lanka	SE	Sweden		
EE	Estonia	LR	Liberia	SG	Singapore		

PERFORATOR FOR WEBLIKE MATERIALS WITH MEANS FOR
MODIFYING THE INTERVAL BETWEEN CONSECUTIVE LINES OF
PERFORATIONS

5

DESCRIPTION

The present invention relates to a perforating unit of the type commonly used for making transverse lines of perforations at predetermined intervals on a weblike material, for example a web or sheet of tissue paper for the production of toilet paper, kitchen towels or the like.

A device of this kind is described in US-A-5,284,304. The lines of perforations are arranged at intervals from each other defined by the type of use to which the material perforated in this way is put. For example, when this material is used for the production of rolls of toilet paper, the distance between consecutive lines of perforations is relatively small and corresponds to the length of the single sheets of toilet paper that can be torn off along the lines of perforations when the weblike material has been converted into rolls of toilet paper. In the production of rolls of kitchen towels, the interval between the lines of perforations is greater, approximately twice the interval between the lines of perforations of toilet paper. Typically, the interval between the lines of perforations is 100-140 mm for toilet paper and 220-280 for kitchen towels. Even larger distances, e.g. 380-400 mm are used for products for industrial use. Lengths of 1800-2000 mm are used for the production of rolls for medical use, e.g. for covering examination beds and folding beds.

At the present time, the perforating units used for these purposes comprise a support equipped with a basically fixed counterblade acting in combination with a certain number of rotary blades carried by a roller revolving about its own axis. The interval between the lines of perforations can be modified within certain limits (approximately 20%) by varying the speed of rotation of the bladed roller and thereby introducing slippage between the rotary blades and the weblike material passing between them and the fixed counterblade. To maintain perpendicularity between the feed direction of the

weblike material and the line of perforations when this speed variation is introduced, it becomes necessary to vary the inclination of the support of the fixed counterblade and of the revolving roller relative to the feed direction of the weblike material.

5 The variations to the intervals between adjacent lines of perforations that can be produced in this way are not enough to convert from the interval required for toilet paper to that required for kitchen towels. In these cases it is also necessary to modify the number of blades mounted on the revolving roller. For example, if six blades are used in making toilet paper, to
10 switch to the making of kitchen towels three of the six blades mounted on the rotary roller must be removed. Subsequent return to making toilet paper necessarily requires replacement of all blades, as the three blades that have temporarily been producing the kitchen towels will have become more worn than the three blades that were removed when switching from the production
15 of toilet paper to kitchen towels.

 The removal of some of the blades and/or the replacement of all of the blades when switching from one type of product to the other takes up a great deal of time and therefore requires long machine down times with consequent loss of output, besides high costs caused by the impossibility of
20 using entirely all the blades.

 The object of the present invention is to provide a perforating device that overcomes this problem and makes it possible to switch quickly from one type of production to another characterized by different intervals between adjacent lines of perforations, thereby reducing unused time to a
25 minimum. Another object of the present innovation is to provide a device that does not require the blades to be replaced until actually completely worn down.

 These and other objects and advantages, which will be clear to those skilled in the art on reading the text that follows, are achieved basically
30 with a perforating unit comprising:

- a support with at least two fixed counterblades;
- a first roller revolving about its own axis and carrying a first series of

rotary blades acting in combination with a first one of said fixed counterblades;

5 a second roller revolving about its axis and carrying a second series of rotary blades acting in combination with the second one of said fixed counterblades, the blades of said first series being arranged at a different pitch from the blades of the second series of blades.

10 With this device, in order to switch from one production to the other, the path of the weblike material need simply be modified. In one case it will pass between the first revolving roller and the fixed support, and in the other case it will pass between the second revolving roller and the same fixed support. Depending on the path of the weblike material, one or other of the two counterblades carried by the intermediate support will act in combination with one or other of the two series of blades carried by the two revolving rollers.

15 The different circumferential pitch between the two series of blades can be obtained with two rotary rollers equipped with different numbers of blades, for example twice as many blades on one roller as on the other. Alternatively, the two series of blades could have the same number of blades but they could be arranged on revolving rollers of different diameters. Also possible are combinations of these two solutions, i.e. the use of revolving rollers of different diameters and carrying different numbers of blades.

In one possible embodiment, one of the two revolving rollers comprises twice as many blades as the other, for example four blades on one roller and two on the other, or three blades on one roller and six on the other.

25 Advantageously, the support carrying the two fixed counterblades may be connected to members that modify its angular position in order to bring one or other of the fixed counterblades alternately into operation, e.g. by a slight pivoting about an axis.

30 As in the prior art, so in the device according to the invention the two revolving rollers and the support may have a variable inclination that can be adjusted to obtain a further possibility of variation (within narrow limits) of the interval between consecutive lines of perforations produced on the

weblike material.

Other advantageous characteristics of the device according to the invention will be explained below and are indicated in the appended claims.

The single figure attached shows a schematic side view of a
5 rewinding machine comprising a perforating unit according to the invention.

In the attached figure the rewinding machine has a set of three winding rollers marked 1, 3 and 5, upstream of which is a feed system 7 for tubular cores T on which a weblike material is wound. The structure of the rewinding machine is known per se and will not be described in greater detail
10 below. The perforating unit which will be described later may typically be connected to this type of rewinding machine, but there is no reason why it should not also be adopted in other types of machine where similar problems and requirements arise.

The weblike material N is fed toward the winding zone defined by
15 the set of three rollers 1, 3 and 5 along a path defined by cylinders 11, 13, 15, 17 and 19. Between the cylinders 15 and 17 is a perforating unit 21 comprising a central support 23 with axis A carrying a pair of counterblades 25A, 25B in symmetrically opposite positions on the support 23.

To the left (when viewing the figure) of the support 23 is a first
20 revolving roller 27 rotating in the direction of the arrow f27 about an axis B. A first series of two rotary blades 29 is fixed in diametrically opposite positions to the revolving roller 27. The blades 29 act in combination with the counterblade 25A of the fixed support 23.

To the right of the support 23 (when viewing the figure) is a second
25 revolving roller 31 rotating about an axis C in the direction of the arrow f31 and carrying a second series of four rotary blades 33 distributed uniformly around the circumference of the roller 31. The rotary blades 33 act in combination with the fixed counterblade 25B mounted on the support 23. The roller 31 also possesses another series of four seats for optional application of
30 four more rotary blades.

The support 23 can pivot about its axis A, being controlled in this by a cylinder-and-piston actuator 35. By pivoting the support 23 appropriately,

- 5 -

it is possible to bring into operation either the fixed counterblade 25A or the fixed counterblade 25B.

As known per se, the blades 29 and 33, or the counterblades 25A and 25B, are toothed so as to produce lines of perforations on the weblike material N. Again as known per se, the rotary blades 29 and 33 may run helically about their respective revolving rollers 27 and 31 and these latter, like the support 23, are in this case inclined relative to the normal to the forward direction F of the weblike material N. Perforation therefore takes place progressively point by point and the result is lines or perforations that are exactly perpendicular to the sides of the weblike material N and therefore to the forward direction of said material. It is also possible, as known to those skilled in the art, to modify the angular velocity of the roller 27 or of the roller 31 and to modify appropriately the inclination of the support 23 and of the working roller in order to vary within certain limits the interval between the lines of perforations by introducing a relative speed between the weblike material N advancing in the direction of the arrow F and the rotary blades 29 or 33. When altering this inclination, care is taken to keep the axes of the rollers 27, 31 and support 23 parallel with each other.

In the figure, a solid line shows the weblike material N passing between the rotary blades 29 and the fixed counterblade 25A. The large angular distance between the blades 29 enables lines of perforations to be produced on the weblike material at relatively long distances, e.g. for the production of kitchen towels.

The figure also shows, in a broken line, an alternative path for a weblike material N' which is guided about an auxiliary cylinder 41 so that its path runs between the counterblade 25B and revolving roller 31. In this condition the relative angular proximity of the rotary blades 33 enables a weblike material to be produced with closer lines of perforations, e.g. for the production of toilet paper.

As mentioned earlier, the different distance between the blades of the first series of blades 29 compared to the distance between the blades of the second series of blades 33 can be achieved by using revolving rollers 27,

31 of different diameters.

- 7 -
CLAIMS

1. A perforating unit for a weblike material comprising:
 - a support with at least two fixed counterblades;
 - a first roller revolving about its own axis and carrying a first series of rotary blades acting in combination with a first one of said fixed counterblades;
- 5
10
15
20
25
2. Perforating unit as claimed in claim 1, in which said first series of blades comprises a different number of blades than the number of blades of the second series of blades.
3. Perforating unit as claimed in claim 1 or 2, in which said first revolving roller and said second revolving roller have different diameters.
4. Perforating unit as claimed in one or more of the previous claims, in which said first series of rotary blades comprises twice as many blades as the second series.
5. Perforating unit as claimed in one or more of the previous claims, in which said support can adopt at least two different angular positions in order to bring one or other of said fixed counterblades alternately into operation.
6. Perforating unit as claimed in one or more of the previous claims, in which said fixed counterblades and said rotary blades are inclined relative to the transverse direction of the weblike material to be perforated and said rotary blades are helical in form.
7. Perforating unit as claimed in claim 6, in which said fixed counterblades and said rotary blades have a variable inclination with respect to the transverse direction of the weblike material to be perforated.

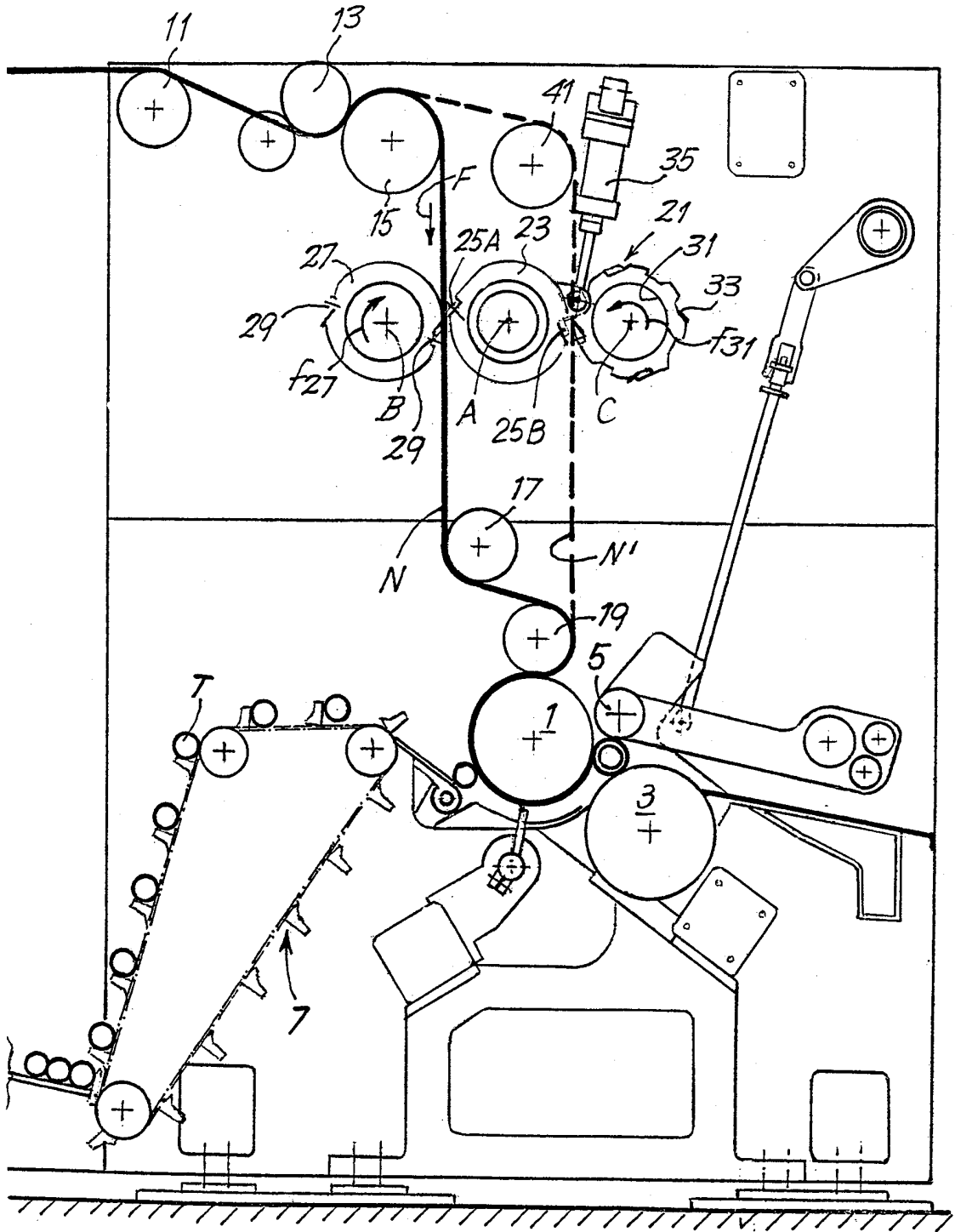

INTERNATIONAL SEARCH REPORT

International Application No
PCT/IT 99/0230

A. CLASSIFICATION OF SUBJECT MATTER
IPC 7 B26F1/20 B26D11/00

According to International Patent Classification (IPC) or to both national classification and IPC

B. FIELDS SEARCHED

Minimum documentation searched (classification system followed by classification symbols)
IPC 7 B26F B26D

Documentation searched other than minimum documentation to the extent that such documents are included in the fields searched

Electronic data base consulted during the international search (name of data base and, where practical, search terms used)

C. DOCUMENTS CONSIDERED TO BE RELEVANT

Category °	Citation of document, with indication, where appropriate, of the relevant passages	Relevant to claim No.
Y	WO 90 02639 A (DOVERSTAR MACHINERY LIMITED) 22 March 1990 (1990-03-22) page 2, paragraph 2 - paragraph 5 page 6, paragraph 4 ----	1-3
Y	FR 2 204 540 A (SCHMERMUND ALFRED) 24 May 1974 (1974-05-24) page 2, line 37 - line 38; figure 1 ----	1-3
A	EP 0 783 940 A (SASIB SPA) 16 July 1997 (1997-07-16) column 7, line 15 - line 20; figures ----	5
A	DE 19 57 212 A (BOBST AG) 25 June 1970 (1970-06-25) page 10, paragraph 2 -page 12, paragraph 1 ----- -/--	6,7

Further documents are listed in the continuation of box C.

Patent family members are listed in annex.

° Special categories of cited documents :

- "A" document defining the general state of the art which is not considered to be of particular relevance
- "E" earlier document but published on or after the international filing date
- "L" document which may throw doubts on priority claim(s) or which is cited to establish the publication date of another citation or other special reason (as specified)
- "O" document referring to an oral disclosure, use, exhibition or other means
- "P" document published prior to the international filing date but later than the priority date claimed

- "T" later document published after the international filing date or priority date and not in conflict with the application but cited to understand the principle or theory underlying the invention
- "X" document of particular relevance; the claimed invention cannot be considered novel or cannot be considered to involve an inventive step when the document is taken alone
- "Y" document of particular relevance; the claimed invention cannot be considered to involve an inventive step when the document is combined with one or more other such documents, such combination being obvious to a person skilled in the art.
- "&" document member of the same patent family

Date of the actual completion of the international search

15 October 1999

Date of mailing of the international search report

22/10/1999

Name and mailing address of the ISA
European Patent Office, P.B. 5818 Patentlaan 2
NL - 2280 HV Rijswijk
Tel. (+31-70) 340-2040, Tx. 31 651 epo nl,
Fax: (+31-70) 340-3016

Authorized officer

Vaglianti, G

INTERNATIONAL SEARCH REPORT

International Application No

PCT/IT 99/00230

C.(Continuation) DOCUMENTS CONSIDERED TO BE RELEVANT		
Category °	Citation of document, with indication, where appropriate, of the relevant passages	Relevant to claim No.
A	DE 36 13 859 A (GORTER CORNELIS) 29 October 1987 (1987-10-29) column 8, line 10 - line 20 -----	1

INTERNATIONAL SEARCH REPORT

Information on patent family members

International Application No

PCT/IT 79/00230

Patent document cited in search report	A	Publication date	Patent family member(s)	Publication date
WO 9002639	A	22-03-1990	NONE	
FR 2204540	A	24-05-1974	GB 1440927 A BE 806333 A DD 106978 A DE 2350580 A JP 49076696 A US 3871257 A	30-06-1976 15-02-1974 12-07-1974 09-05-1974 24-07-1974 18-03-1975
EP 0783940	A	16-07-1997	IT GE960004 A	10-07-1997
DE 1957212	A	25-06-1970	BE 741917 A CH 513701 A ES 373673 A FR 2025071 A GB 1228099 A JP 49026550 B SE 352283 B US 3552251 A	04-05-1970 15-10-1971 01-02-1972 04-09-1970 15-04-1971 10-07-1974 27-12-1972 05-01-1971
DE 3613859	A	29-10-1987	NONE	