

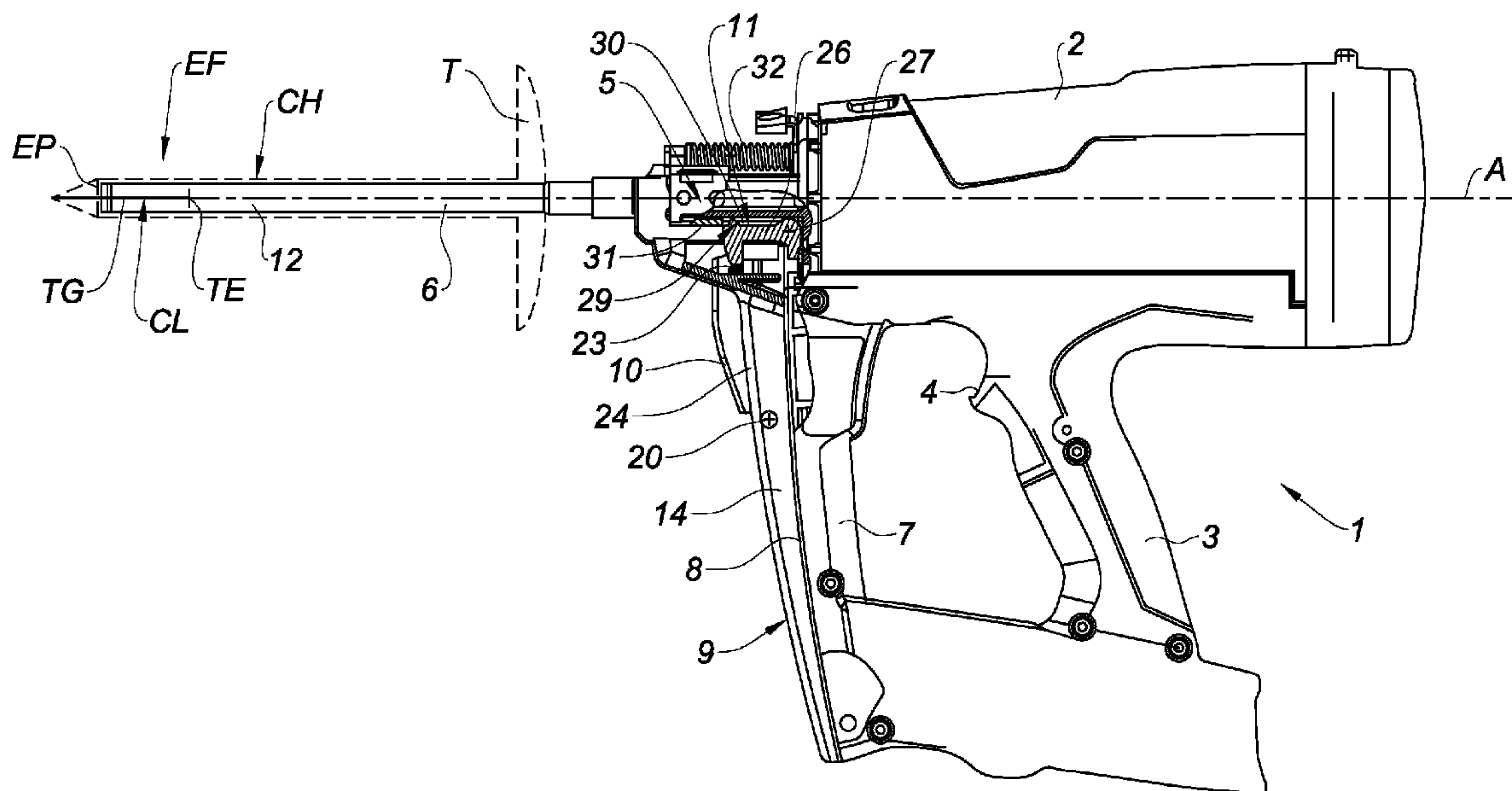

(86) Date de dépôt PCT/PCT Filing Date: 2013/07/25  
 (87) Date publication PCT/PCT Publication Date: 2014/01/30  
 (45) Date de délivrance/Issue Date: 2016/10/25  
 (85) Entrée phase nationale/National Entry: 2014/12/02  
 (86) N° demande PCT/PCT Application No.: US 2013/052102  
 (87) N° publication PCT/PCT Publication No.: 2014/018778  
 (30) Priorité/Priority: 2012/07/25 (FR1257198)

(51) Cl.Int./Int.Cl. *B25C 1/18* (2006.01),  
*B25C 1/14* (2006.01)  
 (72) Inventeurs/Inventors:  
HERELIER, PATRICK, FR;  
ROUSSON, LUDOVIC, FR  
 (73) Propriétaire/Owner:  
ILLINOIS TOOL WORKS INC., US  
 (74) Agent: FINLAYSON & SINGLEHURST

(54) Titre : OUTIL DE FIXATION A TIR INDIRECT MUNI DE SUPPORT DE GACHETTE ANTI-TIR  
 (54) Title: INDIRECT FIRING FASTENING TOOL WITH ANTI-FIRING TRIGGER SUPPORT



(57) Abrégé/Abstract:

- An indirect firing fastening tool with an anti- firing trigger support. - The tool comprises, in one case (2), an axially movable equipment (5) with a tip guide (6) projecting from the case to drive a fastening member into a support material, a reception housing (8) for a fastener charger and anti-firing safety means (11) to prevent the recoil of the tip guide, Advantageously, an anti-firing trigger (10) support (9) is mounted on said reception housing to convert the tool into a mono-firing tool, the trigger (10) being arranged to cooperate with the anti-firing safety means (11) so as to remove them and authorize firing.

(12) INTERNATIONAL APPLICATION PUBLISHED UNDER THE PATENT COOPERATION TREATY (PCT)

(19) World Intellectual Property  
Organization  
International Bureau(10) International Publication Number  
**WO 2014/018778 A3**(43) International Publication Date  
30 January 2014 (30.01.2014)(51) International Patent Classification:  
B25C 1/18 (2006.01)(21) International Application Number:  
PCT/US2013/052102(22) International Filing Date:  
25 July 2013 (25.07.2013)

(25) Filing Language: English

(26) Publication Language: English

(30) Priority Data:  
1257198 25 July 2012 (25.07.2012) FR(71) Applicant: ILLINOIS TOOL WORKS INC. [US/US];  
155 Harlem Avenue, Glenview, Illinois 60025 (US).(72) Inventors: HERELIER, Patrick; 7 rue du Vigneau, F-  
07300 Saint Jean DeMuzols (FR). ROUSSON, Ludovic;  
Quartier La Garenne, F-07210 Saint-Lager-Bressac (FR).(74) Agent: HAUPTMAN, Benjamin J.; LOWE HAUPTMAN  
HAM & BERNER, LLP, 2318 Mill Road, Suite 1400, Al-  
exandria, Virginia 22314 (US).(81) Designated States (unless otherwise indicated, for every  
kind of national protection available): AE, AG, AL, AM,  
AO, AT, AU, AZ, BA, BB, BG, BH, BN, BR, BW, BY,  
BZ, CA, CH, CL, CN, CO, CR, CU, CZ, DE, DK, DM,DO, DZ, EC, EE, EG, ES, FI, GB, GD, GE, GH, GM, GT,  
HN, HR, HU, ID, IL, IN, IS, JP, KE, KG, KN, KP, KR,  
KZ, LA, LC, LK, LR, LS, LT, LU, LY, MA, MD, ME,  
MG, MK, MN, MW, MX, MY, MZ, NA, NG, NI, NO, NZ,  
OM, PA, PE, PG, PH, PL, PT, QA, RO, RS, RU, RW, SC,  
SD, SE, SG, SK, SL, SM, ST, SV, SY, TH, TJ, TM, TN,  
TR, TT, TZ, UA, UG, US, UZ, VC, VN, ZA, ZM, ZW.(84) Designated States (unless otherwise indicated, for every  
kind of regional protection available): ARIPO (BW, GH,  
GM, KE, LR, LS, MW, MZ, NA, RW, SD, SL, SZ, TZ,  
UG, ZM, ZW), Eurasian (AM, AZ, BY, KG, KZ, RU, TJ,  
TM), European (AL, AT, BE, BG, CH, CY, CZ, DE, DK,  
EE, ES, FI, FR, GB, GR, HR, HU, IE, IS, IT, LT, LU, LV,  
MC, MK, MT, NL, NO, PL, PT, RO, RS, SE, SI, SK, SM,  
TR), OAPI (BF, BJ, CF, CG, CI, CM, GA, GN, GQ, GW,  
KM, ML, MR, NE, SN, TD, TG).

Published:

- with international search report (Art. 21(3))
- before the expiration of the time limit for amending the  
claims and to be republished in the event of receipt of  
amendments (Rule 48.2(h))

(88) Date of publication of the international search report:  
7 August 2014

(54) Title: INDIRECT FIRING FASTENING TOOL WITH ANTI-FIRING TRIGGER SUPPORT

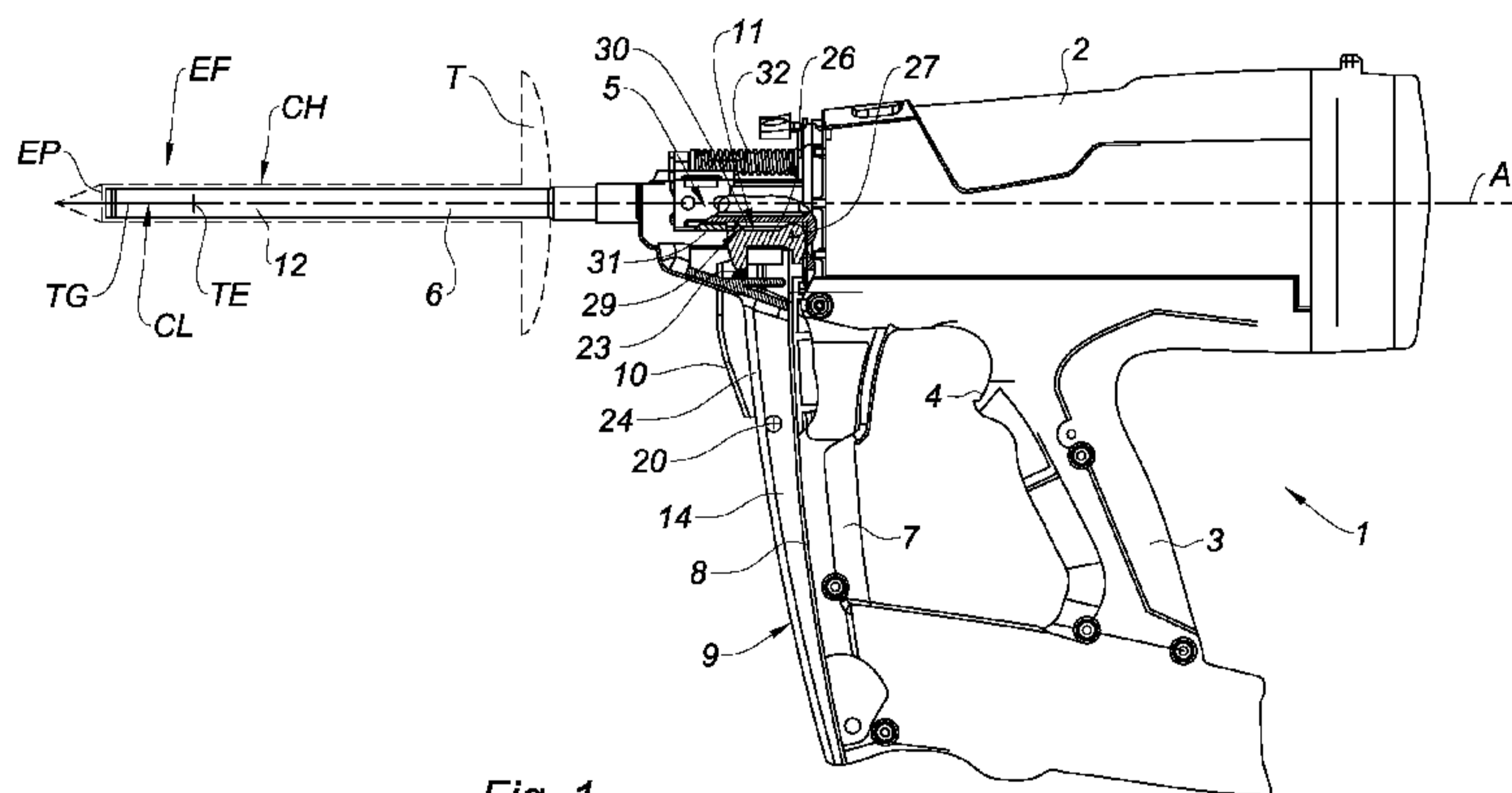

Fig. 1

(57) Abstract: - An indirect firing fastening tool with an anti- firing trigger support. - The tool comprises, in one case (2), an axially movable equipment (5) with a tip guide (6) projecting from the case to drive a fastening member into a support material, a reception housing (8) for a fastener charger and anti-firing safety means (11) to prevent the recoil of the tip guide, Advantageously, an anti-firing trigger (10) support (9) is mounted on said reception housing to convert the tool into a mono-firing tool, the trigger (10) being arranged to cooperate with the anti-firing safety means (11) so as to remove them and authorize firing.

Indirect firing fastening tool with anti-firing  
trigger support

The present invention relates to an indirect  
5 firing fastening tool through, for example, a powder  
charge or a gas cartridge.

Such fastening tools (designated by nailing  
machines) comprise, in one case, an axially movable  
equipment with a tip guide projecting from the case to  
10 drive, through the charge, a fastening member  
associated with the equipment into a support material.  
In order to be able to perform successive firings, a  
fastener charger or store is arranged in a case  
reception housing and opens into the movable equipment  
15 to drive successively the fastening members into the  
latter through a pusher.

Furthermore, as it is known, these tools are  
provided with numerous safety devices. In the present  
case, to avoid operating unnecessarily "off-load" with  
20 the fastening tool, anti-firing safety means are  
provided so that, when a few fastening members only  
are staying in the charger, the user is advised and  
replaces the almost empty charger by a full charger.  
To do so, a locking pivoting lever is connected to the  
25 case and engages into a yoke part of the tip guide  
movable equipment by axially immobilizing said  
equipment, when the pusher of the charger, with the  
successive firings, contacts the lever to move it in  
the tip guide equipment yoke. Firing is thus  
30 prevented.

Furthermore, with these usual tools, the tip  
guide of which has a normal length, it is not  
practically possible to push the tip guide either with

the finger, due to the force of the return spring of the guide in a rest position, or even with the whole hand or a jaw tool like pliers, due to the fact that the tip guide is only projecting a little from the barrel of the equipment of the device.

The problem which is at the base of the invention of the present application does not relate to a usual fastening tool, but to a fastening tool with a quite long tip guide for fastening fasteners like those being used to fasten thick insulation panels that those tip guides must cross. With such tools, an operator could easily grasp the tip guide with the hand or with pliers. The problem of the invention is to prevent, in spite of such characteristic, that an operator cannot push the tip guide towards the tool rear part without having unlocked positively an anti-firing safety.

Thus, the invention relates to an indirect firing fastening tool comprising, in one case, an axially movable equipment with a tip guide projecting from the case to drive a fastening member into a support material, a reception housing for a fastener charger and anti-firing safety means to prevent the recoil of the movable equipment and thus of the tip guide.

According to the invention, the tool is remarkable by the fact that an anti-firing trigger support is mounted on said reception housing to convert the tool into a mono-firing tool, the trigger being arranged to cooperate with the anti-firing safety means so as to remove them and authorize firing.

In particular, when there is an absence of cooperation between the trigger and the anti-firing safety means, the latter are removed from the equipment and authorize firing.

5           Thus, when the support trigger is in a rest position, the operator, even if he grasps the tip guide, cannot move it backwards up to release firing thanks to the action of the trigger on the pivoting lever of the safety means locking the displacement of  
10 the movable equipment. Only a voluntary action of the operator on the support trigger allows the lever of said tip guide movable equipment yoke to be removed and thus the latter to be released.

The trigger support so inserted as a  
15 substitution of the charger serves consequently as a control for the anti-firing safety, which is particularly interesting in the case of a long tip guide tool. The operator, by holding the tool with one hand and pushing on the trigger with the other hand,  
20 cannot grasp the long tip guide. Only the contact of the latter with the support material by overcoming the usual bearing safety device then allows firing to be released.

Moreover, a usual charger tool is  
25 advantageously used and also the safety thereof relative to the presence of fastening members to adapt it to a mono-firing tool by a simple substitution of the charger, using the safety with the trigger support arrangement.

30           Advantageously, said trigger is pivotally mounted around an axis related to the support and projects from the latter through a slot arranged in the support.

Preferably, said trigger is brought back spontaneously in a rest position through an elastic element provided between the support and the trigger, thereby locking the recoil of the tip guide movable equipment through the safety means.

In particular, said trigger presents a bearing side acting, when the trigger occupies the rest position, on the safety means so as to prevent the recoil of the equipment and being removed from the safety means when the trigger occupies the active position by a voluntary action on the latter.

According to an embodiment, the support is shown under the form of a cover being adapted to the case reception housing and having fasteners being identical to these of the charger, to cooperate with the case. The trigger support may be made of a plastic material which could be reinforced and it is obtained by molding or machining.

The invention also relates to the use of a tool with multiple firings comprising, in one case, a reception housing for a fastener charger and the reception means for a tip guide. Advantageously, to convert said multi-firing tool into a mono-firing tool, a tip guide of a big length is mounted on the tool and anti-firing safety means are acted on to remove them and authorize the recoil of the tip guide.

For example, the operation of the anti-firing safety means is performed through a trigger associated with a support mounted on the case reception housing.

4a

In a broad aspect, the invention provides an indirect firing fastening tool comprising, in one case, an axially movable equipment with a tip guide projecting from the case to drive a fastening member into a support material, a reception housing for a fastener charger and anti-firing safety means to prevent the recoil of the tip guide. An anti-firing trigger support is mounted on the reception housing to convert the tool into a mono-firing tool. The trigger is arranged to cooperate with the anti-firing safety means so as to remove the anti-firing safety means and authorize firing.

In a further aspect, the invention comprehends a utilization of a multi-firing tool comprising, in one case, a reception housing for a fastener charger and a reception means for a tip guide. To convert the multi-firing tool into a mono-firing tool, the tip guide is mounted on the tool, and anti-firing safety means are acted on to remove the anti-firing safety means and authorize recoil of the tip guide.

The invention will be better understood with the help of the following description of an indirect firing fastening tool comprising a trigger support

according to the invention, referring to the accompanying drawing, wherein:

5 - Fig. 1 is a partial longitudinal sectional view of a fastening tool for a fastening member or fastener, with a trigger support according to the invention, in a position of the trigger preventing firing;

- Fig. 2 is a rear perspective view of the trigger support;

10 - Fig. 3 is a partial enlarged view of said tool of Fig. 1, in particular of the trigger support received in a tool housing and showing the trigger in the position preventing firing; and

15 - Fig. 4 is a view similar to Fig. 3, showing the trigger in the position authorizing firing.

The fastening or fixing tool 1 shown herein comprises, in a case 2 extended by a grip 3 with an operating trigger 4 for releasing firing, an axially  
20 movable equipment 5 according to an axis A provided with a tip guide 6 with which a fastening member EF cooperates, being intended to be fastened into a support material and to which it will be referred subsequently.

25 Inside the movable equipment 5, there are, on a usual way not visible on the Figs., a propulsion piston housed in a cylinder of the equipment to drive by sliding in the tip guide the fastening member into the support material, and a source of power such as a  
30 powder charge or a gas cartridge to propel the piston.

The fastening tool 1 also comprises, in the front of the latter, ahead the grip 3, a bearing part 7 connected to the housing and forming a housing

or a reception location 8 for a fastener charger when the tool is in a configuration with repetitive multi-firings.

5 Instead of the charger, the tool comprises here, according to the invention, as shown on Figs. 1 and 2, a support 9 of an anti-firing trigger 10 to convert the multi-firing tool (with a charger) into a mono-firing tool (without any charger, with the trigger support).

10 To do so, the support 9 is adapted to the housing 8 by fastening on the bearing part 7 and, advantageously, the trigger 10 of the support is arranged to act on anti-firing safety means 11 connected to the tool and provided to lock and prevent  
15 the recoil of the movable equipment 5 and thus of the tip guide 6 (as previously recalled, initially such means advise the operator about the exhaustion of the fastening members contained within the charger).

20 According to the invention, the anti-firing safety means 11 are controlled by the trigger 10 of the support 9. In a first inactive rest position being illustrated on Figs. 1 and 3, the trigger 10 cooperates with the safety means 11 preventing the recoil of the equipment 5. And, in a second active  
25 position illustrated on Fig. 4, the trigger 10, further to a voluntary manual action on the latter, releases the anti-firing safety means 11 which are removed from the equipment and allow the latter to slide, the firing being then able to be released  
30 (Fig. 4).

For the reasons above mentioned, such a conversion of the tool into a mono-firing fastening tool 1 is particularly interesting when the member to

be fastened EF is long and that the length of the tip guide projecting from the case is then necessarily important to receive such fastening member. Indeed, it is convenient then to avoid the firing triggering by grasping directly the tip guide to move it backwards.

In this example, the fastening member EF is composed of a nail CL housed in the axial passage 12 of the tip guide 6 and of a long dowel CH mounted around the tip guide and intended to be arranged through a thick insulator to fix it to the support material by the nail. The dowel CH and the nail CL are schematically represented in a thick dashed line on Fig. 1. It is seen that the dowel extends on the tip guide with its head T (or collar) near the nose of the case 2 of the tool, whereas the stem TG of the nail aims at crossing axially the dowel to be driven, when firing is validated, into the support material, the head TE of the nail coming in contact with an internal shoulder EP of the dowel, thereby pushing the latter against the material.

The support 9 represented on Figs. 1 and 2 is supposed to cover the housing or the front place 8 of the bearing part 7 and it is presented as an extended cover 14 having attachment or fastening members 15, 16 similar to those provided on the chargers for such tool.

Thus, it is seen on Fig. 2 that the lower end 17 and the higher end 18 of the extended cover 14 comprise attachment elements, such as locking pins 15, 16 able to be engaged into complementary reception areas provided for that purpose on the bearing part 7 and the case 2 of the tool.

The trigger 10 under the form of an extended flat lever is pivotally mounted around a joint axis 20 at the level of its lower end 21, whereas its higher end 22 is ended by a bearing side or flat 23 able to cooperate with the safety means 11. In order to handle the trigger from the outside, a slot 24 being partially crossed by the flat trigger 10 is arranged in the cover of the support 9. The joint axis 20 is orthogonal to the longitudinal axis A of the movable equipment 5, and a torsional spring 25, a branch of which can be seen on Fig. 2, is mounted around the axis 20 to act on the cover and the trigger so that the latter is brought back spontaneously to the first rest or starting position, projecting from the cover.

As an example, the support 9 and the trigger 10 are made in a plastic material which can be reinforced and the support is obtained by moulding or machining. It presents, as it can be seen on Fig. 2, a C-shaped cross-section or similar with a rim applying against the bearing part 7 so as to match at the best to the profile of the latter by extending it appropriately.

Regarding now the anti-firing safety means 11 connected to the case, they comprise in this example a pivoting lever 26 mounted on an axis 27 cooperating with the case and arranged orthogonally to the longitudinal axis A and parallel to the axis 20 of the trigger 10 of the support. Such pivoting lever 26 presents on its free end 28 a projecting part or pin 29 able to engage into a cutout 30 arranged in a yoke-shaped part 31 surrounding a fixed support 34 of the tip guide 6 and which is connected to the movable equipment 5 on a sliding way.

Furthermore, the pivoting lever 26 is itself subjected to the action of a torsional spring, not visible on Figs., tending to bring back spontaneously the pivoting lever in the anti-clockwise direction, as it will be seen subsequently on Figs. 3 and 4, that is to say to move the projecting pin 29 away from the cutout 30 of the yoke 31.

Referring to Figs. 1 and 3, when the cover 14 forming the support 9 is engaged into the reception housing 8 of the case, the trigger 10 mounted on the axis 20 occupies, under the action of the spring 25, the first inactive rest position.

In such position, the flat 23 of the trigger applies under the free end 28 of the lever 26 by pivoting it around the axis 27. In such a way, the projecting pin 29 ending such free end becomes engaged into the cutout 30 of the yoke 31.

As the latter is connected to the movable equipment 5, the tip guide 6 cannot be moved backwards axially by the operator, the lever 26 locking in position the movable equipment 5.

The support 9 of the trigger 10 thus reaches its object to prevent the recoil of the tip guide of a big length, even if the operator holding the tool by the grip 3, grasps the tip guide with his free hand.

To be able to make the firing, the operator must first act on the trigger 10 of the support.

By pushing on the trigger 10 (arrow F, Fig. 4), the latter pivots around the axis 20 in opposition to the action of the torsional spring 25 and enters in great part in the cover 14 through the slot. The rotation of the trigger 10 leads to the

remoteness of the flat 23 from the free end 28 of the locking lever 26.

The latter, under the action of the torsional spring being not visible on the Figs., pivots around the axis 27 in the anti-clockwise direction, that is to say that the projecting pin 29 is moving away from the cutout 30 of the yoke 31, as shown on Fig. 4. It is thus understood that, as long as the operator maintains pressure on the trigger 10 of the support 9, the movable equipment 5 with the tip guide 6 is axially unlocked and cannot then move backwards.

At that time only, the operator can start firing by pushing on the firing control trigger 4. Of course, prior to firing authorization, the operator applies the free end of the tip guide with the fastening member EF (dowel and nail) mounted on the latter against the support material to overcome the usual bearing safety of the tool 1. For example, a compression spring 32 plays as such bearing safety while being provided between the part 31 of the movable equipment and the transversal side 33 of the nose ending the case 2.

It is only by activating such safety and by holding a bearing on the trigger 10 releasing the lever 26 that the operator, also pushing on the control trigger 4 of the tool 1, indicates that firing is authorized. The piston propelled by the source ejects the nail which is driven into the support material while fastening the dowel.

The trigger support then reaches its objective, namely to allow the conversion of a repetitive firing fastening tool with a charger into a

mono-firing fastening tool with a tip guide of a great length for fastening members, the support being in functional relationship with usual anti-firing safety means, preventing the recoil of the tip guide as long  
5 as the trigger of said support is not pushed on.

**WHAT IS CLAIMED IS:**

1. An indirect firing fastening tool comprising, in one case (2), an axially movable equipment (5) with a tip guide (6) projecting from the case to drive a fastening member into a support material, a reception housing (8) for a fastener charger and anti-firing safety means (11) to prevent the recoil of the tip guide,

characterized in that an anti-firing trigger (10) support (9) is mounted on said reception housing to convert the tool into a mono-firing tool, the trigger (10) being arranged to cooperate with the anti-firing safety means (11) so as to remove said anti-firing safety means and authorize firing.

2. The tool according to claim 1, wherein, when there is an absence of cooperation between the trigger (10) and the anti-firing safety means (11), the anti-firing safety means are removed from the equipment and authorize firing.

3. The tool according to claim 1 or 2, wherein said trigger (10) is pivotally mounted around an axis (20) related to the support (9) and projects from the support through a slot (24) arranged in the support.

4. The tool according to claim 1, wherein said trigger (10) is brought back spontaneously in a rest position through an elastic element (25) provided between the support (9) and the trigger (10), thereby locking the recoil of the tip guide through the safety means.

5. The tool according to claim 4, wherein said trigger (10) presents a bearing side (23) acting, when the trigger occupies the rest position, on the anti-firing safety means (11) so as to prevent the recoil of the movable equipment and being removed from the anti-firing safety means when the trigger occupies an active position by a voluntary action on the latter.

6. The tool according to any one of claims 1 to 5, wherein a joint axis (20) of the trigger (10) is orthogonal to the axis of the movable equipment (5).

7. The tool according to any one of claims 1 to 6, wherein the support (9) is present under the form of a cover (14) being adapted to the case (2) reception housing (8) and having fasteners (15, 16) being identical to these of the charger, to cooperate with the case.

8. The tool according to claim 7, wherein the support (9) is made of a plastic material which can be reinforced and the support is obtained by molding or machining.

9. A utilization of a multi-firing tool comprising, in one case, a reception housing for a fastener charger and a reception means for a tip guide,

characterized in that, to convert said multi-firing tool into a mono-firing tool, the tip guide (6) is mounted on the tool and anti-firing safety means are acted on to remove the anti-firing safety means and authorize recoil of the tip guide.

10. The utilization according to claim 9, wherein operation of the anti-firing safety means (11) is performed through a trigger (10) associated with a support (9) mounted on the case reception housing (8).

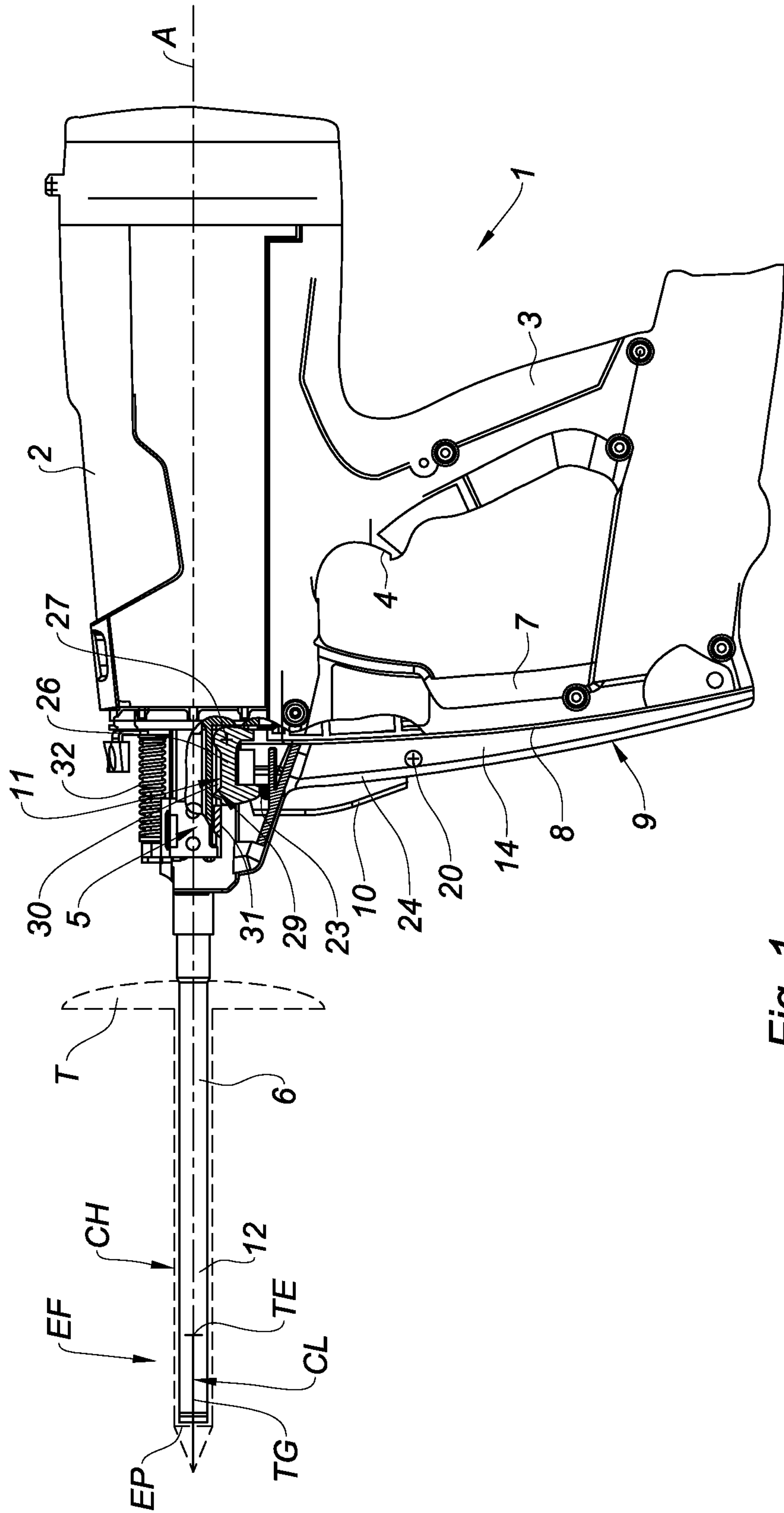

Fig. 1

2 / 3

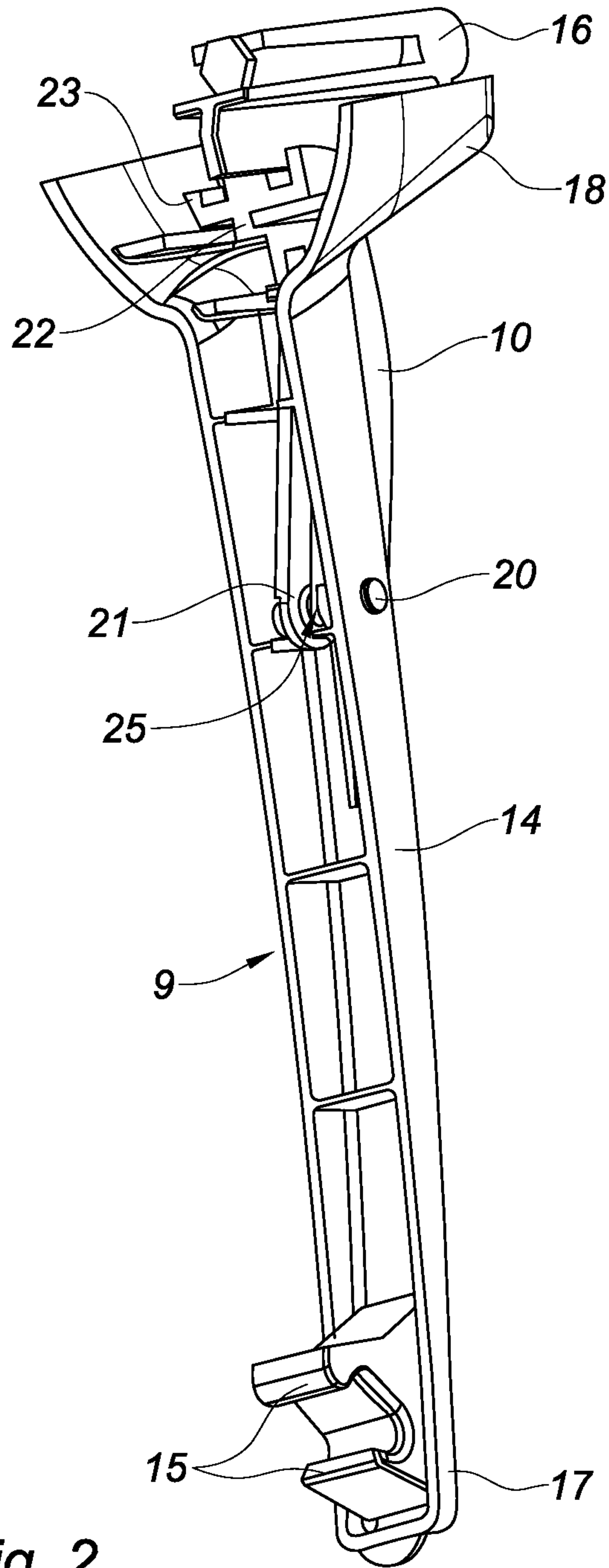

Fig. 2

3 / 3

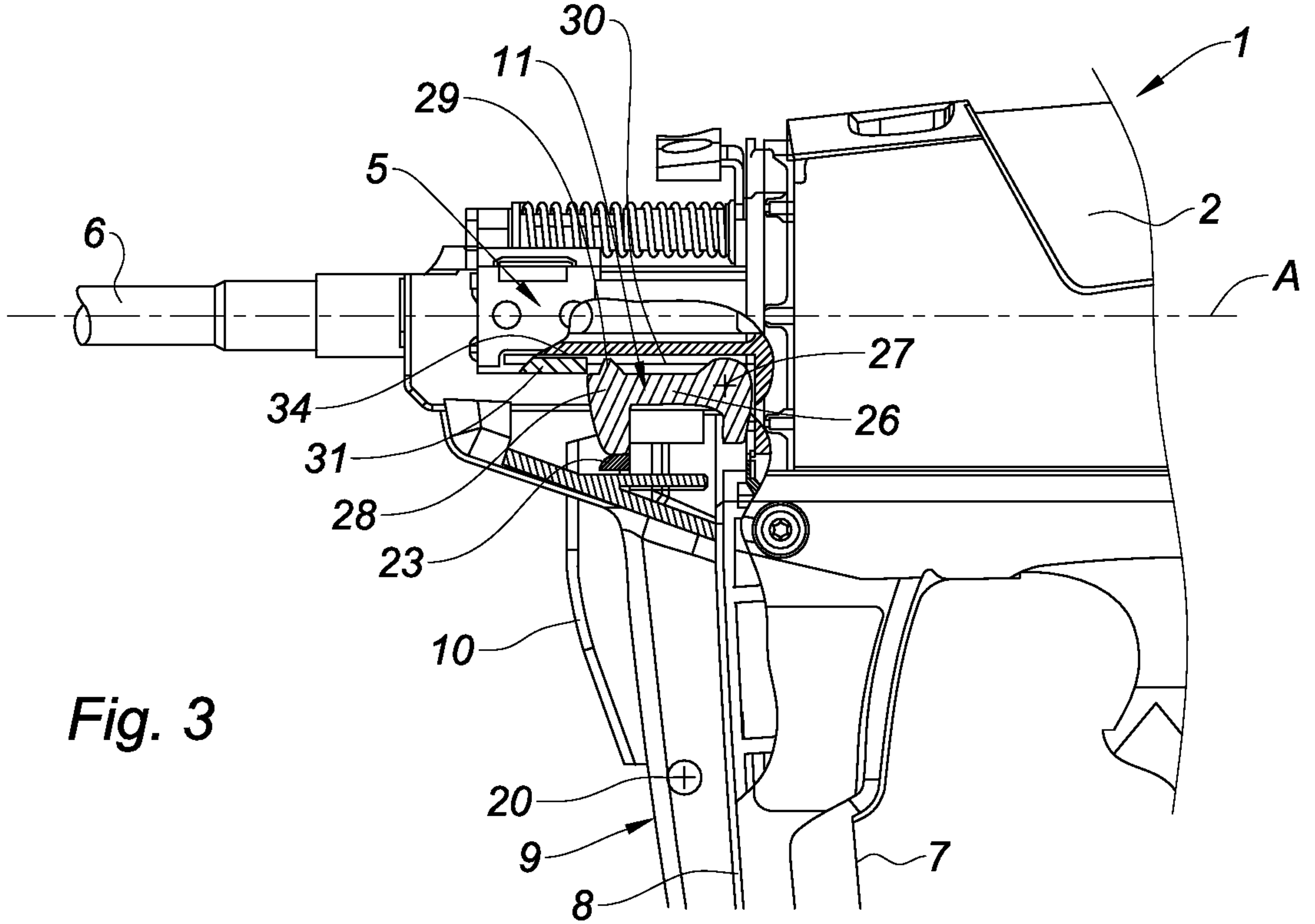

Fig. 3

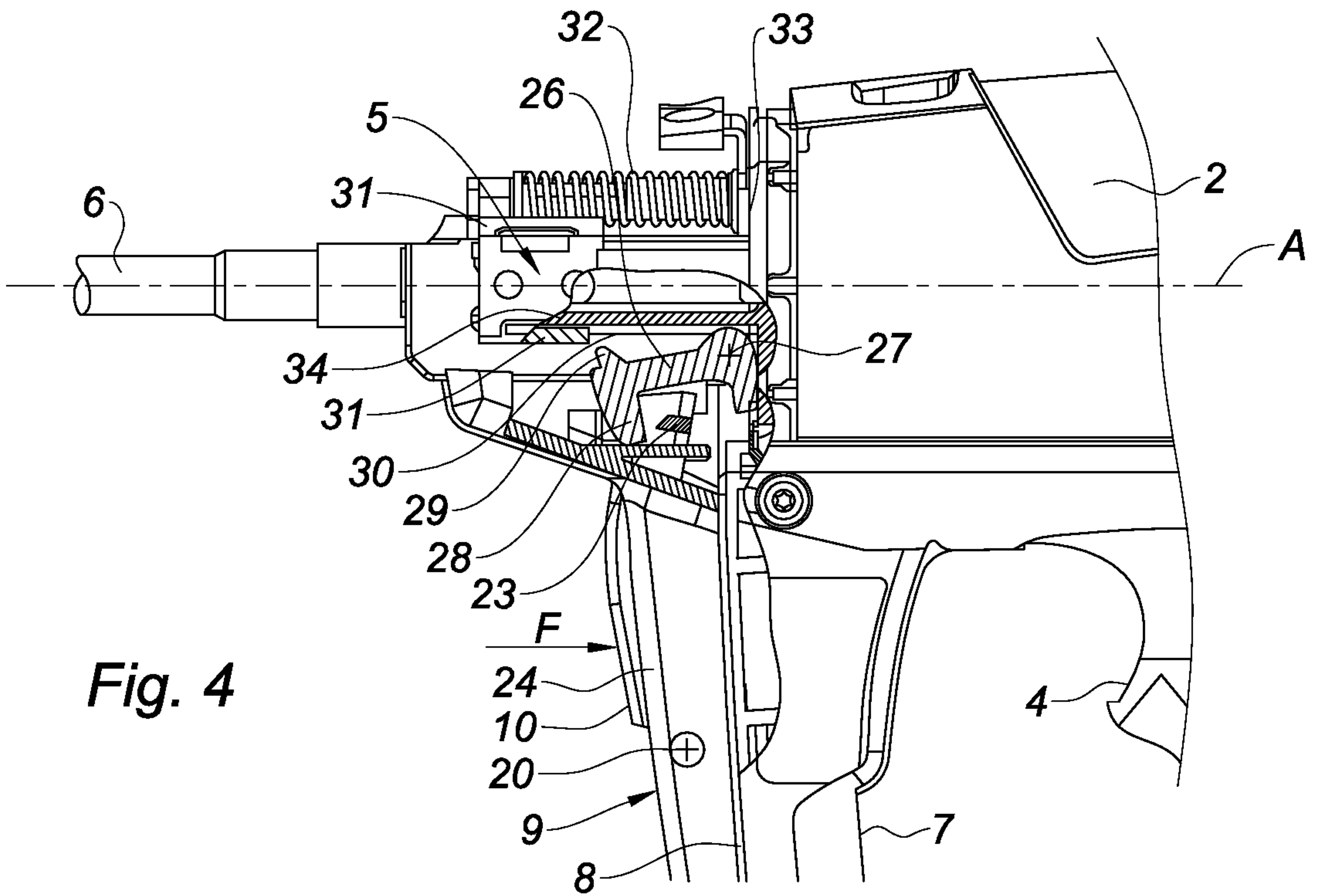

Fig. 4

