

[54] FIRING PIN STOP FOR A FIREARM
 [75] Inventor: Robert E. Roy, East Haven, Conn.
 [73] Assignee: Colt Industries Operating Corp.,
 Hartford, Conn.
 [22] Filed: Oct. 28, 1971
 [21] Appl. No.: 193,502

2,169,084 8/1939 Swartz 89/154

FOREIGN PATENTS OR APPLICATIONS

532,484 11/1921 France..... 42/70 F
 715,176 12/1941 Germany 89/195
 660,046 10/1951 Great Britain..... 42/70 F

Primary Examiner—Benjamin A. Borchelt
 Assistant Examiner—C. T. Jordan
 Attorney—John M. Prutzman et al.

[52] U.S. Cl. 42/70 F
 [51] Int. Cl. F41c 17/04
 [58] Field of Search 42/70 F; 89/154,
 89/194-197

[57] ABSTRACT

A stop mounted in a frame member and engageable with a firing pin preventing its overtravel, the stop being spring biased toward a normally operative position and releasable for disassembly.

[56] References Cited
 UNITED STATES PATENTS
 2,846,925 8/1958 Norman..... 42/70 F

6 Claims, 3 Drawing Figures

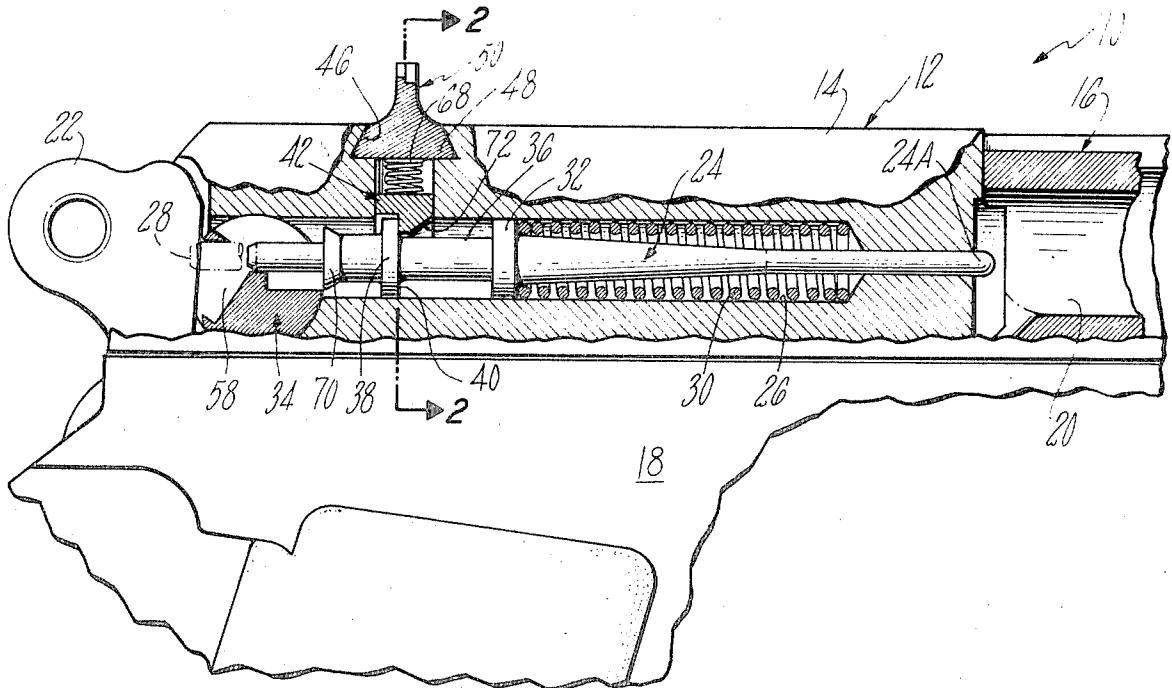

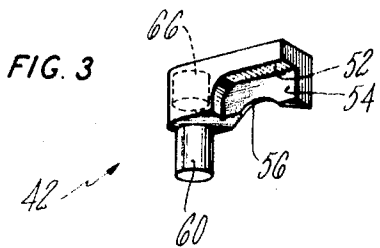
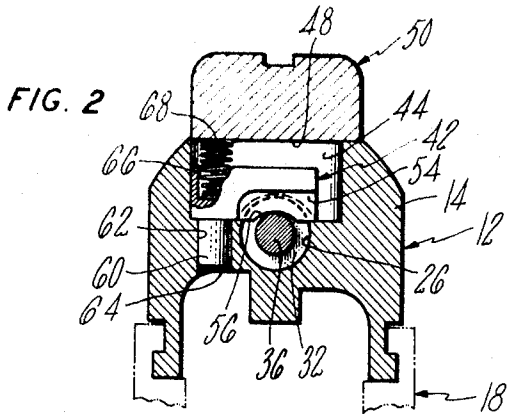
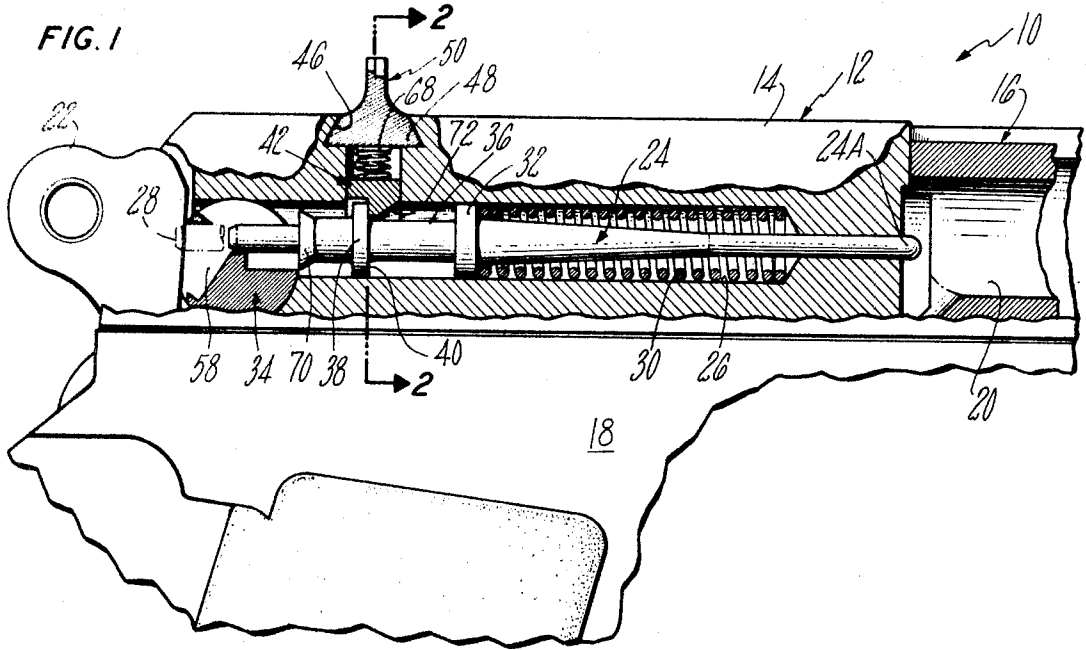

INVENTOR
ROBERT E. ROY

BY *Prutzman, Hayes, Kall and Clifton*
ATTORNEYS

FIRING PIN STOP FOR A FIREARM

FIELD OF THE INVENTION

This invention generally relates to firearms and particularly concerns a safety device preventing firing pin activation during reloading.

BACKGROUND OF THE INVENTION

It has been observed that firing pin binding in a forward position has occurred with various firearms due to a number of factors such as powder fouling, accumulated dirt and even relative minor eccentricities between the firing pin and its passage in a frame member. In certain instances, the firing pin has been known to stick fast a sufficient distance forwardly of the locking safety to permit its being readily moved to a safety "on" condition to effectively lock the firing pin with its striker projecting outwardly through the firing pin passage. When this occurs, e.g., during reloading when a round is normally manually chambered, an extremely dangerous condition exists. A person handling the firearm would have no reason to suspect that the chambered round could be inadvertently fired, particularly since the locking safety is "on." However, accidental firing under these conditions not only is possible during closure of the chamber but indeed is likely to occur before the chamber is completely closed since the pin is locked in a projecting position, resulting not only in damage to the firearm but potentially lethal consequences to any person in close vicinity to the firearm upon explosion of the round.

OBJECTS OF THE INVENTION

Accordingly, a primary object of this invention is to provide an improved safety device for a firearm to minimize any possibility of inadvertently firing during reloading.

Another object of this invention is to provide such an improved safety device which provides continuous control of the firing pin under normal conditions and is particularly suited to permit facile disassembly of the firing pin and associated components.

Other objects will be in part obvious and in part pointed out in more detail hereinafter.

A better understanding of the objects, advantages, features, properties and relationships of the invention will be obtained from the following detailed description and accompanying drawing which sets forth an illustrative embodiment and is indicative of the way in which the principle of the invention is employed.

BRIEF DESCRIPTION OF THE DRAWING

In the drawing:

FIG. 1 is a side view, partly broken away and partly in section, showing a hand gun incorporating this invention;

FIG. 2 is a sectional view, partly broken away, taken generally along line 2-2 of FIG. 1; and

FIG. 3 is an isometric view of a firing pin stop of this invention.

DETAILED DESCRIPTION OF THE DRAWING

Referring in detail to the drawing, it will be understood that while a portion of a pistol 10 is shown for purposes of illustration in FIG. 1 as incorporating a preferred embodiment of this invention, this invention is readily adapted for use in other types of firearms, e.g.,

top break revolvers and other firearms having firing pins of an inertia type.

The piston 10 is shown having an elongated frame member or slide assembly 12 including a slide 14 and barrel 16 mounted for longitudinal reciprocating movement on a receiver 18. The pistol 10 may be assumed to be a magazine fed, gas recoil operated automatic pistol of a well-known type wherein the slide assembly 12 is driven rearwardly by the by-products of combustion upon firing of a round in a chamber 20 of the barrel 16 to automatically extract and eject a spent cartridge case and cock a spring biased hammer 22 during rearward movement of the slide 14 relative to the barrel 16 and receiver 18.

Upon return slide movement toward a forward position to re-engage the barrel 16 and condition the pistol 10 for the firing of the next round, the slide 14 automatically strips a top cartridge from a magazine, not shown, and chambers that round in the barrel 16. Upon trigger squeeze, causing the hammer 22 to drop, an elongated firing pin 24 such as that shown in FIG. 1 is thrust forwardly to detonate a primer, not shown, of the chambered round and automatically effect the above-described rearward movement of the recoiling mass.

The pin 24 is received in a longitudinally extending passage 26 formed in the slide 14 and is reciprocable between a rear operative limit position, represented by broken lines at 28, and a forward cartridge firing position shown in full lines in FIG. 1. The firing pin 24 shown is of an inertia type requiring a full hammer drop to drive the firing pin from its rear limit position to its forward cartridge firing position. The pin 24 is continuously biased rearwardly toward its rear operative limit position by a coil spring 30 received in the passage 26. One end of the spring 30 seats against the body of the slide 14 adjacent a forward reduced end of the passage 26 facing the barrel chamber 20, and an opposite end of the spring 30 seats against a radial flange 32 circumferentially extending about the pin 24 intermediate its opposite ends.

A conventional rotary locking safety 34 is shown supported in the slide 14 at an extreme rear end of the firing pin passage 26 for rotation about an axis extending transversely to the longitudinal axis of slide 14. Rotary safety 34 may be operated in a customary manner by manual manipulation of an operating lever, not shown, between a detented safety "off" condition (illustrated in FIG. 1) and a detented safety "on" condition displaced angularly clockwise from that shown in the drawing and wherein a solid metal block portion of the rotary safety 34 is positioned in obstructing relation between hammer 22 and pin 24, isolating the pin from the impact of any hammer drop.

Should any binding of the pin 24 within its passage 26 occur for any reason whatsoever when the firing pin striker 24A has been driven forwardly to project through the passage 26 with pin 24 in its entirety positioned forwardly of safety 34, a round could be manually dropped into the chamber 20, e.g., during the normal course of reloading with slide 14 retracted relative to receiver 18, and the safety 34 could be activated to its safety "on" condition and positively lock the firing pin 24 in its forwardly projecting position. Should this occur, a person may be unaware of the potential danger and believe the firearm to be completely safe. Should the slide 14 then be released in the usual manner to close the barrel chamber 20, the slide 14 would be

driven forwardly by its action spring, not shown, and the chambered round would be fired, similarly to a slam fired submachine gun. This action would result in the firearm being fired with the slide 14 and the barrel 16 still in relatively unlocked condition before the chamber 20 is closed.

To minimize any possibility of such overtravel of the firing pin 24 relative to the safety 34 with the firing pin 24 in its entirety remaining in a position forward of the safety 34, the firing pin 24 is shown formed with an intermediate portion 36 of reduced cross section relative to the flange 32 and a rearwardly spaced coaxial radial flange 38 of generally equal diameter to that of flange 32 and which provides a radial shoulder 40 engageable with a stop or latch 42 mounted in the slide 14 in overlying relation to the passage 26 for maintaining control over the pin 24 and ensuring its being in continuous operative engagement with the safety 34 under normal conditions.

More specifically, the latch 42 is supported within a relatively enlarged latch chamber 44 of generally rectangular cross section shown communicating with the firing pin passage 26 and disposed immediately below a dove-shaped groove 46 extending transversely across an upper rear surface of the slide 14 with a correspondingly shaped base 48 of a rear sight 50 being shown mounted with the groove 46 in the slide 14.

A relieved cutout portion 52 is formed in a lower rear wall portion of the latch 42 providing a rearwardly facing, vertically extending planar stop surface 54 engageable with the radial shoulder 40 of the pin 24 to positively limit its forward travel and preclude firing pin movement beyond the forward cartridge firing position or the forward operative limit position shown in full lines in FIG. 1. The stop surface 54 of the latch 42 is shown (FIG. 2) having an arcuate central lower edge 56 generally corresponding to the upper surface contour of the reduced intermediate portion 36 of the pin 24 between the flanges 32, 38 to permit the firing pin 24 to be freely driven forwardly under hammer impact and returned under the influence of its spring 30 without binding up on the latch 42.

With the hammer 22 in its illustrated dropped position, the pin 24 will normally seat against the hammer 22, it being understood that the firing pin 24 is shown for illustrative purposes in its cartridge firing position. Upon cocking the hammer 22, the spring bias of the firing pin 24 will be understood to move the pin rearwardly, a discrete distance from its seated position against the hammer 22, to an extent limited by seating engagement of the firing pin 24 with the safety 34.

In any event, the latch 42 under normal conditions will continuously maintain the rear end of the firing pin 24 in alignment with and confined within a contoured firing pin opening 58 formed in the locking safety 34 irrespective of its being in safety "on" or safety "off" conditions, thereby to preclude any overtravel of the firing pin 24 relative to its locking safety 34. Should the firing pin 24 become bound up within its passage 26 in a forwardly projecting position, the above-described latch construction incorporated within the firearm of this invention ensures that the firing pin 24 will not be accidentally locked by activation of the safety 34 to a safety "on" condition, but rather will always be conditioned for rearward movement into the firing pin opening 58 within the confines of the safety 34 upon any force being applied to the striker 24A projecting be-

yond the passage 26. Accordingly, any danger of accidental firing of a manually chambered round during the reloading upon release of the slide 14 is significantly minimized. Any binding of the pin 24 in a forwardly projecting position would normally result in a rearward displacement of its striker 24A upon contacting the chambered round without detonating its primer.

To positively locate the latch 42 and to also facilitate disassembly of the firing pin 24 and the rotary safety 34, a depending actuator or post 60 is shown preferably formed as an integral part of the latch 42 extending downwardly in offset relation to its arcuate lower edge 56 for receipt within a generally vertically extending passage 62 of slightly enlarged size relative to the post 60 and having an exposed opening in an upper interior wall surface 64 of the slide 14. A recess 66 is shown formed in an upper portion of the latch 42 in generally aligned relation to the depending post 60 providing a seat for one end of a coil spring 68 having its opposite end seated against the base 48 of the rear sight 50.

To disassemble the firing pin 24 from the slide 14, the slide 14 is removed from the receiver 18 whereupon the post 60 is exposed so as to simply be pressed inwardly to move the stop surface 54 upwardly into the clearance within the latch chamber 44 a distance sufficient to permit the pin 24 to be moved forwardly in the passage 26 against the bias of its spring 30 and allow the safety 34 to be removed laterally outwardly relative to the slide 14. In this regard, a rear collar 70 on the firing pin 24 may be of additional benefit for, upon depressing the firing pin 24 forwardly with the latch 42 retracted, the collar 70 may be removed forwardly with the latch 42 retracted, the collar 70 may be moved forwardly of the latch 42 which upon being released engages the collar 70 to temporarily retain the pin 24 in noninterfering relation to the safety 34 which then may be quickly and easily withdrawn. With the safety 34 removed, the post 60 of the latch 42 may once again be depressed, and the compressed spring 30 will assist in forcing the pin 24 rearwardly to be removed from the slide 14. The front face of the latch 42 is shown preferably chamfered at 72 to facilitate removal of the firing pin 24.

Reassembly of the firing pin 24 and safety 34 is simply accomplished by a reverse sequence of the above described steps. Complete removal of the latch 42 and spring 30 from the latch chamber 44 is accomplished by lateral displacement of the rear sight 50 and removal from the slide 14.

The spring biased firing pin stop of this invention provides continuous control of the firing pin and effectively minimizes any possibility of firing pin overtravel and potentially lethal consequences during reloading of the firearm. A spring biased firing pin stop of the above-described construction will serve to continuously maintain the firing pin in engagement with the safety under all normal conditions and will ensure against any person handling the firearm of being misled into a feeling of false security when the safety is in "on" condition. In addition, the design of the disclosed construction wherein the latch is supported below the rear sight carried on the slide covers any machining required in that area containing the latch. As a result, no protrusions, pin holes or other machining or exterior structural components are in evidence indicative of the additional structure incorporated within the slide which remains aesthetically pleasing.

As will be apparent to persons skilled in the art, various modifications, adaptations and variations of the foregoing specific disclosure can be made without departing from the teachings of the present invention.

I claim:

1. A safety device for a firearm comprising a frame member having an elongated firing pin passage, a locking safety mounted on the frame member to extend transversely across a rear end of the firing pin passage and supported for rotary movements between safety "on" and safety off" conditions, the safety having a firing pin opening therein communicating with the rear end of the firing pin passage in both safety "on" and safety "off" conditions, an elongated, hammer actuated firing pin received in the passage of the frame member for reciprocating movements between forward and rear operative limit positions, the firing pin being continuously biased toward its rear operative limit position for hammer engagement, the firing pin having an abutment shoulder formed on the firing pin, and a firing pin stop mounted in the frame member and projecting into its firing pin passage in interfering relation to the path of movement of the firing pin abutment shoulder, the firing pin stop being engageable with the abutment shoulder to define the forward operative limit position of the firing pin, the firing pin stop and the abutment shoulder of the firing pin jointly serving to maintain a portion of the firing pin within the firing pin opening of the safety during movements of the firing pin between its forward and rear operative limit positions and confining the firing pin within the firing pin opening upon engagement of the firing pin abutment shoulder with the firing pin stop in said forward operative limit position of the pin, whereby the abutment shoulder of the firing pin positively prevents the firing pin overtravel forwardly of the safety and out of its firing pin opening and also to prevent inadvertent locking of the pin forwardly of the safety upon activating it to a safety "on" condition.

2. The safety device of claim 1 wherein the frame member includes a chamber communicating with the firing pin passage, wherein a latch is received within the chamber for movement toward and away from the firing pin passage, and wherein a spring is received within the latch chamber continuously urging the latch toward the firing pin passage, the latch having a portion thereon constituting said firing pin stop engageable with the firing pin abutment shoulder.

3. The safety device of claim 2 wherein the frame member includes a rear sight mounted on an upper rear surface of the frame member, and wherein the latch chamber is disposed in underlying relation to the rear sight with the rear sight serving as a closure for the latch chamber, the latch spring being seated against the rear sight and continuously urging the latch toward the firing pin passage.

4. The safety device of claim 2 wherein the frame member includes an opening extending from the latch

chamber through the frame member, and wherein a manually operable actuator is received within the frame member opening and is operatively connected to the latch for moving the latching against the bias of the latch spring force upon operating the actuator and permitting the firing pin stop to be moved forwardly of its forward operative limit position into disengaged relation to the locking safety for disassembly of the locking safety and removal of the firing pin from its passage.

5. The safety device of claim 1 wherein the locking safety serves as a stop for the firing pin in its rear operative limit position under a hammer cocked condition.

6. A safety device for a firearm comprising a frame member having an elongated firing pin passage, a locking safety supported on the frame member and movable between safety "on" and safety "off" conditions, the safety having a firing pin opening therein communicating with the firing pin passage in both safety "on" and safety "off" conditions, an elongated, hammer actuated firing pin received in the passage of the frame member for reciprocating movements between forward and rear operative limit positions, the firing pin being continuously biased toward its rear operative limit position for hammer engagement and having an abutment shoulder formed on the firing pin, and a firing pin stop mounted in the frame member and projecting into its firing pin passage in interfering relation to the path of movement of the firing pin for engagement with its abutment shoulder and defining its forward operative limit position, the firing pin stop serving to continuously maintain a portion of the firing pin within the firing pin opening of the safety during movements of the firing pin between its forward and rear operative limit positions, the frame member including a chamber communicating with the firing pin passage, a latch received within the chamber for movement toward and away from the firing pin passage, and a spring received within the latch chamber continuously urging the latch toward the firing pin passage, the latch having a portion thereon constituting said firing pin stop engageable with the firing pin abutment shoulder, the frame member including an opening extending from the latch chamber through the frame member, and a manually operable actuator received within the frame member opening and operatively connected to the latch for moving the latch against the bias of the latch spring force upon operating the actuator and permitting the firing pin stop to be moved forwardly of its forward operative limit position into disengaged relation to the locking safety for disassembly of the locking safety and removal of the firing pin from its passage, the firing pin stop of the latch having a surface thereon normally positioned within the firing pin passage and facing forwardly therein, the surface being chamfered to facilitate removal of the firing pin rearwardly from its passage.

* * * * *

UNITED STATES PATENT OFFICE
CERTIFICATE OF CORRECTION

Patent No. 3,750,319 Dated August 7, 1973

Inventor(s) Robert E. Roy

It is certified that error appears in the above-identified patent and that said Letters Patent are hereby corrected as shown below:

Column 2, line 8, cancel "tupe" and substitute therefor
--type--.

Column 2, line 16, cancel "pisto" and substitute therefor
--pistol--.

Column 2, line 20, cancel "hammber" and substitute therefor
--hammer--.

Column 3, line 20, cancel "Mor" and substitute therefor --More--.

Column 3, line 27, cancel "with" and substitute therefor
--within--.

Column 3, line 41, cancel "sprin" and substitute therefor
--spring--.

Column 3, line 43, cancel "hamemr" and substitute therefor
--hammer--.

Column 4, line 5, cancel "plsition" and substitute therefor
--position--.

Column 4, line 6, cancel "isplacement" and substitute therefor
--displacement--.

Column 4, line 32, cancel "removed" and substitute therefor
--moved--.

Column 4, line 32, cancel "with" and substitute therefor --of--.

UNITED STATES PATENT OFFICE
CERTIFICATE OF CORRECTION

Patent No. 3,750,319 Dated August 7, 1973

Inventor(s) Robert E. Roy Page - 2

It is certified that error appears in the above-identified patent and that said Letters Patent are hereby corrected as shown below:

Column 4, lines 33-34, cancel "retracted, the collar 70 . . . the latch 42".

Column 4, line 53, cancel "releading" and substitute therefor --reloading--.

Column 5, line 7, cancel "pasage" and substitute therefor --passage--.

Column 5, line 11, insert --"-- before --off--.

Column 5, line 41, cancel "communicatiang" and substitute therefor --communicating--.

Column 5, line 55, cancel "uring" and substitute therefor --urging--.

Column 6, line 4, cancel "latching" and substitute therefor --latch--.

Column 6, line 12, cancel "h" before --hammer--.

Column 6, lines 43 and 44, cancel "including an opening . . . chamber".

Column 6, line 51, cancel "disassebmoy" and substitute therefor --disassembly--.

Signed and sealed this 27th day of November 1973.

(SEAL)
Attest:

EDWARD M. FLETCHER, JR.
Attesting Officer

RENE D. TEGTMEYER
Acting Commissioner of Patents