

(19) **DANMARK**

(10) **DK/EP 3990809 T3**



(12) **Oversættelse af  
europæisk patentskrift**

Patent- og  
Varemærkestyrelsen

- 
- (51) Int.Cl.: **F 16 K 1/02 (2006.01)**                      **A 61 M 16/00 (2006.01)**                      **A 61 M 16/01 (2006.01)**  
**A 61 M 16/06 (2006.01)**                      **A 61 M 16/20 (2006.01)**                      **F 16 K 27/02 (2006.01)**  
**F 16 K 35/10 (2006.01)**
- (45) Oversættelsen bekendtgjort den: **2023-07-03**
- (80) Dato for Den Europæiske Patentmyndigheds bekendtgørelse om meddelelse af patentet: **2023-05-10**
- (86) Europæisk ansøgning nr.: **20742652.9**
- (86) Europæisk indleveringsdag: **2020-06-25**
- (87) Den europæiske ansøgnings publiceringsdag: **2022-05-04**
- (86) International ansøgning nr.: **EP2020067950**
- (87) Internationalt publikationsnr.: **WO2020260536**
- (30) Prioritet: **2019-06-25 GB 201909121**
- (84) Designerede stater: **AL AT BE BG CH CY CZ DE DK EE ES FI FR GB GR HR HU IE IS IT LI LT LU LV MC MK MT NL NO PL PT RO RS SE SI SK SM TR**
- (73) Patenthaver: **Intersurgical AG, Meierhofstrasse 5, 9490 Vaduz, Liechtenstein**
- (72) Opfinder: **BOTTOM, David Simon, c/o Intersurgical Limited, Crane House, Molly Millars Lane, Wokingham, Berkshire RG41 2RZ, Storbritannien**  
**BOOTH, Christopher Edgerly, c/o Intersurgical Limited Crane House Molly, Millars Lane, Wokingham Berkshire RG41 2RZ, Storbritannien**  
**PAYNE, Simon Robert, c/o Intersurgical Limited Crane House Molly, Millars Lane, Wokingham Berkshire RG41 2RZ, Storbritannien**  
**BOWSHER, Richard Francis, c/o Intersurgical Limited, Crane House, Molly Millars Lane, Wokingham, Berkshire RG41 2RZ, Storbritannien**
- (74) Fuldmægtig i Danmark: **NORDIC PATENT SERVICE A/S, Bredgade 30, 1260 København K, Danmark**
- (54) Benævnelse: **JUSTERBAR VENTIL**
- (56) Fremdragne publikationer:  
**EP-A2- 1 228 781**  
**WO-A1-2014/129407**  
**US-A- 5 294 093**  
**US-A1- 2002 104 569**  
**US-A1- 2010 206 310**



# DESCRIPTION

**[0001]** The present invention relates to adjustable flow control valves, for example to an Adjustable Pressure Limiting (APL) valve.

**[0002]** An APL valve (sometimes referred to as an expiratory valve, relief valve or spill valve) is a type of flow control valve used in anaesthesiology as part of a breathing system. It allows excess fresh gas flow and exhaled gases to leave the system while preventing ambient air from entering.

**[0003]** APL valves comprise a thin disc shaped sealing member, held in place against a valve seat by a spring. Very light springs are typically used, to ensure that the valve can be opened just by a patient's breathing at low pressures. However, the opening pressure of the spring-loaded valve member can be increased by rotating a part of the valve top to compress the spring. The APL valve thus provides an adjustable limit pressure at which the valve member will open. In some instances, the valve can be configured so that rotating the same part of the valve top in an opposite direction can entirely remove the spring force from the valve member so that the valve has an open configuration.

**[0004]** It is important to the intended operation of APL valves that their maximum limit pressure is accurate and known. When manufacturing an APL valve, the target for maximum limit pressure may be 60 cmH<sub>2</sub>O, for example. However, this can be difficult to achieve reliably/repeatably. The spring force provided by springs, in particular light springs, can vary. This, together with other manufacturing tolerances, often means that some springs will need compressing more than others to achieve a setting as close to 60 cmH<sub>2</sub>O as possible.

**[0005]** It may be tempting to use a slightly stronger spring than necessary in order to ensure that all valves are capable of achieving the target. However, this would undesirably increase the pressure needed to open the APL valve at the low end of its operating range, and if the maximum limit pressure of a valve is higher than indicated a valve may not open at all.

**[0006]** A need existed, therefore, for an improved APL valve allow greater accuracy in the setting of the maximum pressure the valve allows.

**[0007]** US 2010/0206310 discloses a pressure controller with a control valve and an elastic biasing means for biasing the control valve against a valve seat. A cap 28 has a first configuration in which it can be rotated to adjust the biasing force from the elastic biasing means, and a second configuration in which rotation does not adjust the biasing force. This provides a pressure controller capable of reliably preventing unwanted adjustment while the operation remains simple as a whole.

**[0008]** In summary, the valve of the invention comprises a first valve cap that can be used to adjust the force applied to a valve member by a biasing element, and a second valve cap that

can be engaged with the first valve cap to prevent further adjustment beyond a predetermined maximum desired limit. For example, the valve may comprise a first or inner cap that can be rotated to move down a thread on the valve body, increasing the force applied by a spring to a valve member. When the pressure is as close to a target value (for example 60 cmH<sub>2</sub>O) as possible a second, outer, valve cap then fits over the first/inner valve cap. The valve caps engage so that they cannot be rotated relative to one another, and corresponding abutment features on the second/outer valve cap and valve body are aligned to abut one another and prevent any further rotation to further compress the spring and thus prevent the pressure being set any higher.

**[0009]** Valves are known where an inner cap can be rotated to adjust a threshold pressure as described and then locked in place by an outer cap fixed or locked onto the valve body. However, in these valves, once the threshold pressure is set at a predetermined level (for example at 60 cmH<sub>2</sub>O) it cannot be changed/adjusted at all.

**[0010]** By instead fixing the second/outer cap to the first/inner cap rather than the valve body, the valve of the present invention allows the maximum pressure to be adjusted as necessary and fixed, for example by a stop or abutment member, while still allowing adjustment of the valve during use so that a lower pressure can be delivered when needed. The first/inner cap can still be turned away from the stop to reduce pressure down towards 0.

**[0011]** Typically, where a valve provides an adjustable operating pressure with a maximum pressure threshold, the maximum pressure threshold is fixed during manufacture of the device (eg through the positioning of a stop on the screw fitting). However, this does not allow for any adjustment or 'fine tuning' of the valve, and therefore relies on very high consistency of springs and other valve components to achieve a reliable and consistent threshold across a number of individual valves or batches.

**[0012]** By providing a valve where the maximum pressure is finally set post-manufacture, by including a second cap as discussed, differences in springs or slight variations in manufacturing tolerances can be accommodated and corrected so that a quoted threshold pressure can be ensured.

**[0013]** According to the present invention there is provided an adjustable valve as defined in the appended claim 1. Further optional features are recited in the associated dependent claims.

**[0014]** The adjustable valve comprises a valve body comprising a valve seat, a valve member movable relative to the valve seat, a first valve cap, a second valve cap, and a biasing element provided between the first valve cap and the valve member such that the first valve member is biased away from the first valve cap by a biasing force from the biasing element. The first valve cap is movable within a defined range of motion relative to the valve body such that movement of the first cap in a first direction increases the biasing force applied by the biasing element and the second valve cap is engageable with the first valve cap at a plurality of positions of the first

valve cap within its defined range of motion to prevent movement of the first valve cap in said first direction beyond a selected one of said plurality of positions but to allow movement of the valve cap in a second direction, opposite to said first direction, within said defined range of motion.

**[0015]** The adjustable valve allows the final setting of a maximum, or minimum, limit pressure during assembly, while still providing pressure adjustment during use. The second valve cap may comprise a first abutment stop and the valve body may comprise a second abutment stop. Abutment of the first and second abutment stops may prevent movement of the first valve cap in said first direction.

**[0016]** The first abutment stop and/or the second abutment stop may comprise a projection of material, for example from valve body and/or from the second valve cap.

**[0017]** The first and second abutment stops may be moved into contact during engagement of the second valve cap with the first valve cap. The contact may comprise side-by-side abutment of the first and second abutment stops.

**[0018]** The valve body may comprise a screw thread to provide the defined range of motion for the first valve cap, and the first direction of movement of the first valve cap may comprise clockwise rotation relative to the valve body.

**[0019]** The first valve cap and/or second valve may be configured to resist relative movement of the second valve cap relative to the first valve cap once the second valve cap is engaged with the first valve cap. For example, the first valve cap and second valve cap may be sized to engage with an interference fit and/or at least one of the first valve cap and second valve cap may comprise one or more engagement features, such as clips, to resist disengagement of the second valve cap from the first valve cap. The outer cap may, for example, clip onto the inner cap to prevent removal of the outer cap after assembly.

**[0020]** The first valve cap and second valve cap may comprise corresponding engagement features, for example ridges and grooves or keys and splines, to prevent rotation of the second valve cap relative to the first valve cap.

**[0021]** The valve body or the first valve cap may comprise a plurality of detents to define the plurality of positions of the first valve cap as a series of defined adjustment steps. The plurality of detents may be provided by a textured or ridged surface on the valve body, for example on an interior surface of the valve body, to engage with a feature on the interior of the first valve cap. The plurality of detents may be evenly spaced.

**[0022]** Alternatively, stepless adjustment may be provided between the first valve cap and the valve body.

**[0023]** The biasing element of the valve may comprise a compression spring.

**[0024]** A breathing system is also provided comprising a fresh gas inlet, a first outlet connectable to a user interface, and an adjustable valve as defined above provided at a second outlet located between the fresh gas inlet and the first outlet. The breathing system may further comprise a reservoir bag.

**[0025]** The invention also provides a method of setting an adjustable valve as defined in the appended claim 12. Further optional features are recited in the associated dependent claims.

**[0026]** The method comprises the steps of rotating a threaded adjuster relative to a valve housing to set a desired valve opening pressure and subsequently engaging a locking cap with the threaded adjuster such that a part of the locking cap abuts a part of the valve housing to prevent rotation of the threaded adjuster in a first direction but to permit rotation of the threaded adjuster in a second, opposite, direction.

**[0027]** The first direction may be a clockwise direction and the second direction may be an anticlockwise direction.

**[0028]** Engaging the locking cap with the threaded adjuster may permanently secure the locking cap to the threaded adjuster.

**[0029]** The method may be applied to the adjustable valve as previously described.

**[0030]** Wherever practicable, any of the essential or preferable features defined in relation to any one aspect of the invention may be applied to any further aspect. Accordingly, the invention may comprise various alternative configurations of the features defined above.

**[0031]** Practicable embodiments of the present will now be described with reference to the accompanying drawings, of which:

Figure 1 is a cross-sectional perspective view of an incomplete APL valve according to the present invention;

Figure 2 is a perspective view of a first rotatable cap of the APL valve of Figure 1;

Figure 3 is a cross-sectional view showing the internal components of the APL valve of Figure 1;

Figures 4A and 4B are perspective views showing adjustment of the APL valve of Figure 1;

Figures 5A and 5B are perspective views showing the APL valve of Figure 1 with a second rotatable cap for setting a threshold pressure;

Figure 6 is a cross-sectional view of the top of a complete APL valve as shown in Figure 5B; and

Figure 7 is a schematic view of a breathing system incorporating an APL valve according to the

present invention.

**[0032]** A part assembled APL valve 2 is shown in Figure 1. The valve 2 comprises a valve body 4 with an internally provided valve seat 6. The valve seat 6 is a generally cylindrical opening which can be closed by a generally circular disc shaped resilient element 8 on the lower side of a valve member 10. A generally tubular stem 12 extends from an upper side of the valve member 10 and is slidably received in a tubular opening 22 in a first valve cap 20. The movement of the valve member 10 is thus constrained by the cap 20 to vertical movement towards and away from the valve seat 6.

**[0033]** A coil spring 30 is provided between the cap 20 and valve member 10 to bias the valve member away from the cap 20. The cap 20 engages with a screw thread 32 on the exterior of the valve body 4, such that rotation of the cap 20 adjusts the vertical position of the cap 20 and valve member 10 relative to the valve seat 6. As illustrated in Figure 1, the resilient element 8 of the valve member 10 is spaced from the valve seat 6 and the coil spring 30 is fully extended. It will be understood, however, that further movement of the cap 20 towards the valve seat once the resilient element 8 engages with the valve seat 6 will compress the coil spring 30 and thus increase the spring force applied to the valve member 10. This in turn allows a variation in the amount of pressure required to open the valve member 10 and allow gas flow from an inlet 34 to an outlet 36.

**[0034]** The interior of the first valve cap 20 can be seen in Figure 2. A set of support ridges 24 are provided within the tubular opening 22, and a set of external ridges 26 are provided around the exterior of the cap 20. Circumferential teeth or lugs 28, for engaging with the screw thread 32 on the valve body 4, can also be seen on an internal circumferential face of the cap 20. The lugs 26 clip into the screw thread 32 to hold the cap 20 on the valve body 4 and constrain rotation of the cap 20 within the screw thread 32 provided. A resiliently flexible ratchet tooth 38 is also shown facing radially outward towards this circumferential face.

**[0035]** The cross-sectional view of Figure 3 shows the engagement of the circumferential teeth 28 of the cap 20 with the screw thread 32 on the valve body 4. An enlarged diameter portion 14 at a free end of the stem 12 of the valve member 10 is supported on the support ridges 24 of the cap 20. This helps to hold the valve member 10 against the biasing force of the coil spring 30, which is lightly compressed to ensure that it is seated and retained between the cap 20 and an annular rebate/stepped area 16 at the peripheral edge of the valve member 10. A textured/ridged surface 40 is also visible on the interior of the valve body. The radial tooth 38 of the cap 20 engages with this surface 40 to provide a stepped adjustment during rotation of the cap 20 relative to the valve body 4. This provides feedback during rotation and helps to maintain the cap 20 in a desired position, but the ridged surface 40 and/or radial tooth 38 could be omitted if finer, or stepless, adjustment is more desirable.

**[0036]** Figures 4A and 4B show the adjustment of the first valve cap 20 to set a desired

threshold pressure for the valve 2. In Figure 4A the first valve cap 20 is in a similar position to that shown in Figures 1 and 3. The majority of the screw thread 32 is visible, and inside the valve body 4 the resilient element 8 of the valve member 10 is spaced from the valve seat 6. Clockwise rotation 42 of the first cap 20 will first move the valve member 10 towards the valve seat, and subsequently compress the coil spring 30 to increase the spring force provided to the valve member. During this adjustment, the valve 2 can be repeatably tested by applying a known gas pressure at the inlet 34 and monitoring gas flow at the outlet 36 of the valve 2.

**[0037]** Figure 4B shows the same valve 2 adjusted to provide a threshold pressure set as close to 60 cmH<sub>2</sub>O as possible. The cap has been rotated clockwise 42 from the position shown in Figure 4A to screw the cap 20 down onto the valve body 4. The top of the stem 12 of the valve member 10 can be seen through the tubular opening 22 in the top of the first valve cap 20, forced upwards by the resilient element 8 of the valve member 10 engaging the valve seat 6 and compressing the spring 30 between the cap 20 and the valve member 10.

**[0038]** In an ideal world, the strength of the spring 30 and the area of the valve seat 6 in the illustrated example could simply be selected to provide a maximum threshold pressure of, for example, 60cmH<sub>2</sub>O for the valve 2 when the cap 20 is fully tightened. However, in practice manufacturing tolerances in both the spring 30 and in the moulding of the valve seat 6 would lead to undesirable variations in threshold pressure between different valves 2, for example creating a threshold pressure of anywhere between 50 and 60 cmH<sub>2</sub>O.

**[0039]** To help avoid producing a valve that provides too low a threshold pressure, elements of the valve 2 can be designed to provide a higher threshold pressure than required, for example 70 cmH<sub>2</sub>O when fully tightened, so that natural manufacturing variations should provide a threshold pressure of 60 to 70 cmH<sub>2</sub>O. The higher threshold pressure can then be reduced, if necessary, during final assembly of the valve 2 by simply not fully tightening the first valve cap 20. For example, the valve shown in Figure 4B has been adjusted so that the cap 20 is approximately 45 degrees 44 from being fully tightened, which equates to about 8 cmH<sub>2</sub>O. This position has been determined to provide a threshold pressure as close as possible to 60 cmH<sub>2</sub>O for the particular combination of components in the valve 2.

**[0040]** Once a desired threshold pressure is set, it is clearly important to prevent further rotation of the first valve cap 20 in the clockwise direction 42. This is achieved through the engagement of a second valve cap, designed to fit over the first valve cap 20 and engage with a first abutment stop 46 provided on the valve body 4.

**[0041]** Figures 5A and 5B shown the fitting of the second valve cap 50. A projection 48 on the second valve cap 50 provides a second abutment stop 48 for engagement with the first abutment stop 46 on the valve body 4. Recesses (not shown) are provided on the interior of the second cap 50 to engage with the ridges 26 on the exterior surface first valve cap 20 as the second valve cap 50 is pushed down 52 into place. This provides a key and spline engagement to prevent relative rotation of the first and second valve caps 20,50.

**[0042]** The second valve cap 50 is assembled onto the first valve cap 20 such that the second abutment stop 48 on the second valve cap 50 abuts the first abutment stop 46 on the valve body, as shown in Figure 5B. The ridges provided on the textured interior surface 40 of the valve body 4 correspond with the external ridges 26 on the outer periphery of the cap 20. The predefined adjustment steps provided by the ratchet tooth 38 engaging with the textured surface 40 therefore ensure that the second, or outer, valve cap 50 can be fitted in position with the first and second abutment stops 46,48 in contact without changing the rotational position of the first valve cap 20.

**[0043]** Once assembled as shown in Figure 5B, the first and second valve caps 20,50 are prevented from rotating relative to one another, and the engagement of the first and second abutment stops 46,48 prevents rotation of the second valve cap 50 in the clockwise direction 42. The valve 2 therefore prevents an increase of threshold pressure beyond the desired level, such as 60 cmH<sub>2</sub>O. The engagement of the first and second abutment stops 46,48 does not impede rotation of the first and second valve caps 20,50 in the anticlockwise direction 54, so the threshold pressure of the valve 2 can be adjusted to lower than 60 cmH<sub>2</sub>O if required. Once the valve caps 20,50 are rotated anticlockwise 54 to the end of the screw thread 32, the valve member 10 will still be clear of the valve seat 6, as shown in Figures 1 and 3, so the valve 2 can still be set to a minimum threshold pressure of 0 cmH<sub>2</sub>O if required. The threshold pressure at the fully open position of the valve 2 will thus always be 0 cmH<sub>2</sub>O, regardless of the spring strength selected.

**[0044]** The outer/second valve cap 50 clips over the first valve cap 20 and locks these together so that once pushed down 52 into place during assembly, the second valve cap 50 cannot be readily removed from the first valve cap 20. Figure 6 shows a cross-section of the arrangement. One or more clips 56 are provided around the periphery on the interior surface of the second valve cap 50, and engage underneath the ridges 26 on the outer surface of the first valve cap 20 to secure the caps 20,50 together. The valve member 10 can be seen within the valve body 4 in Figure 6, with the resilient element 8 engaged with the valve seat 6. The coil spring 30 is omitted, and the second abutment stop 48 of the second valve cap 50 is obscured behind the first abutment stop 46 on the valve body 4.

**[0045]** The breathing system of Figure 7 includes a pair of T shaped connectors 58 providing a flow passageway with first and second ends 60,62 and first and second side connectors 64,66. It will be appreciated that a similar arrangement could be provided in a single, more complex, connector piece if desired. The first end 60 is connected to a reservoir bag 68, while the second end 62 is connectable to a patient/user interface device 70, for example a breathing mask. The first side connector 64 is connected to a tube 72, which is in fluid connection with a fresh gas supply, for example an oxygen concentrator or other compressed gas source 74, a ventilator or an anaesthetic/anaesthesia machine.

**[0046]** The inlet 34 of the APL valve 2 of the invention is connected to the second side connector 66 to provide a pressure release valve. In the event that pressure within the system,

for example on exhalation by a user, exceeds the pre-set valve for the APL valve 2, the valve member 10 will open and allow excess gas flow to pass through the valve 10 and out of the outlet 36.

**[0047]** Although described with reference to an APL valve, it should be noted that the design considerations and features described above could also be applied to similar valves which are capable of adjustment during use, for example adjustable Positive End Expiratory Pressure (PEEP) valves etc. It should also be understood that the threshold pressures discussed are included merely by way of example, and that appropriate design and selection of valve components could provide different maximum threshold pressures as required for a particular implementation.

## REFERENCES CITED IN THE DESCRIPTION

### Cited references

This list of references cited by the applicant is for the reader's convenience only. It does not form part of the European patent document. Even though great care has been taken in compiling the references, errors or omissions cannot be excluded and the EPO disclaims all liability in this regard.

### Patent documents cited in the description

- [US20100206310A](#) **[0007]**

**PATENTKRAV**

1. Justerbar ventil (2), der omfatter:
  - et ventillegeme (4), der omfatter et ventilsæde (6);
  - et ventilelement (10), der kan bevæges i forhold til ventilsædet (6);
  - 5 en første ventilhætte (20);
  - en anden ventilhætte (50); og
  - et forspændingselement (30) tilvejebragt mellem den første ventilhætte (20) og ventilelementet (10), således at ventilelementet (10) forspændes væk fra den første ventilhætte (20) ved en forspændingskraft fra forspændingselementet (30);
  - 10 hvor den første ventilhætte (20) kan bevæges inden for et defineret bevægelsesområde i forhold til ventillegemet (4), således at bevægelse af den første ventilhætte (20) i en første retning øger den forspændingskraft, der påføres af forspændingselementet (30);
  - og **kendetegnet ved**, at den anden ventilhætte (50) kan bringes i indgreb med den første ventilhætte (20) ved en flerhed af den første ventilhættes (20) positioner inden for dens
  - 15 definerede bevægelsesområde for at forhindre bevægelse af den første ventilhætte (20) i den første retning udover en valgt position af flerheden af positioner men tillade bevægelse af den første ventilhætte (20) i en anden retning, modsat den første retning, inden for det definerede bevægelsesområde.
- 20 2. Justerbar ventil (2) ifølge krav 1, hvor den anden ventilhætte (50) omfatter et første anlægsstop (48), og ventillegemet (4) omfatter et andet anlægsstop (46), og hvor anlæg af det første og andet anlægsstop (46,48) forhindrer bevægelse af den første ventilhætte (20) i den første retning.
- 25 3. Justerbar ventil (2) ifølge krav 2, hvor det første og andet anlægsstop (46,48) bevæges i kontakt, når den anden ventilhætte (50) bringes i indgreb med den første ventilhætte (20).
4. Justerbar ventil (2) ifølge et hvilket som helst foregående krav, hvor ventillegemet (4) omfatter et skruegevind (32) til at tilvejebringe det definerede bevægelsesområde for den første
- 30 ventilhætte (20).
5. Justerbar ventil (2) ifølge et hvilket som helst foregående krav, hvor den første ventilhætte (20) og/eller anden ventilhætte (50) er konfigureret til at modstå relativ bevægelse

af den anden ventilhætte (50) i forhold til den første ventilhætte (20), når den anden ventilhætte (50) er bragt i indgreb med den første ventilhætte (20).

- 5 **6.** Justerbar ventil (2) ifølge krav 5, hvor den første ventilhætte (20) og anden ventilhætte (50) er dimensioneret til at gå i indgreb med en prespasning.
7. Justerbar ventil (2) ifølge krav 5 eller 6, hvor mindst én af den første ventilhætte (20) og anden ventilhætte (50) omfatter én eller flere indgrebskarakteristika (56) for at modstå frigørelse af den anden ventilhætte (50) fra den første ventilhætte (20).
- 10 **8.** Justerbar ventil (2) ifølge et hvilket som helst af kravene 5 til 7, hvor den første ventilhætte (20) og anden ventilhætte (50) omfatter tilsvarende indgrebskarakteristika (26) for at forhindre rotation af den anden ventilhætte (50) i forhold til den første ventilhætte (20).
- 15 **9.** Justerbar ventil (2) ifølge et hvilket som helst foregående krav, hvor ventillegemet (4) eller den første ventilhætte (20) omfatter en flerhed af indsnit (40) til at definere den første ventilhættes (20) flerhed af positioner.
- 20 **10.** Justerbar ventil (2) ifølge krav 9, hvor flerheden af indsnit (40) tilvejebringes af en tekstureret eller rillet flade på ventillegemet (4).
- 11.** Luftningssystem, der omfatter et friskgasindtag, en første udgang (62), der kan forbindes med en brugergrænseflade (70), og en justerbar ventil (2) ifølge et hvilket som helst foregående krav, hvor den justerbare ventil (2) tilvejebringes ved en anden udgang (66) placeret  
25 mellem friskgasindtaget og den første udgang (62).
- 12.** Fremgangsmåde til indstilling af en justerbar ventil (2) omfattende trinnene med rotation af en gevindindstiller (20) i forhold til et ventilhus (4) for at indstille et ønsket ventilåbningstryk og efterfølgende bringe en låsehætte (50) i indgreb med gevindindstilleren  
30 (20), således at en del af låsehætten (50) ligger an mod en del af ventilhuset (4) for at forhindre rotation af gevindindstilleren i en første retning ud over et punkt svarende til det ønskede ventilåbningstryk men for at begrænse rotation af gevindindstilleren (20) i en anden, modsat, retning.

- 13.** Fremgangsmåde ifølge krav 12, hvor den første retning er en retning med uret og den anden retning er en retning mod uret.
- 14.** Fremgangsmåde ifølge krav 12 eller 13, hvor låsehættens (50) indgreb i gevindindstilleren (20) permanent fastgør låsehættens (50) til gevindindstilleren (20).
- 15.** Fremgangsmåde ifølge et hvilket som helst af kravene 12 til 14, hvor den justerbare ventil (2) er ifølge et hvilket som helst af kravene 1 til 11.

# DRAWINGS

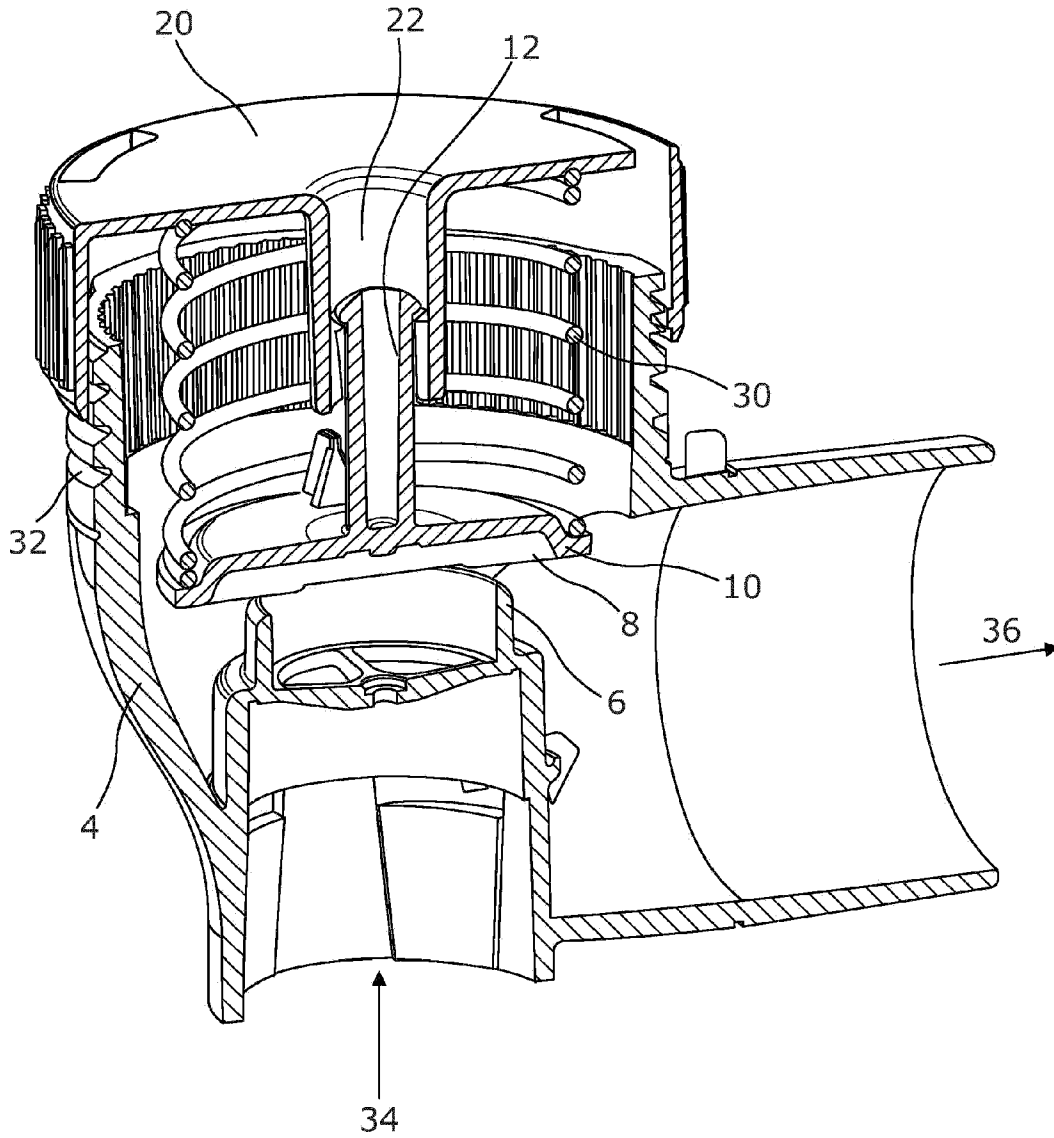

Figure 1

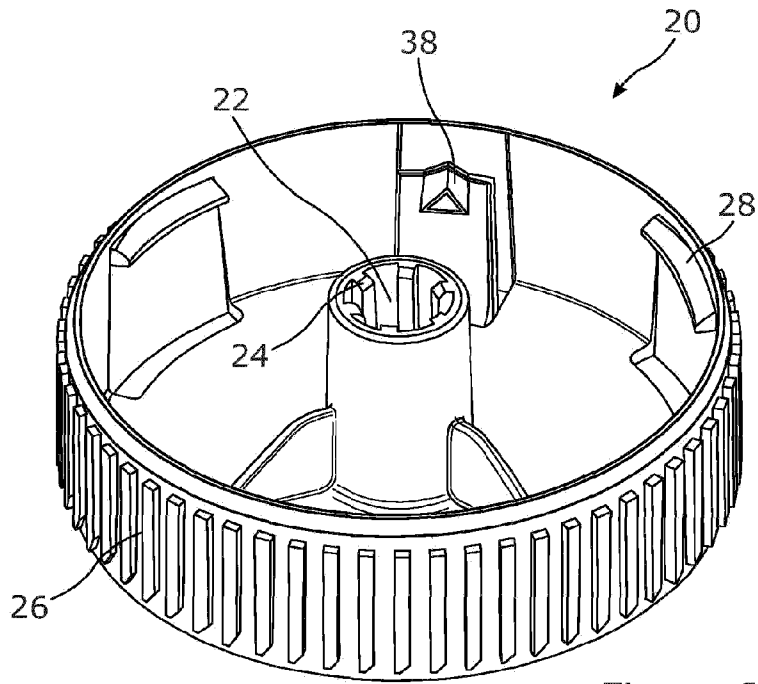

Figure 2

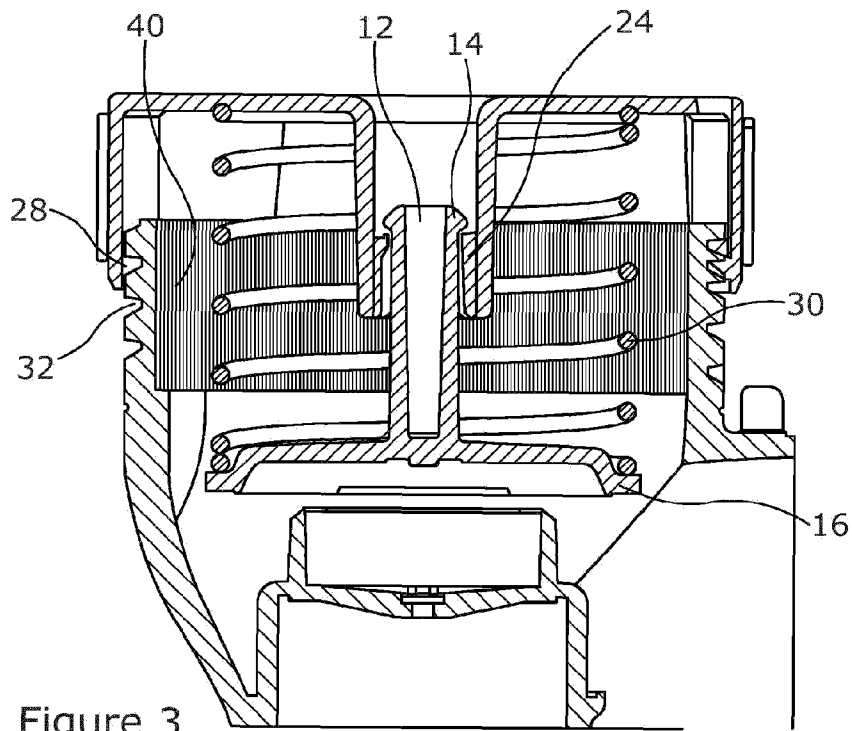

Figure 3

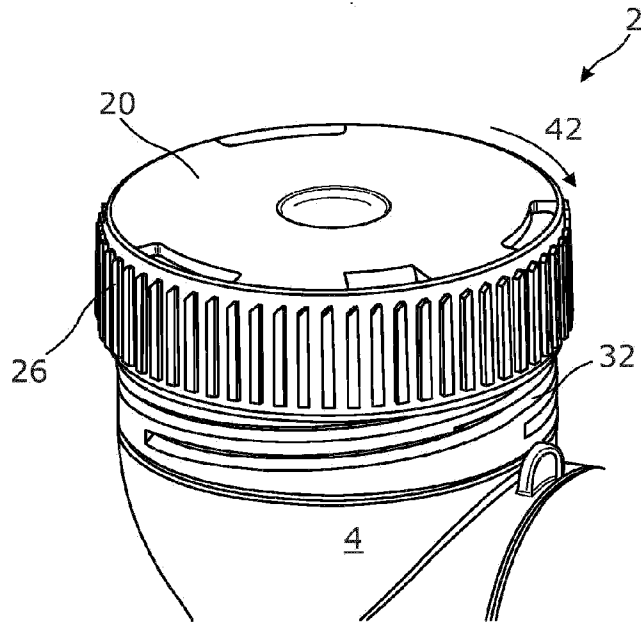

Figure 4A

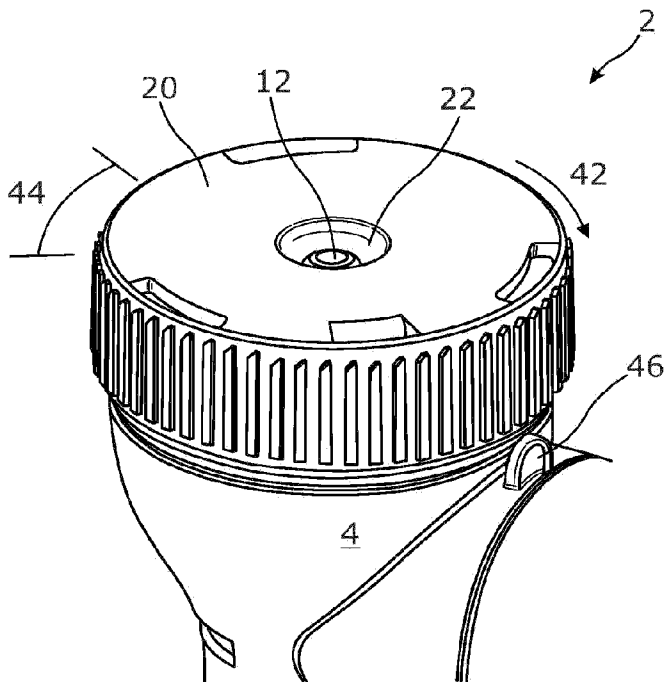

Figure 4B

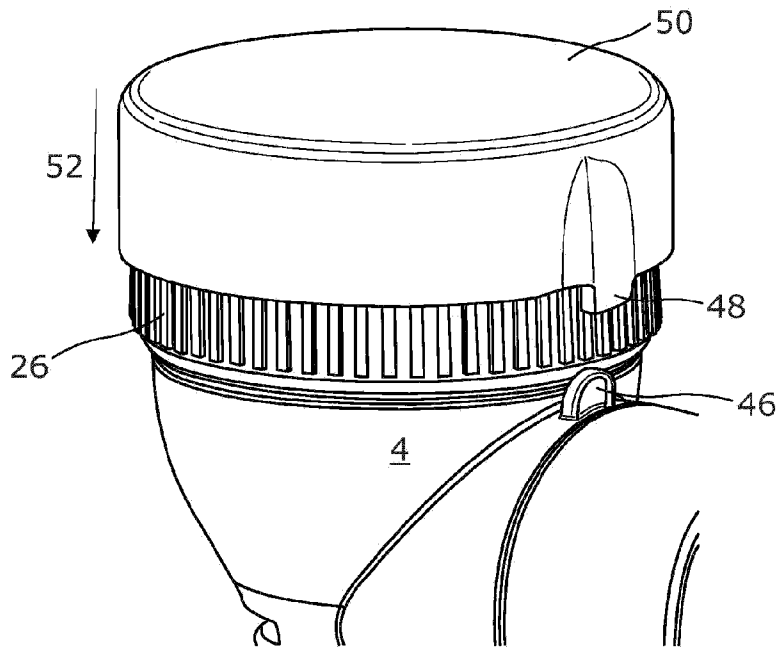

Figure 5A

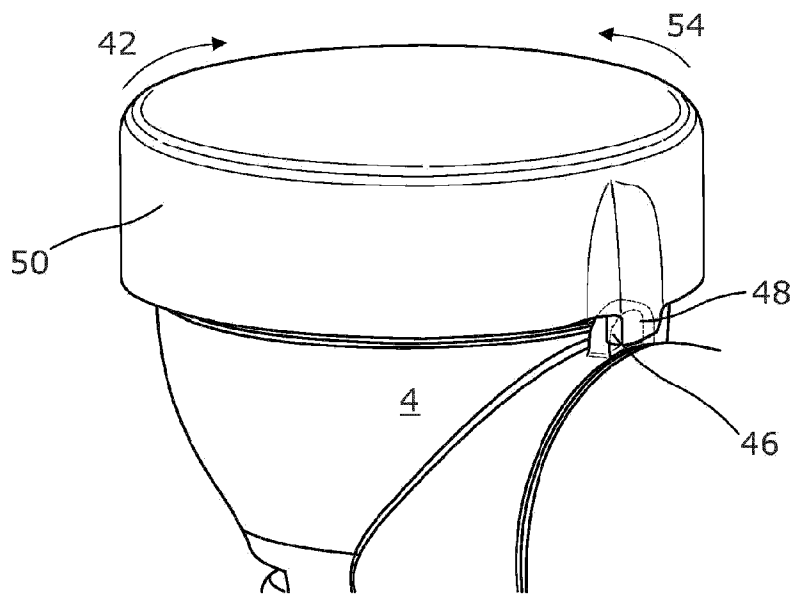

Figure 5B

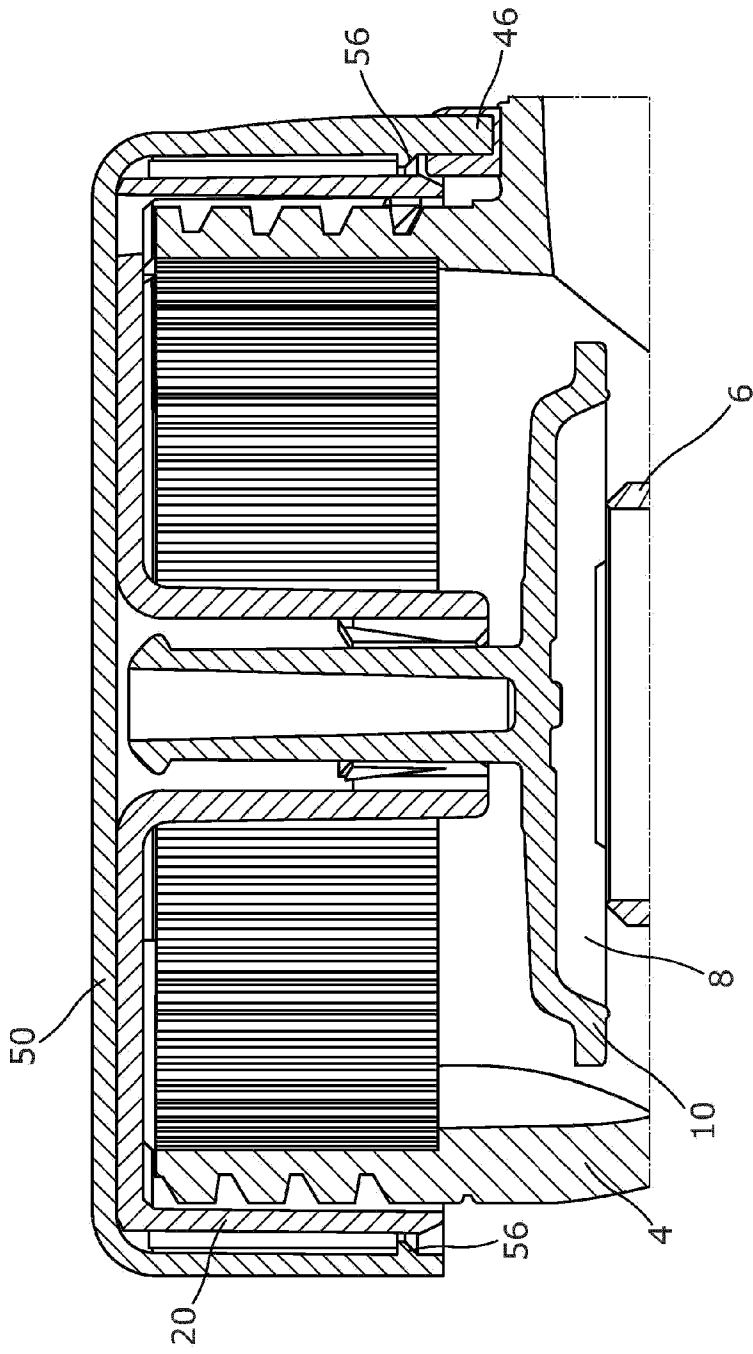

Figure 6

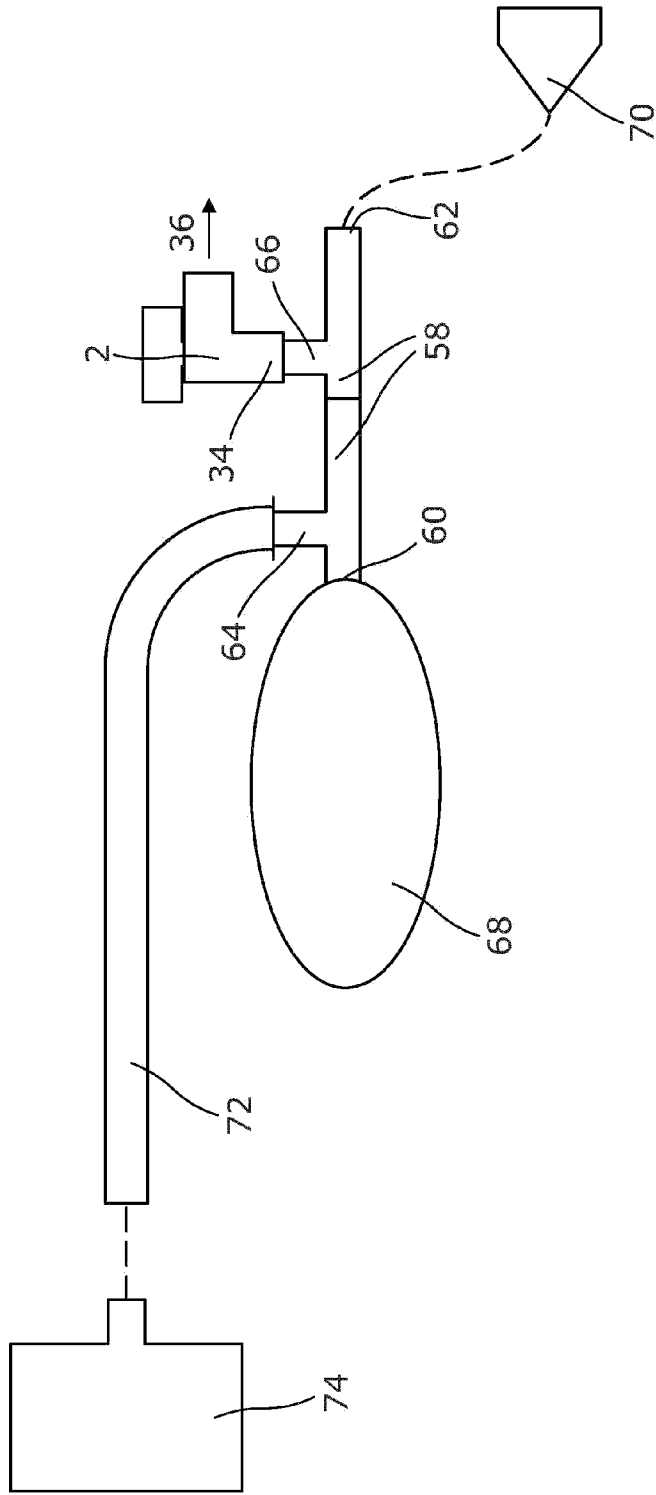

Figure 7