



(43) International Publication Date
25 September 2014 (25.09.2014)

- (51) International Patent Classification:
B65D 55/08 (2006.01) *G09F 3/03* (2006.01)
- (21) International Application Number:
PCT/US2014/024711
- (22) International Filing Date:
12 March 2014 (12.03.2014)
- (25) Filing Language: English
- (26) Publication Language: English
- (30) Priority Data:
61/791,560 15 March 2013 (15.03.2013) US
- (72) Inventors; and
(71) Applicants : **MITTEN, Robert** [US/US]; 10221 Brooke-
moor Lane, Glen Allen, Virginia 23060 (US). **HESSION,
Christopher J.** [US/US]; 9335 Summer Oak Dr, Mechan-
icsville, Virginia 23116 (US). **SIMPSON, Christopher L.**
[US/US]; 401 Hamilton St., Unit G, Richmond, Virginia
23221 (US).
- (74) Agents: **SHIPSIDES, Geoffrey P.** et al.; Fish & Richard-
son P.C., P.O. Box 1022, Minneapolis, Minnesota 55440-
1022 (US).

(81) Designated States (unless otherwise indicated, for every kind of national protection available): AE, AG, AL, AM, AO, AT, AU, AZ, BA, BB, BG, BH, BN, BR, BW, BY, BZ, CA, CH, CL, CN, CO, CR, CU, CZ, DE, DK, DM, DO, DZ, EC, EE, EG, ES, FI, GB, GD, GE, GH, GM, GT, HN, HR, HU, ID, IL, IN, IR, IS, JP, KE, KG, KN, KP, KR, KZ, LA, LC, LK, LR, LS, LT, LU, LY, MA, MD, ME, MG, MK, MN, MW, MX, MY, MZ, NA, NG, NI, NO, NZ, OM, PA, PE, PG, PH, PL, PT, QA, RO, RS, RU, RW, SA, SC, SD, SE, SG, SK, SL, SM, ST, SV, SY, TH, TJ, TM, TN, TR, TT, TZ, UA, UG, US, UZ, VC, VN, ZA, ZM, ZW.

(84) Designated States (unless otherwise indicated, for every kind of regional protection available): ARIPO (BW, GH, GM, KE, LR, LS, MW, MZ, NA, RW, SD, SL, SZ, TZ, UG, ZM, ZW), Eurasian (AM, AZ, BY, KG, KZ, RU, TJ, TM), European (AL, AT, BE, BG, CH, CY, CZ, DE, DK, EE, ES, FI, FR, GB, GR, HR, HU, IE, IS, IT, LT, LU, LV, MC, MK, MT, NL, NO, PL, PT, RO, RS, SE, SI, SK, SM, TR), OAPI (BF, BJ, CF, CG, CI, CM, GA, GN, GQ, GW, KM, ML, MR, NE, SN, TD, TG).

Published:

— with international search report (Art. 21(3))

(54) Title: LABELED CONTAINER

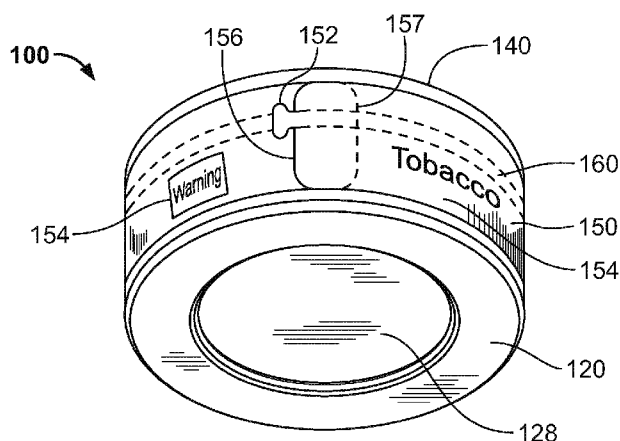

FIG. 1A

(57) Abstract: Articles of manufacture, products, and packaging methods are provided that include a label with a tear strip. A labeled container includes a base, a lid, and a label sealing the base to the lid. The base includes a bottom wall and a base side wall. The lid includes a top wall and a lid skirt. The lid mates with the base to define an interior space. The label has a front face and a rear face. The label includes an outer web including polymer film, paper, or a combination thereof and an inner web of polymer. A tear strip is defined in the inner web by one or more weakened portion, score lines, or cuts in the inner web. The rear face of the label is adhesively bonded to the base side wall and to the lid skirt to form a seal between the base and the lid. The tear strip is positioned between a portion of the label adhesively bonded to the base side wall and a portion of the label adhesively bonded to the lid skirt. The tear strip can be used to open the container.



LABELED CONTAINER

CROSS REFERENCE TO RELATED APPLICATIONS

This application claims the benefit of priority to U.S. Application No. 61/791,560 filed March 15, 2013. The prior application is incorporated herein by reference in its entirety.

TECHNICAL FIELD

This disclosure generally relates to labels having tear strips. In some cases, the labels having tear strips provided herein can be applied to containers containing smokeless tobacco (e.g., pouched smokeless tobacco).

BACKGROUND

Smokeless tobacco is tobacco that is placed in the mouth and not combusted. There are various types of smokeless tobacco including: chewing tobacco, moist smokeless tobacco, snus, and dry snuff. Smokeless tobacco products are often packaged in a cylindrical can having a base and a lid. The base and the lid can be sealed together with a label, which can improve shelf stability and provide tamper evidence. Adult Tobacco Consumers often open a container including smokeless tobacco by using a fingernail, key, knife, or other object to rip the label along the lower edge of the lid.

SUMMARY

Labels having tear strips, method of manufacturing labels having tear strips, containers having labels having tear strips, and packaging techniques are provided herein. A labeled container provided herein can include a base, a lid, and a label sealing the base to the lid. The base can include a bottom wall and a base side wall. The lid can include a top wall and a lid skirt. The lid can mate with the base to define an interior space. A label provided herein can have a front face and a rear face. The label provided herein can include an outer web including polymer film, paper, or a combination thereof and an inner web including polymer. A tear strip is defined by one or more weakened portion, score lines, or cuts in the inner web. The rear face of the label provided herein can be adhesively bonded to the base

side wall and to the lid skirt to form a seal between the base and the lid. The tear strip provided herein can be positioned between a portion of the label adhesive bonded to the base side wall and a portion of the label adhesively bonded to the lid skirt. The tear strip can be used to open the container.

5 A container provided herein can be a container for smokeless tobacco. For example, smokeless tobacco can be deposited in the base of a container provided herein prior to the lid being mated with the base and a label provided herein applied to the container. In some cases, non-tobacco products can be placed in a container provided herein. In some cases, containers provided herein are cylindrical. In some cases, containers provided herein are
10 elliptical, rectangular, or any other suitable shape. In some cases, a bottom wall of a base of a container provided herein can include a truncated cone shape. In some cases, a container provided herein includes polymer, paperboard, metal, or a combination thereof. For example, a base can include molded plastic, paperboard, or tinplate steel. For example, a lid can include molded plastic or tinplate steel. In some cases, the lid and/or base can be
15 embossed or printed with product information. In some cases, the lid and the base can have a snap fit connection. In some cases, an upper surface of the lid can include a sealing ring to form an additional seal.

 Labels provided herein can include any suitable material. In some cases, labels provided herein can include an outer web made of one or more polymer film and/or paper. In
20 some cases, a front face of an outer web of the label provided herein can include printing to decorate the container and/or provide product information. For example, a front face of the label provided herein can include printed characters, symbols, warnings, or other indicia. In some cases, the outer web of a label provided herein is printed with one or more product safety and/or health warnings. An inner web provided herein can include a polymer. A tear
25 strip defined in the inner web can include a polymer. In some cases, the outer web is adhesively bonded to the inner web. In some cases, a label provided herein includes additional webs adhesively bonded between the inner web and the outer web, which can include similar or dissimilar materials. The weakened areas, score lines, or cuts in the inner web defining the tear strip can be applied to the inner web prior to bonding the inner web to
30 the outer web in order to avoid inadvertent cutting of the outer web, which could result in an

improper seal between the lid and the base and compromise shelf stability of certain products.

Labels provided herein can include pull tabs. A pull tab can be formed as part of an outer web provided herein. For example, cuts in an outer web can define a pull tab. In some cases, a pull tab can project past a side edge of the outer web. The pull tabs provided herein can be aligned with the tear strip defined in the inner web. In some cases, an end portion of a tear strip is adhesively bonded to a rear side of a pull tab. In some cases, a tear strip provided herein extends along an entire length of an outer web provided herein.

Labels provided herein can provide a hinge portion. A hinge portion provided herein can be a portion of an outer web member that is not removed by the tear strip when the container is opened using the tear strip. A hinge portion provided herein can, in some cases, be defined by a side edge of the label, a cut in an outer web perpendicular to the tear strip, a portion of the label adhesive bonded to the base side wall, and a portion of the label adhesively bonded to the lid skirt. In some cases, a hinge portion provided herein is covered by an opposite side portion of the label prior to opening the labeled container. Having the hinge portion covered by an opposite side portion of the label can ensure that the container seal is not compromised by a cut in the outer web defining the hinge portion. In some cases, the tear strips provided herein do not extend along the hinge portion. In some cases, a tear strip provided herein is not adhesively bonded to the hinge portion of the web.

In some aspects, methods of making labels are provided. In some cases, a method provided herein can include printing on a front face of a first web including polymer film, paper, or a combination thereof, creating one or more weakened portions, scores, or cuts in a second web that includes a polymer to define a tear strip, bonding the second web defining the tear strip to a rear face of the first web to create a label, and applying a rear face of the label to a container or to a release sheet. Creating the weakened portions, scores, or cuts in the second web prior to connecting the second web to the first web can reduce the risk of the first web being compromised in a way that would threaten shelf stability. In some cases, the printing of the first web provided herein can be done before, after, or concurrent with creating the one or more weakened portions, scores, or cuts in the second web, bonding a second web to the rear face of the first web, or applying the label to a container or release sheet.

While the labels, containers, and methods provided herein are generally described in reference to smokeless tobacco, it should be understood that these labels, containers, and methods can also be used with other packaged products. For example, a container with a label having a tear strip provided herein can be used to package non-tobacco or “herbal” compositions, which may be used as an alternative to smokeless tobacco compositions. Non-tobacco products may include a number of different primary ingredients, including but not limited to, tea leaves, red clover, coconut flakes, mint leaves, ginseng, apple, corn silk, grape leaf, and basil leaf. In some cases, a non-tobacco product packaged in a container provided herein includes a non-tobacco material within a pouch. In some cases, a non-tobacco product can include one or more tobacco extracts. In some cases, tobacco extracts added to a packaged product can include nicotine. In some cases, a non-tobacco smokeless product packaged in a container provided herein can include an extract of tobacco including two or more tobacco organoleptic components.

Labels provided herein can include one or more of the following advantages. In some cases, a label provided herein can permit a sealed container including a label provided herein to be easily opened, without a need to use a fingernail, key, knife, or other object to cut the label or peel the label off. In some cases, a label provided herein can provide tamper evidence by indicating when a label has been opened. In some cases, a label provided herein provides a method of opening a smokeless tobacco container that is familiar to adult tobacco consumers. In some cases, a label provided herein can open to leave a hinge portion of the label, so that a lid can remain with the base. In some cases, labels provided herein can provide these advantages without compromising product shelf stability or product freshness. In some cases, labels provided herein can be used with existing labeling equipment (e.g., labeling equipment standard for labeling smokeless tobacco containers).

Unless otherwise defined, all technical and scientific terms used herein have the same meaning as commonly understood by one of ordinary skill in the art to which the methods and compositions of matter belong. Although methods and materials similar or equivalent to those described herein can be used in the practice or testing of the methods and compositions of matter, suitable methods and materials are described below. In addition, the materials, methods, and examples are illustrative only and not intended to be limiting. All publications,

patent applications, patents, and other references mentioned herein are incorporated by reference in their entirety.

DESCRIPTION OF DRAWINGS

Figure 1A is a perspective view of a labeled container provided herein.

5 Figure 1B is a perspective view of an unlabeled container in an open configuration and including a smokeless tobacco product.

Figure 1C depicts an adult tobacco consumer using a pull tab to open the container.

Figure 1D depicts an adult tobacco consumer removing a pinch of smokeless tobacco from the container.

10 Figure 1E depicts an adult tobacco consumer closing the container after removing a pinch of smokeless tobacco.

Figure 2A is a front view of a first arrangement of a label provided herein.

Figure 2B is a detailed view of the pull tab of the label of Figure 2A

Figure 2C is a rear view of the label of Figure 2A.

15 Figure 2D is a front view of label stock including a plurality of labels having the arrangement of the label of Figure 2A.

Figure 2E is a diagram showing the portions of the label of Figure 2A that will be visible after a container including the label of Figure 2A is opened.

20 Figures 3A-3E depict a second arrangement of a label provided herein, label stock including a plurality of such labels, and the portions that will be visible after a container including the label is opened.

Figures 4A-4E depict a third arrangement of a label provided herein, label stock including a plurality of such labels, and the portions that will be visible after a container including the label is opened.

25 Figures 5A and 5B depict the front and back of a fourth arrangement of a label provided herein.

Figures 6A and 6B depict the front and back of a fifth arrangement of a label provided herein.

30 Figures 7A and 7B depict the front and back of a sixth arrangement of a label provided herein.

Figures 8A and 8B depict the front and back of a seventh arrangement of a label provided herein.

Like reference symbols in the various drawings indicate like elements.

DETAILED DESCRIPTION

5 Labels having tear strips, method of manufacturing labels having tear strips, products including containers having labels having tear strips, and packaging techniques for tobacco and non-tobacco products are provided herein.

 Referring to FIGS. 1A-E, some embodiments of a tobacco container 100 can be used to maintain or enhance freshness and other product qualities of tobacco products (e.g.,
10 chewing tobacco, moist snuff tobacco (loose, pouch, or other articulations), dry snuff tobacco, or other smokeless tobacco products for oral consumption)) contained therein. Such qualities may relate to, without limitation, texture, flavor, color, aroma, mouth feel, taste, ease of use, and combinations thereof. The tobacco container 100 can include a container base 120, a lid 140, and a label 150 including a pull tab 152. The label can seal the lid 140 to
15 the container base 120 so as to improve product freshness during shelf life. When sealed, the label 150 may serve as a moisture barrier that limits the egress of the moisture from the container base 120 (or the ingress of the moisture into the container base 120). In some circumstances, label 150 may provide a non-hermetic seal that provides a limited amount of gas exchange with the ambient air (e.g., to permit venting of evolved gases or the like). An
20 inner web defining a tear strip 160 (identified by dotted lines) is adhesively bonded to a rear side of an outer web to guide the tearing of the label 150 when an adult tobacco consumer opens the container 100.

 As shown in FIGS. 1B, 1D, and 1E, the container base 120 and lid 140 are matable with one another so that the container 100 can be closed and thereby retain tobacco or other
25 products therein (refer, for example, to the moist snuff tobacco 110 illustrated in FIG. 1B and FIG. 1D). In this embodiment, the container base 120 has a generally cylindrical shape and includes a bottom wall and a cylindrical base side wall that at least partially defines an interior space 121. The container base 120 may comprise a material such as a polymer (e.g., polypropylene or the like), fiberboard, or metallic material that is suitable for storing tobacco
30 products having one or more flavorants or volatile agents. In this embodiment, the container

base 120 comprises a moldable polymer material. The container 100 can be arranged in a closed condition so that the container base 120 has a snap-fit engagement with the lid 140. Alternatively, the container base 120 can be configured to have a slide-lock engagement with the lid 140.

5 The lid 140 may include a metallic material (e.g., aluminum, tin, stainless steel, or the like). Alternatively, the lid 140 can be formed from a moldable polymer material such as polypropylene or the like. The lid 140 includes a lid wall 141 and a lid skirt 144 that extends from the circumference of the lid wall 141. In this embodiment, the lid skirt 144 includes a second bead 145 that mates with the container base 120 to releasably retain the lid 140 to the
10 container base 120, thereby enclosing the snuff tobacco 110 or other tobacco products in the closed container 100. In some embodiments, the lid 140 can include a gasket 130, which can also assist in sealing the tobacco product packaging device 100.

 As shown in FIG. 1A, a rear face of label 150 can be adhesively bonded to surfaces of both the lid 140 and the container base 120 to seal the container. A front face of the label
15 150 can include printing 154, which can include a host of different decorative or informative alphanumeric characters, symbols, patterns, designs, or figures. In some cases, a container provided herein can include a health and/or safety warning. A pull tab 152 is provided as part of the label 150 to permit a user to break the seal and separate the lid 140 from the container base 120. Shown with dotted lines in FIG. 1A, a tear strip is defined by an inner
20 web of the label, extended along the length of the label and around at least part of the periphery of the container base 120 and the lid 140. Opposite ends 156 and 157 of label 150 can overlap when placed on a product package. As shown in FIG. 1C, an adult tobacco consumer can grasp pull tab 152 and use tear strip 160 to split the label 150 along the
25 interface between lid skirt 144 of lid 140 and the cylindrical base side wall of the container base 120, which results in the label being split into label top portion 150b and label bottom portion 150a. After obtaining some of the tobacco (FIG. 1D), the container 100 can be closed again (FIG. 1E). As shown in FIG. 1E, label top portion 150b and label bottom portion 150a can remain on the product packaging and continue to display information (e.g., product health or safety warnings). In some cases, select information on label 150 can be
30 arranged on label 150 so that it does not become obscured by the removal of label material resulting from the opening of the product package using pull tab 150.

Label 150 can include an outer web including polymer film, paper, or a combination thereof that seals the exterior interface between the lid 140 and the container base 120. For example, a web including polymer film can impede the ingress or egress of moisture there through, thereby preserving the product freshness of the snuff tobacco 110 or other tobacco products contained in the container 100. In some cases, an outer web provided herein can be free of cuts, scores, or weakened portions. For example, an inner web defining a tear strip can be scored or cut prior to being adhesively bonded to the outer web in order to reduce a likelihood of the outer web being compromised. In some cases, an outer web provided herein can include weakened portions, scores, and cuts in portions of the label that overlap. Specific structures of labels provided herein are discussed below in reference to Figures 2A-8B.

Still referring to FIGS. 1A-E, the container base 120 includes a connection rim 122 that includes a first bead 125 (such as a locking ring depicted in FIG. 1B) to mate with the second bead 145 of the lid 140. The connection rim 122 can be integrally formed as part of the cylindrical base side wall of the container base 120. As shown in FIG. 1B, the gasket 130 can be affixed to an inner lid surface 142 so that the gasket 130 is positioned between the lid wall 141 and the connection rim 122 when the lid 140 mates with the container base 120. As such, the metallic lid 140 of this embodiment can be press-fit with the polymeric container base 120 so that the second bead 145 mates with the first bead 125 of the container base 120, thereby urging the lid wall 141 toward the container base 120. Because the lid wall 141 is urged toward the container base 120, the gasket 130 can be at least partially compressed between the metallic lid 140 and the polymeric container base 120 when the package device is in the closed condition. In this embodiment, the gasket 130 includes a ring-shaped structure arranged on the inner lid surface 142 so as to abut against a connection rim 122 of the container base 120. The gasket 130 comprises a generally resilient material that is affixed to the inner lid surface 142. For example, in this embodiment, the gasket 130 may comprise a plastisol composition that is formed into a ring of film along the inner lid surface 142. In alternative embodiments, the gasket 130 may comprise another material, such as a urethane material, an epoxy material, or a wax material.

In the particular embodiment shown in FIG. 1C, the tobacco container 100 can include a label 150 that secures the container base 120 and lid 140 together during the

product shelf life. The label 150 can include a tear strip 160 that extends along the circumference of the container 100 so that a consumer can pull upon the pull tab 152 to facilitate opening of the container 100 at a region near the interface of the container base 120 and the lid skirt 144. Although FIG. 1C depicts the tear strip 160 as being visible, a tear strip
5 160 provided herein can be hidden by the outer web of the label.

As shown in FIG. 1D, the consumer can separate the lid 140 from the container base 120 so that the tobacco container 100 is in the opened condition. With the lid 140 removed, the consumer can access the tobacco product 110 stored in the container base 120. For example, in this embodiment the container base 120 is used to store a moist snuff tobacco
10 110, and the consumer can pinch a portion 112 of the snuff tobacco for personal usage while the remaining portion of the snuff tobacco 110 is retained in the container base 120.

As shown in FIG. 1E, after the consumer obtains a portion of the tobacco product 110, the consumer can return the tobacco container 100 to the closed condition. For example, the user can press the lid 140 over the connection rim 122 of the container base 120 to reengage the lid 140 with the container base 120 and to thereby enclose the remaining
15 tobacco product 110 in the container 100. As shown in FIG. 1E, label portions 150a and 150b remain on the container 100.

Although the particular embodiment depicted in FIGS. 1A-E illustrate the tobacco product in the container 100 as being a moist snuff tobacco product, it should be understood
20 from the description herein that any one of a number of tobacco products and non-tobacco products can be retained in the container 100. For example, the tobacco product arranged in the container 100 may comprise chewing tobacco, dry snuff tobacco, moist snuff tobacco (loose, pouch, or other articulations), or another smokeless tobacco product. The tobacco product can include tobacco that is whole, shredded, cut, cured, aged, fermented, pasteurized,
25 pouched, or otherwise processed. In some embodiments, the tobacco contained in the container 100 may include portions of leaves, flowers, roots, stems, or extracts thereof of any member of the genus *Nicotiana*. Further, the tobacco may include an extract of tobacco that provides additional tobacco constituents (e.g., flavors, aromas, alkaloids, or the like). In some embodiments described herein, the tobacco product may include one or more
30 components such as flavor extracts, flavor masking agents, bitterness receptor site blockers, receptor site enhancers, sweeteners, and additives such as chlorophyll, minerals, botanicals,

or breath-freshening agents. In some cases, the container 100 can include non-tobacco products. A container with a label having a tear strip provided herein can be used to package non-tobacco or “herbal” compositions, which may be used as an alternative to smokeless tobacco compositions. Non-tobacco products may include a number of different primary ingredients, including but not limited to, tea leaves, red clover, coconut flakes, mint leaves, ginseng, apple, corn silk, grape leaf, and basil leaf. In some cases, a non-tobacco product packaged in a container provided herein includes a non-tobacco material within a pouch. In some cases, a non-tobacco product can include one or more tobacco extracts. In some cases, tobacco extracts added to a packaged product can include nicotine. In some cases, a non-tobacco smokeless product packaged in a container provided herein can include an extract of tobacco including two or more tobacco organoleptic components.

FIGS. 2A-2E depict a label 250 having a first arrangement. FIG. 2A is a front view of label 250. As shown, an outer web 251 of polymer film, paper, or a combination thereof has a rectangular shape, including a first side edge 256 and a second side edge 257. Alphanumeric characters, symbols, patterns, designs, or figures 254 can be printed on outer web 251. A pull tab 252 is shown in FIG. 2A and shown in further detail in FIG. 2B. As shown, pull tab 252 can be a part of the outer web 251. As shown, the pull tab 252 projects past side edge 256. In some cases, cuts 253a and 253b can be made in the web 251 to define pull tab 252 and to provide for tearing initiation of outer web 251 at the cuts 253a and 253b. Opposite sides of the label can overlap when applied to a container. For example, a portion of the front surface of outer web 251 can include an unvarnished surface 258, which will be adhered to a rear surface of the opposite end of label 250 when the label 250 is applied to a container.

FIG. 2C depicts a rear view of label 250 having an inner web 261 adhesively bonded to a rear side of outer web 251. The inner web 261 can define a tear strip 260 between portions 262 and 264 of the inner web by including a series of weakened portions, scores, and/or cuts 266 or 268. Weakened portions, scores, and/or cuts 266 or 268 can be applied to the inner web 261 before the inner web 261 is applied to outer web 251 in order to ensure that the integrity of the outer web is not compromised. Weakened portions, cuts, or scores in the outer web 251 can compromise the seal between the lid and the container base and thus compromise the shelf life of a product. Moreover, weakened portions, cuts, or scores in the

outer web 251 can alter the aesthetics of the label 250. Adhesive can be applied to portions 262 and 264 for application of the label to a container or to a release strip. FIG. 2D depicts a plurality of labels 250 applied to a release strip 280, which can be rolled up and used as a continuous supply 200 of labels in a standard labeling machine for labeling containers, such as typical smokeless tobacco containers.

FIG. 2E is a diagram showing the portions of the label of FIGS. 2A-2D that will be present and visible after a container including such a label is opened. As shown, the label is split into two parts 250a and 250b with missing section 270 there between. In some cases, product information, health warnings, safety warnings, and other information is positioned on the label such that it is not removed by the tear strip when the container is opened.

Figures 3A-3E depict a second arrangement of a label provided herein. FIG. 3A is a front view of label 350. As shown, an outer web 351 of polymer film, paper, or a combination thereof has a rectangular shape, including a first side edge 356 and a second side edge 357. Alphanumeric characters, symbols, patterns, designs, or figures 354 can be printed on outer web 351. A pull tab 352 is shown in FIG 3A and shown in further detail in FIG. 3B. As shown, pull tab 352 can be a part of the outer web 351. As shown, the pull tab 352 project past side edge 356. In some cases, cuts 353a and 353b can be made in the outer web 351 to define pull tab 352 and to provide for tearing initiation of outer web 351 at the cuts 353a and 353b. Opposite sides of the label can overlap when applied to a container. For example, a portion of the front surface of outer web 351 can include an unvarnished surface 358, which will be adhered to a rear surface of the opposite end of label 350 when the label 350 is applied to a container.

FIG. 3C depicts a rear view of label 350 having an inner web 361 adhesively bonded to a rear side of outer web 351. The inner web 361 can define a tear strip 360 between portions 362 and 364 of the inner web by including a series of weakened portions, scores, and/or cuts 366 or 368. Weakened portions, scores, and/or cuts 366 or 368 can be applied to the inner web 361 before the inner web 361 is applied to outer web 351 in order to ensure that the integrity of the outer web is not compromised. Weakened portions, cuts, or scores in the outer web 351 can compromise the seal between the lid and the container base and thus compromise the shelf life of a product. Moreover, weakened portions, cuts, or scores in the outer web 351 can alter the aesthetics of the label 350. Adhesive can be applied to portions

362 and 364 for application of the label to a container or to a release strip. FIG. 3D depicts a plurality of labels 350 applied to a release strip 380, which can be rolled up and used as a continuous supply 300 of labels in a standard labeling machine for labeling containers, such as typical smokeless tobacco containers.

5 FIG. 3E is a diagram showing the portions of the label of FIGS. 3A-3D that will be present and visible after a container including such a label is opened. As shown, the label is split into two parts 350a and 350b with missing section 370 there between. In some cases, product information, health warnings, safety warnings, and other information is positioned on the label such that it is not removed by the tear strip when the container is opened.

10 Figures 4A-4E depict a third arrangement of a label provided herein, label stock including a plurality of such labels, and the portions that will be visible after a container including the label is opened. FIG. 4A is a front view of label 450. As shown, an outer web 451 of polymer film, paper, or a combination thereof has a rectangular shape, including a first side edge 456 and a second side edge 457. Alphanumeric characters, symbols, patterns, designs, or figures 454 can be printed on outer web 451. A pull tab 452 is shown in FIG 4A
15 and shown in further detail in FIG. 4B. As shown, pull tab 452 can be a part of the outer web 451. As shown, the pull tab 452 project past side edge 456. In some cases, cuts 453a and 453b can be made in the outer web 451 to define pull tab 452 and to provide for tearing initiation of outer web 451 at the cuts 453a and 453b. Opposite sides of the label can overlap
20 when applied to a container. For example, a portion of the front surface of outer web 451 can include an unvarnished surface 458, which will be adhered to a rear surface of the opposite end of label 450 when the label 450 is applied to a container.

FIG. 4C depicts a rear view of label 450 having an inner web 461 adhesively bonded to a rear side of outer web 451. The inner web 461 can define a tear strip 460 between
25 portions 462 and 464 of the inner web by including a series of weakened portions, scores, and/or cuts 466 or 468. Weakened portions, scores, and/or cuts 466 or 468 can be applied to the inner web 461 before the inner web 461 is applied to outer web 451 in order to ensure that the integrity of the outer web is not compromised. Weakened portions, cuts, or scores in the outer web 451 can compromise the seal between the lid and the container base and thus
30 compromise the shelf life of a product. Moreover, weakened portions, cuts, or scores in the outer web 451 can alter the aesthetics of the label 450. Adhesive can be applied to portions

462 and 464 for application of the label to a container or to a release strip. FIG. 4D depicts a plurality of labels 450 applied to a release strip 480, which can be rolled up and used as a continuous supply 400 of labels in a standard labeling machine for labeling containers, such as typical smokeless tobacco containers.

5 FIG. 4E is a diagram showing the portions of the label of FIGS. 4A-4D that will be present and visible after a container including such a label is opened. As shown, the label is split into two parts 450a and 450b with missing section 470 there between. In some cases, product information, health warnings, safety warnings, and other information is positioned on the label such that it is not removed by the tear strip when the container is opened.

10 Figures 5A and 5B depict the front and back of a fourth arrangement of a label 550 provided herein. As shown, an outer web 551 of polymer film, paper, or a combination thereof has a rectangular shape, including a first side edge 556 and a second side edge 557. Alphanumeric characters, symbols, patterns, designs, or figures can be printed on outer web 551. Pull tabs 552a and 552b are shown in FIG 5A and FIG. 5B. As shown, pull tabs 552a
15 and 552b occur in the section of the overlap, with one of them accessible regardless of which side is placed on top. Pull tabs 552a and 552b can be defined by cuts in the outer web 551.

FIG. 5B depicts a rear view of label 550 having an inner web 561 adhesively bonded to a rear side of outer web 551. The inner web 561 can define a tear strip 560 between portions 562 and 564 of the inner web by including a series of weakened portions, scores,
20 and/or cuts 566 or 568. Weakened portions, scores, and/or cuts 566 or 568 can be applied to the inner web 561 before the inner web 561 is applied to outer web 551 in order to ensure that the integrity of the outer web is not compromised. Weakened portions, cuts, or scores in the outer web 551 can compromise the seal between the lid and the container base and thus compromise the shelf life of a product. Moreover, weakened portions, cuts, or scores in the
25 outer web 551 can alter the aesthetics of the label 550. Adhesive can be applied to portions 562 and 564 for application of the label to a container or to a release strip.

Figures 6A and 6B depict the front and back of a fifth arrangement of a label provided herein. As shown, an outer web 651 of polymer film, paper, or a combination thereof has a rectangular shape, including a first side edge 656 and a second side edge 657. Alphanumeric
30 characters, symbols, patterns, designs, or figures can be printed on outer web 651. A pull tab 652 is shown in FIG 6A. As shown, pull tab 652 is formed by a cut in the outer web 651 in a

section of the outer web 651 that overlaps an opposite end of the label. As shown in FIG. 6B, the inner web 661 includes a corresponding cut 665 to defined the beginning of a tear strip 660.

FIG. 6B depicts a rear view of label 650 having an inner web 661 adhesively bonded
5 to a rear side of outer web 651. The inner web 661 can define a tear strip 660 between portions 662 and 664 of the inner web by including a series of weakened portions, scores, and/or cuts 665, 666, and 668. Cut 665 can define the start of the tear strip and be positioned to have the start of the tear strip be adjacent to the pull tab 652 when the inner web 661 and outer web 651 are adhesively bonded together to make the label 650. Weakened portions,
10 scores, and/or cuts 666 or 668 can be applied to the inner web 661 before the inner web 661 is applied to outer web 651 in order to ensure that the integrity of the outer web is not compromised. Weakened portions, cuts, or scores in the outer web 651 can compromise the seal between the lid and the container base and thus compromise the shelf life of a product. Moreover, weakened portions, cuts, or scores in the outer web 651 can alter the aesthetics of
15 the label 650. Adhesive can be applied to portions 662 and 664 for application of the label to a container or to a release strip.

Figures 7A and 7B depict the front and back of a sixth arrangement of a label provided herein. As shown, an outer web 751 of polymer film, paper, or a combination thereof has a rectangular shape, including a first side edge 756 and a second side edge 757.
20 Alphanumeric characters, symbols, patterns, designs, or figures 754 can be printed on outer web 751. A pull tab 752 projects past side edge 756. A cut 753 can be made in outer web 751 to define a hinge portion 758, which continues to connect the upper and lower portions of the label after the container is opened by using the tear strip 760. Cut 753 can ensure that pulling on the tear strip 760 does not tear the hinge portion 758 of the outer web 751 past the
25 cut 753. As shown in FIG. 7B, cut 753 can extend through both the inner and outer webs. Cut 753 can be positioned in a portion of the label 750 that is overlapped when the label 750 is applied to a container so that cut 753 is covered by the opposite side of the label 750 and does not compromise the seal of a container. Cut 753 can be made after the inner web 761 is adhered to outer web 751 to form the label 750. In some cases the inner and outer webs can
30 be separately cut to form cut 753.

FIG. 7B depicts a rear view of label 750 having an inner web 761 adhesively bonded to a rear side of outer web 751. The inner web 761 can define a tear strip 760 between portions 762 and 764 of the inner web by including a series of weakened portions, scores, and/or cuts 753, 766, and 768. Cut 753 can define the end of the tear strip and be positioned to have the end of the tear strip abut a hinge portion 758 of the label 750 when the inner web 761 and outer web 751 are adhesively bonded together to make the label 750. Weakened portions, scores, and/or cuts 766 or 768 can be applied to the inner web 761 before the inner web 761 is applied to outer web 751 in order to ensure that the integrity of the outer web is not compromised. Weakened portions, cuts, or scores in the outer web 751 can compromise the seal between the lid and the container base and thus compromise the shelf life of a product. Moreover, weakened portions, cuts, or scores in the outer web 751 can alter the aesthetics of the label 750. Adhesive can be applied to portions 762 and 764 for application of the label to a container or to a release strip.

Figures 8A and 8B depict the front and back of a seventh arrangement of a label provided herein. As shown, an outer web 851 of polymer film, paper, or a combination thereof has a rectangular shape, including a first side edge 856 and a second side edge 857. Alphanumeric characters, symbols, patterns, designs, or figures can be printed on outer web 851. A pull tab 852 projects past side edge 856. A cut 853 can be made in outer web 851 to define a hinge portion 858, which continues to connect the upper and lower portions of the label after the container is opened by using the tear strip 860. Cut 853 can ensure that pulling on the tear strip 860 does not tear the hinge portion 858 of the outer web 851 past the cut 853. As shown in FIG. 8B, cut 853 can align with an end 863 of the tear strip. Cut 853 can be positioned in a portion of the label 850 that is overlapped when the label 850 is applied to a container so that cut 853 is covered by the opposite side of the label 850 and does not compromise the seal of a container. Cut 853 can be made before or after the inner web 861 is adhered to outer web 851 to form the label 850.

FIG. 8B depicts a rear view of label 850 having an inner web 861 adhesively bonded to a rear side of outer web 851. The inner web 861 can define a tear strip 860 between portions 862 and 864 of the inner web by including a series of weakened portions, scores, and/or cuts 866 and 868. An end 863 of the tear strip can abut a hinge portion 858 of the label 850 when the inner web 861 and outer web 851 are adhesively bonded together to make

the label 850. Weakened portions, scores, and/or cuts 866 or 868 can be applied to the inner web 861 before the inner web 861 is applied to outer web 851 in order to ensure that the integrity of the outer web is not compromised. Weakened portions, cuts, or scores in the outer web 851 can compromise the seal between the lid and the container base and thus
5 compromise the shelf life of a product. Moreover, weakened portions, cuts, or scores in the outer web 851 can alter the aesthetics of the label 850. Adhesive can be applied to portions 862 and 864 for application of the label to a container or to a release strip.

It is to be understood that, while the invention has been described herein in conjunction with a number of different aspects, the foregoing description of the various
10 aspects is intended to illustrate and not limit the scope of the invention, which is defined by the scope of the appended claims. Other aspects, advantages, and modifications are within the scope of the following claims.

Disclosed are methods and compositions that can be used for, can be used in conjunction with, can be used in preparation for, or are products of the disclosed methods and
15 compositions. These and other materials are disclosed herein, and it is understood that combinations, subsets, interactions, groups, etc. of these methods and compositions are disclosed. That is, while specific reference to each various individual and collective combinations and permutations of these compositions and methods may not be explicitly disclosed, each is specifically contemplated and described herein. For example, if a
20 particular composition of matter or a particular method is disclosed and discussed and a number of compositions or methods are discussed, each and every combination and permutation of the compositions and the methods are specifically contemplated unless specifically indicated to the contrary. Likewise, any subset or combination of these is also specifically contemplated and disclosed.

WHAT IS CLAIMED IS:

- 5 1. A labeled container defining an interior space, the container comprising:
 a base comprising a bottom wall and a base side wall;
 a lid comprising a top wall and a lid skirt, the lid mating with the base to
define an interior space; and
 a label having a front face and a rear face, the label comprising an outer web
comprising a polymer film, paper, or a combination thereof and an inner web
10 comprising polymer, the inner web comprising a tear strip being defined by one or
more weakened portion, score lines, or cuts in the inner web, the rear face of the label
being adhesively bonded to the base side wall and to the lid skirt to form a seal
between the base and the lid, the tear strip being positioned between a portion of the
label adhesive bonded to the base side wall and a portion of the label adhesively
15 bonded to the lid skirt.
2. The container of claim 1, wherein smokeless tobacco is in the interior space.
3. The container of claim 1, wherein non-tobacco product is in the interior space.
- 20 4. The container of claim 1, wherein a bottom wall includes truncated cone shape.
5. The container of claim 1, wherein the base or the lid comprise polymer,
paperboard, metal, or a combination thereof.
- 25 6. The container of claim 1, wherein the outer web defines a pull tab aligned with at
least a portion of the tear strip.
7. The container of claim 6, wherein the pull tab protrudes from a side edge of the
label.

8. The container of claim 6, wherein the pull tab is defined by one or more cuts in the outer web.

5 9. The container of claim 1, wherein the tear strip extends along an entire length of outer the outer web.

10. The container of claim 1, wherein the label is designed to leave a hinge portion of the label after the container is opened by using the tear strip.

10 11. The container of claim 10, wherein the hinge portion is defined by a side edge of the label, a cut in the outer web perpendicular to the tear strip, the portion of the label adhesive bonded to the base side wall, and the portion of the label adhesively bonded to the lid skirt.

15 12. The container of claim 11, wherein the hinge portion of the label is covered by an opposite side portion of the label prior to opening the labeled container.

20 13. The container of claim 11, wherein the tear strip does extend past the cut in the outer web.

14. The container of claim 10, wherein the tear strip does not extend along the hinge portion.

25 15. The container of claim 10, wherein the inner web is adhesively bonded to a rear face of the web.

16. The container of claim 15, wherein a rear face of the inner web is adhesively bonded to the lid skirt, the base side wall, or a combination thereof.

30 17. The container of claim 10, wherein the tear strip is not adhesively bonded to the hinge portion of the outer web.

18. The container of claim 1, wherein a front face of the outer web includes printed characters, symbols, warnings, or other indicia.

5 19. The container of claim 1, wherein the label hermetically seals the interior space of the container.

20. A method of making one or more labels comprising:
printing on a front face of a first web comprising a polymer film, paper, or a
10 combination thereof;
applying adhesive to a rear face of the web;
bonding a second web a rear face of the first web to create a label, wherein the second web defines a tear strip with one or more weakened portion, score lines, or cuts in the second web; and
15 applying a rear face of the label to a container or to a release sheet.

21. The method of claim 20, wherein the rear face of the label is bonded to a container including a base and a lid, wherein the rear face of the label is bonded to a portion of the base and a portion of the lid such that the container is sealed with the label, wherein
20 the tear strip is positioned between the portion of the label adhesive bonded to the base and the portion of the label adhesively bonded to the lid skirt.

22. The method of claim 21, wherein the container is filled with smokeless tobacco prior to applying the label to the container.
25

23. The method of claim 20, where multiple labels are applied to a release sheet.

24. The method of claim 21, further comprising: establishing a hinge portion by cutting through said first web and said tear strip and sealing said label at said cut by
30 overlapping said cut with a label portion.

25. The method of claim 21, further comprising: establishing a hinge portion by cutting through said first web at a location adjacent an end portion of said tear strip and sealing said label at said cut by overlapping said location with a label portion.

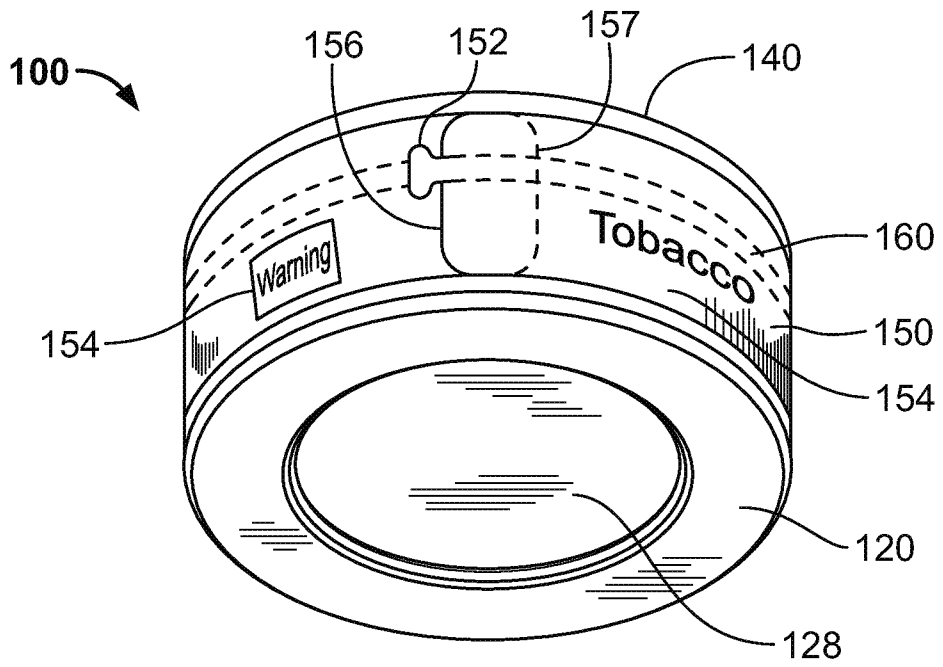

FIG. 1A

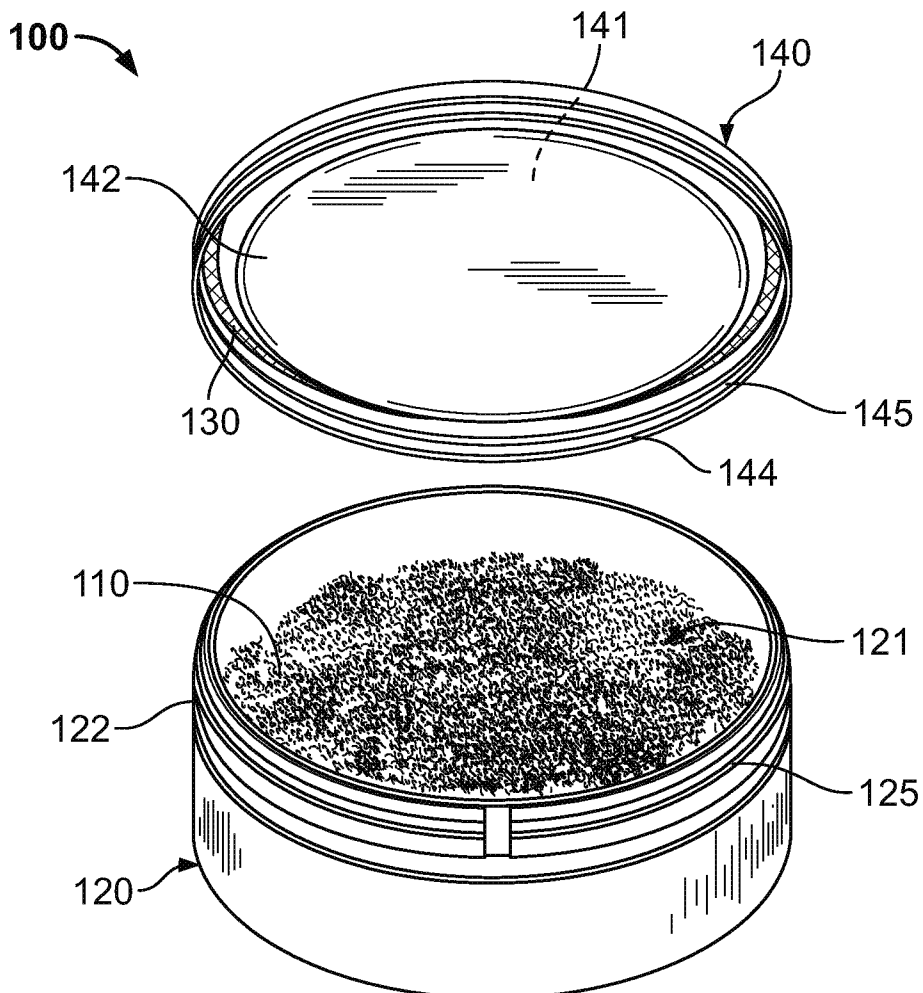
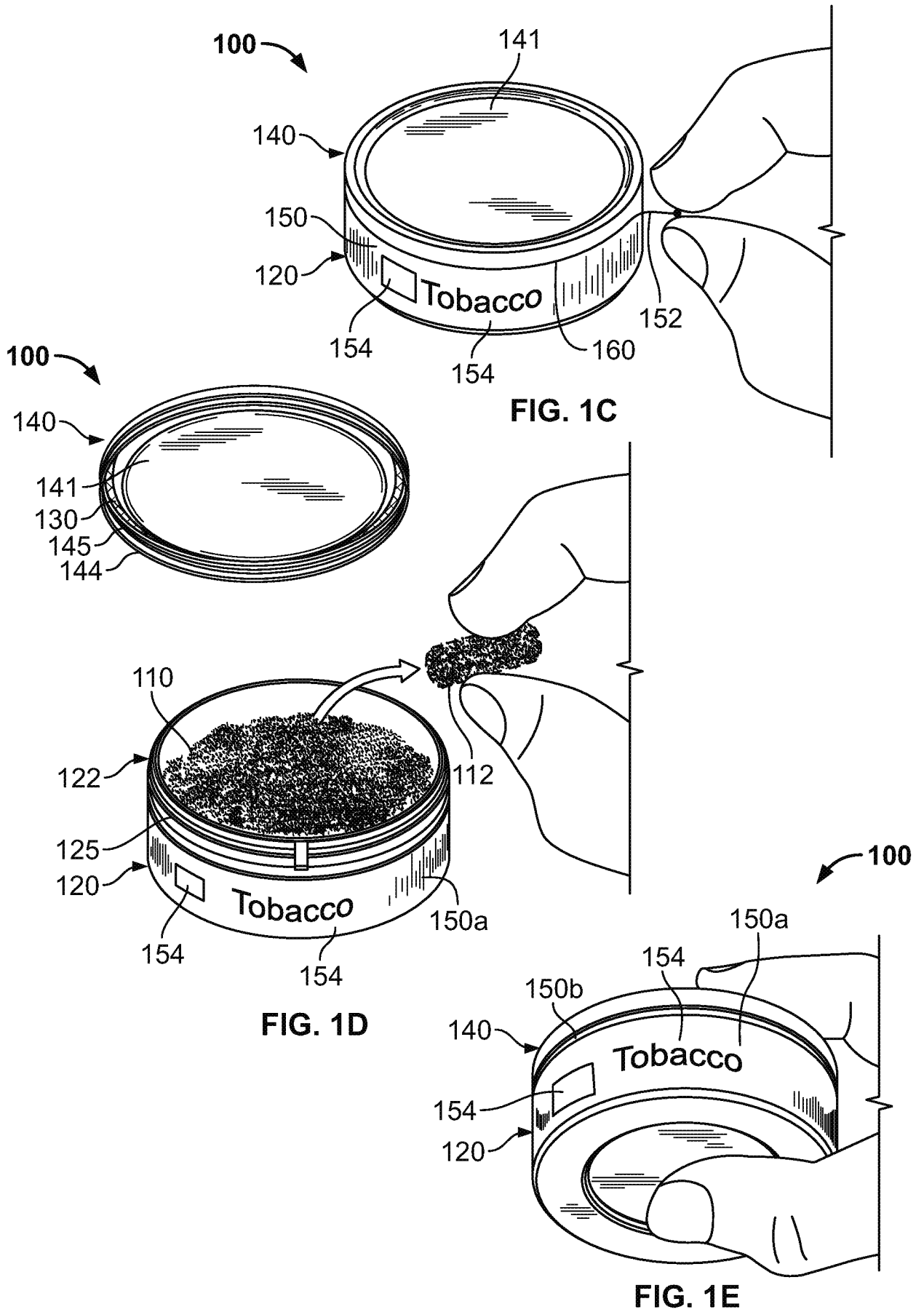

FIG. 1B



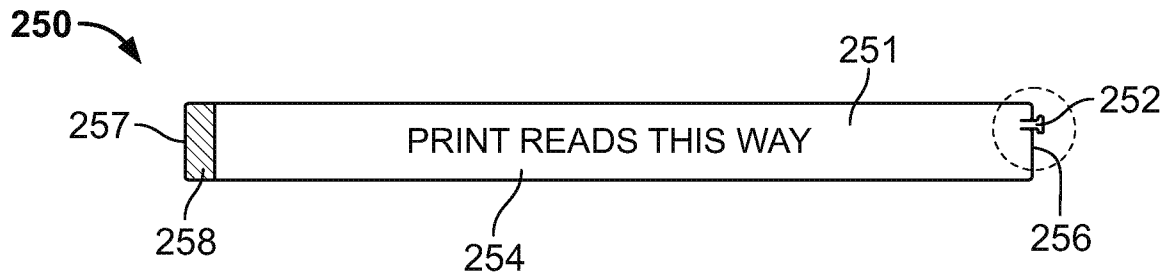

FIG. 2A

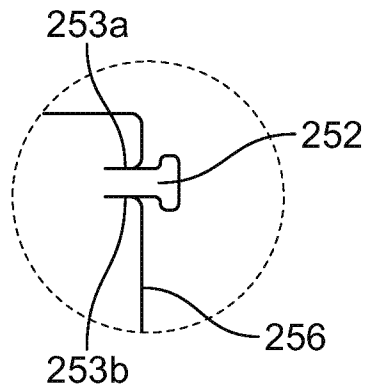

FIG. 2B

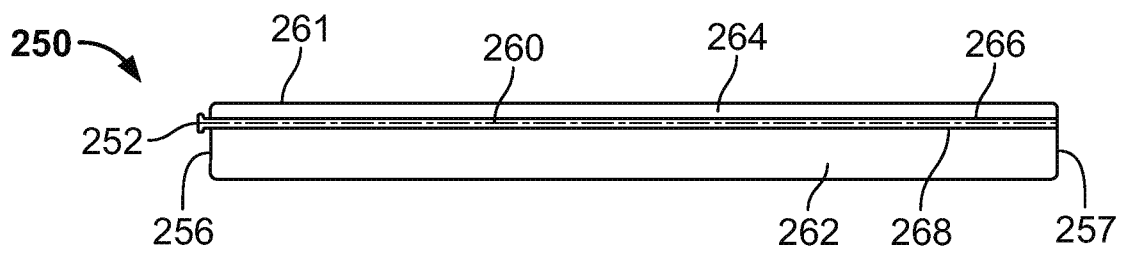

FIG. 2C

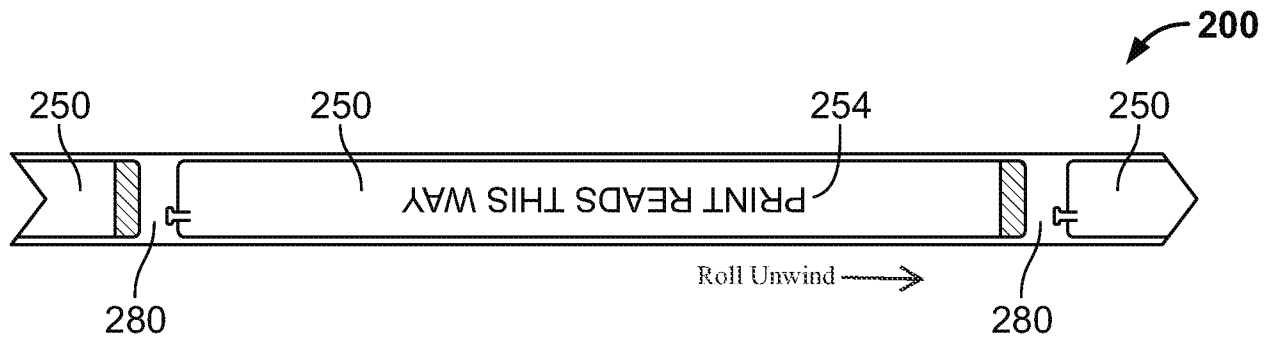

FIG. 2D

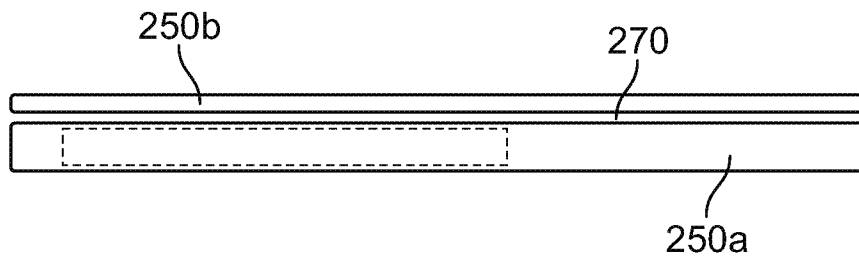

FIG. 2E

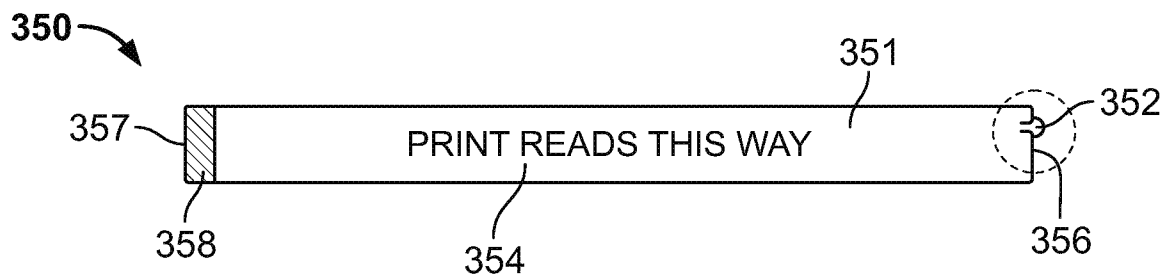

FIG. 3A

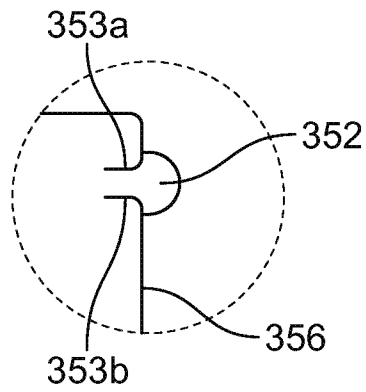

FIG. 3B

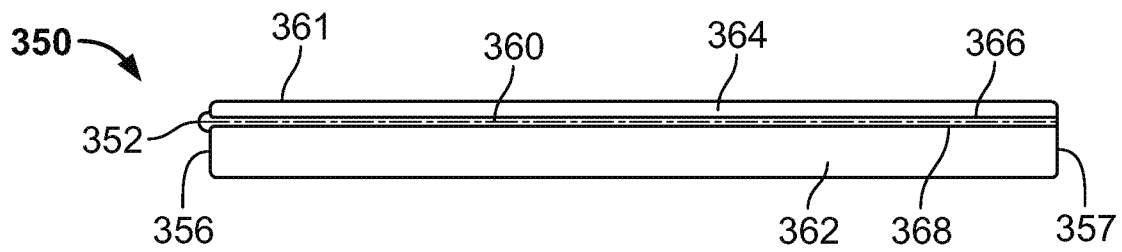

FIG. 3C

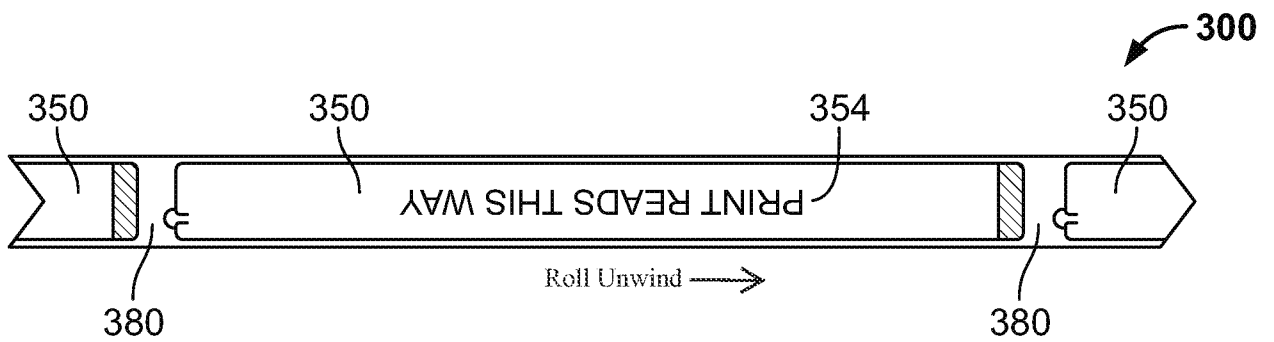

FIG. 3D

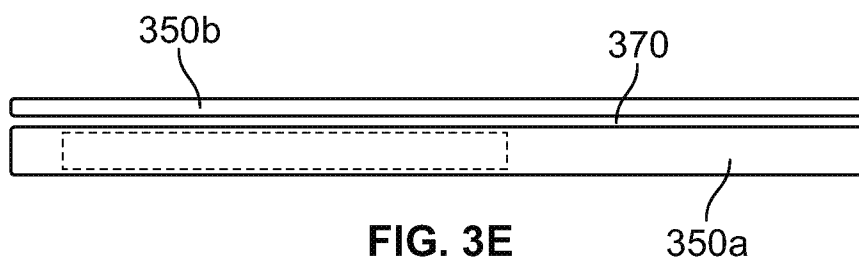

FIG. 3E

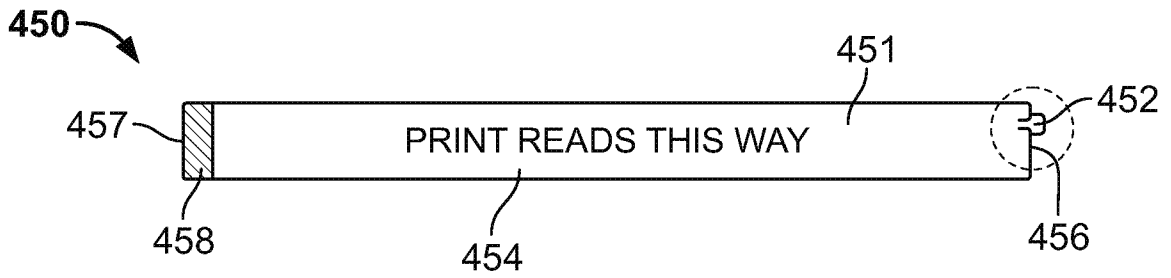

FIG. 4A

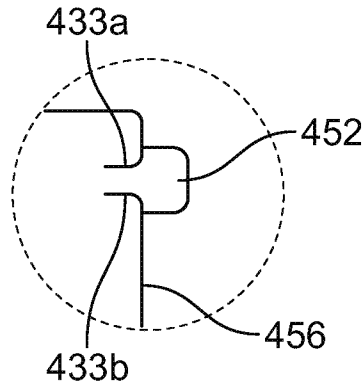

FIG. 4B

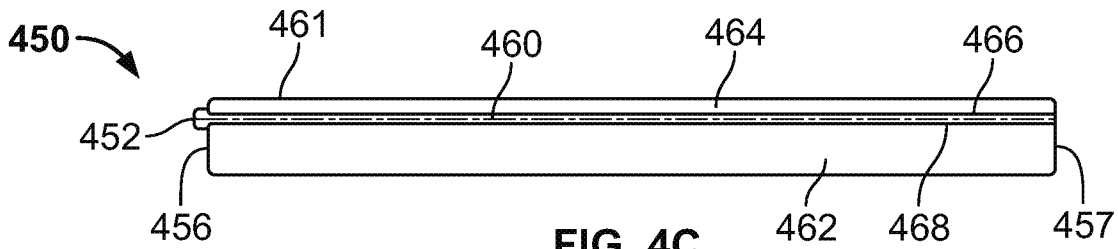

FIG. 4C

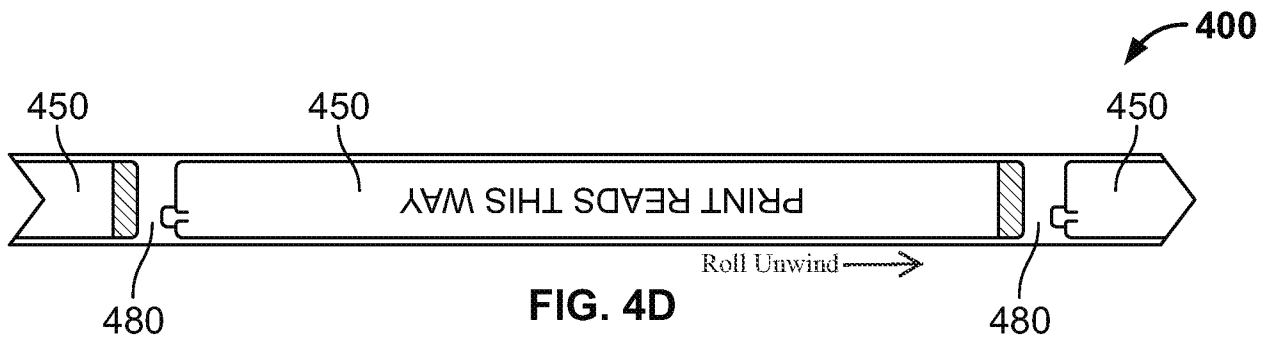

FIG. 4D

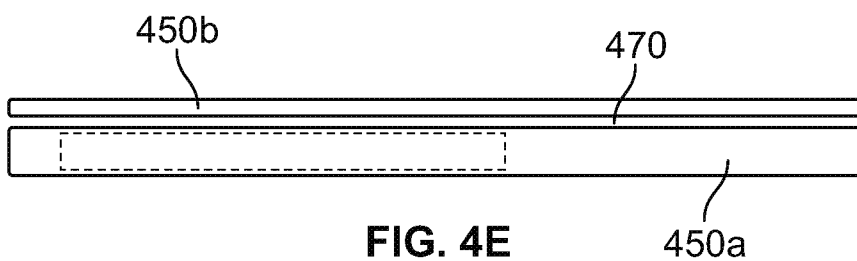
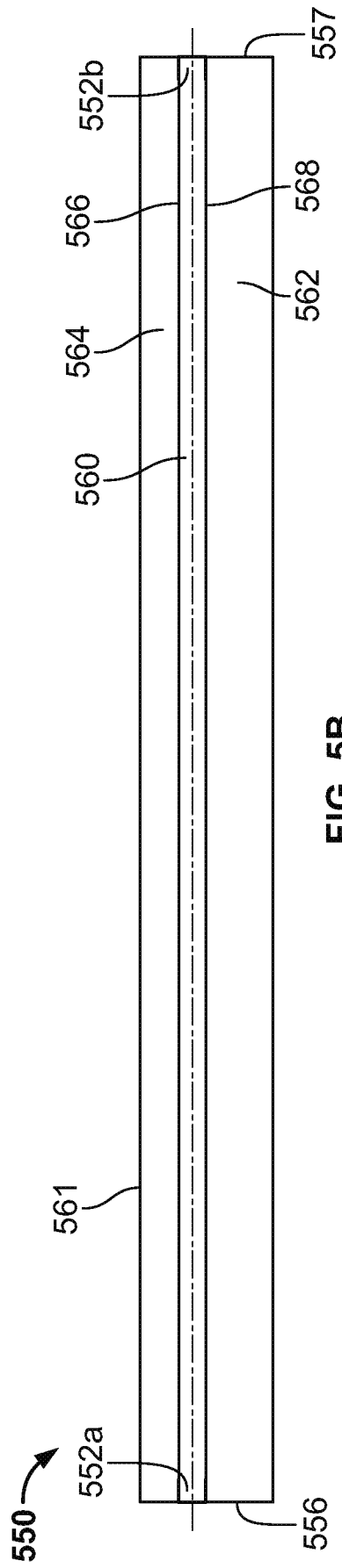
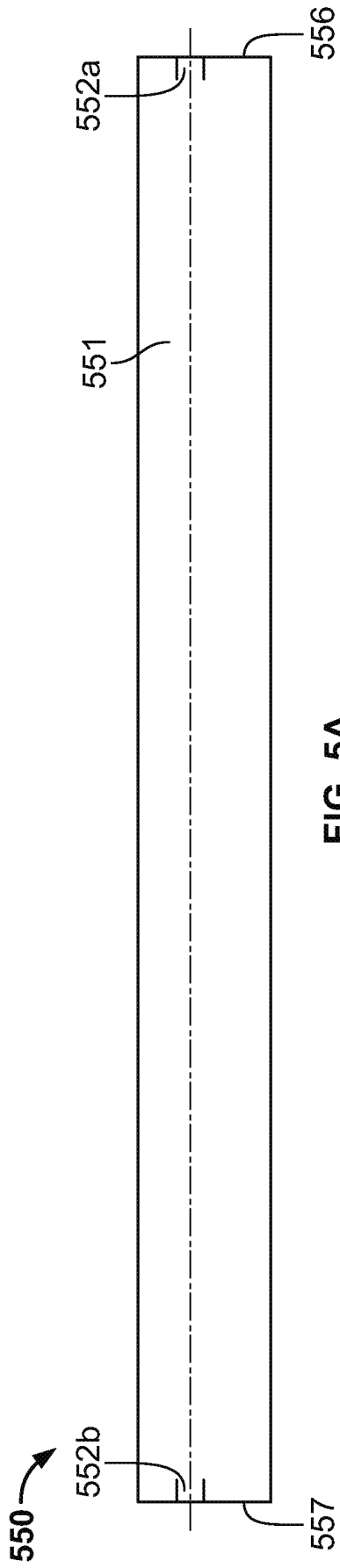

FIG. 4E



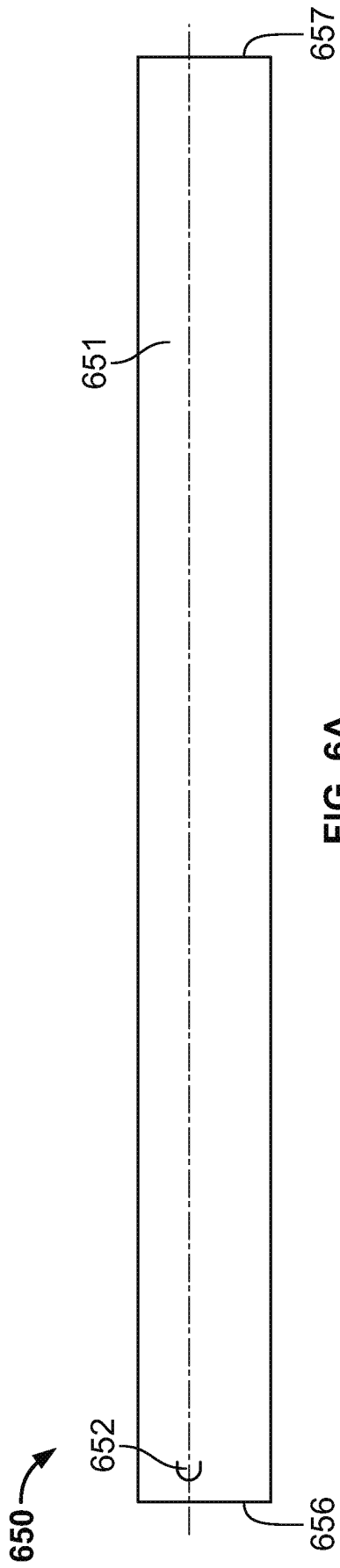

FIG. 6A

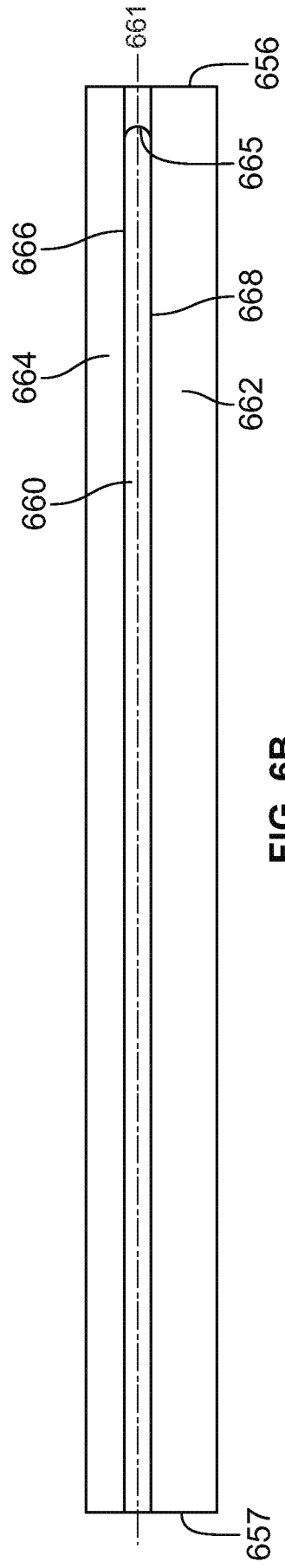
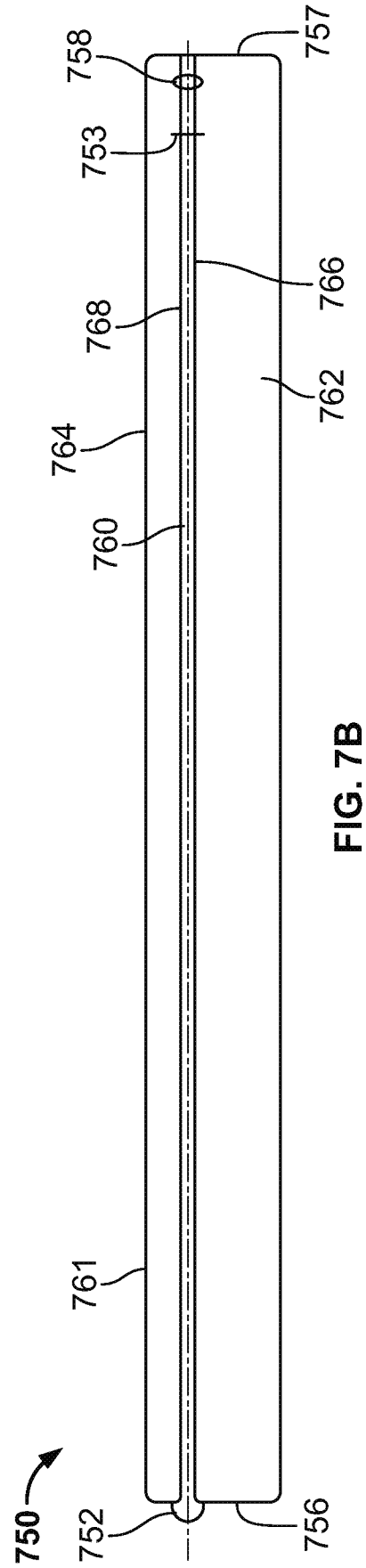
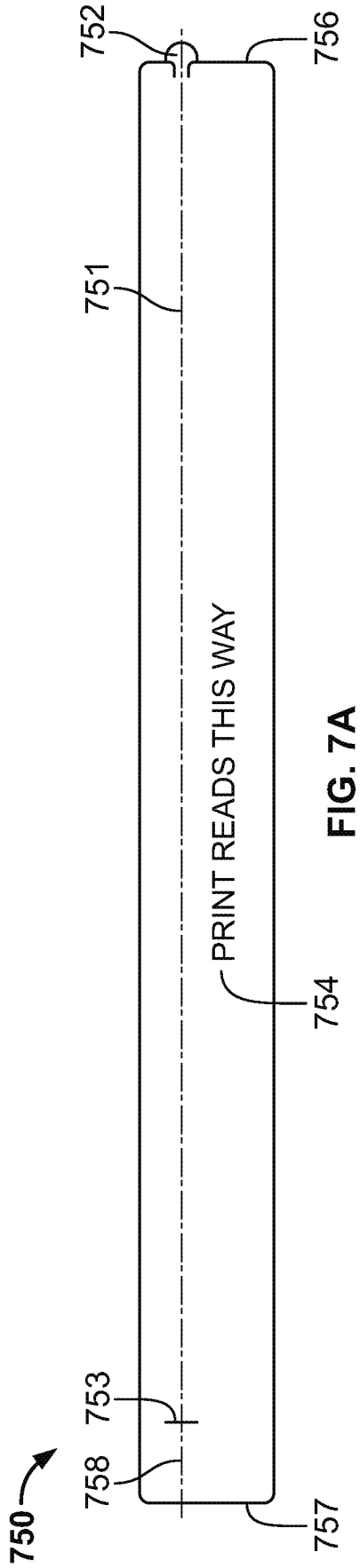
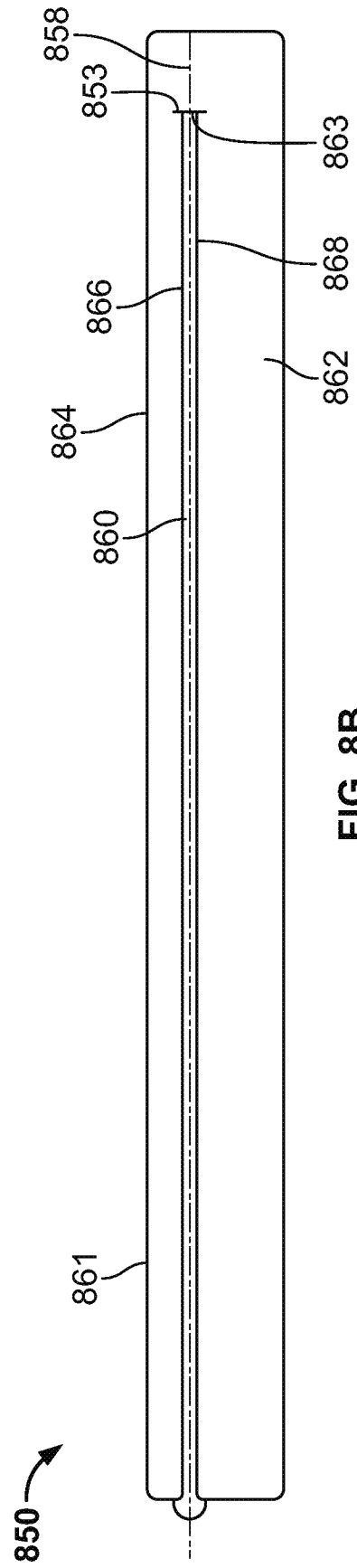
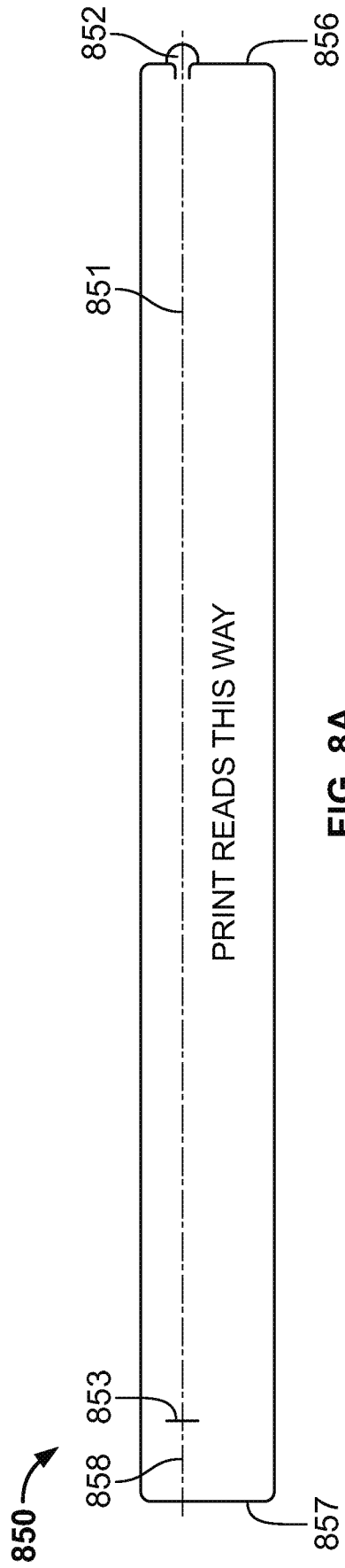

FIG. 6B





INTERNATIONAL SEARCH REPORT

International application No
PCT/US2014/024711

A. CLASSIFICATION OF SUBJECT MATTER
INV. B65D55/08 G09F3/03
ADD.
According to International Patent Classification (IPC) or to both national classification and IPC

B. FIELDS SEARCHED
Minimum documentation searched (classification system followed by classification symbols)
B65D G09F

Documentation searched other than minimum documentation to the extent that such documents are included in the fields searched

Electronic data base consulted during the international search (name of data base and, where practicable, search terms used)
EPO-Internal, WPI Data

C. DOCUMENTS CONSIDERED TO BE RELEVANT

Category*	Citation of document, with indication, where appropriate, of the relevant passages	Relevant to claim No.
A	EP 2 248 736 A1 (BRITISH AMERICAN TOBACCO CO [GB]) 10 November 2010 (2010-11-10) paragraph [0003]; figure 2 -----	1,20
A	US 3 873 018 A (DONNAY JAMES A) 25 March 1975 (1975-03-25) column 2, line 18 - line 22; figure 5 -----	1,20

Further documents are listed in the continuation of Box C. See patent family annex.

* Special categories of cited documents :

"A" document defining the general state of the art which is not considered to be of particular relevance	"T" later document published after the international filing date or priority date and not in conflict with the application but cited to understand the principle or theory underlying the invention
"E" earlier application or patent but published on or after the international filing date	"X" document of particular relevance; the claimed invention cannot be considered novel or cannot be considered to involve an inventive step when the document is taken alone
"L" document which may throw doubts on priority claim(s) or which is cited to establish the publication date of another citation or other special reason (as specified)	"Y" document of particular relevance; the claimed invention cannot be considered to involve an inventive step when the document is combined with one or more other such documents, such combination being obvious to a person skilled in the art
"O" document referring to an oral disclosure, use, exhibition or other means	"&" document member of the same patent family
"P" document published prior to the international filing date but later than the priority date claimed	

Date of the actual completion of the international search 24 June 2014	Date of mailing of the international search report 03/07/2014
---	--

Name and mailing address of the ISA/ European Patent Office, P.B. 5818 Patentlaan 2 NL - 2280 HV Rijswijk Tel. (+31-70) 340-2040, Fax: (+31-70) 340-3016	Authorized officer Bridault, Alain
--	---

INTERNATIONAL SEARCH REPORT

Information on patent family members

International application No

PCT/US2014/024711

Patent document cited in search report	Publication date	Patent family member(s)	Publication date
EP 2248736	A1	10-11-2010	CA 2702562 A1 08-11-2010
			DK 2248736 T3 10-03-2014
			EP 2248736 A1 10-11-2010
			EP 2551212 A1 30-01-2013

US 3873018	A	25-03-1975	NONE
