

Nov. 11, 1947.

T. J. TAHENY

2,430,790

NON-REFILLABLE BOTTLE CLOSURE

Filed June 30, 1945

Fig. 1.

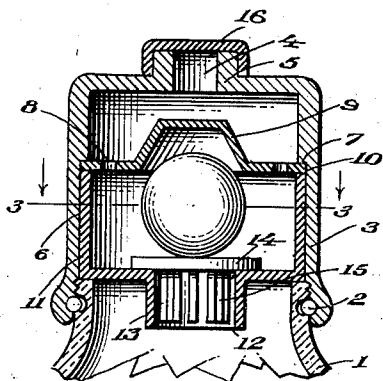

Fig. 2.

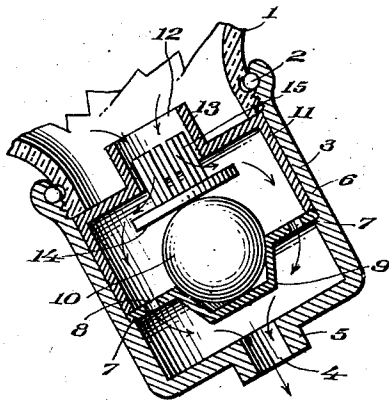

Fig. 4.

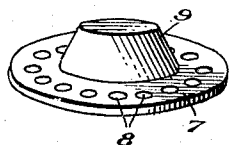

Fig. 5.

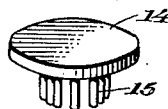
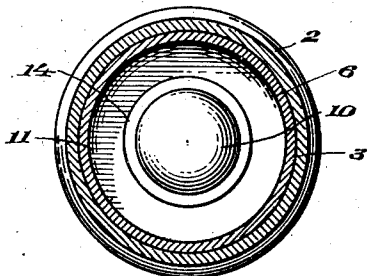

Fig. 3.



INVENTOR

Thomas J. Taheny

BY *Victor J. Evans & Co.*

ATTORNEYS

UNITED STATES PATENT OFFICE

2,430,790

NONREFILLABLE BOTTLE CLOSURE

Thomas J. Taheny, Pawtucket, R. I.

Application June 30, 1945, Serial No. 602,480

3 Claims. (Cl. 215—22)

1

My present invention has reference, in its broad aspect, to improvements in non-refillable bottles, and more particularly, it is my purpose to provide a non-refillable valve and closure arrangement having no screw threads, and which is formed of but few parts easily assembled, and those parts being sturdy and practical, and having no intricate accessories which are likely to become broken or deranged or otherwise inapt for use. Neither can the valve and parts be tampered with and temporarily put out of order. Since one of the main uses of non-refillable bottles is to guard against surreptitious filling of a bottle with inferior or adulterated contents and the like and then palming it off as the original product. Reliability of the valve and the structure is one of the most requisite characteristics, and this my bottle is designed to fulfill.

Other and equally important objects and advantages of my invention will be apparent from the following description and drawings, and it is pointed out that changes may be made in form, size, shape, materials, and construction and arrangement of parts without departing from the purview of my broad inventive concept, or the scope of the appended claims.

In the drawings, wherein I have illustrated a preferred form of my invention:

Figure 1 is a longitudinal section showing the valve closed against refilling;

Figure 2 is a longitudinal section showing the contents of the bottle being poured and the valve open;

Figure 3 is a transverse section on the line 3—3 of Figure 1;

Figure 4 is a perspective view of the valve-seating ball guard, and

Figure 5 is a perspective view of the valve which is closed by the ball to prevent refilling of the bottle.

In the drawings, wherein like characters of reference are used to designate like or similar parts:

The numeral 1 designates a bottle of any suitable type which has a suitable lock 2 for the dispensing cap 3 so that the cap is fixed to the bottle neck. The cap 3 may be of any suitable material and is cylindrical, and has the dispensing opening 4 at the top about which is a collar 5. The interior wall of the cap is enlarged, as at 6, to form a seat 7.

In assembling the cap prior to fixing it on the bottle, there is seated against the seat 7 a valve-seating ball guard 8 having a series of openings 9 through which fluid may pass in either direc-

2

tion—in or out of the bottle, and a truncated-conical central depression 9 in which is received the valve seating ball 10. A cylindrical sleeve 11 is assembled against the cap 3, which sleeve has a dispensing opening 12 with a collar 13. A valve 14 closes the opening 12 and is normally held in position by a series of spaced apart fingers 15. The fingers 15 prevent displacement of the valve 14. When the bottle 1 is tipped to the position shown in Figure 2, the ball falls into the depression 9 and permits the valve 14 to open sufficiently to dispense the contents of the bottle, but when the bottle is in the position shown in Figure 1, the ball 10 closes the valve 14 so that the bottle may not be refilled. A cap 16 is provided for the cap 3.

From the foregoing it is believed that the operation and advantages of my invention will be apparent, but it is again emphasized that interpretation of the scope of my invention should only be conclusive when made in the light of the subjoined claims.

I claim:

1. A non-refillable bottle, comprising a cylindrical cap with a dispensing opening, a collar surrounding said opening, a cap on said collar, the interior wall of the cap enlarged to form an annular seat, a guard mounted on the seat and having openings through which fluid freely passes a ball underlying said guard and engageable with said guard, frustro-conical cavity formed in the guard to receive the ball, a cylindrical sleeve mounted against the guard and containing an opening for dispensing the contents of the bottle, a depending collar on said sleeve around the opening therein, a circular disk valve for closing the opening, spaced fingers on the lower surface of the valve to position the valve, and the ball movable to hold the valve in the opening to prevent introducing refilling contents through the opening in the sleeve, but movable to permit dispensing the contents of the bottle.

2. The invention as defined in claim 1 wherein the fingers are in uniform spaced circular relationship on the bottom of the valve, and fit in the opening in the sleeve, and wherein the ball moves to an inactive position permitting opening of the valve to dispense the contents when the bottle is tilted to pouring position, but moves to closing position with respect to the valve when the bottle is in vertical position to prevent refilling the bottle.

3. The invention as defined in claim 1 wherein the cap is locked on the bottle, and wherein both the sleeve and cap are telescoping and cylindrical

3

in cross-section, and one seats within the other and the sleeve is held in seated position on the mouth of the neck of the bottle when the cap is fixed on the neck of the bottle.

THOMAS J. TAHENY. 5

REFERENCES CITED

The following references are of record in the file of this patent:

Number
2,053,191
2,133,758
2,179,510
2,179,511
2,382,864
2,082,267

10

4**UNITED STATES PATENTS**

Number	Name	Date
	Crossman -----	Sept. 1, 1936
	Taheny -----	Oct. 18, 1938
	Kolts -----	Nov. 14, 1939
	Kolts -----	Nov. 14, 1939
	Diaz y Diaz -----	Aug. 14, 1945
	Stattmann -----	June 1, 1937