

Dec. 10, 1968

M. A. PROVI ET AL

3,414,909

CLAMP-ON GRAB BAR OR RAIL FOR BATHTUBS OR THE LIKE

Filed Sept. 15, 1966

2 Sheets-Sheet 1

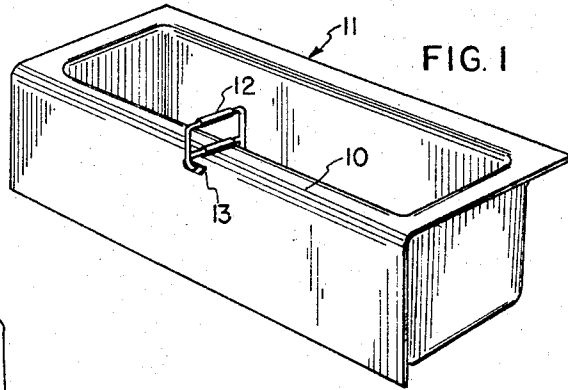

FIG. 2

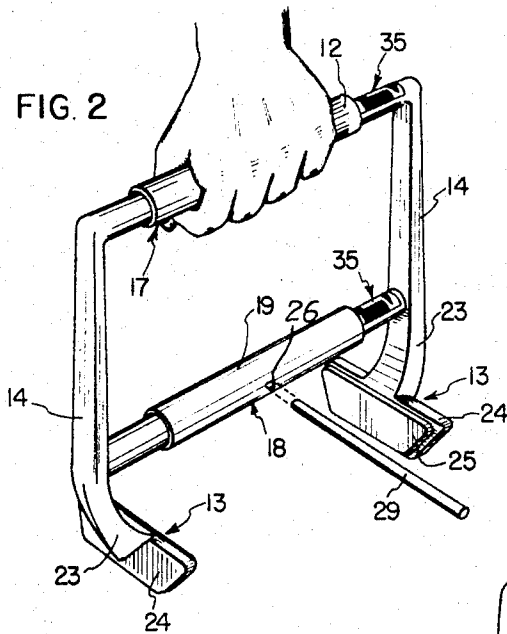

FIG. 3

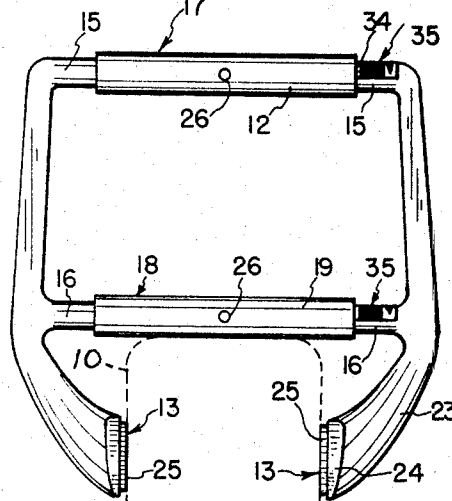
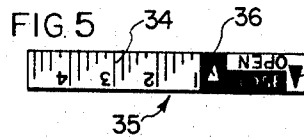
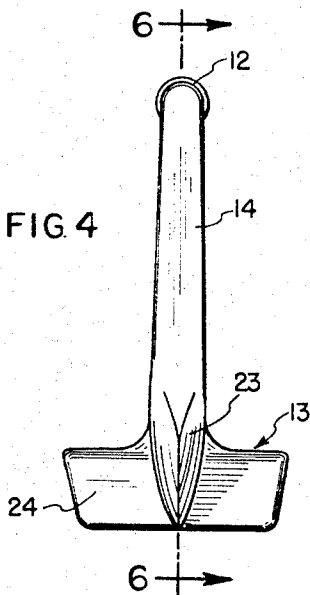

FIG. 4



INVENTORS.  
MIKE A. PROVI  
S. ROBERT GUNTER

BY

*Andrew F. Winterstein*  
Atty.

Dec. 10, 1968

M. A. PROVI ET AL

3,414,909

CLAMP-ON GRAB BAR OR RAIL FOR BATHTUBS OR THE LIKE

Filed Sept. 15, 1966

2 Sheets-Sheet 2

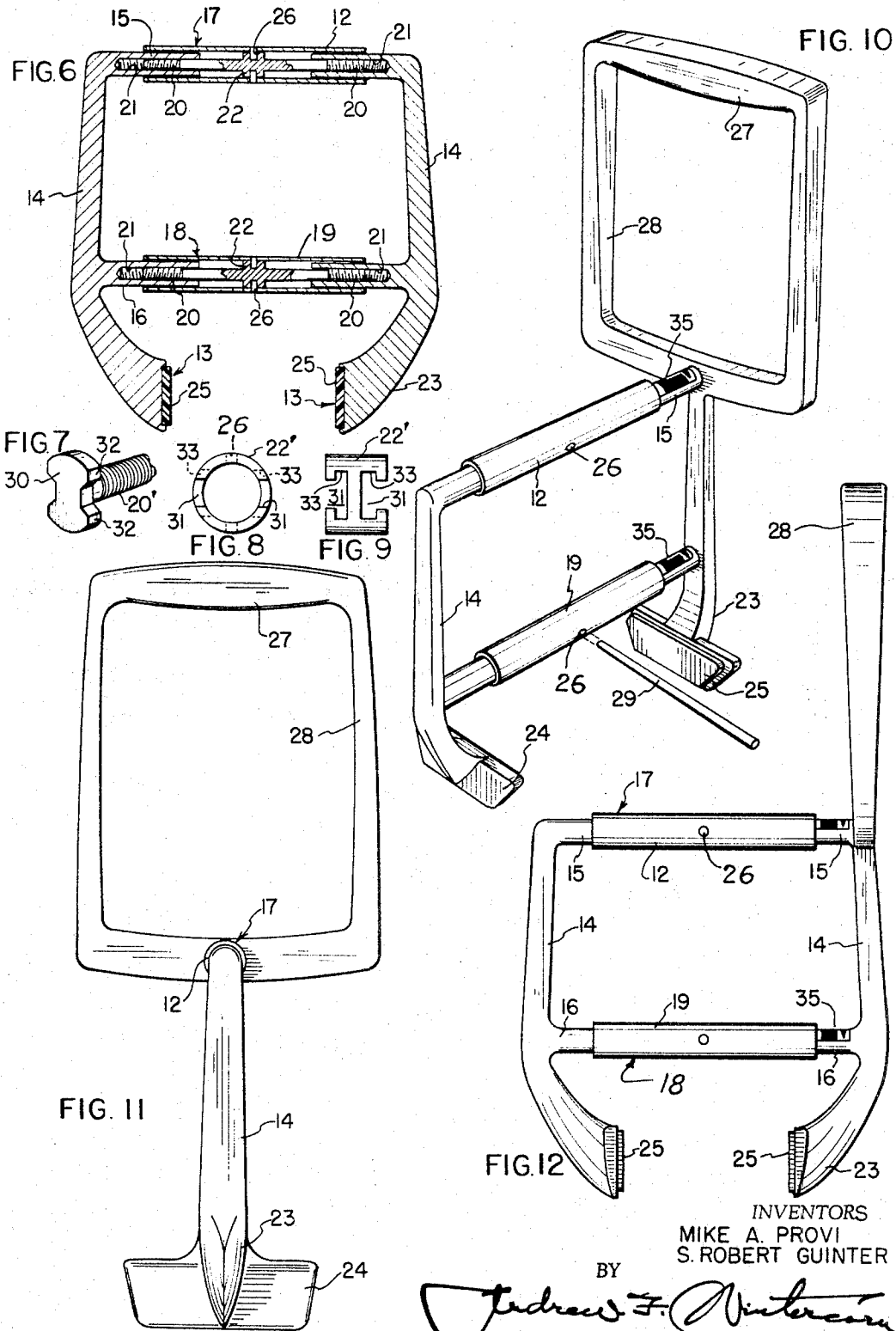

INVENTORS  
MIKE A. PROVI  
S. ROBERT GUNTER

BY

*Andrew F. Vinter*  
Atty.

1

2

3,414,909  
**CLAMP-ON GRAB BAR OR RAIL FOR  
 BATHTUBS OR THE LIKE**

Mike A. Provi and S. Robert Guinter, Rockford, Ill.,  
 assignors to The Brearley Company, Rockford, Ill., a  
 corporation of Illinois

Filed Sept. 15, 1966, Ser. No. 579,621  
 17 Claims. (Cl. 4—185)

This invention relates generally to a clamping device and, more particularly, to a safety grab bar or rail for bathtubs or the like adapted to be clamped to the upper edge portion of the outer vertical side wall of a bathtub.

A general object of the invention is to provide a novel clamping device of the above character which is easy to manipulate which is of simple and inexpensive construction, and which is readily adaptable for use with bathtubs of different constructions having different spacings and/or inclinations of the sides of their outer side walls.

Another object is to provide a bathtub safety rail which may be installed on a tub quickly and easily without requiring any special tools.

A more detailed object is to achieve the foregoing object by a novel construction utilizing the safety rail itself as an adjusting member for clamping the device to the tub side wall.

The invention also resides in a novel modification having hand grasping surfaces extending both longitudinally and transversely of the tub side wall.

Other objects and advantages of the invention will become apparent from the following detailed description taken in connection with the accompanying drawings in which:

FIGURE 1 is a perspective view of a bathtub equipped with a clamp-on grab bar or rail embodying the novel features of the present invention;

FIG. 2 is a perspective view of the device on a larger scale showing a user's hand in operating position;

FIG. 3 is a side elevational view of the device, indicating the side wall of a tub in dotted lines;

FIG. 4 is an end elevational view;

FIG. 5 is an enlarged plan view of an adjusting guide strip, like those shown in FIGS. 2 and 3;

FIG. 6 is a sectional view taken along the line 6—6 of FIG. 4, showing the couplings;

FIG. 7 is a fragmentary perspective view of an adjusting screw for a modified coupling;

FIG. 8 is an end elevational view of a collar of one adjustable coupling using two screws of the kind shown in FIG. 7;

FIG. 9 is a plan view of the collar;

FIG. 10 is a perspective view of a modified form of safety device, and

FIGS. 11 and 12, respectively, are side and elevational views of the modified form.

The clamping device shown in the drawings to illustrate the present invention is especially adapted to be mounted on the upper edge portion of the side wall 10 of a bathtub 11 and provide a grab rail or bar 12 which is spaced above the wall and is grasped by one hand of the user to steady himself as he steps into or out of the tub. The inner and outer sides of the wall are engaged by clamping jaws 13 which are adjustable toward and away from each other to vary the clamping pressure and accommodate walls having different thicknesses and different inclinations of their inner and outer sides with respect to the vertical.

In accordance with the present invention, the clamping device is of simple and inexpensive construction enabling

it to be mounted on bathtubs of different configurations quickly and easily without any special tools. The device thus comprises two generally C-shaped body members 14 each having spaced parallel upper and lower legs 15 and 16 aligned with the upper and lower legs of the other member and connected thereto by adjustable couplings 17 and 18 which permit movement of the legs and therewith the body members toward and away from each other. The clamping jaws 13 are carried by the respective body members and move with the members and into and out of engagement with the sides of the bathtub wall 10. The hand rail 12 is a part of the upper coupling 17 which joins the upper legs and this coupling includes at least one threaded connection for shifting the legs toward and away from each other as the rail is turned. The lower coupling 18 is of a similar construction with another bar 19.

In one form of the improved clamping device shown in FIGS. 1 to 5, each of the two coupling bars 12 and 19 takes the form of a cylindrical sleeve telescoping over the adjacent ends of the associated legs 15 and 16 of the body members 14 and having a threaded connection with each leg. To provide a wide range of adjustment and avoid threads on the exposed exterior portions of the legs, the threaded connections preferably are screws 20 having threads of opposite hand on their opposite ends and having cylindrical hubs or collars 22 integral with their midportions and pressed into the middle of the sleeves 12 and 19, so as to be rotatable and coaxial with the sleeves, the threaded ends of the screws being threaded into bores 21 being in the adjacent ends of the legs (FIG. 6), these being cylindrical to telescope closely within the sleeves. Radial holes 26 are drilled through the sleeves into the hubs 22 to receive a pin or rod 29 to turn the screws to clamp the device onto the tub. In the modified form, the screws 20' of each coupling (FIGS. 7 to 9) are connected to the sleeve 12 or 19 by a cylindrical collar 22' which has a press fit in the sleeve midway between the ends thereof. To obtain a turnbuckle action, the two screws 20' at the opposite ends of each coupling have right hand and left hand threads, respectively. The T-head 30 of each screw fits into a T-slot 31 cut through the collar and parallel flat sides 32 are formed on opposite sides of the head to abut flat ends 33 of the slots so that the screw turns with the collar and the sleeve when they are turned by a pin 29. The collar 22' has holes 26 drilled therein through the sleeve to receive the pin 29. The fit of each screw head in its slots is loose enough to provide a universal joint of limited movement to reduce the likelihood of binding of the parts in the event one coupling is adjusted to the point where it has a different length than the other. Obviously, one or both of the sleeves 12 and 19 can be equipped with the coupling means of FIGS. 7—9.

The clamping jaws 13 are secured to and depend from the outer ends of the lower legs 16 and each preferably is formed integral with the body member 14 as a part of the same casting. Each jaw includes a vertical portion 23 extending downwardly from the lower leg in the plane of the legs and curving inwardly toward the other jaw. At their lower ends, the vertical portions terminate in horizontal portions 24 which extend transversely of the plane of the legs and are recessed to receive molded cushion pads 25 of suitable non-slip resilient material. These pads are cemented in the recesses and are thick enough to project outwardly from the recesses and beyond the horizontal portions and present opposed clamping faces to engage the opposite sides of the bathtub wall.

To reduce any tendency of binding of the parts of the couplings 17 and 18 as their lengths are changed, it is desirable that they be adjusted the same amounts in small increments. Uniformity in such adjustments to retain the couplings at substantially the same lengths during

installation is achieved easily through the provision of indicia 34 on the sleeves 12 and 19 and at least one of the cooperating legs 15 and 16 of each coupling. The indicia in this instance conveniently takes the form of graduations printed on pressure sensitive tapes 35 (FIG. 5) which are placed on the legs and telescope with the legs and into the sleeves. Arrows with "OPEN" and "CLOSE" legends indicate the proper directions to turn the sleeves to lengthen and shorten the couplings. Usually, the tapes 35 are removed promptly after installation of the safety device is complete.

In the use of the improved safety device, both adjusting bars 12 and 19 are turned to space the clamping jaws 13 apart far enough to receive the bathtub wall 10 between them. Then both bars are turned to move the clamping surfaces of the cushion pads 25 against opposite sides of the wall. The pin or rod 29 entered in the holes 26 enables easy turning and obtaining finally the necessary tightness of clamping on the tub. If the operator is careful not to tighten one coupling 17 or 18 too far at one time, there will be no difficulty in regard to binding, even if the construction of FIG. 6 is employed. If the construction of FIGS. 7 to 9 is used, there is less likelihood of a binding action. In either event, the guide strips 35 are helpful.

The upper grab bar 12 of the improved safety device as described thus far extends transversely of the bathtub side wall. In a modified form of the device illustrated in FIGS. 6, 7 and 8, there is provided an additional grab bar 27 which extends longitudinally of the wall and transversely of the other grab bar. The auxiliary bar conveniently may be formed as the upper side of a hollow rectangular frame 28 projecting upwardly from the outer end of one of the upper legs 15 in a plane normal to the plane of the legs. In other respects, the modified construction is the same as that of FIGS. 1 to 5.

It will be apparent that both forms of the improved safety device are of simple construction and easy to use with the grab bar 12 itself forming part of an adjustable coupling for varying the clamping pressure. With the modification of FIGS. 10 to 12, the user has a convenient choice between the lower bar 12 which extends transversely of the bathtub wall 10 or the higher one 27 which extends longitudinally.

While preferred embodiments have been shown and described, it will be understood that it is not intended to limit the invention by such disclosure but, rather, it is intended to cover all modifications and alternative constructions falling within the spirit and scope of the invention as defined in the appended claims.

We claim:

1. A clamping device adapted to be secured to a support having spaced surfaces facing in opposite directions away from each other, said device having, in combination, a pair of C-shaped body members each having spaced first and second parallel legs aligned with the first and second legs of the other member in a common plane, an upper adjustable coupling joining said first legs and including a first adjusting member having at least one threaded connection with the first legs for adjusting the legs toward and away from each other in response to turning of the adjusting member in opposite directions, a second adjustable coupling joining said second legs and including a second adjusting member having at least one threaded connection with the second legs for adjusting the second legs toward and away from each other in response to turning of the adjusting member in opposite directions, and two clamping jaws one rigid with and depending from the outer end of the second leg of each of said body members, said jaws having opposed clamping surfaces facing toward each other and engageable with said spaced surfaces of said support in rigid clamping relation upon turning of said adjusting member.

2. The device of claim 1 in which each of said adjusting members is a cylindrical sleeve telescoping at opposite

ends with the associated ones of said legs and having threaded connections with both legs.

3. The device of claim 2 in which each of said threaded connections comprises a screw rotatable and coaxial with the associated sleeve and threaded into a threaded bore in the associated one of said legs.

4. The device of claim 3 in which each of said screws has limited universal movement with respect to the associated sleeve to avoid binding when said couplings are of different lengths.

5. The device of claim 1 in which a rectangular handle is rigid with and projects laterally and outwardly from the outer end of one of said first legs and transversely of said common plane.

6. The device of claim 5 in which said handle is disposed in a plane substantially normal to said common plane.

7. The device of claim 1 in which indicia provided on each of said couplings shows the relative lengths of the couplings to facilitate adjustment of the couplings to the same length.

8. The device of claim 7 in which said indicia are graduations on removable pressure sensitive tape applied to at least one of said legs of each of said couplings.

9. A clamping device adapted to be secured to a support having spaced surfaces facing in opposite directions away from each other, said device having, in combination, a pair of C-shaped body members each having spaced first and second parallel legs aligned with the first and second legs of the other member in a common plane to form two pairs of aligned legs, the legs of each of said pairs of legs having a telescoping coupling to maintain the legs in alignment while permitting relative movement of said members toward and away from each other, at least one of said couplings including a rotatable adjusting member having a threaded connection with at least one of the legs of the associated pair for adjusting the legs and the body members toward and away from each other in response to turning of the adjusting member in opposite directions, and two clamping jaws one rigid with and depending from the outer end of the second leg of each of said body members, said jaws having opposed clamping surfaces facing toward each other and engageable with said spaced surfaces of said support in rigid clamping relation upon turning of said adjusting member.

10. A clamp-on grab bar or handle, for detachable connection with the device to which it is adapted to be attached, comprising two spaced substantially vertical side members on the lower ends of which are spaced parallel jaws adapted to embrace and clamp therebetween a portion of the device, an elongated tubular hand grip member in right angle relationship to and between the upper end portions of said side members disposed in telescoping relationship to aligned inward supporting projections provided on said side members, another tubular member in downwardly spaced parallel relationship to said handle member and disposed likewise in telescoping relationship to other aligned inward supporting projections provided on said side members, at least one of said tubular members being rotatable relative to its supporting projections, and threaded coupling means in the rotatable tubular member rotatable therewith and relative to the supporting projections in which said coupling means is threaded, whereby to draw said side members together and the clamping jaws with them so as to clamp onto the device.

11. A structure as set forth in claim 10, wherein the coupling means has a friction fit inside the tubular member, a radial hole being provided in the tubular member registering with a radial hole in the coupling means and adapted to receive a pin for manually rotating the sleeve and coupling means in tightening or loosening said jaws.

12. A structure as set forth in claim 10 in which a second hand grip is provided on a frame in rigid relation to one of said side members at one end of the first named hand grip and in transverse relationship thereto.

5

6

13. A clamp-on grab bar or handle, for detachable connection with the device to which it is adapted to be attached, comprising two spaced substantially vertical side members on the lower ends of which are spaced parallel jaws adapted to embrace and clamp therebetween a portion of the device, two elongated substantially horizontal tubular members disposed in vertically spaced parallel relationship and in substantially right angle relationship to and between the side members, each in telescoping relationship to aligned inward supporting projections provided on said side members, one of said tubular members being adapted to serve as a handle or grab bar, both tubular members being rotatable relative to their supporting projections, and threaded coupling means in each of said tubular members rotatable therewith and relative to the supporting projections in which said coupling means are threaded, whereby to draw said side members together and the clamping jaws with them so as to clamp onto the device.

14. A structure as set forth in claim 13 wherein each of said coupling means has a friction fit inside its surrounding tubular member in which it has a friction fit, a radial hole being provided in the tubular member registering with a radial hole in the coupling means and adapted to receive a pin for manually rotating the sleeve and coupling means in tightening or loosening said jaws.

15. A structure as set forth in claim 14 in which one

of the coupling means includes two screws threaded at their outer ends in the projections and having universal joint connections with one another and said sleeve at their inner ends.

16. The device of claim 13 in which indicia provided on each of said couplings shows the relative lengths of the couplings to facilitate adjustment of the couplings to the same length.

17. The device of claim 16 in which said indicia are graduations on removable pressure sensitive tape applied to one of the supporting projections for each member and exposed at one end of the tubular member.

#### References Cited

##### UNITED STATES PATENTS

2,756,439	7/1956	Bollen	4—185
2,794,666	6/1957	Bishman	294—16
2,931,051	4/1960	Sparling	4—185

20 LAVERNE D. GEIGER, *Primary Examiner*.

H. J. GROSS, *Assistant Examiner*.

U.S. Cl. X.R.

25 16—111, 124; 224—45; 248—228; 269—245; 294—16