

(19)  
(12)

(KR)  
(Y1)

(51) 。 Int. Cl.<sup>7</sup>  
G01N 21/47  
G01N 15/14

(45)  
(11)  
(24)

2004 11 10  
20-0367121  
2004 10 30

(21) 20-2004-0021479  
(22) 2004 07 28

(73) 268-2(2 )

(72) 561 1-306

2 10-110

2 406-33

312-603

104

:

(54)

(Particles)

(chamber) ;

가 .

3

- 1
- 2
- 3
- 4
- 5
- 6
- 7
- 8

\*\* \*\*

110, 210 ;      111, 211 ;  
112, 113 ;      212 ;  
120, 220 ;      121, 221 ;  
122, 222 ;      123, 223 ;  
124, 224 ;  
225 ;      (pass)226 ;  
130, 230 ;      131, 231 ;      A  
132 ;      133 ;  
232 ;      B234 ;  
235 ;  
236 ;

(Particles) ;      (chamber) ;

1

(111) (110) ; (chamber)(120) ; (130)  
 (112, 113) (123) (121)  
 (131) (132)  
 (132) 가 ,

( 1 micron )  
 가 (132)  
 (131) (133)  
 (132)

24) , (133) , (1)  
 , (123) , (131)  
 (132)

가 , 1 micron 가 .

(120,220)

가 (124, 224)

er) ; ; (chamb  
 ; ; (particle)  
 ; ;  
 ; ;  
 ; ;

가 가 가

가 .

가 .

2 (220) , (210) , (230)  
)가 .

3

(210) (211) ; (211)  
(211) , - , Nd:YAG 가 , (212)  
(212) , 3 , O-

(220) (212)  
(223) (225);

(223) ; (220) (223)  
(226)

(221) ;

(225) (223) (222) ;  
(225) (223) (221)

가 .

(225) (210) (223)

가 ( ) (221) . 3 5 (225)  
(210) (225)가

(212)

(223) A(231)

A(231)

B(232) ;

(234) ;

A(231)

(236) ;

가

(235) ;

(235)

(236)

(234)

) 가 . (236) (210)

, 3

(223)

A(231)

6

A(231)

A

4 (223)

7

(223) (226) (210) (221)

A(231)

8

가

가

(57)

1.

2.

3.

4.

5.

( )

4 6.

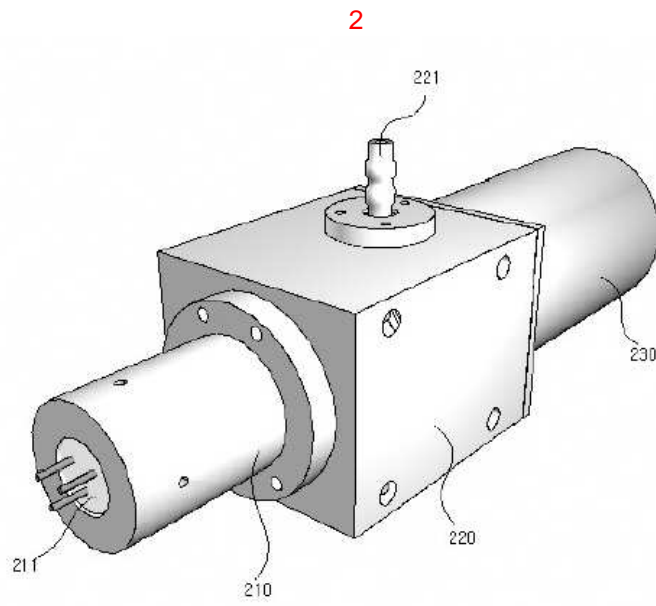
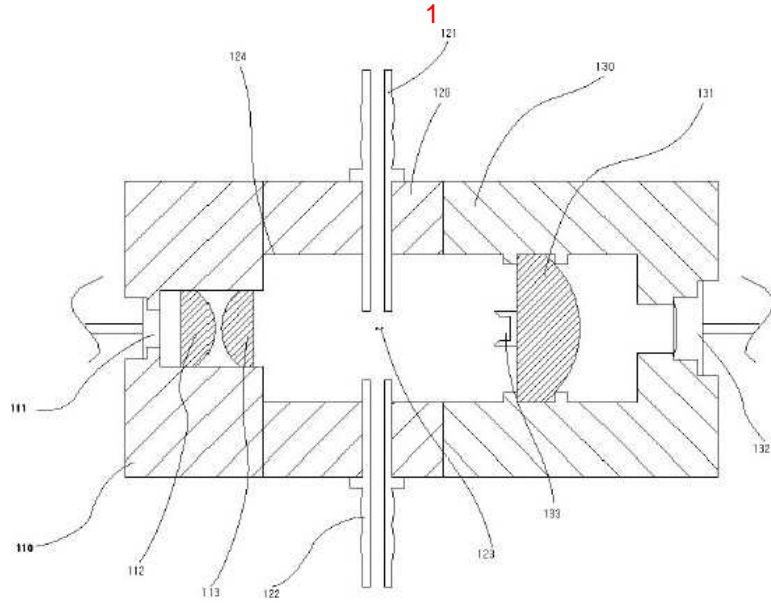

3

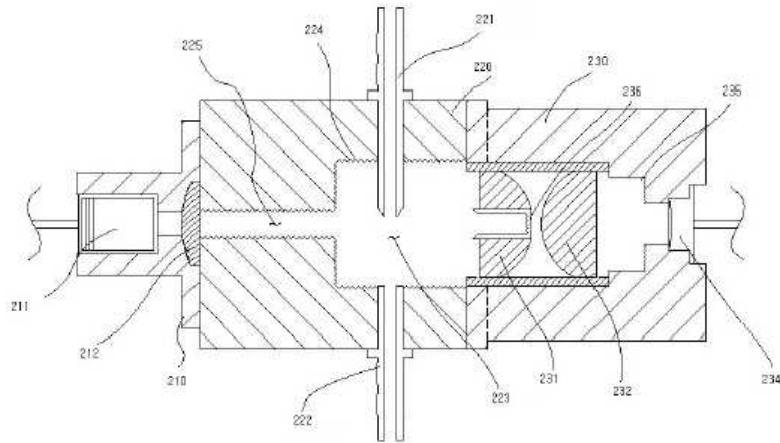

4

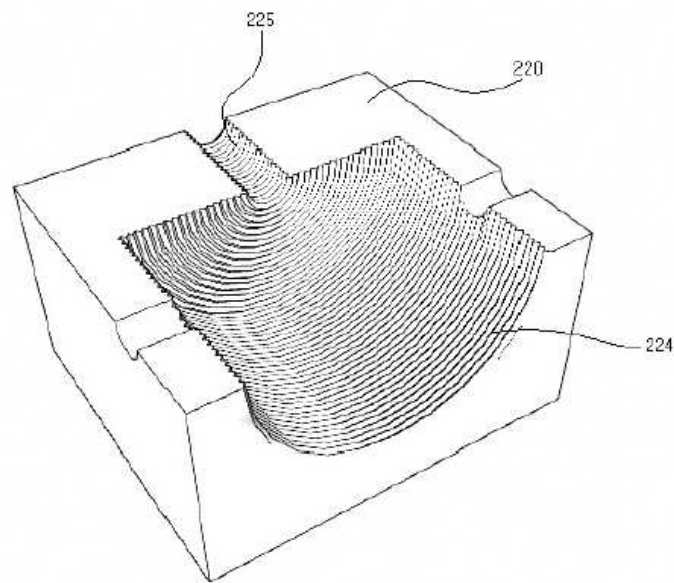

5

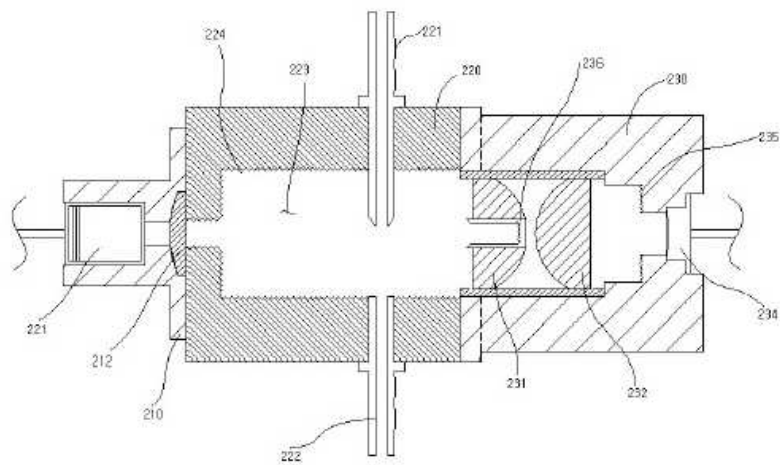

6

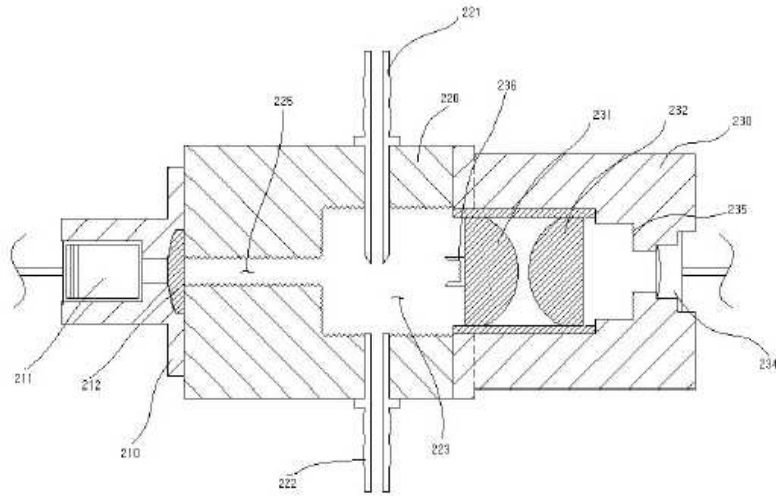

7

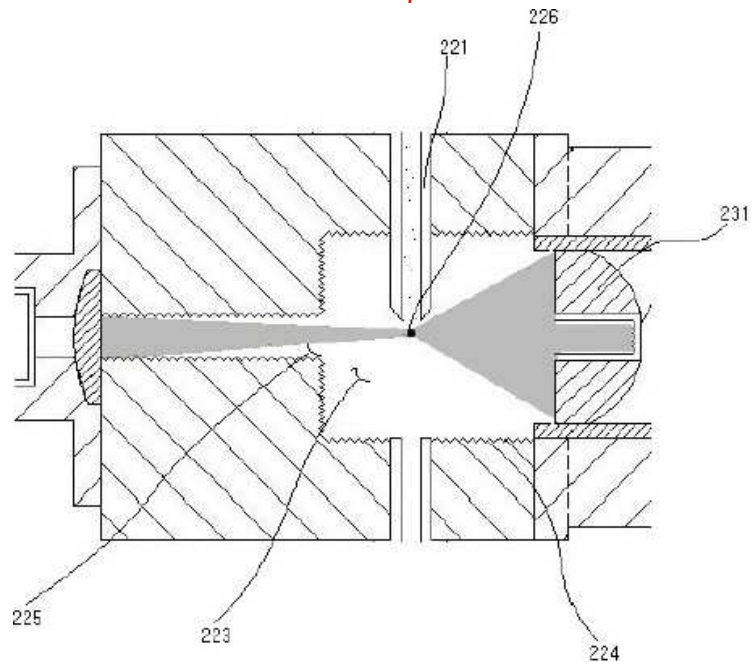

8

236

