

(19) World Intellectual Property Organization  
International Bureau



(43) International Publication Date  
5 December 2002 (05.12.2002)

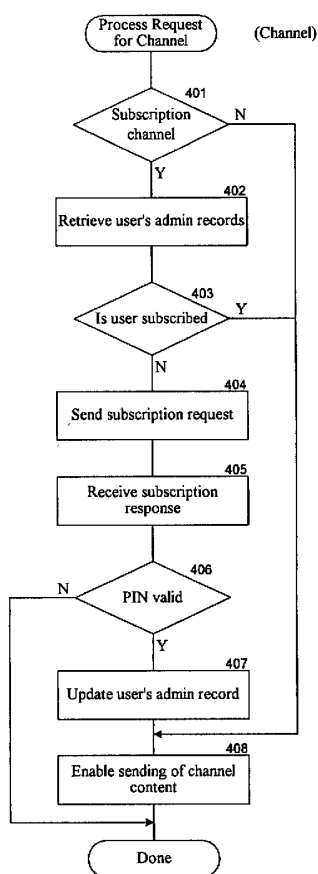
PCT

(10) International Publication Number  
WO 02/097997 A2

- (51) International Patent Classification<sup>7</sup>: **H03M** Woodinville, WA 98072 (US). **VOGEL, Derek, K.** [US/US]; 16920 128th Place NE, Woodinville, WA 98072 (US).
- (21) International Application Number: PCT/US02/17355
- (22) International Filing Date: 31 May 2002 (31.05.2002)
- (25) Filing Language: English
- (26) Publication Language: English
- (30) Priority Data:  
60/295,064 31 May 2001 (31.05.2001) US  
10/039,292 3 January 2002 (03.01.2002) US
- (71) Applicant (for all designated States except US): **MYRIO CORPORATION** [US/US]; 3500 Carillon Point, Kirkland, WA 98033 (US).
- (72) Inventors; and
- (75) Inventors/Applicants (for US only): **CEZEAUX, Thomas, Edward** [US/US]; 15429 135th Place NE,
- (74) Agents: **ARNETT, Stephen, E.** et al.; Perkins Coie LLP, P.O. Box 1247, Seattle, WA 98111-1247 (US).
- (81) Designated States (national): AE, AG, AL, AM, AT, AU, AZ, BA, BB, BG, BR, BY, BZ, CA, CH, CN, CO, CR, CU, CZ, DE, DK, DM, DZ, EC, EE, ES, FI, GB, GD, GE, GH, GM, HR, HU, ID, IL, IN, IS, JP, KE, KG, KP, KR, KZ, LC, LK, LR, LS, LT, LU, LV, MA, MD, MG, MK, MN, MW, MX, MZ, NO, NZ, OM, PH, PL, PT, RO, RU, SD, SE, SG, SI, SK, SL, TJ, TM, TN, TR, TT, TZ, UA, UG, US, UZ, VN, YU, ZA, ZM, ZW.
- (84) Designated States (regional): ARIPO patent (GH, GM, KE, LS, MW, MZ, SD, SL, SZ, TZ, UG, ZM, ZW), Eurasian patent (AM, AZ, BY, KG, KZ, MD, RU, TJ, TM), European patent (AT, BE, CH, CY, DE, DK, ES, FI, FR,

[Continued on next page]

(54) Title: REAL-TIME MONITORING AND BLOCKING OF CONTENT



(57) Abstract: Methods and systems for improving a user's experience with a set-top box. A system for allowing a user to subscribe to a subscription service when the user selects to view the content of the subscription service is provided. A system for replication of configuration information for set-top boxes is provided. A system for monitoring and blocking content being viewed by another is provided. A system that allows nontelevision programming content to be represented as a channel of an electronic program guide is provided.

WO 02/097997 A2



GB, GR, IE, IT, LU, MC, NL, PT, SE, TR), OAPI patent (BF, BJ, CF, CG, CI, CM, GA, GN, GQ, GW, ML, MR, NE, SN, TD, TG).

*For two-letter codes and other abbreviations, refer to the "Guidance Notes on Codes and Abbreviations" appearing at the beginning of each regular issue of the PCT Gazette.*

**Published:**

— *without international search report and to be republished upon receipt of that report*

## REAL-TIME MONITORING AND BLOCKING OF CONTENT

### BACKGROUND

[0001] The described technology relates generally to set-top boxes and various techniques for improving a user's experience when interacting with a set-top box.

[0002] Set-top boxes have been a widespread mechanism through which advanced programming features have been provided to television viewers or users. A set-top box connects a content feed (e.g., cable or satellite) to a television. A set-top box can control what content from the content feed is directed to the television. A set-top box may also interact with a content provider system to coordinate the providing of the custom content, such as on-demand programming.

[0003] A set-top box may also provide an electronic program guide to allow the users to view programming information for available television channels and to select which television channel to watch. Set-top boxes may access programming information (e.g., channel, title, and start time) provided through the content feed (e.g., on a designated channel) and generate a display of the information referred to as an electronic program guide. Electronic program guides are generally displayed in a grid format with start time information displayed horizontally and channel information displayed vertically. Each cell of the grid may contain the title of the content provided on that channel at that time. Set-top boxes typically allow users to use a remote control to scroll through the electronic program guide and select a channel to be watched.

[0004] Set-top boxes may also provide an interface through which users can configure their viewing experience. For example, a parent may

configure a set-top box to filter out any content that the parent might find objectionable. The user may also configure the set-top box to display electronic program guide information in various ways. For example, rather than displaying program guide information in channel order, a user may select to display the program guide information in genre order (e.g., news, soap operas, science fiction movies, and cooking).

[0005] Although set-top boxes help enhance the viewing experience, some capabilities provided by current set-top boxes are not particularly user-friendly or do not provide all the capabilities that users would like. For example, if a household has multiple set-top boxes, then a user would need to individually configure each set-top box, even though the user may want the same configuration at each set-top box. In addition, the set-top boxes cannot provide a user-friendly way for a viewer to subscribe to new services (e.g., HBO). As another example, the filtering mechanism of set-top boxes may not allow a parent sufficient control over the content viewed by their children. Finally, set-top boxes do not provide an integrated interface between channel content and Internet-based content.

#### BRIEF DESCRIPTION OF THE DRAWINGS

[0006] Figure 1 is a block diagram illustrating components of an interactive programming system in one embodiment.

[0007] Figure 2 illustrates an electronic program guide listing subscription services in one embodiment.

[0008] Figure 3 is a diagram illustrating a display that allows a user to subscribe to a service in one embodiment.

[0009] Figure 4 is a flow diagram illustrating the processing of a request to subscribe to a subscription service in one embodiment.

[0010] Figure 5 is a block diagram illustrating various configurations of set-top boxes and administrative servers for replication of configuration information in one embodiment.

[0011] Figure 6 is a flow diagram illustrating the updating of configuration information when the set-top boxes are connected via a local connection in one embodiment.

[0012] Figure 7 is a flow diagram illustrating the processing of a set-top box that receives updated configuration information via a local connection in one embodiment.

[0013] Figure 8 is a flow diagram illustrating the processing of a set-top box that receives updated configuration information from a user and replicates it via an administrative server in one embodiment.

[0014] Figure 9 is a flow diagram illustrating the processing of an administrative server component that replicates updated configuration information in one embodiment.

[0015] Figure 10 is a flow diagram illustrating the processing of a set-top box that receives updated configuration information from the administrative server in one embodiment.

[0016] Figure 11 is a flow diagram illustrating the processing of a set-top box that receives updated configuration information from a user and sends it to an administrative server for storage in one embodiment.

[0017] Figure 12 is a flow diagram illustrating the processing of the administrative server that receives the updated configuration information and stores it locally in one embodiment.

[0018] Figure 13 is a flow diagram illustrating the processing of a miscellaneous component of a set-top box that retrieves configuration information from an administrative server on as-needed basis in one embodiment.

[0019] Figure 14 is a flow diagram illustrating the processing of the administrative server in response to a request for configuration information in one embodiment.

[0020] Figure 15 is a block diagram illustrating the monitoring by a parent of content being viewed by a child in one embodiment.

[0021] Figure 16 is a block diagram illustrating the user interface for monitoring and blocking of content in one embodiment.

[0022] Figure 17 is a flow diagram illustrating the processing of monitoring the content of a child's television in one embodiment.

[0023] Figure 18 is a block diagram illustrating the display of an electronic program guide that displays Internet-based content as a channel in one embodiment.

[0024] Figure 19 is a block diagram illustrating the display of content associated with a nontelevision programming channel in one embodiment.

#### DETAILED DESCRIPTION

[0025] A method and system for subscribing to subscription services provided through a set-top box is provided. In one embodiment, the service selection system displays an electronic program guide that lists both subscription services and nonsubscription services. Each service may be represented as a separate channel on an electronic program guide. When a user selects a nonsubscription service, the system enables the transmitting of content associated with that nonsubscription service. When a user selects a subscription service, the system determines whether the user is currently subscribed to the selected subscription service. If the user is currently subscribed to the selected subscription service, the system enables the transmitting of content associated with that subscription service to the set-top box for display on the television. If the user is, however, not currently subscribed to the selected subscription service, the system displays a subscription form for the subscription service. The form allows the user to subscribe to the selected subscription service. The form may also request that the user enter authentication information. When the user is authenticated as appropriate, the system enables the transmitting of the content for the subscription service to the set-top box for display on the television. The system also subscribes the

user to the subscription service so that when the user subsequently selects the subscription service, the content of the subscription service will automatically be transmitted to the set-top box for display on the television. In this way, users can subscribe to subscription services through a set-top box at the time they want to view the content of the subscription service.

[0026] A method and system is also provided for replicating configuration data for set-top boxes. In one embodiment, the system provides a mapping of set-top boxes that are to share common configuration information. For example, all the set-top boxes in one household may share common configuration data. The system then receives from the user at one of the mapped set-top boxes updated configuration information. The configuration information may include filtering parameters, user interface configuration, and so on. The system then provides the received, updated configuration information to the other mapped, set-top boxes. Upon receiving the updated configuration information, the other set-top boxes update their configuration information. The configuration information can be provided to the other set-top boxes in various ways. In one embodiment, the set-top boxes may be interconnected via a local area network. In such an embodiment, the set-top box through which the user updated the configuration information may automatically send the updated configuration information via the local area network directly to the other set-top boxes. In an alternate embodiment, the set-top box through which the user updated the configuration information may send the updated configuration information to a remote server that then automatically sends the updated configuration information to the other set-top boxes that share common configuration information. Alternatively, each set-top box may maintain no local copy of the configuration information, but rather retrieve the configuration information on an as-needed basis from the remote server. In such a case, the set-top box through which the user updated the configuration information sends the updated configuration information to

the remote server for retrieval by the other set-top boxes on an as-needed basis. In this way, a user can update configuration information at one set-top box and have the updated configuration information automatically replicated at other set-top boxes, thus avoiding the difficulties of configuring each set-top box individually.

[0027] A method and system for monitoring, via a monitoring television, content being transmitted to a viewing (or monitored) television is provided. In one embodiment, the system receives from a user an indication to display on the monitoring television content being transmitted to the viewing television. For example, a parent may want to monitor through their television the content being viewed by their child on the child's television. The system may require authentication information from the user before monitoring can begin. Alternatively, certain set-top boxes and their connected televisions may be designated as authorized to monitor the content of other televisions for any user. In such a case, the user would not have to enter authentication information. Assuming the user is authenticated and authorized to monitor the content being transmitted, the system enables the content being transmitted to the viewing television to also be transmitted to the monitoring television. The system may also allow the user to block the transmission of the content that is currently being transmitted to the viewing television. For example, a parent, upon seeing the content that their child is currently viewing, may want to prevent the child from viewing that content. The system allows the parent, from their television, to both view the same content that the child is viewing and to block that content from being transmitted to their child's television. In this way, a user has "real-time" monitoring and filtering control over content being viewed by another.

[0028] A method and system for presenting television programming information and nontelevision programming information on a common electronic program guide is provided. The television programming



information may include conventional programming information, such as channel, time, and title. The nontelevision programming information may include Internet-based information and on-demand programming information. The Internet-based information may include information derived from various web pages that are accessible via the Internet. For example, the Internet-based information may include stock quote information, weather information, traffic information, and so on. The on-demand programming information may include movies that may be purchased on demand. The system displays an electronic program guide that includes a row for each channel of the provided television programming information and at least one row for the nontelevision programming information. When a user selects a channel corresponding to Internet-based information, that information is retrieved via the Internet and displayed. The system may also prompt the user to subscribe to the channel providing the Internet-based information as appropriate. When a user selects a channel corresponding to on-demand programming information, the system prompts the user to subscribe to the on-demand programming and then enables the transmitting of the content for the on-demand programming. In this way, the electronic program guide provides a uniform user interface for accessing content from various sources.

[0029] Figure 1 is a block diagram illustrating components of an interactive programming system in one embodiment. The interactive system comprises components that execute on content server 105 and set-top boxes 102. The content server receives content from various content feeds (or sources) 101. The content feeds may include pay-per-view movies transmitted via satellite, television programming transmitted via cable, and so on. The content server routes content selected by the subscriber or user to the appropriate set-top box. The set-top boxes control the display of the content on the televisions 103. The set-top boxes are responsible for interacting with the user to provide an electronic program guide. The

set-top boxes may also provide access to various content sources via the Internet 104. The Internet-based content may alternatively be provided only through the content server. The content server may include the content store 106 that contains videos that can be supplied to the set-top boxes on demand. Although not shown, the content server may contain databases of subscriber information, a billing component, an authentication component, and so on. In some embodiments, this may be a separate administrative server that manages this administrative information. In such a case, the set-top boxes may be connected to both servers, and the servers may be connected to each other. Also not shown, the configuration information for the set-top boxes may be stored at the set-top boxes themselves or at the content server 105.

[0030] The servers and set-top boxes may be computers that include a central processing unit, memory, input devices (e.g., keyboard and pointing devices, television and remote controls), output devices (e.g., display devices), and storage devices (e.g., disk drives). The memory and storage devices are computer-readable media that contain instructions that implement the system. In addition, the messages, data structures, and programming instructions of the system may be stored or transmitted via a data transmission medium, such as a signal or a communications link. In addition, the functionality of a set-top box may be built into a television.

#### Subscriber self-provisioning

[0031] As discussed above, the system may allow a user to subscribe to a new service at the time the user selects to view that service. Figure 2 illustrates an electronic program guide listing subscription services in one embodiment. The electronic program guide 200 includes channel identification information 201 and time slots 202. The rows 103 and 104 corresponding to channels 40 and 41 represent subscription services. In particular, row 103 represents the service HBO, which is currently transmitting the movie entitled "Gone with the Wind." A user can select a

channel by highlighting the channel using the arrow buttons on a remote control and then pressing the enter button, by directly entering the channel number on the numeric pad of the remote control, or by any other means for selecting a channel. When a channel for a subscription service is selected and the user is already subscribed to that service, then the system enables the transmitting of the content of that subscription service to the television for display. In contrast, if the user is not currently subscribed to that service, then the user is given the option to subscribe to that service. If the user decides to subscribe, then the system enables the transmitting of the content of that service to the television for display and records that the user has subscribed so that the enabling will occur automatically when the user selects the channel for that service in the future.

[0032] Figure 3 is a diagram illustrating a display that allows a user to subscribe to a service in one embodiment. The display 300 includes a dialog box 301. The dialog box identifies to the user that the user is currently not subscribed to the service and requests the user to enter their personal identification number ("PIN") 302 or other authentication information. To subscribe to the service, the user enters their PIN using, for example, the numeric pad of the remote control and presses the enter button on the remote control. One skilled in the art will appreciate that the entry of authentication information is optional and depends on the level of desired security. For example, the system may assume that anyone who has access to the set-top box is authorized to subscribe to the services and therefore would not prompt for authentication information. The set-top box forwards the information to the content server (or other server that provides administrative functions) which records the new subscription and enables the transmitting of the content for that subscription service to the user's television. When the user subsequently selects that service, the content of the subscription service is automatically transmitted to the user's television. Alternatively, rather than displaying the dialog box on a separate display,

the system may display the dialog box within the row of the electronic program guide associated with the subscription service.

[0033] Figure 4 is a flow diagram illustrating the processing of a request to subscribe to a subscription service in one embodiment. This processing is performed on a server that provides administrative services, such as tracking the services to which each user has subscribed. This processing is performed when a user selects to view a subscription service. In decision block 401, if the selected channel is a subscription channel (i.e., is assigned to a subscription service), then the component continues at block 402, else the component continues to block 408. In block 402, the component retrieves the administrative records for the user. The administrative records may be stored on a per-user, per-set-top box, or per-household basis. In decision block 403, if the user is currently subscribed to the selected channel, then the component continues at block 408, else the component continues at block 404. In block 404, the component sends a subscription request to the set-top box directing the set-top box to ask the user whether the user wants to subscribe to the selected subscription service and to provide authentication information. In block 405, the component receives the subscription response from the set-top box. In decision block 406, if the authentication information is valid, then the component continues at block 407, else the component completes. The component may also determine whether the user is authorized to subscribe to the service. For example, a child may provide their proper authentication information, but the child might not be authorized to subscribe to services. Before completing, the component may send a message to the set-top box indicating that the user could not be authenticated or is not authorized. In block 407, the component updates the user's administrative records to indicate the subscription to the service represented by the selected channel. In block 408, the component enables the transmitting of the content of the selected channel to the set-

top box and then completes. One skilled in the art will appreciate that various processes of this component could be performed at the set-top box, such as the process of authenticating the user.

#### Replication of configuration information

[0034] As described above, configuration information entered at one set-top box may be automatically propagated to other set-top boxes. Figure 5 is a block diagram illustrating various configurations of set-top boxes and administrative servers for replication of configuration information in one embodiment. The set-top boxes 501, 502, and 503 are connected to administrative server 510 via communications link 511. The communications link 511 may be a cable connection, a telephone-based connection, and so on. The set-top boxes may be interconnected via local area network 504. The set-top boxes 501, 502, and 503 have been designated to share common configuration information. When a user changes the configuration information at one of the set-top boxes, the system automatically replicates it to the other set-top boxes. The system can replicate the configuration information in various ways. First, the system may send the configuration information from one set-top box to the other set-top boxes via local area network 504 or some other local connection. For example, a user at set-top box 501 may change the filtering parameters of the set-top box. When the parameters have been changed, set-top box 501 then transmits the updated configuration information to set-top boxes 502 and 503 via the local area network. Upon receiving the updated configuration information, set-top boxes 502 and 503 update their configuration information. Second, the system may send the configuration information from one set-top box to the other set-top boxes via the administrative server. For example, a user at set-top box 501 may change the filtering parameters of the set-top box. When the parameters have been changed, set-top box 501 transmits the updated configuration information to the administrative server. Upon receiving the updated

configuration information, the administrative server identifies the set-top boxes that are to share common configuration information and then transmits the updated configuration information via communications link 511 to set-top boxes 502 and 503. Upon receiving the configuration information, the set-top boxes 502 and 503 update their configuration information accordingly. Third, the system may store the configuration information only at administrative server 510. When a set-top box updates configuration information, it retrieves the configuration information on as-needed basis from the administrative server via communications link 511. When a user at set-top box 501 changes the filtering parameters of the set-top box, the set-top box 501 transmits the updated configuration information to the administrative server. When the administrative server receives the updated configuration information, it stores it locally. When set-top boxes 502 and 503 next request configuration information, the administrative server provides the updated configuration information to the requesting set-top boxes.

[0035] Figures 6-14 are flow diagrams illustrating various scenarios for replicating updated configuration information from a set-top box. Figures 6-7 are flow diagrams illustrating processing in a scenario in which the set-top boxes are connected via a local connection. Figure 6 is a flow diagram illustrating the updating of configuration information when the set-top boxes are connected via a local connection in one embodiment. In block 601, the component receives updated configuration information from the user. The component may display the current values of the configuration information stored locally at the set-top box and request the user to enter the updated configuration information. In block 602, the component updates the configuration information stored at the set-top box. In block 603, the component sends the updated configuration information to the other set-top boxes via the local connection. The component may broadcast the updated configuration information over the local connection. Alternatively,

the set-top box may know which other set-top boxes share the common configuration information and direct the updated configuration information to those set-top boxes. Figure 7 is a flow diagram illustrating the processing of a set-top box that receives updated configuration information via a local connection in one embodiment. In block 701, the component receives the updated configuration information via the local connection. In block 702, the component updates the configuration information of the set-top box and then completes.

[0036] Figures 8-10 are flow diagrams illustrating processing in a scenario in which a set-top box replicates updated configuration information to the other set-top boxes via an administrative server. Figure 8 is a flow diagram illustrating the processing of a set-top box that receives updated configuration information from a user and replicates it via an administrative server in one embodiment. In block 801, the component receives the updated configuration information from the user. In block 802, the component updates the configuration information of the set-top box. In block 803, the component sends the updated configuration information to the administrative server and then completes. Figure 9 is a flow diagram illustrating the processing of an administrative server component that replicates updated configuration information in one embodiment. In block 901, the component receives the updated configuration information from a set-top box. In block 902, the component identifies the set-top boxes that share that configuration information. In block 903, the component sends the updated configuration information to the identified set-top boxes and then completes. Figure 10 is a flow diagram illustrating the processing of a set-top box that receives updated configuration information from the administrative server in one embodiment. In block 1001, the component receives the updated configuration information from the administrative server. In block 1002, the component updates the configuration information of its set-top box and then completes.

[0037] Figures 11-14 are flow diagrams illustrating processing in a scenario in which the set-top boxes send updated configuration information to an administrative server for distribution to other set-top boxes on an as-needed basis. Figure 11 is a flow diagram illustrating the processing of a set-top box that receives updated configuration information from a user and sends it to an administrative server for storage in one embodiment. In block 1101, the component retrieves the configuration information from the administrative server. In block 1102, the component receives updated configuration information from the user. In block 1103, the component sends the updated configuration information to the administrative server and then completes. Figure 12 is a flow diagram illustrating the processing of an administrative server that receives updated configuration information and stores it locally in one embodiment. In block 1201, the component receives updated configuration information from a set-top box. In block 1202, the component stores the updated configuration information so that it can be retrieved on an as-needed basis by the set-top boxes. The component then completes. Figure 13 is a flow diagram illustrating the processing of a miscellaneous component of a set-top box that retrieves configuration information from an administrative server on as-needed basis in one embodiment. In block 1301, the component requests the administrative server to provide configuration information. In block 1302, the component receives the configuration information from the administrative server. In block 1303, the component performs the miscellaneous processing that uses the received configuration information and then completes. Figure 14 is a flow diagram illustrating the processing of the administrative server in response to a request for configuration information in one embodiment. In block 1401, the component receives a request for configuration information from a set-top box. In block 1402, the component retrieves the configuration information for the set-top box. The administrative server may maintain information that indicates which set-top



boxes are to share common configuration information. In block 1403, the component sends the configuration information to the set-top box and then completes.

#### Real-time monitoring and blocking of content

[0038] As described above, the system allows one user to remotely monitor the content being viewed by another user and to optionally stop the transmitting of that content to the other user's television. In the case that the users are a parent and child, the system allows the parent to monitor the content being viewed by the child. The system allows the parent, from the parent's television, to view the content currently being transmitted to the child's television. The content being viewed by the child may be displayed in full-screen mode or as a picture-in-picture window on the parent's television. In either case, the parent can view the content that the child is currently viewing. The system allows the parent to optionally block the content from being transmitted to the child's television. When the system receives a request from the parent to block the content, the system notifies the administrative server to block the content currently being transmitted to the child's television. The administrative server may optionally request authentication information from the parent. The administrative server then records that the channel associated with the content currently being transmitted to the child's television is blocked from being transmitted to that television. The administrative server may direct the transmission of an indication that the channel is blocked or is temporarily unavailable when the child selects to display the content of that channel. Alternatively, depending on the processing power of the set-top boxes or gateway device at the parent's household, the monitoring and blocking may be handled locally without interaction with the administrative server.

[0039] Figure 15 is a block diagram illustrating the monitoring by a parent of content being viewed by a child in one embodiment. The child's

television 1501 is connected to the child's set-top box 1502, and the parent's television 1503 is connected to the parent's set-top box 1504. The set-top boxes are connected to an administrative server 1505. A parent may interact with the parent's television and the parent's set-top box to display the contents of the child's television on the parent's television. In this example, the child's content is shown in the upper right corner of the parent's television. Depending on the type of content being transmitted, the monitoring may be controlled locally by the set-top boxes, or the set-top boxes may interact with the administrative server. For example, if the content of the child's television is a conventional television channel, then the parent's set-top box need only request the child's set-top box to provide the number of the channel being viewed by the child (assuming a local connection) and then tune into that channel. When the parent selects to block the content, the parent's set-top box may send a message to the child's set-top box to disable the display of that channel. Alternatively, if the content of the child's television is a multicast, Internet-based transmission, then the parent's set-top box may request, via the administrative server, to join the same multicast group that the child's set-top box has joined. When the parent selects to block the content, the set-top box requests the administrative server to effect the leaving of the child's set-top box from the multicast group.

[0040] Figure 16 is a block diagram illustrating a user interface for monitoring and blocking of content in one embodiment. Initially, the parent's television displays conventional content as seen in display 1601. The parent then may use a remote control to direct the set-top box to enter a monitoring mode. The system may initially request authentication information from the parent as seen in display 1602. Upon entry of and verification of the authentication information, the system may display a list of the televisions that may be monitored by the parent as seen in display 1603. In this example, the parent can monitor the content of each of three

televisions. When the parent selects a child's television, the content of the child's television is displayed in the upper-right corner of the parent's television as seen in display 1604. The parent can then select to block that content from being transmitted to the child's television. As seen in display 1605, the content of the child's television now indicates that the channel the child is currently viewing is blocked.

[0041] Figure 17 is a flow diagram illustrating the processing of monitoring the content of a child's television in one embodiment. In this embodiment, the component executes on an administrative server that interacts with set-top boxes. Alternatively, this component may execute in a gateway computer in the parent's household. In block 1701, the component receives a request from a parent's set-top box to monitor a child's television. In block 1702, the component sends an authentication request to the parent's set-top box. In block 1703, the component receives the authentication information from the set-top box. In decision block 1704, if the authentication information is correct, then the component continues at block 1705, else the component completes. Before the component completes, it may send a notification to the parent's set-top box that the authentication information is incorrect. In block 1705, the component sends a list of the child televisions that can be monitored by the parent. The system may assume that all televisions in the same household may be monitored by any other television assuming a proper authentication and authorization, or the system may maintain a list of televisions that each television may monitor. In block 1706, the component receives a selection of a child's television. In block 1707, the component enables the transmitting of the content of the child's television to the parent's television. In block 1708, the component receives a request from the parent's set-top box. In decision block 1709, if the request indicates to block the content to the child's television, then the component continues at block 1710, else the component continues at block 1711. In block 1710, the component effects

the blocking of the transmission of the content to the child's television. In decision block 1711, if the request indicates to stop monitoring the child's television, the component continues at block 1712, else the component continues to process any other requests. In block 1712, the component disables the transmitting to the parent's television of the content currently displayed at the child's television and then completes.

#### Web-based content channel on electronic program guide

[0042] As described above, the system allows nontelelevision programming content to be represented as a channel in an electronic program guide. In particular, the system assigns a different channel of an electronic program guide to each type of Internet-based content or on-demand programming content. When a user selects a channel representing nontelelevision programming content, the system directs the content to be displayed on the user's television. Figure 18 is a block diagram illustrating the display of an electronic program guide that displays Internet-based content as a channel in one embodiment. In this example, channels 2 through 99 are allocated to television programming content and channels 100 through 103 are allocated to web-based content. The user interacts with the electronic program guide in a conventional manner to select any of the channels for television programming content or nontelelevision programming content. When a channel is selected, then the system effects the displaying of the content associated with that channel.

[0043] Figure 19 is a block diagram illustrating the display of content associated with a nontelelevision programming channel in one embodiment. In this example, the user selected channel 103 of Figure 18 that is associated with web-based, weather content. The system may generate the web-based content by retrieving a web page via the Internet from a weather-related web site. The system may effect the displaying of the retrieved web page (optionally disabling the navigation controls of the web browser) or may extract content of interest from the web page and reformat

it before displaying it on the television. Alternatively, the system may retrieve information via the Internet (e.g., weather, stock, and news) using other technologies such as the file transfer protocol ("FTP").

[0044] From the above, it will be appreciated that various embodiments of the invention have been described for purposes of illustration. One skilled in the art will appreciate that modifications may be made without deviating from the spirit and scope of the invention. Accordingly, the invention is not limited except as by the appended claims.

## CLAIMS

- [c1] 1. A method for monitoring via a monitoring television content being transmitted to a monitored television, the method comprising:  
receiving from a user an indication to display on the monitoring television content being transmitted to the monitored television;  
receiving from the user authentication information; and  
when the user can be authenticated and when the user is authorized to monitor the content being transmitted to the monitored television,  
enabling the transmitting of the content being transmitted to the monitored television to also be transmitted to the monitoring television; and  
in response to receiving from the user an indication to stop displaying on the monitoring television the content being transmitted to the monitored television, disabling the transmitting of the content being transmitted to the monitored television from also being transmitted to the monitoring television.
- [c2] 2. The method of claim 1 including  
in response to receiving from the user an indication to block the transmitting of the content to the monitored television, disabling the transmitting of the content from being transmitted to the monitored television.
- [c3] 3. The method of claim 1 wherein when the transmitting of the content to the monitored television is via multicasting, the enabling of the

transmitting of the content being transmitted to the monitored television to also be transmitted to the monitoring television includes having the monitoring television join a same multicast group as the monitored television.

[c4] 4. The method of claim 1 wherein the user of the monitoring television is a parent and a user of the monitored television is a child.

[c5] 5. A method for monitoring via a monitoring television content being transmitted to a monitored television, the method comprising:  
receiving from a user of the monitoring television an indication to display on the monitoring television content being transmitted to the monitored television;  
receiving from the user authentication information; and  
when the user can be authenticated,  
enabling the transmitting of the content being transmitted to the monitored television to also be transmitted to the monitoring television; and  
in response to receiving from the user an indication to block the transmitting of the content to the monitored television, disabling the transmitting of the content currently being transmitted to the monitored television.

[c6] 6. The method of claim 5 wherein when the transmitting of the content to the monitored television is via multicasting and the enabling of the transmitting of the content being transmitted to the monitored television to also be transmitted to the monitoring television includes having the monitoring television join a same multicast group as the monitored television.

[c7] 7. The method of claim 5 wherein the user of the monitoring television is a parent and a user of the monitored television is the parent's child.

[c8] 8. A system for monitoring via a monitoring television content being transmitted to a monitored television, comprising:

means for receiving from a user of the monitoring television an indication to display on the monitoring television content being transmitted to the monitored television;

means for enabling from the monitoring television the transmitting of the content being transmitted to the monitored television to also be transmitted to the monitoring television; and

means for disabling from the monitoring television the transmitting of the content currently being transmitted to the monitored television.

[c9] 9. The system of claim 8 wherein when the transmitting of the content to the monitored television is via multicasting and the means for enabling the transmitting of the content being transmitted to the monitored television to also be transmitted to the monitoring television includes means for effecting the joining of the monitoring television to a same multicast group as the monitored television.

[c10] 10. The system of claim 8 wherein the user of the monitoring television is a parent and a user of the monitored television is the parent's child.

[c11] 11. The system of claim 8 including means for authenticating the user.



[c12] 12. The system of claim 8 including means for disabling from the monitoring television the transmitting of the content being transmitted to the monitored television from also being transmitted to the monitoring television.

[c13] 13. A computer-readable medium containing instructions for controlling a system to monitor via a monitoring television content being transmitted to a monitored television, by a method comprising:

receiving from a user of the monitoring television an indication to display on the monitoring television content being transmitted to the monitored television; and

enabling the transmitting of the content being transmitted to the monitored television to also be transmitted to the monitoring television; and

in response to receiving from the user an indication to block the transmitting of the content to the monitored television, disabling the transmitting of the content currently being transmitted to the monitored television.

[c14] 14. The computer-readable medium of claim 13 wherein when the transmitting of the content to the monitored television is via multicasting and the enabling of the transmitting of the content being transmitted to the monitored television to also be transmitted to the monitoring television includes having the monitoring television join a same multicast group as the monitored television.

[c15] 15. The computer-readable medium of claim 13 wherein the user of the monitoring television is a parent and a user of the monitored television is the parent's child.

- [c16] 16. A method for replicating configuration information for a set-top box, the method comprising:
- providing an identification of set-top boxes that are to share a common configuration information;
  - receiving from a user at one of the identified set-top boxes updated configuration information to be shared by the identified set-top boxes; and
  - sending the received updated configuration data to another identified set-top box
- so that updates to the configuration information made at one of the identified set-top boxes effect a change in the configuration information for the other identified set-top box.
- [c17] 17. The method of claim 16 wherein the set-top box that receives the updated configuration information sends the updated configuration information to each of the other identified set-top boxes through a local connection.
- [c18] 18. The method of claim 17 wherein each of the identified set-top boxes stores its own copy of the common configuration information.
- [c19] 19. The method of claim 16 wherein the set-top box that receives the updated configuration information sends the updated configuration information to a server.
- [c20] 20. The method of claim 16 wherein upon receiving the updated configuration information the server sends the updated configuration information to each of the other identified set-top boxes.

- [c21] 21. The method of claim 20 wherein each of the identified set-top boxes stores its own copy of the common configuration information.
- [c22] 22. The method of claim 16 wherein the other set-top box retrieves the updated configuration data from the server as needed.
- [c23] 23. The method of claim 22 wherein the identified set-top boxes do not persistently store the common configuration information.
- [c24] 24. A computer-readable medium containing instructions for controlling a computer system to replicate configuration information for a set-top box, by a method comprising:  
receiving from a user at a set-top box updated configuration information; and  
automatically sending the received updated configuration information to another set-top box.
- [c25] 25. The computer-readable medium of claim 24 wherein the set-top box that receives the updated configuration information sends the updated configuration information to the other set-top boxes via a local connection.
- [c26] 26. The computer-readable medium of claim 25 wherein the other set-top boxes stores its own copy of the updated configuration information.
- [c27] 27. The computer-readable medium of claim 24 wherein the set-top box that receives the updated configuration information sends the updated configuration information to a server.

- [c28] 28. The computer-readable medium of claim 27 wherein upon receiving the updated configuration information the server sends the updated configuration information to the other set-top box.
- [c29] 29. The computer-readable medium of claim 28 wherein the other set-top box stores its own copy of the updated configuration information.
- [c30] 30. The computer-readable medium of claim 28 wherein the other set-top box retrieves the updated configuration information from the server as needed.
- [c31] 31. The computer-readable medium of claim 30 wherein the other set-top box does not persistently store the updated configuration information.
- [c32] 32. A computer system for replicating configuration information for a set-top box, comprising:  
means for receiving from a user at a set-top box updated configuration information; and  
means for sending the received updated configuration information to another set-top box.
- [c33] 33. The computer system of claim 32 including means for connecting the set-top box that receives the updated configuration information to the other set-top boxes via a local connection.
- [c34] 34. The computer system of claim 32 wherein the other set-top boxes stores its own copy of the updated configuration information.

[c35] 35. The computer system of claim 32 including means for sending the updated configuration information to a server.

[c36] 36. The computer system of claim 35 wherein upon receiving the updated configuration information the server sends the updated configuration information to the other set-top box.

[c37] 37. The computer system of claim 36 wherein the other set-top box stores its own copy of the updated configuration information.

[c38] 38. The computer system of claim 36 wherein the other set-top box retrieves the updated configuration information from the server as needed.

[c39] 39. The computer system of claim 38 wherein the other set-top box does not persistently store the updated configuration information.

[c40] 40. A method in a set-top box for selecting a service, the method comprising:

displaying an electronic program guide that lists a subscription service and nonsubscription service;

receiving from a user a selection of a service;

when a nonsubscription service is selected, enabling the transmitting of content associated to that nonsubscription service; and

when a subscription service is selected,

determining whether the user is currently subscribed to the selected subscription service;

when the user is currently subscribed to the selected subscription service, enabling the transmitting of

content associated with the selected subscription service;

when the user is currently not subscribed to the selected subscription service, displaying a subscription request for the subscription service;

in response to displaying the subscription request, receiving from the user an indication to subscribe to the selected subscription service along with authentication information; and

when the received indication indicates that the user can be authenticated,

subscribing the user to the selected subscription service so that a subsequent selection of the selected subscription service will result in the automatic enabling of the transmitting of the content associated with the selected subscription service; and

enabling the transmitting of content associated with the selected subscription service.

[c41] 41. The method of claim 40 wherein the authentication information is a personal identification number of the user.

[c42] 42. The method of claim 40 wherein the subscription form prompts the user to enter a personal identification number.

[c43] 43. The method of claim 40 wherein the subscription service is listed as a channel on the electronic program guide.

- [c44] 44. A method in a set-top box for selecting a subscription service, the method comprising:
- displaying an electronic program guide that lists the subscription service;
  - receiving from a user a selection of the subscription service;
  - determining whether the user is currently subscribed to the selected subscription service;
  - when the user is currently subscribed to the selected subscription service, enabling the transmitting of content associated with the selected subscription service;
  - when the user is currently not subscribed to the selected subscription service, prompting the user to subscribe to the selected subscription service;
  - in response to the prompting, receiving from the user a request to subscribe to the selected subscription service;
  - in response to receiving the request, subscribing the user to the selected subscription service so that a subsequent selection of the selected subscription service will result in the automatic enabling of the transmitting of the content associated with the selected subscription service without the prompting; and
  - enabling the transmitting of content associated with the selected subscription service.
- [c45] 45. The method of claim 44 wherein the prompting occurs within a portion of the electronic program guide associated with the subscription service.
- [c46] 46. The method of claim 44 wherein the prompting occurs by displaying a dialog box.

- [c47] 47. The method of claim 44 wherein the prompting occurs by displaying a subscription form.
- [c48] 48. The method of claim 44 wherein the received request includes authentication information for the user.
- [c49] 49. The method of claim 48 wherein the subscribing of the user to the selected subscription service occurs only when the user can be authenticated.
- [c50] 50. The method of claim 48 wherein the authentication information includes a personal identification number.
- [c51] 51. A method for subscribing to a subscription service associated with a television channel, the method comprising:  
receiving from a user a selection of the television channel; and  
upon receiving the selection,  
when the user is not currently subscribed to the subscription service associated with the television channel, asking the user to confirm subscribing to the subscription service; and  
when the user confirms the subscribing to the subscription service, subscribing the user to the subscription service so that next time the user selects the television channel the user will not be asked to subscribe and the content of the subscription service will be transmitted to the user.
- [c52] 52. The method of claim 51 wherein selection of the television is received via an electronic program guide.



- [c53] 53. The method of claim 51 wherein the selection of the television channel is received without using an electronic program guide.
- [c54] 54. The method of claim 53 wherein the selection of the channel is received by entry of a numeric code for the television channel.
- [c55] 55. The method of claim 53 wherein the selection of the channel is received by selection of a next channel.
- [c56] 56. The method of claim 51 including when the user confirms to subscribe to the subscription service, enabling the transmitting of the content of the subscription service to the user.
- [c57] 57. A computer-readable medium containing instructions for controlling a computer system to subscribe a user to a subscription service associated with a television channel, by a method comprising:  
receiving an indication of a television channel selected by a user;  
and  
upon receiving the indication,  
when the user is not currently subscribed to the subscription service associated with the television channel,  
asking the user to confirm subscribing to the subscription service; and  
when the user confirms the subscribing to the subscription service, subscribing the user to the subscription service so that next time the user selects the television channel the user will not be asked to subscribe and the content of the subscription service will be transmitted to the user.

- [c58] 58. The computer-readable medium of claim 57 wherein the user selects the television channel via an electronic program guide.
- [c59] 59. The computer-readable medium of claim 57 wherein the user selects the television channel without using an electronic program guide.
- [c60] 60. The computer-readable medium of claim 59 wherein the user selects the television channel by entry of a numeric code for the television channel.
- [c61] 61. The computer-readable medium of claim 59 wherein the user selects the television channel by selection of a next channel.
- [c62] 62. The computer-readable medium of claim 57 including when the user confirms to subscribe to the subscription service, enabling the transmitting of the content of the subscription service to the user.
- [c63] 63. A computer system for subscribing a user to a subscription service associated with a television channel, comprising:  
means for receiving an indication of a television channel selected by a user;  
means for asking the user to confirm subscribing to the subscription service when the user is not currently subscribed to the subscription service associated with the television channel;  
and  
means for subscribing the user to the subscription service when the user confirms the subscribing to the subscription service.
- [c64] 64. The computer system of claim 63 wherein the user selects the television channel via an electronic program guide.

- [c65] 65. The computer system of claim 63 wherein the user selects the television channel without using an electronic program guide.
- [c66] 66. The computer system of claim 65 wherein the user selects the television channel by entry of a numeric code for the television channel.
- [c67] 67. The computer system of claim 65 wherein the user selects the television channel by selection of a next channel.
- [c68] 68. The computer system of claim 63 including means for enabling the transmitting of the content of the subscription service to the user when the user confirms to subscribe to the subscription service
- [c69] 69. The computer system of claim 63 including means for authenticating the user.
- [c70] 70. A method for presenting an electronic program guide, the method comprising:  
providing television programming information;  
providing web site information; and  
displaying an electronic program guide that includes the provided television information and the web site information.
- [c71] 71. The method of claim 70 wherein the displayed electronic program guide includes a row for each channel of the television programming information and a row for each web page of the web site information.
- [c72] 72. The method of claim 71 including when a row for a web page is selected, displaying information derived from the web page.

[c73] 73. The method of claim 71 wherein the information derived from the web page excludes navigation features of the web page.

[c74] 74. The method of claim 70 including when the web site information is selected, displaying information retrieved from a web site.

[c75] 75. The method of claim 70 wherein web site information is displayed to approximate the display of a television channel.

[c76] 76. A method of selecting Internet-based content to display, the Internet-based content being allocated a channel number not allocated to broadcast content, the method comprising:

displaying the broadcast content associated with a currently selected channel number;

receiving a selection of another channel number, the other channel number being allocated to the Internet-based content; and

in response to receiving the selection of the other channel number, displaying the Internet-based content associated with the selected channel number.

[c77] 77. The method of claim 76 wherein the Internet-based content is derived from a web site.

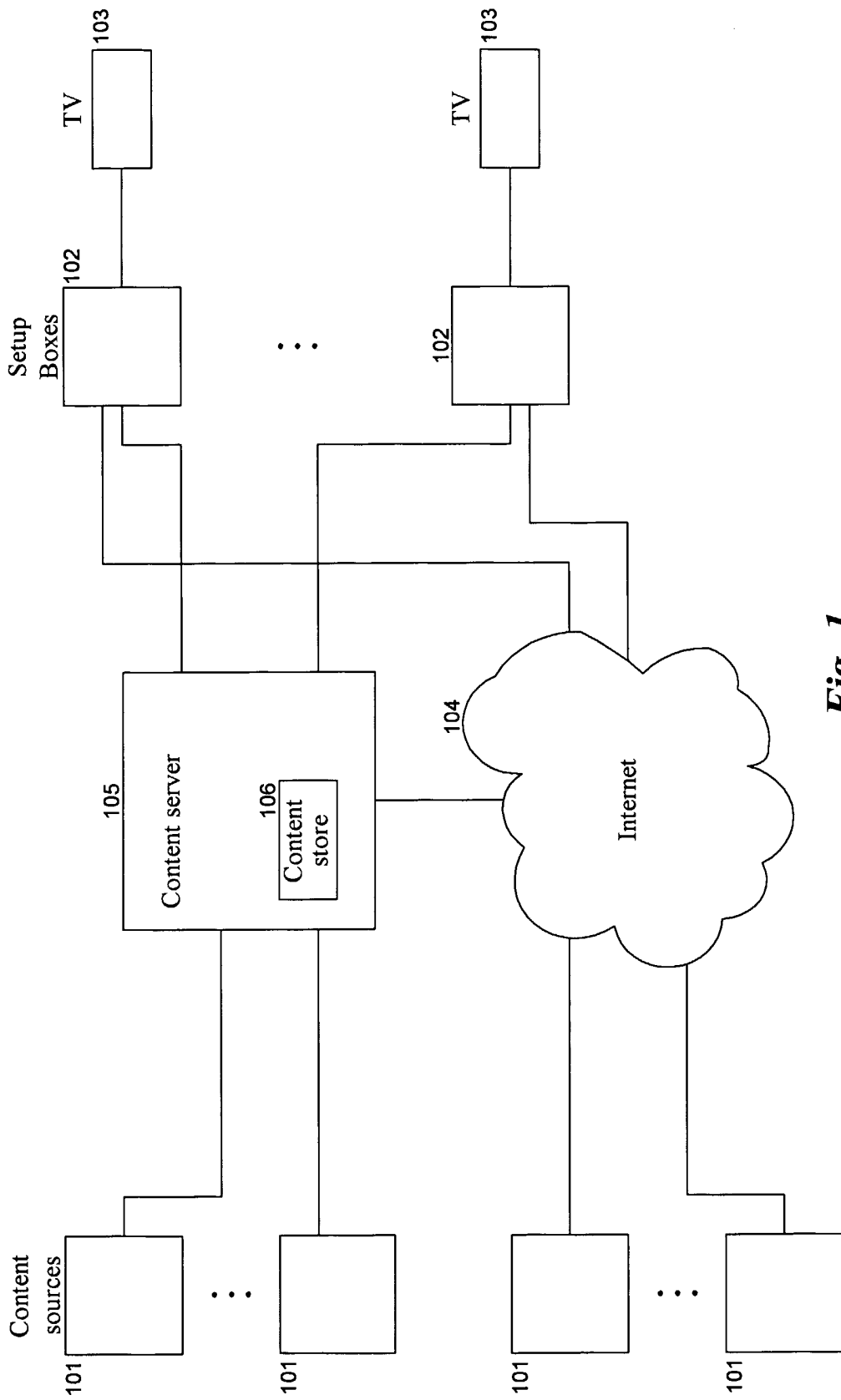
[c78] 78. The method of claim 76 wherein the Internet-based content is a web page.

[c79] 79. The method of claim 76 wherein the selection of the other channel number is indicated by a next channel command.

- [c80] 80. The method of claim 76 wherein the selection of the other channel number is indicated by entry of the other channel number.
- [c81] 81. The method of claim 76 wherein the broadcast content is television content.
- [c82] 82. A method for presenting an electronic program guide, the method comprising:  
providing television programming information;  
providing nontelevision programming information; and  
displaying an electronic program guide that includes a row for each channel of the provided television programming information and at least one row for the nontelevision programming information.
- [c83] 83. The method of claim 82 wherein the nontelevision programming information is Internet-based information.
- [c84] 84. The method of claim 83 wherein different types of Internet-based information are displayed as different rows.
- [c85] 85. The method of claim 82 wherein the nontelevision programming information is on-demand programming information.
- [c86] 86. The method of claim 85 wherein different types of on-demand programming information are displayed as different rows.
- [c87] 87. The method of claim 82 wherein the nontelevision programming information includes Internet-based information and on-demand programming information.

- [c88] 88. The method of claim 87 wherein each row represents a different channel number.
- [c89] 89. A system for presenting an electronic program guide, the comprising:  
means for providing television and nontelelevision programming information; and  
means for displaying an electronic program guide that includes a row for at least one row for the nontelelevision programming information.
- [c90] 90. The system of claim 89 wherein the nontelelevision programming information is Internet-based information.
- [c91] 91. The system of claim 90 wherein different types of Internet-based information are displayed as different rows.
- [c92] 92. The system of claim 89 wherein the nontelelevision programming information is on-demand programming information.
- [c93] 93. The system of claim 92 wherein different types of on-demand programming information are displayed as different rows.
- [c94] 94. The system of claim 89 wherein the nontelelevision programming information includes Internet-based information and on-demand programming information.
- [c95] 95. The system of claim 94 wherein each row represents a different channel number.

[c96] 96. The system of claim 89 wherein the electronic program guide includes row for television programming information.



*Fig. 1*



200

**Electronic Program Guide  
for May 31**

Station	11:30	12:00	12:30	1:00	1:30	2:00
2 KRPC		News		Soap Opera		Sports
3 KBTv		Wheel of Fortune		News	Soap Opera	
4 KNBC	News		Football			
:						
:						
40 HBO		Gone with the Wind				
41 Showtime		Behind the Scenes	Singing in the Rain			
:						
:						

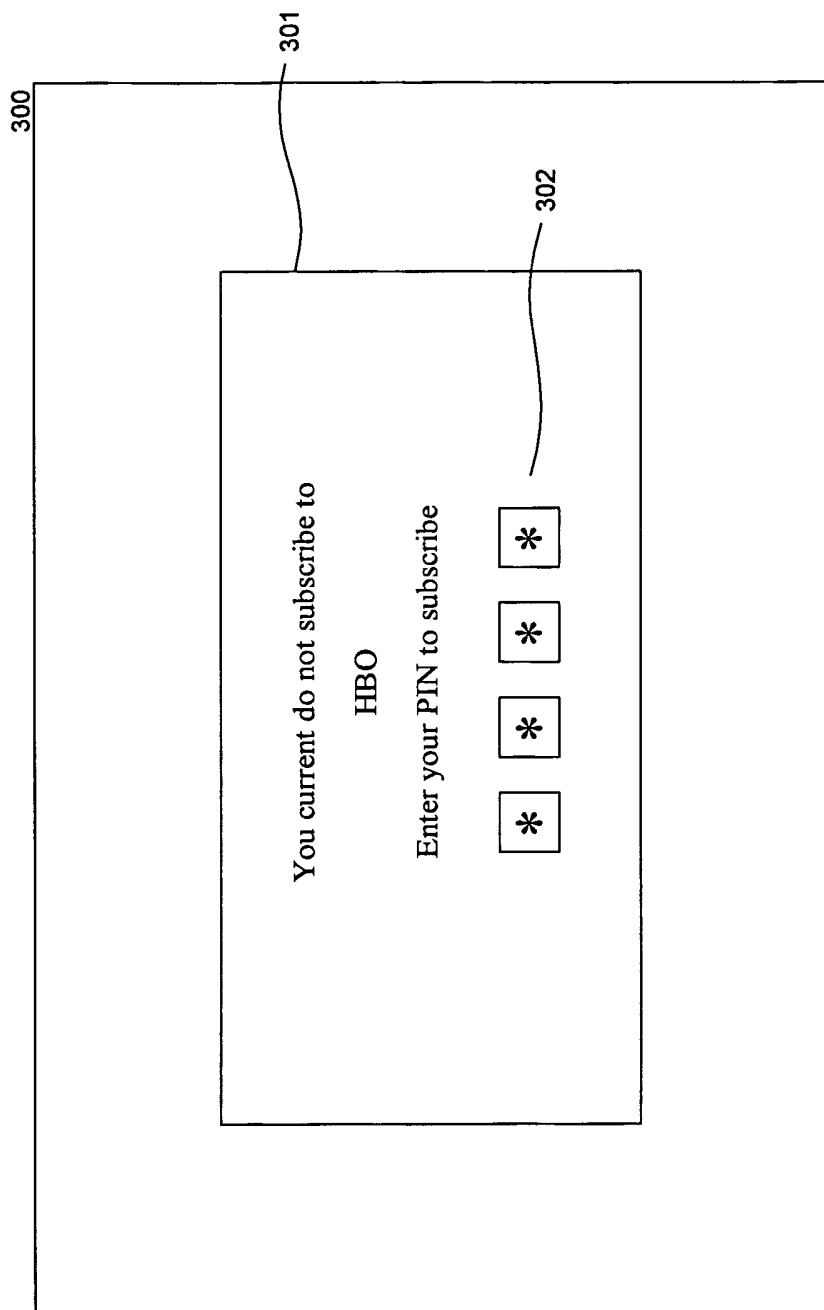
201

202

103

104

**Fig. 2**



*Fig. 3*

4/13

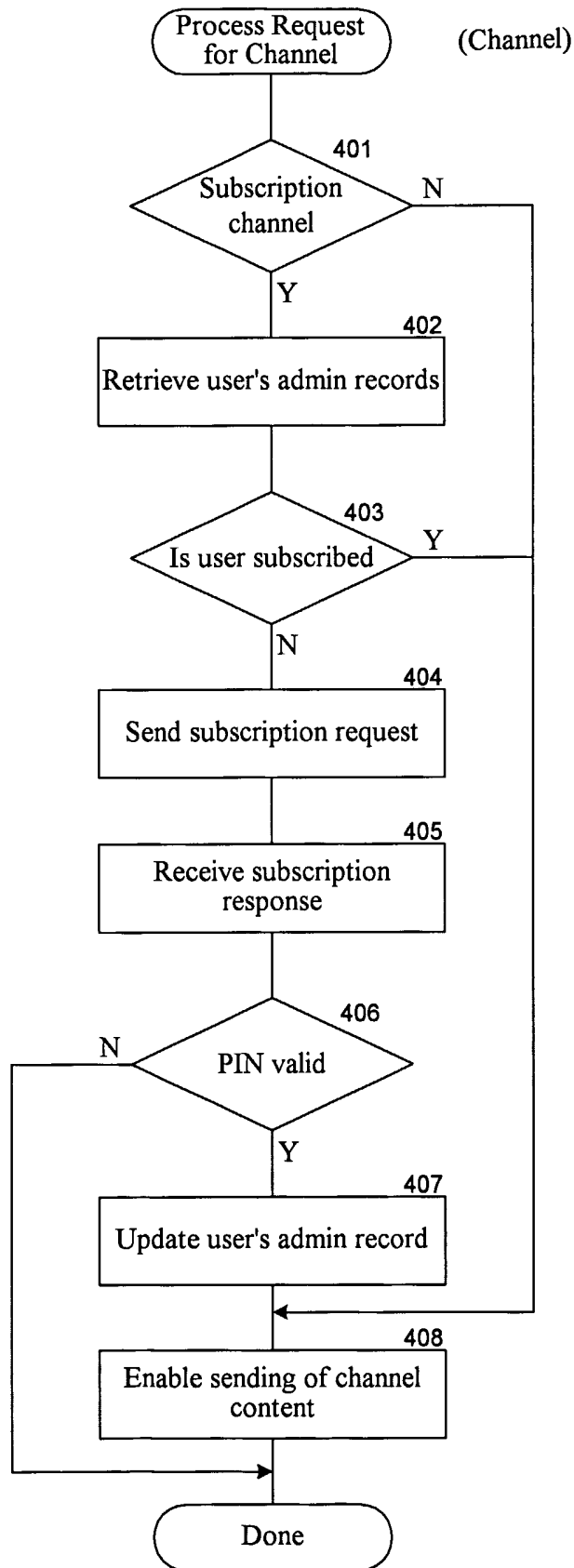
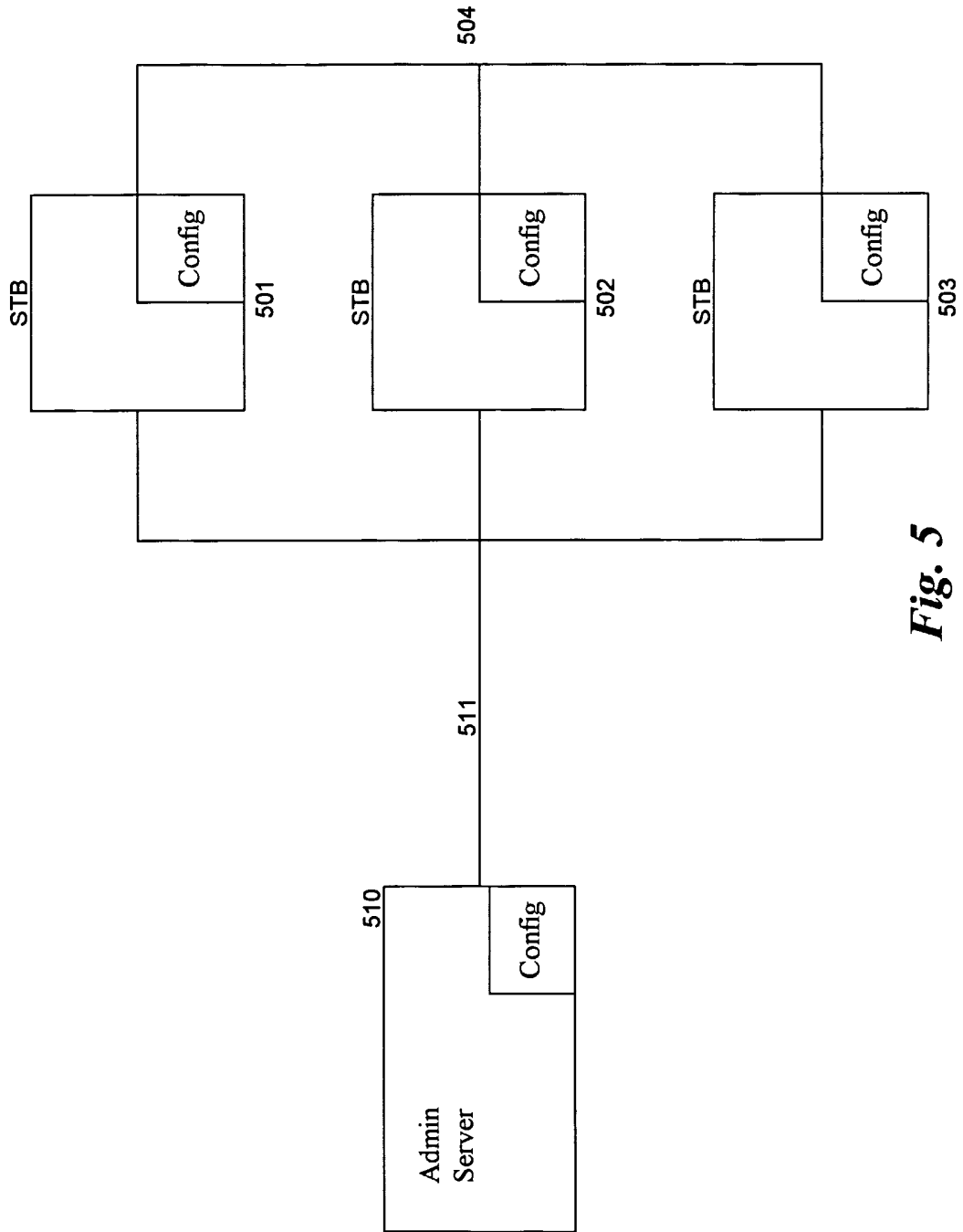
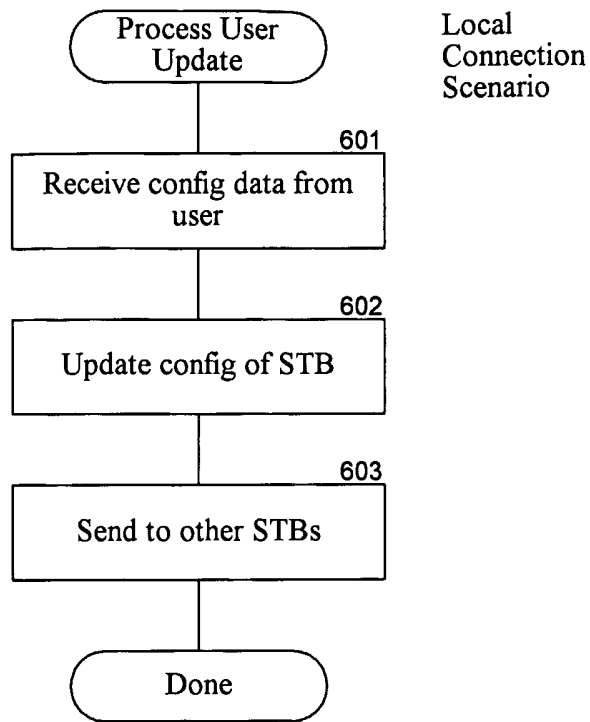


Fig. 4

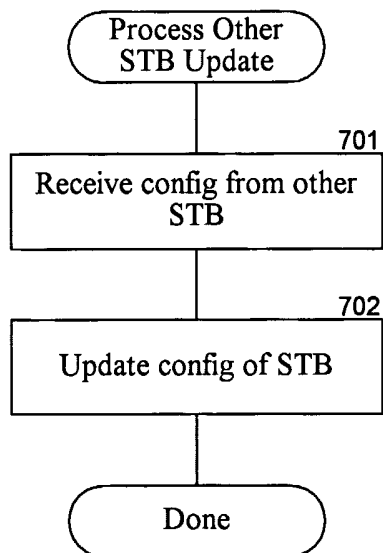


**Fig. 5**

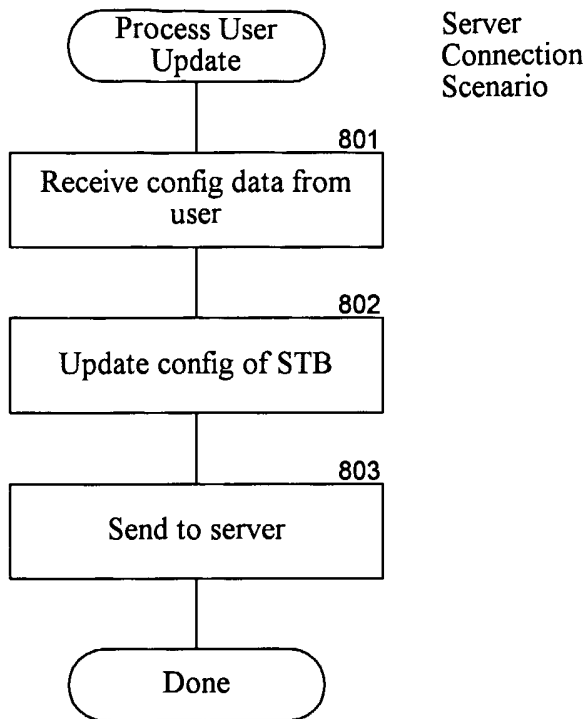
6/13



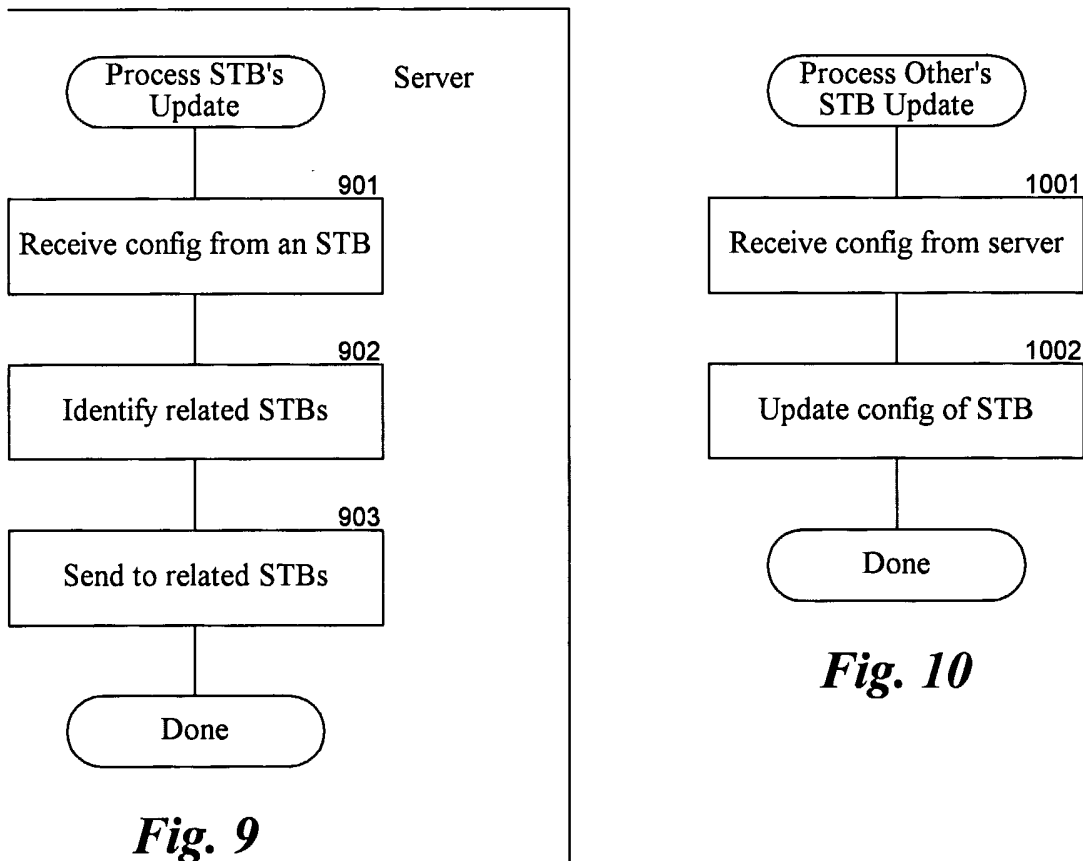
**Fig. 6**



**Fig. 7**

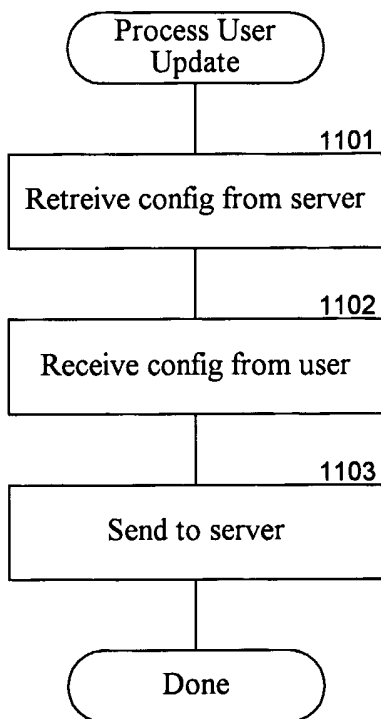


**Fig. 8**

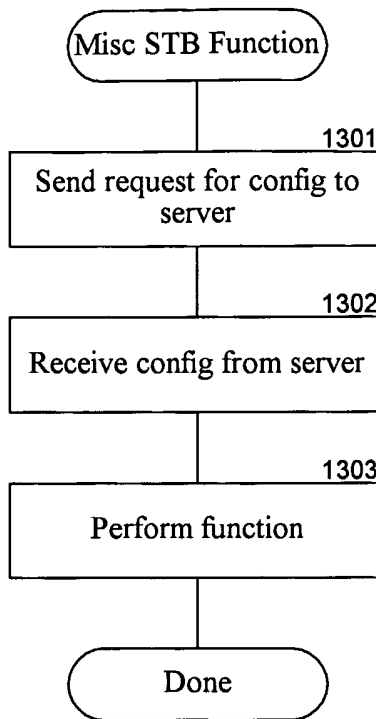


**Fig. 9**

**Fig. 10**



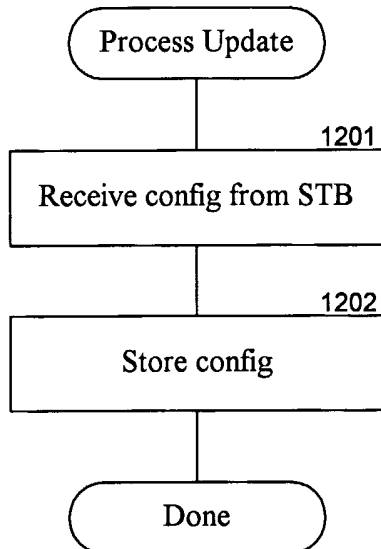
**Fig. 11**



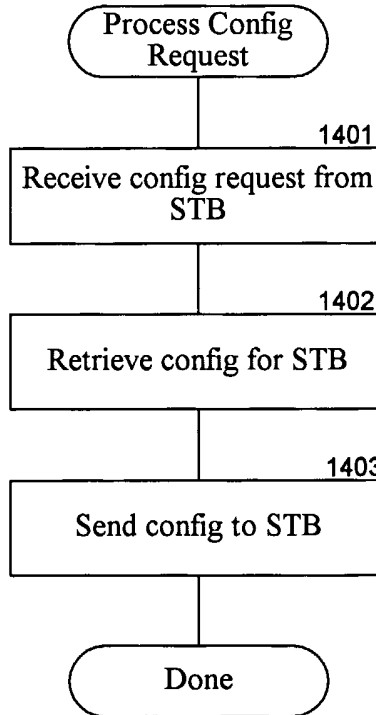
**Fig. 13**

STB

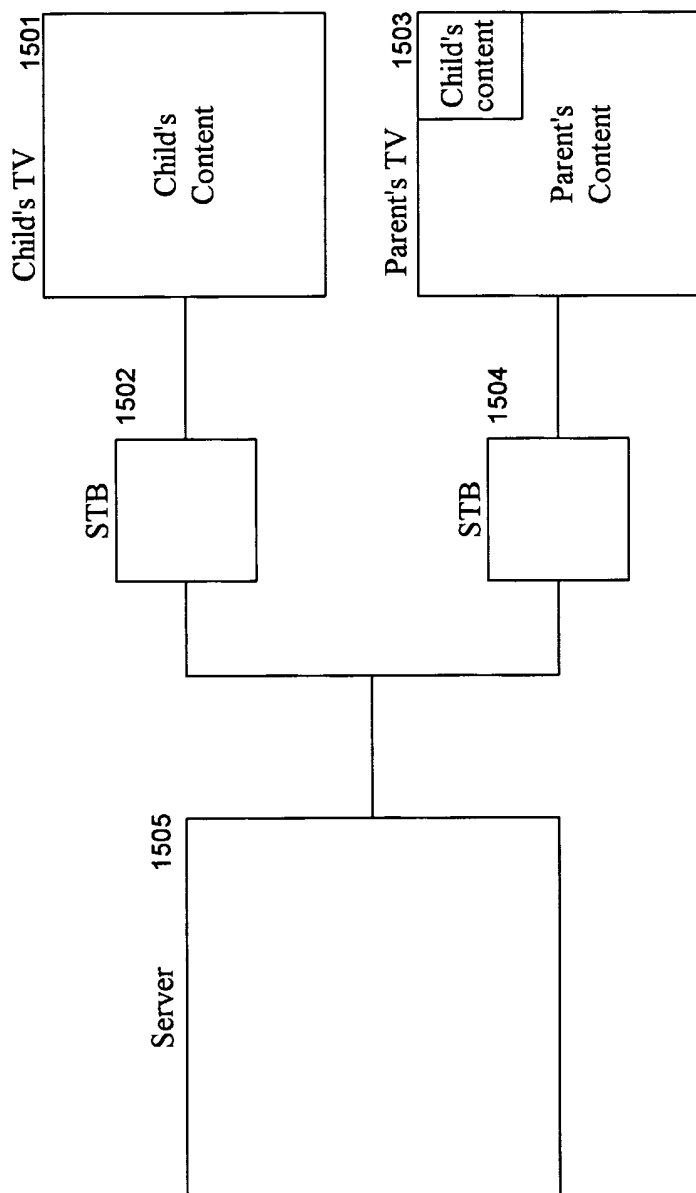
Server



**Fig. 12**

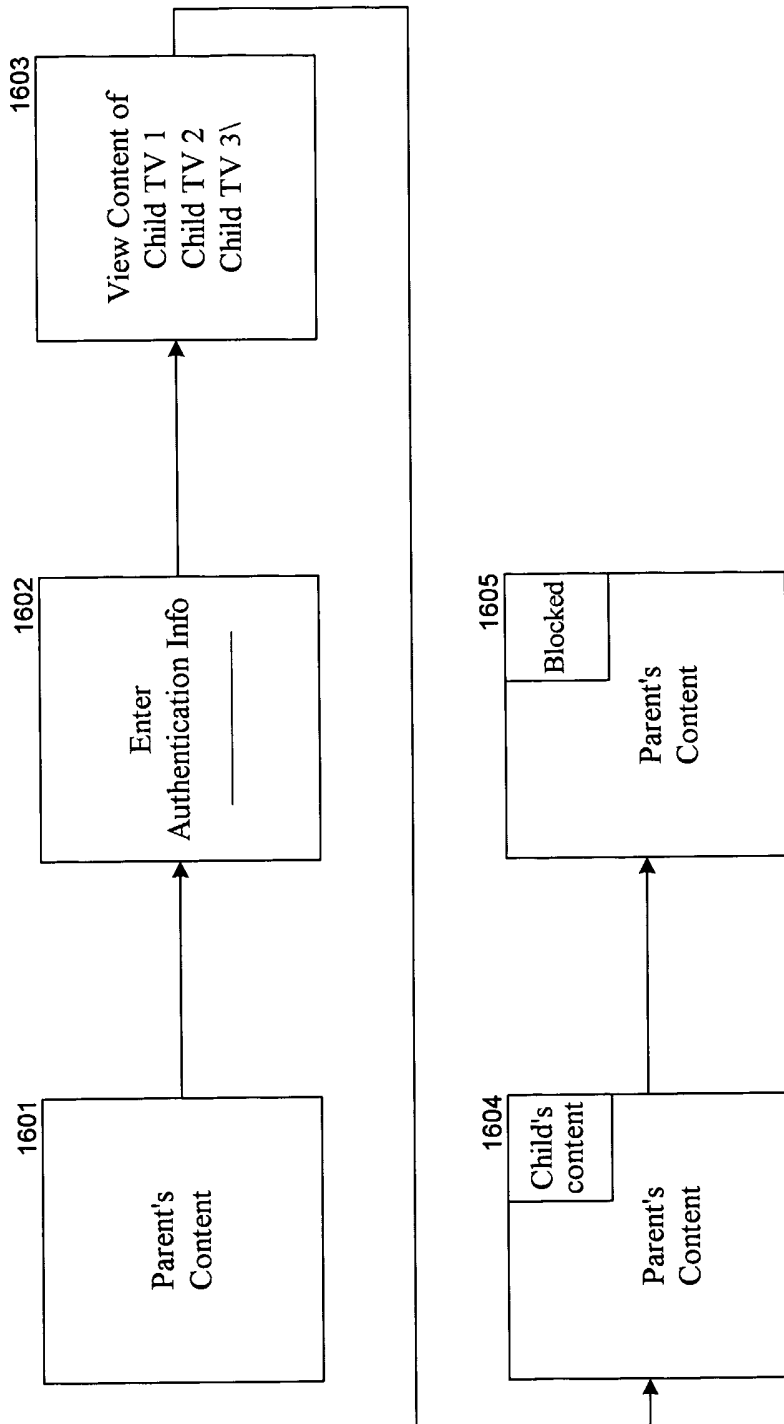


**Fig. 14**



*Fig. 15*





**Fig. 16**

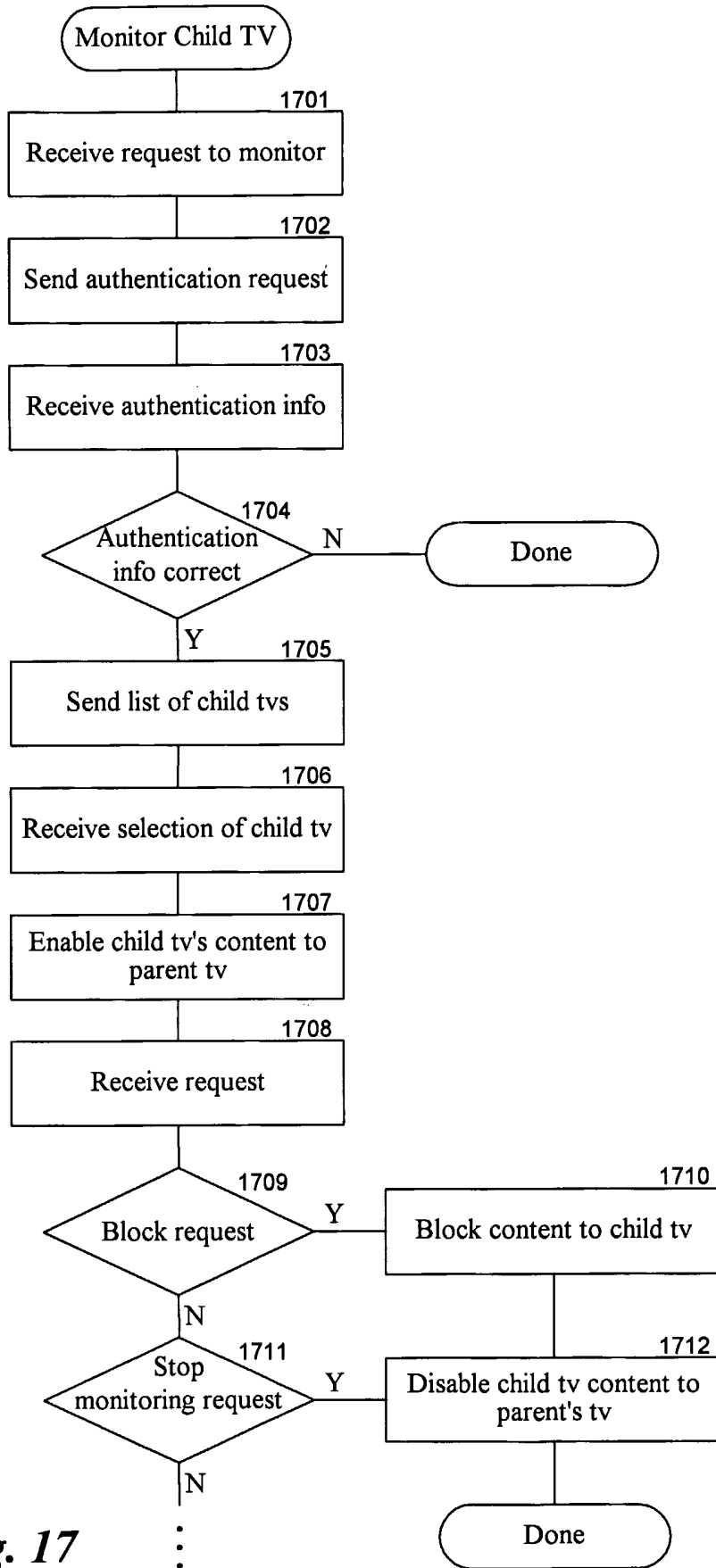


Fig. 17

⋮

Electronic Program Guide for May 31						
Station	11:30	12:00	12:30	1:00	1:30	2:00
2 KRPC		News		Soap Opera		Sports
3 KBTv		Wheel of Fortune		News	Soap Opera	
4 KNBC	News	Football				
• •						
100	News					
101	Sport					
103	Weather					

*Fig. 18*

Local Weather for Washington, D.C.		Monday	Tuesday	Wednesday	Thursday	Friday
Low	65	63	62	60	63	
High	85	84	82	75	84	

**Fig. 19**