

W. M. FULLER.
WATER METER.

No. 104,950.

Patented July 5, 1870.

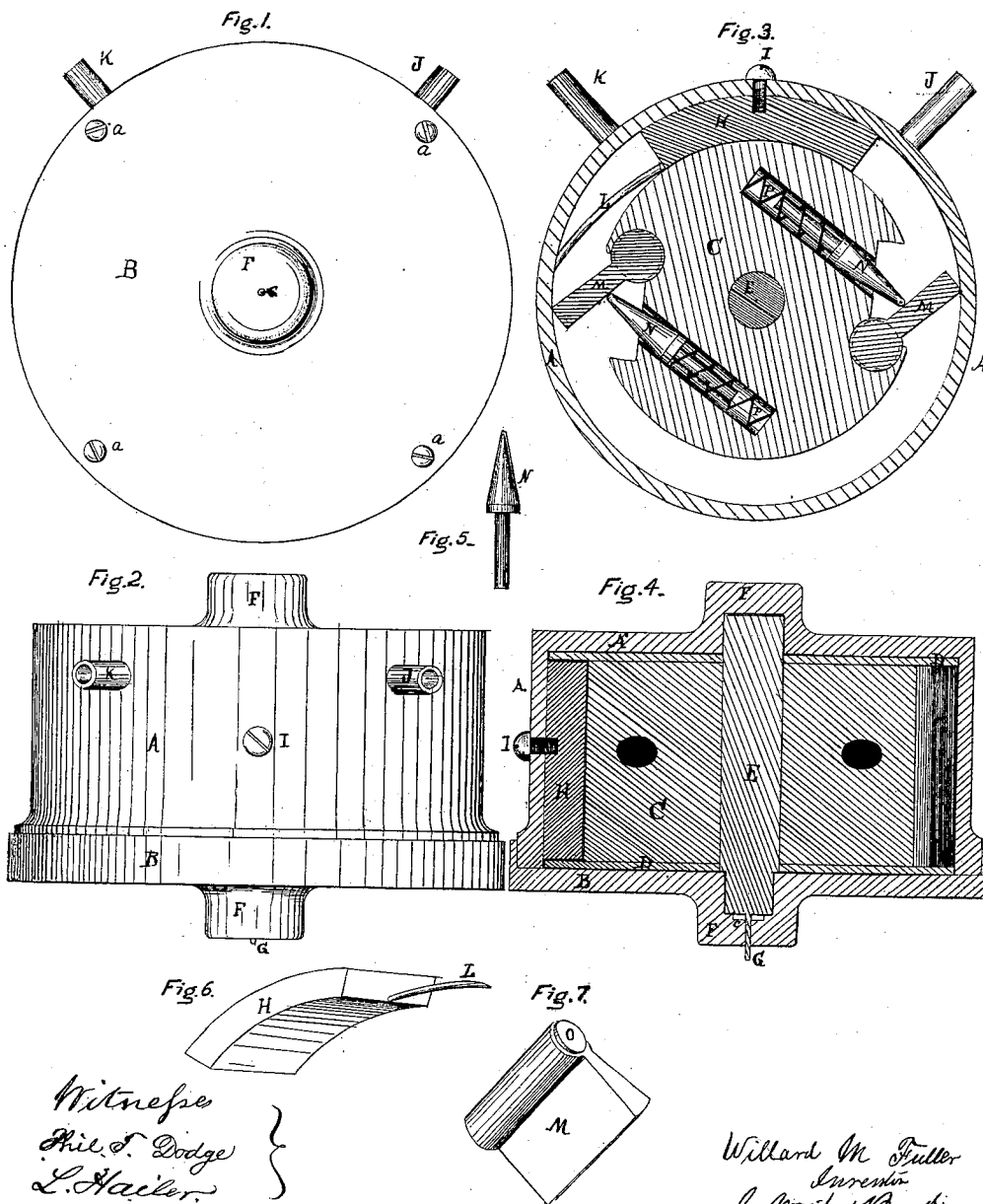

Witnesses
 Phil. T. Dodge
 L. Hailer.

Willard M. Fuller
 Inventor
 by West & Bond
 his atty

United States Patent Office.

WILLARD M. FULLER, OF NEW YORK, N. Y.

Letters Patent No. 104,950, dated July 5, 1870.

IMPROVEMENT IN WATER-METERS.

The Schedule referred to in these Letters Patent and making part of the same.

To all whom it may concern :

Be it known that I, WILLARD M. FULLER, of the city and county of New York, in the State of New York, have invented certain new and useful Improvements in Water-Meters, of which the following is a specification, reference being had to the accompanying drawing making a part thereof, in which—

Figure 1 represents a top or plan view;

Figure 2, a side elevation;

Figure 3 a top view with the cap B and plate D removed;

Figure 4, vertical section; and

Figures 5, 6, and 7, views of details, detached.

Like letters refer to the same parts in all of the figures.

My invention relates to that class of meters which has folding wings applied to an interior cylinder, rotating within an exterior case, so that the wings will cross the space between the two, and measure the quantity of water passing from the induction to the eduction-pipe, and its nature consists in an improved packing, and in the several combinations hereinafter more fully described and claimed as new.

To enable others skilled in the art to make and use my improved meter, I will now describe the construction and operation of the same.

The case A A' may be made of a single piece, as shown, but in practice I prefer to make the end A' of a separate piece, the same as the end or head B, and secure both to the cylinder or case A, by means of flanges or bolts, or by screws.

I make the interior dimensions for a five-eighths service-pipe eight inches in diameter and four inches in length, and the diameter of the interior cylinder, C, five inches.

The case A B may be made wholly of brass, or it may be made of cast-iron, and be lined with brass, after being bored and turned, or it may be cast and lined with Babbitt or other similar metal, and then be bored and turned.

The interior cylinder C is made with its disks or flanges D to fill the case endwise, and is made solid or hollow, as may be desired, and is provided with suitable recesses to receive the folding wings, as shown at fig. 3.

The wings M are pivoted to the cylinder C, and are of the same in length as the cylinder, and are of sufficient width to cross the space between this cylinder and the case, at a slight angle or tangentially, so as to insure the pressure of the wings against the case, to compensate for all wear, and avoid packing.

In order to insure the prompt action of these wings, I place springs beneath them in the recesses of the cylinder. The springs shown are made of a bolt, N, provided with a shoulder resting upon a helical or

coiled spring, P, and both are inserted in a hole drilled into the cylinder, but a piece of rubber may be inserted in the same way, and act directly upon the wings, or any other suitable spring may be applied.

In the space between the cylinder C and the case, I insert a segment, H, which is made to fill the space, and is a little longer than the width of the recess into which the wings fold.

On one side or end of this segment I place a bar or rod, L, which is connected with it at the inner surface, and extending outward, in a curved form, rests against the case, as shown at fig. 3. This arm may be cast with the segment, and be made of any desired width, but a small bar or rod will be sufficient, as its only function is to fold the wings. The end of the segment may be beveled off, so as to accomplish the same purpose, and, in that event, the rod L can be dispensed with.

A similar arrangement may be made at the opposite end of the segment for easing the wings down, but it is unnecessary.

This segment is stationary, and is secured to the case by the bolt I, or by any other suitable means.

One or both of the plates D of them may be made with and a part of the cylinder C, but I prefer to make them of separate plates or disks, and screw them to the ends of the cylinder. They are made of the same diameter as the interior of the case A, and revolve with the cylinder C, so that there is less friction in the movement and at the ends of the wings, and any water that may get between them and the case will act as a lubricator; and I contemplate making small grooves in these plates, or in the case, for the admission of water for that purpose and for counter-pressure.

Short journals, O, are made on the ends of the wings, which are inserted into holes fitting them in these plates, and passing about half way through the plates.

The shaft E is journaled at F, and fully inclosed, at one end, and nearly so at the other, as shown at fig. 4.

One end terminates with a small rod, G, which passes through the case, and by which any suitable registering device is operated.

The end of the shaft, to which the rod or stem G is attached and is packed, has the same journal bearing as the opposite end, but the box or bearing is drilled beyond the end for the shaft, with a hole about one half the size of the journal-bearing, as shown at C, fig. 4, into which a piece of rubber is inserted, so as to fill it. The stem G is driven through this rubber, so as to form a complete packing for it.

By placing this packing in a separate recess it is not subjected to any wear, and any water that may get to the end of the shaft will only press upon the

packing so as to make it adhere closer to the stem, and by reason of this packing I am enabled to use any convenient register outside of the meter, as no water can possibly get into it.

In operation, the water enters at pipe J, and, pressing against the wing, causes the cylinder C to rotate. Before the first wing reaches the incline L the opposite or second one has passed the induction pipe, where the first one commences to fold as soon as this movement takes place, and the water passes out at the induction pipe K, and so on, making the movement continuous. The only point to be observed in locating the pipes is that they must be so located that one wing will pass the induction pipe before the opposite one commences discharging when only two wings are used. By applying more wings the pipes may be located opposite to each other. By extending the shaft E through, this device can be used as a water-engine.

Having thus fully described my improved meter, What I claim as new, and desire to secure by Letters Patent, is—

1. The combination of the wings M, springs N P, with the case A B, cylinder C, and segment H, substantially as set forth.

2. The combination and arrangement of the case A B, cylinder C, plates or flanges D, wings M, and segment H, with the pipes J and K, substantially as and for the purposes specified.

3. The flexible packing e, when located in a separate recess in the journal-bearings at the end of the shaft, substantially as and for the purposes described.

WILLARD M. FULLER.

Witnesses:

WM. H. SMITH,

A. H. NONES.