

A. D. Clark,

Indicator.

No. 105,304.

Patented July 12, 1870.

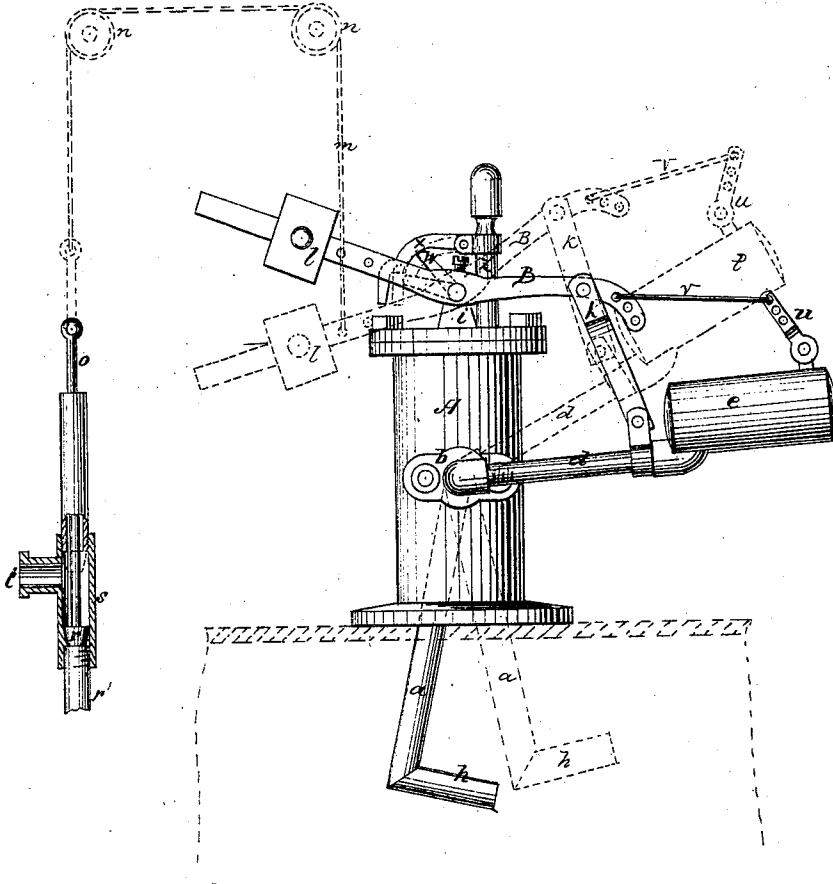

Witnesses:

Victor Hagmann

C. A. Pettit

Inventor:

A. D. Clark
per *Munn & Co.*
Attorneys.

United States Patent Office.

ALFRED D. CLARK, OF GREENFIELD, OHIO.

Letters Patent No. 105,304, dated July 12, 1870.

AUTOMATIC FEEDER AND INDICATOR FOR STEAM-BOILERS.

The Schedule referred to in these Letters Patent and making part of the same.

To all whom it may concern:

Be it known that I, ALFRED D. CLARK, of Greenfield, in the county of Highland and State of Ohio, have invented a new and Improved Automatic Feeder and Indicator for Steam-Boilers; and I do hereby declare that the following is a full, clear, and exact description of the same, reference being had to the accompanying drawing making a part of this specification, in which the figure is a side elevation.

This invention has for its object to automatically alternately introduce and cut off a supply of water to a steam-boiler, according to the needs of the case, and also to indicate by a whistle or bell every such introduction and shutting off.

The invention principally consists in the combination, with an oscillating pipe, whose fulcrum is in the dome or other fixed part of a steam-boiler, and extends within the same, of a vessel fixed on the upper and outer extremity of said pipe, which vessel is made to vibrate by means of its alternate filling with water from the boiler through said oscillating pipe, under steam-pressure, and the emptying of the vessel, owing to the gravity of its contents, such vibration working the valve of a force-pump or steam-injector, in such a manner as to produce a flow of water into the boiler, or shut off the same, as required.

The invention also consists in the combination of the vibrating arm, to which the said vessel is attached, with a whistle-valve or bell, in such manner as to sound an indication of both the entrance and shutting off of water, with respect to the boiler.

In the drawing—

A is a dome, to be attached to a steam-boiler.

a is a vibrating-pipe, opening at its upper end into another pipe placed crosswise of the inside of the dome A, in such a manner that it may rock therein, passing out through a stuffing-box, b, in the side of the dome, and connected by an elbow, c, with a pipe, d, which opens into a cylindrical vessel, e.

The pipe a has an elbow at its lower end, by which the branch h is attached to it.

B is a lever, pivoted to a stand, i, on the top of the dome.

A rod, k, jointed at both ends, connects the pipe d with the adjacent extremity of the lever B, on whose opposite extremity is an adjustable weight, l, heavy enough to keep the vessel e poised at its highest position when empty.

This position, shown in dotted lines, is the one the apparatus assumes when there is no steam in the boiler.

When the fire has been kindled, however, and two or three pounds of steam generated, the pressure of the same forces water into the branch h, and through the pipes a and d into the vessel e, which is of such capacity that, when filled with water, it falls to its lowest position, raising the counter-weight.

Near the latter, a cord, m, is tied to the lever B,

which cord runs over sheaves n n, and attaches at its other extremity to the vertical stem o of the valve r in the cylinder s, connected with the force-pump by a pipe, r.

The raising of the weighted end of the lever B lowers the valve r, and prevents water from flowing to the force-pump.

Its supply being thus cut off, the water in the boiler falls as steam is made, until it lays bare a portion of the mouth of the branch h.

As soon as this takes place, the water in the vessel e runs down into the boiler, and its place is supplied by steam from the latter.

The vessel e, thus lightened, is raised by the counter-weight, and the sinking of the latter elevates the valve r above the nozzle t, and thus allows water to flow through the latter into the force-pump.

The water having risen in the boiler, so as to cover the mouth of the branch h, the vessel e is again filled with water by steam-pressure, as before, and sinks again.

As it falls, the arm u, that operates a valve in an orifice leading out of the vessel e, is drawn downward by a rod, v, connecting it with the lever B, opens its valve, and allows the steam in the vessel to escape.

The rising of the vessel once more shuts off the water-supply from the boiler, and thus the alternation goes on, the limits of variation in the altitude of the water in the boiler being determined by the length of the branch h, the variation being greater the longer the pipe.

An arm, w, projects from the rock-shaft, to which the vibrating lever B is attached, and bears against the under side of the lever z, to which a whistle-valve is secured within the hollow stem z.

As the lever B vibrates, whether from the rise or fall of the vessel e, the arm w lifts and lowers the lever z, so as to cause the whistle to sound once and then cease.

The regular occurrence of the whistles shows that the apparatus is working properly. Their cessation indicates that something is wrong.

Having thus described my invention,

What I claim as new, and desire to secure by Letters Patent, is—

1. The combination of the vibrating vessel e with the oscillating pipe d a h, whose fulcrum is in the dome A, or other fixed part of the boiler, and which extends within the same, substantially in the manner and for the purpose described.

2. The combination of the vibrating lever B and arm w with the whistle-valve arm z, in the manner and for the purpose described.

ALFRED D. CLARK.

Witnesses:

CHAS. A. PETTIT,
SOLON C. KEMON.