



US007768117B2

(12) **United States Patent**  
**Haba et al.**

(10) **Patent No.:** **US 7,768,117 B2**  
(45) **Date of Patent:** **Aug. 3, 2010**

(54) **MICROELECTRONIC PACKAGE HAVING INTERCONNECTED REDISTRIBUTION PATHS**

(75) Inventors: **Belgacem Haba**, Saratoga, CA (US); **Richard Dewitt Crisp**, Castro Valley, CA (US); **Masud Beroz**, San Jose, CA (US)

(73) Assignee: **Tessera, Inc.**, San Jose, CA (US)

(\* ) Notice: Subject to any disclaimer, the term of this patent is extended or adjusted under 35 U.S.C. 154(b) by 103 days.

(21) Appl. No.: **11/809,214**

(22) Filed: **May 30, 2007**

(65) **Prior Publication Data**

US 2008/0296748 A1 Dec. 4, 2008

(51) **Int. Cl.**

**H01L 23/48** (2006.01)  
**H01L 23/02** (2006.01)

(52) **U.S. Cl.** ..... **257/691**; 257/E23.079; 257/E23.151; 257/686; 257/678; 257/741; 257/773; 257/698; 257/203; 257/208; 257/207; 257/693; 257/664

(58) **Field of Classification Search** ..... 257/686, 257/692, 741, 773, E23.079, E23.151, 691, 257/698, 203, 211, 207, 693, 664  
See application file for complete search history.

(56) **References Cited**

**U.S. PATENT DOCUMENTS**

3,579,056 A \* 5/1971 TeVelde et al. .... 257/506

5,570,504 A *	11/1996	DiStefano et al. ....	29/830
6,376,904 B1	4/2002	Haba et al.	
2003/0153122 A1 *	8/2003	Brooks .....	438/107
2006/0166404 A1 *	7/2006	Corisis et al. ....	438/109
2007/0035036 A1 *	2/2007	Sota et al. ....	257/784
2008/0250628 A1 *	10/2008	Maeda et al. ....	29/602.1
2008/0265389 A1 *	10/2008	Hsu et al. ....	257/686
2008/0311702 A1 *	12/2008	Wark .....	438/109

\* cited by examiner

*Primary Examiner*—Alexander O Williams

(74) *Attorney, Agent, or Firm*—Lerner, David, Littenberg, Krumholz & Mentlik, LLP

(57) **ABSTRACT**

A microelectronic unit has a structure including a microelectronic element such as a semiconductor chip with a first contact disposed remote from the periphery of the structure. The unit further includes first and second redistribution conductive pads disposed near a periphery of the structure and a conductive path incorporating first and second conductors extending toward the first contact, these conductors being connected to one another adjacent the first contact. The conductive path is connected to the first contact, and can provide signal routing from the periphery of the unit to the contact without the need for long stubs. A package may include a plurality of such units, which may be stacked on one another with the redistribution conductive pads of the various units connected to one another.

**18 Claims, 14 Drawing Sheets**

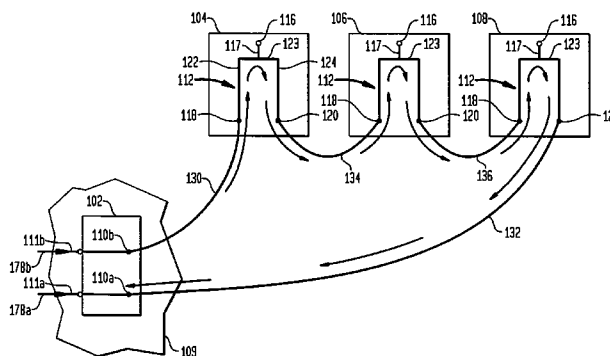
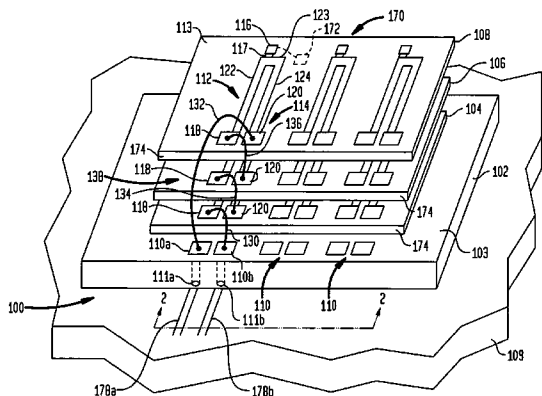

FIG. 1

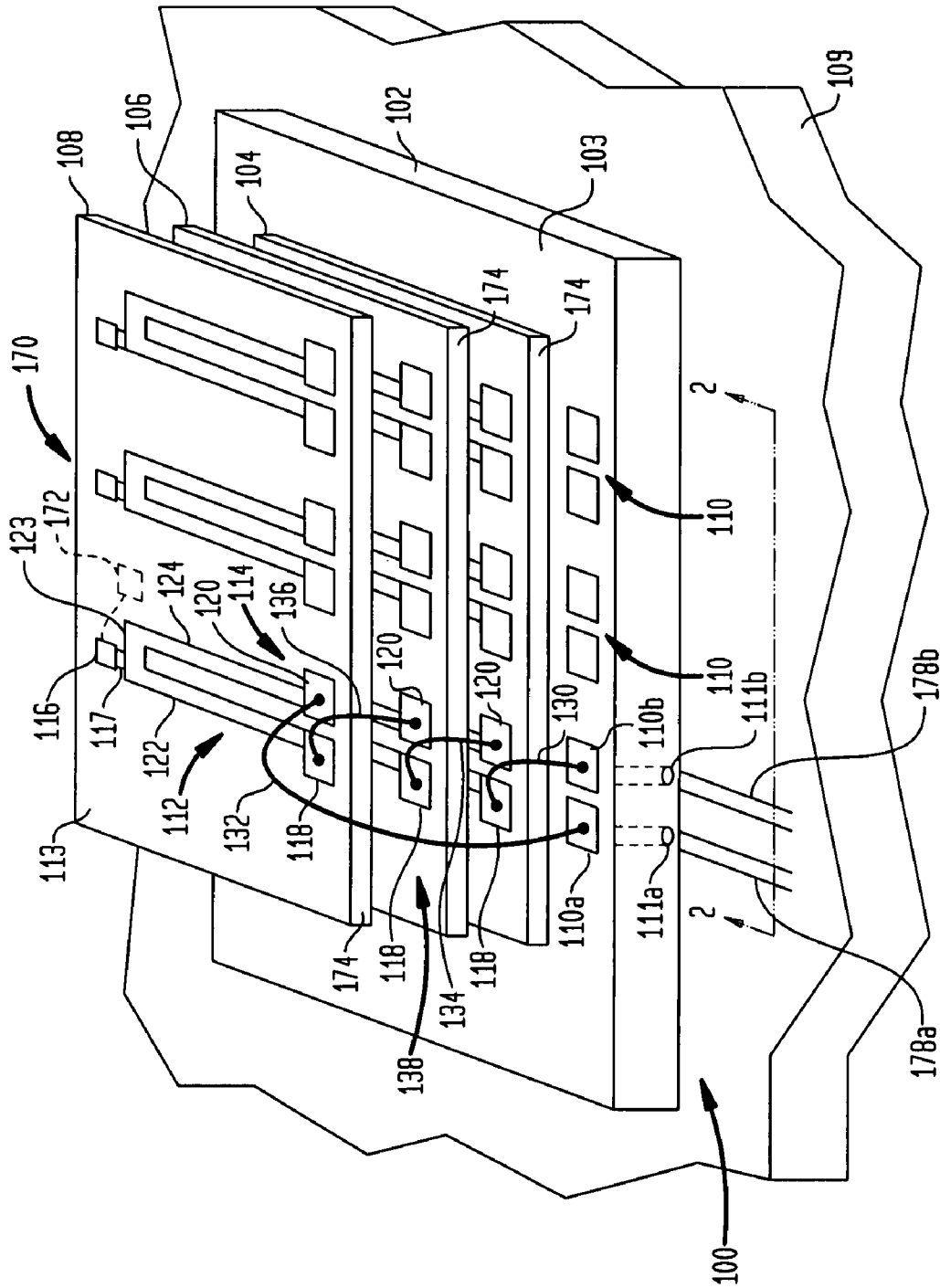



FIG. 3

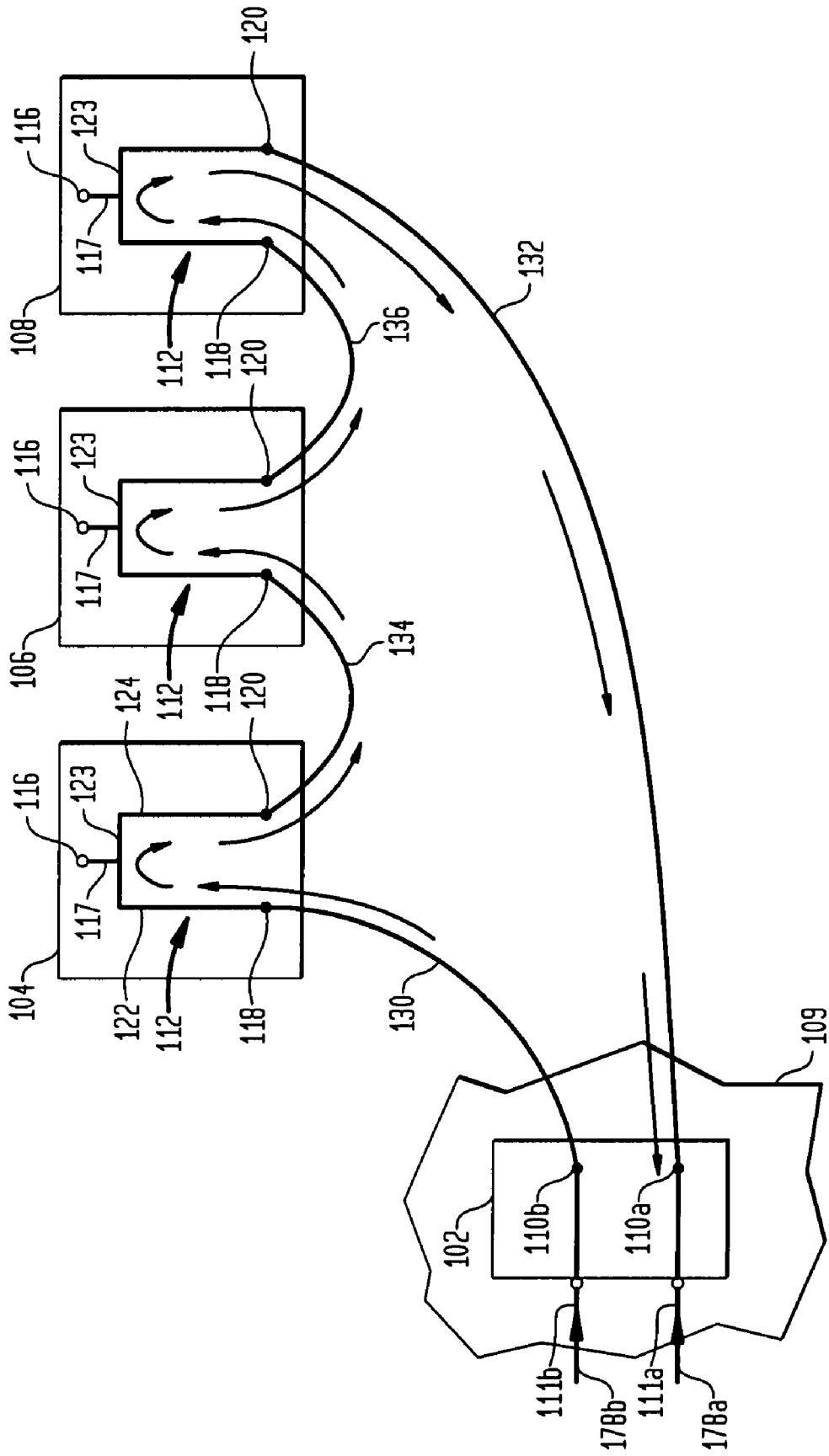



FIG. 5

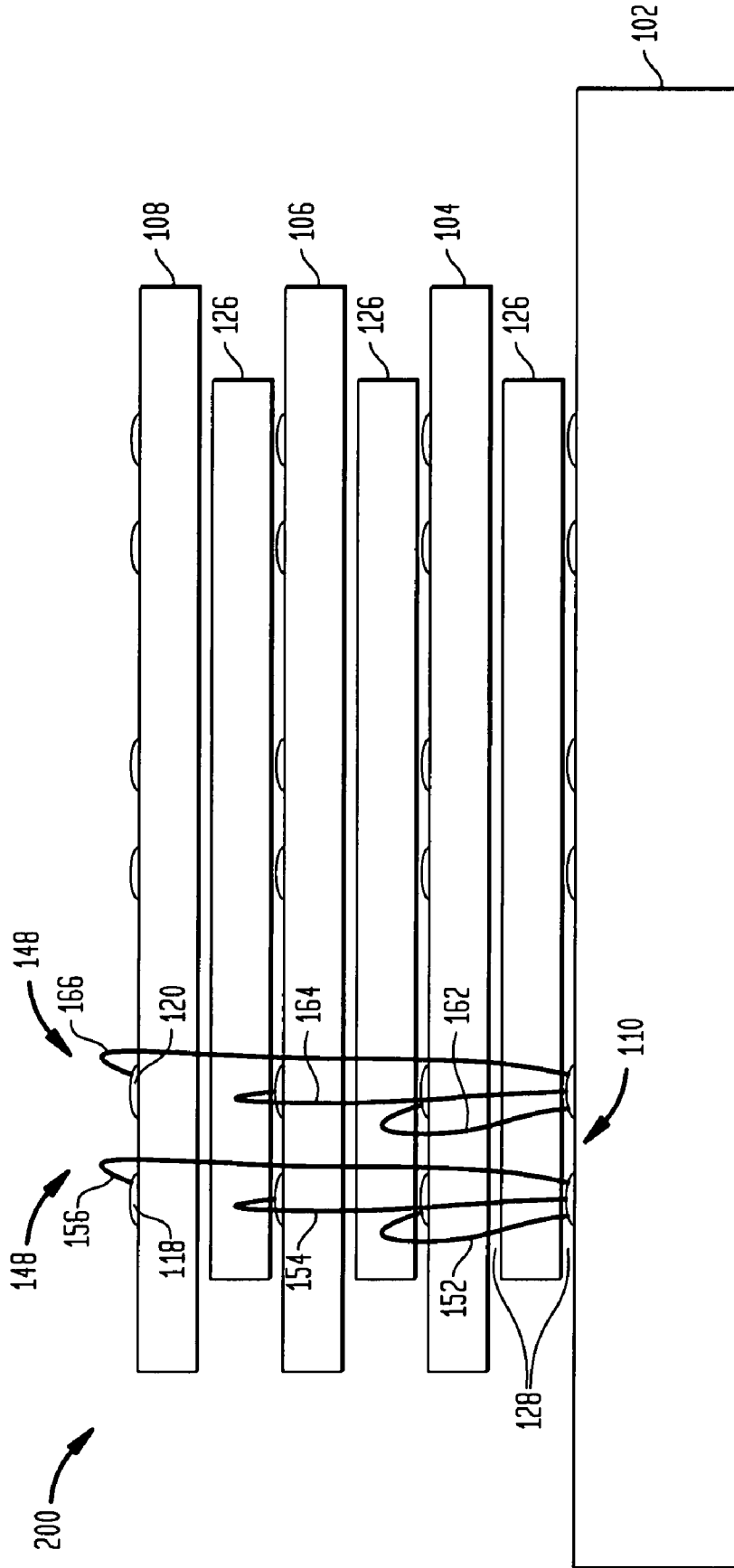

FIG. 6

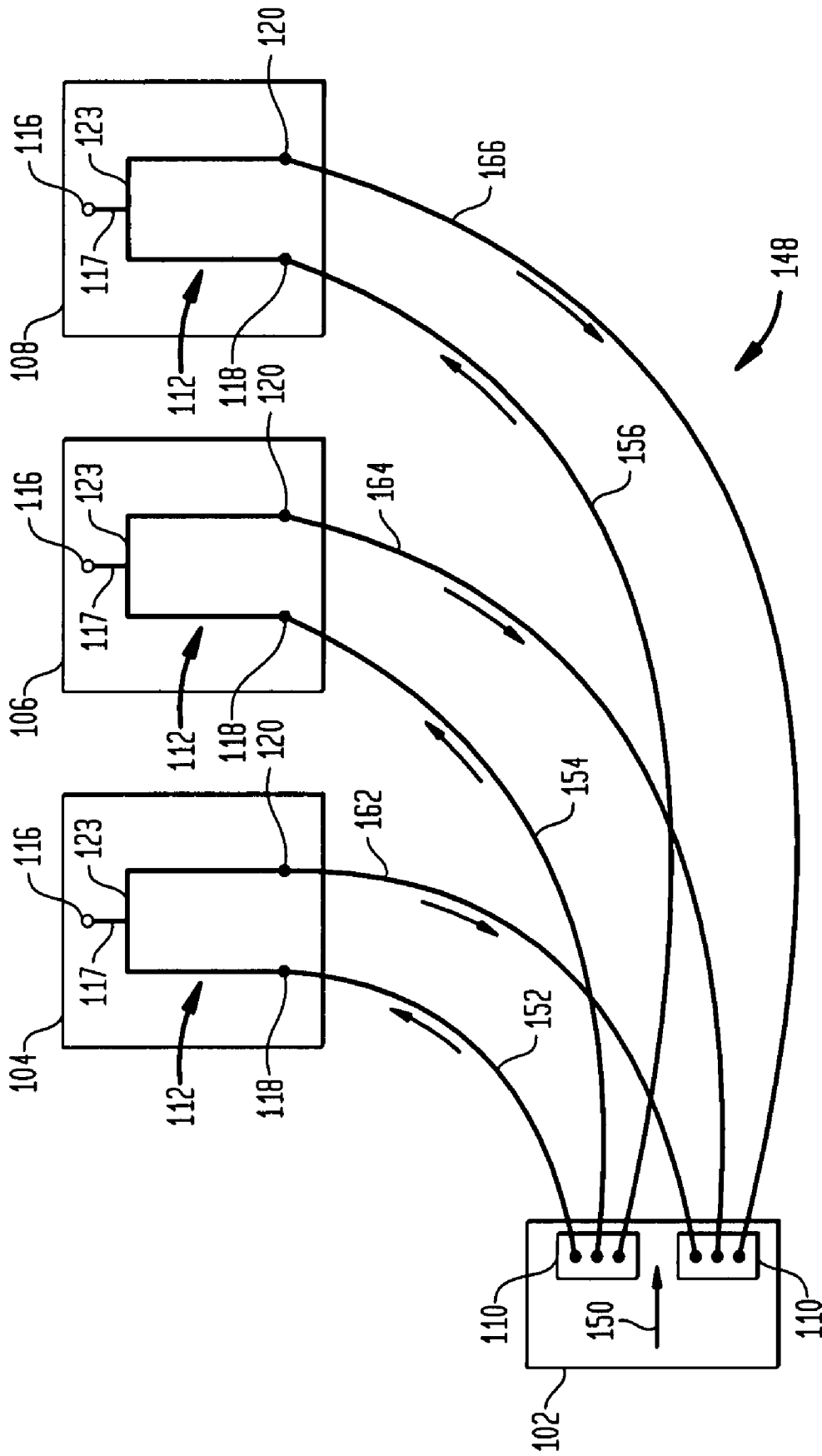

FIG. 7A

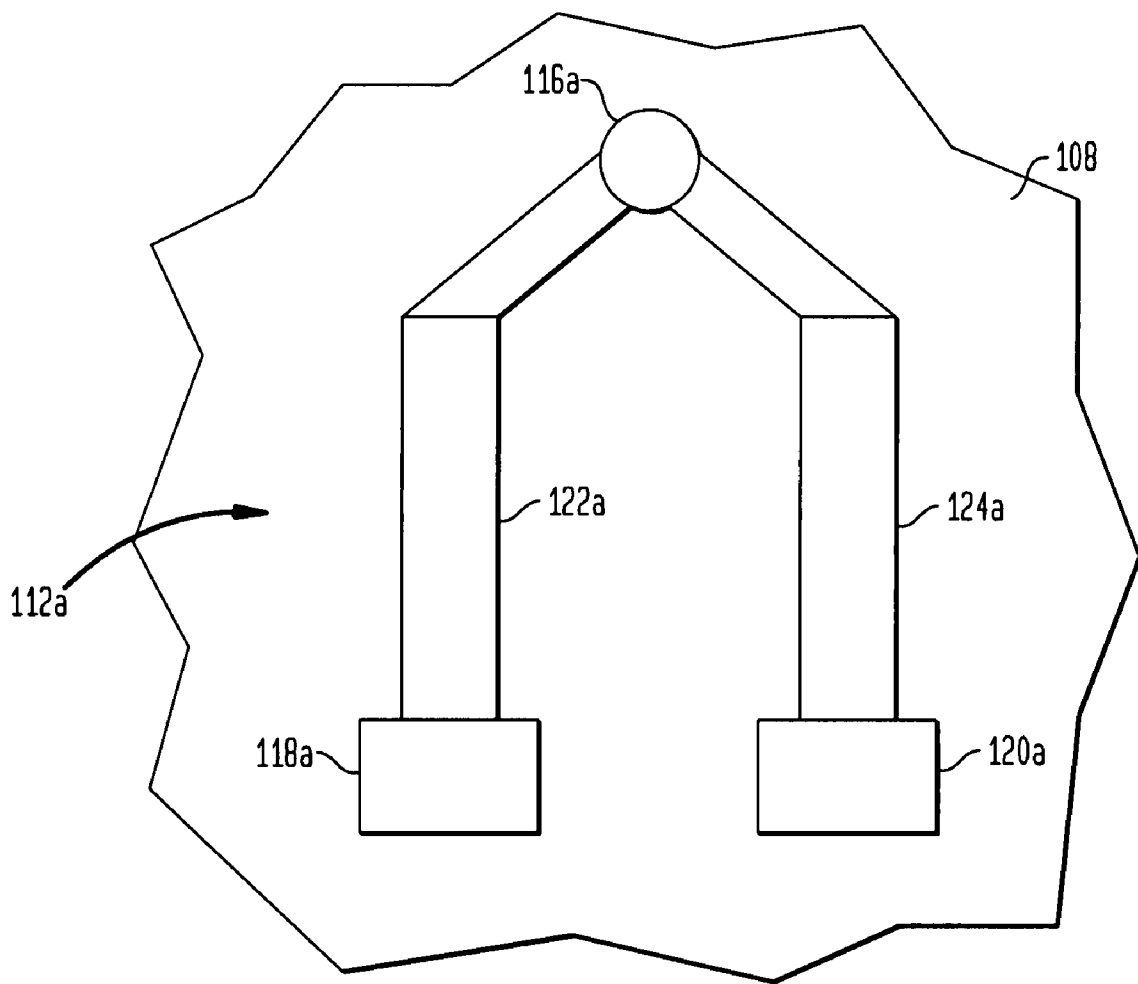

FIG. 7B

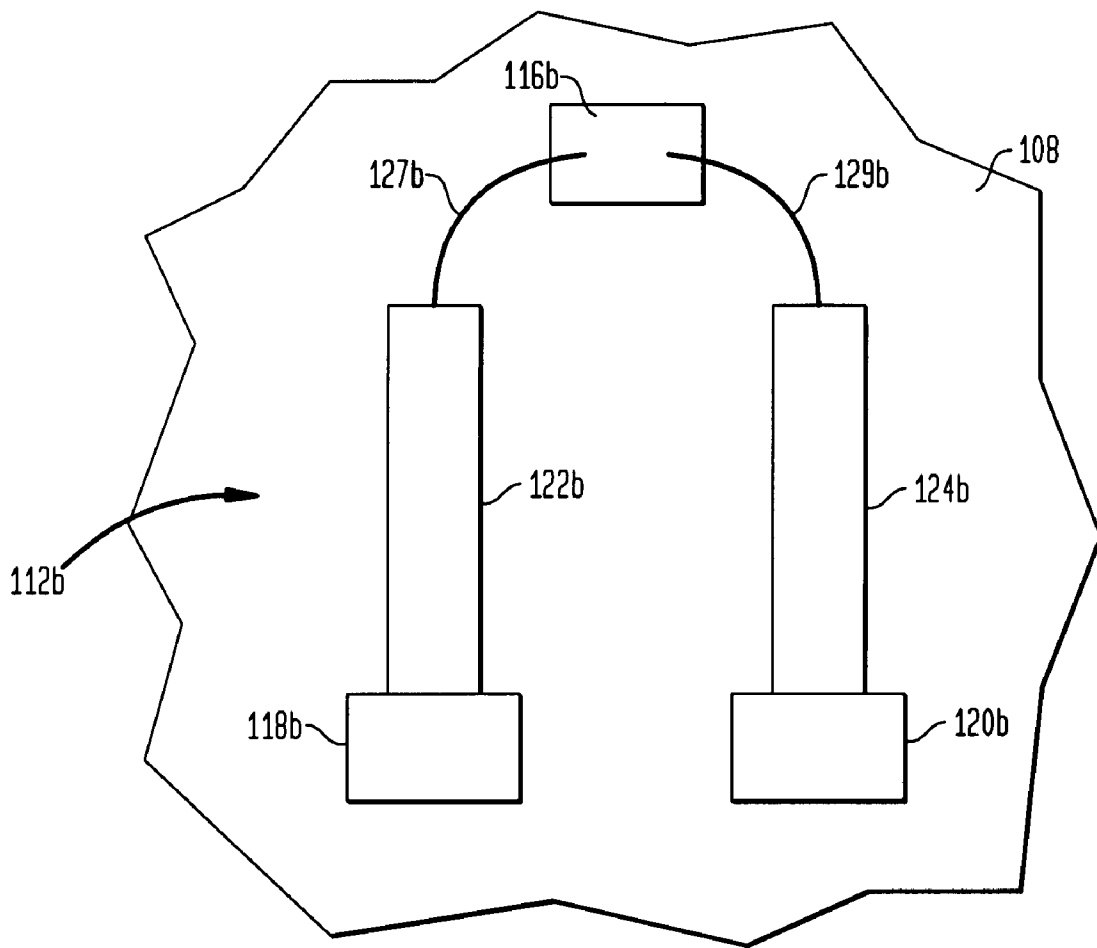

FIG. 7C

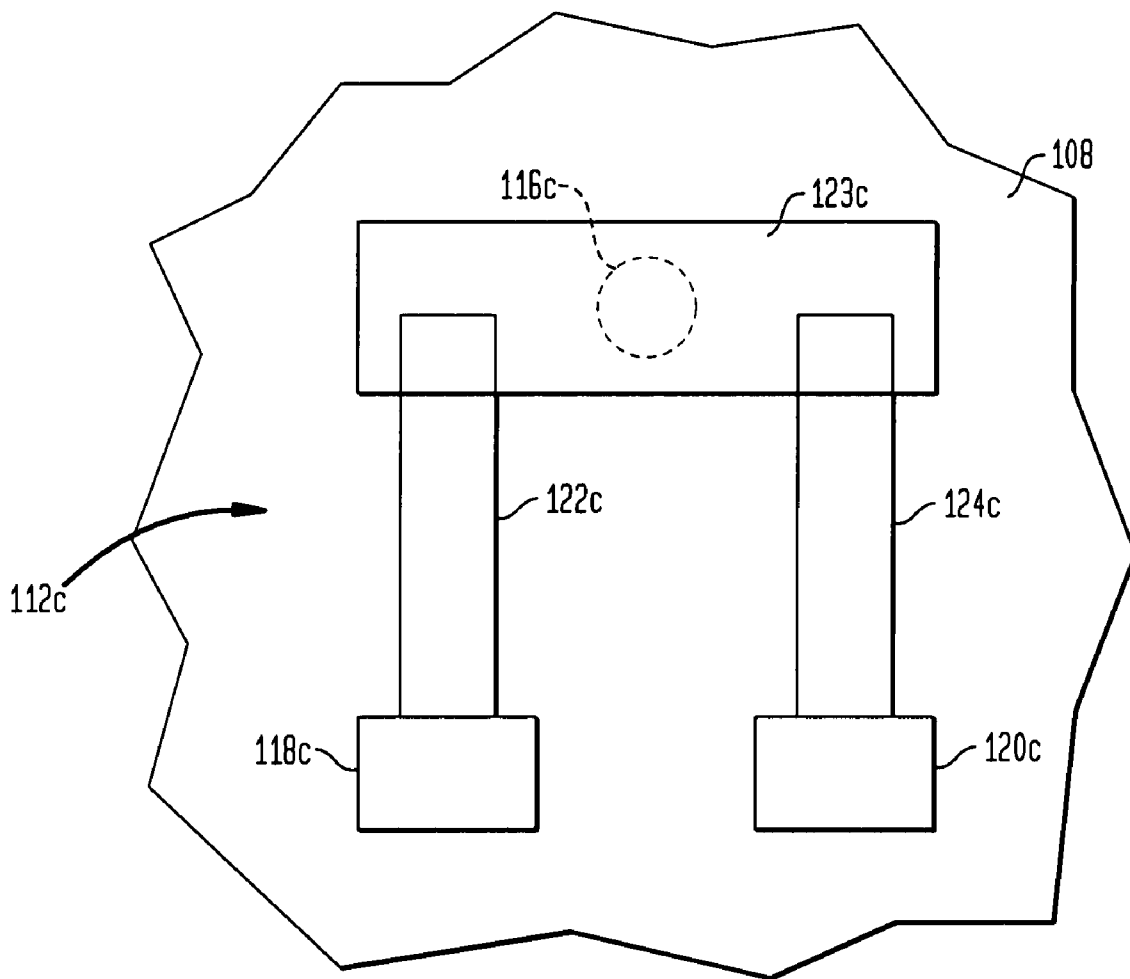



FIG. 9

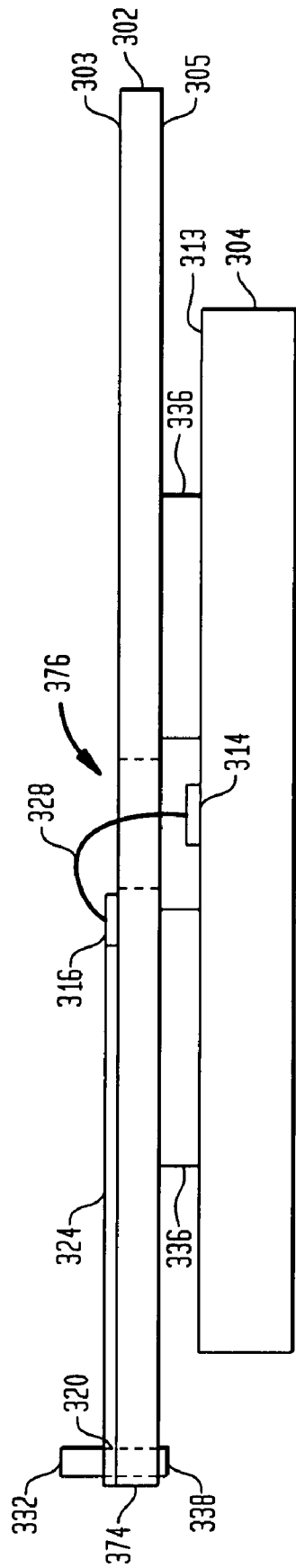

FIG. 10

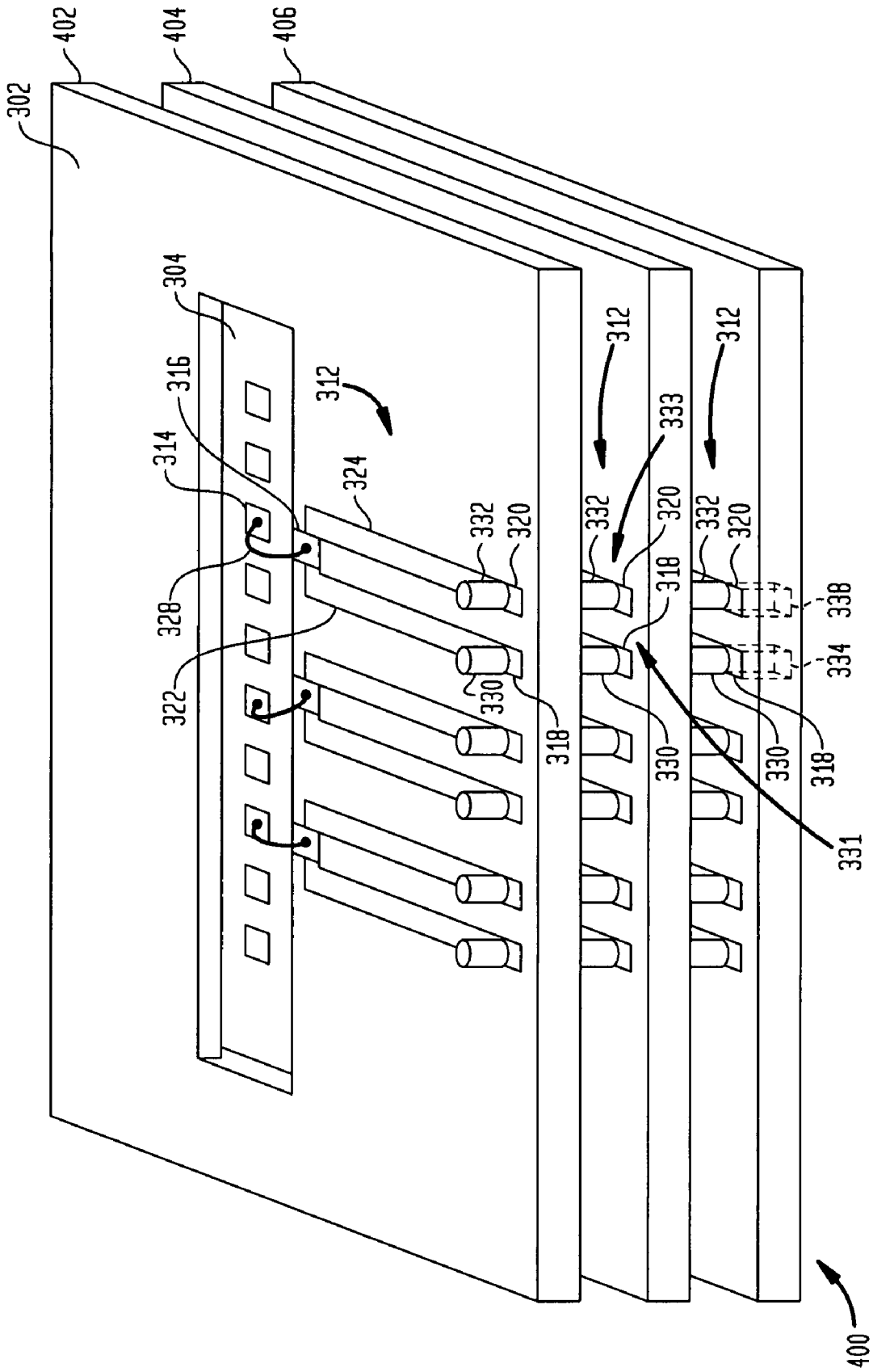

FIG. 11

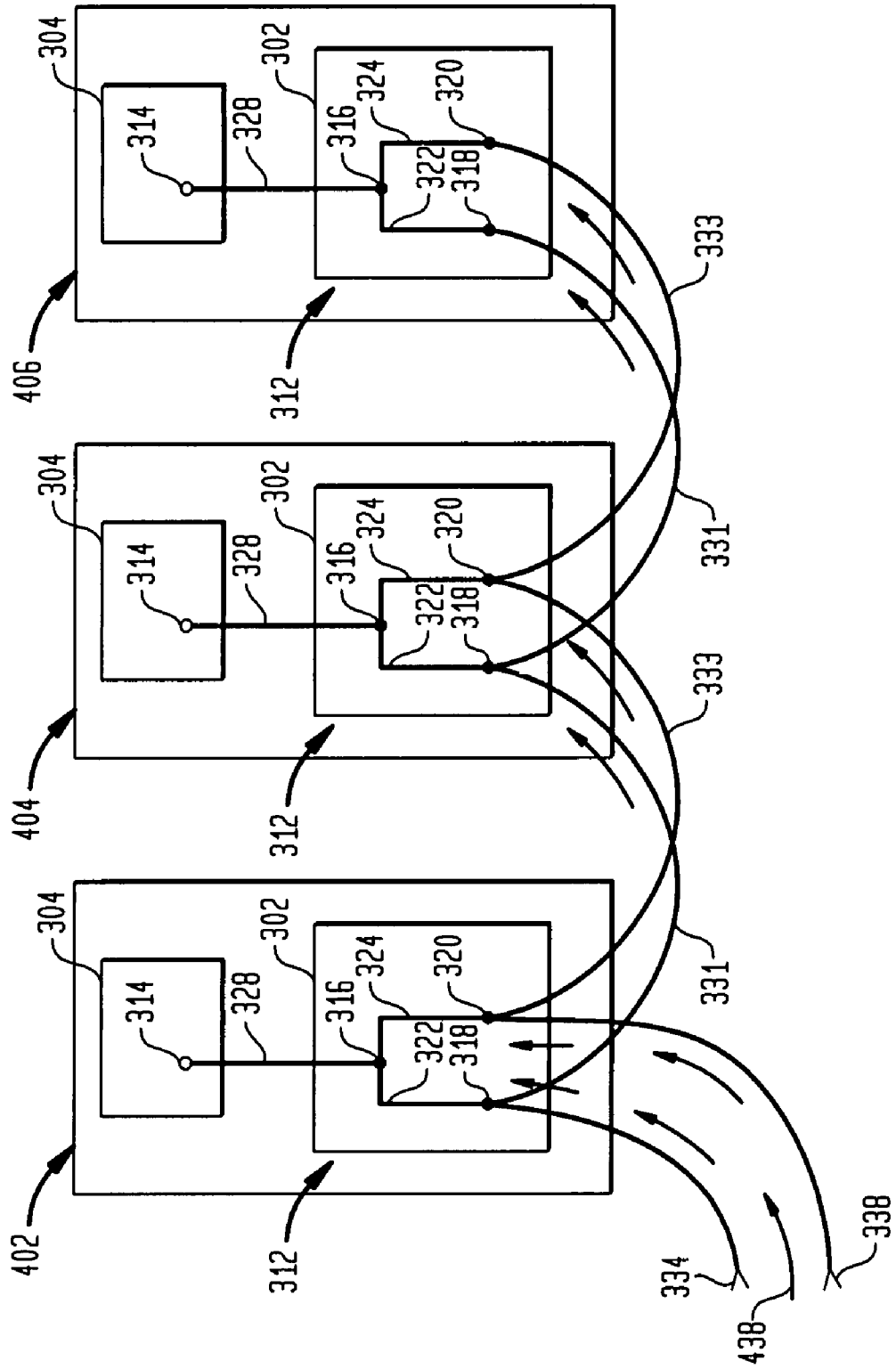
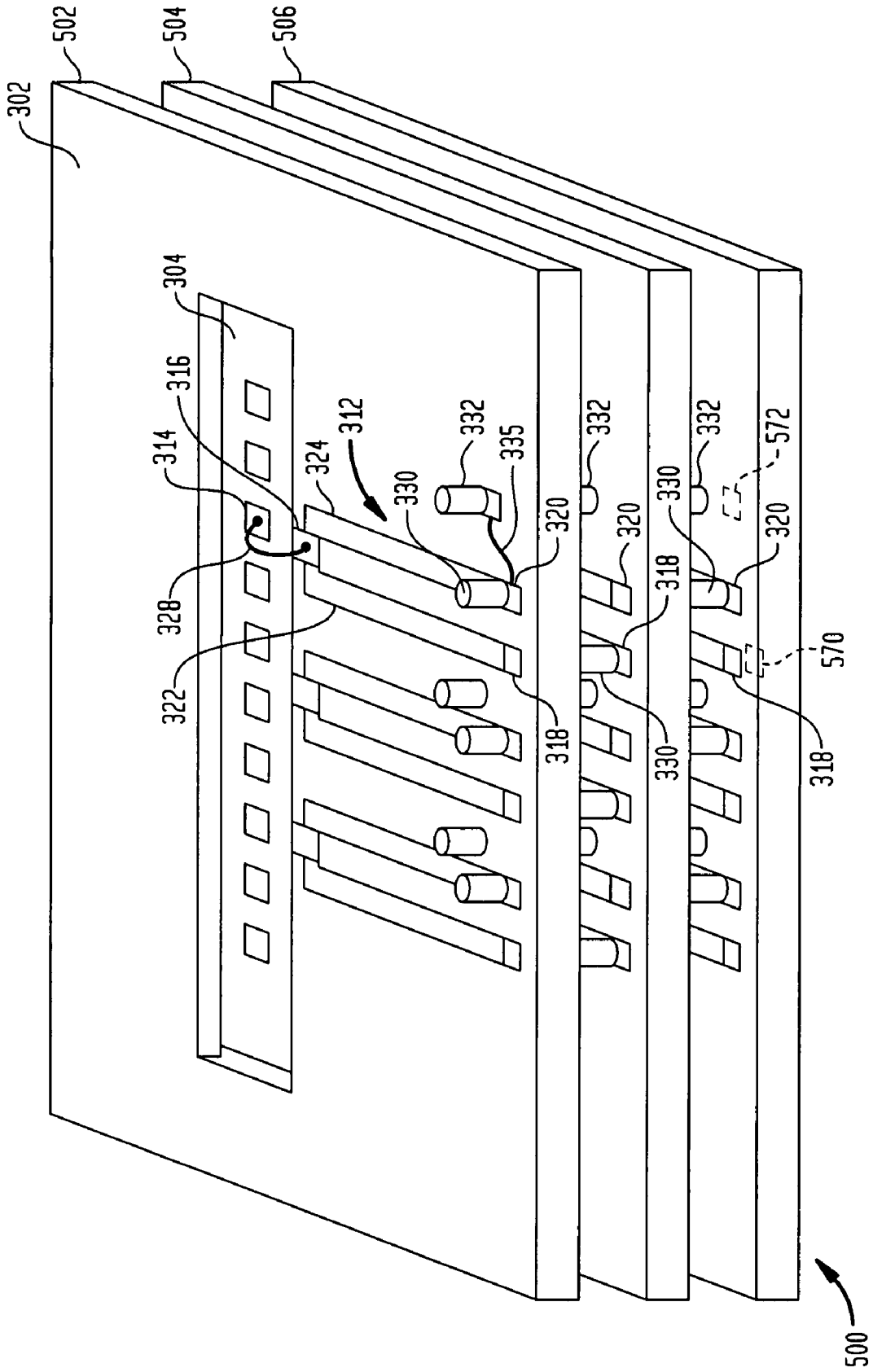

FIG. 12



# MICROELECTRONIC PACKAGE HAVING INTERCONNECTED REDISTRIBUTION PATHS

## BACKGROUND

Microelectronic devices such as semiconductor chips (microelectronic elements) typically require many input and output connections to other electronic components. The input and output connections include contacts of a semiconductor chip which are generally disposed on grid-like patterns that substantially cover a surface of the device or in elongated rows which may extend parallel to and adjacent each edge of the front surface of the device, or in the center of the front surface. Typically, the devices or chips are physically mounted on a substrate such as a printed circuit board, and the contacts of the devices must be electrically connected to electrically conductive features of the circuit board.

Semiconductor chips are commonly provided in microelectronic packages, which facilitate handling of the chip during manufacturing and during mounting of the chip on an external substrate such as a circuit board or other circuit panel. For example, many semiconductor chips are provided in packages suitable for surface mounting. A common package includes a dielectric element, commonly referred to as a "chip carrier" or "substrate" with terminals formed as plated or etched metallic structures on the dielectric. These terminals typically are connected to the contacts of the chip itself by features such as thin traces extending along the chip carrier itself and by fine leads or wires extending between the contacts of the chip and the terminals or traces.

A microelectronic package may include a single chip or may include a plurality of units, each incorporating one or more chips, stacked one on top of another along a vertical dimension. Such a stacked arrangement provides a compact package.

## SUMMARY

One aspect of the present invention provides a microelectronic unit. A unit according to this aspect of the invention desirably includes a unit structure which incorporates a microelectronic element such as, for example, a semiconductor chip, and which optionally can include other structural elements such as a unit substrate. The unit structure has a periphery. For example, where the unit structure includes only a chip, the periphery of the chip constitutes the periphery of the unit structure. Where the unit structure includes a unit substrate, the unit substrate typically defines the periphery of the unit structure. The microelectronic element has a first contact on said microelectronic element. The unit desirably also includes first and second redistribution conductive pads disposed near the periphery of structure, a first redistribution conductor connected to the first redistribution conductive pad and a second redistribution conductor connected to the second redistribution conductive pad. The first and second conductors desirably extend toward the first contact. The first and second conductors are electrically connected to one another adjacent the first contact so as to form a conductive path extending between the first and second redistribution conductive pads, and this conductive path is electrically connected to the first contact. For example, the connection between the first and second conductors may be formed by an interconnect element separate from the first contact, the interconnect element being connected by a short stub connection to the first contact. Alternatively, the connection between the first and

second conductors may be made by connecting these conductors directly to the first contact.

A further aspect of the invention provides a package which includes a plurality of units as discussed above and package terminals. The conductive paths of the various units are connected between the package terminals. For example, the structures of the units may be superposed on one another in a stacked arrangement. As discussed in greater detail below, units and packages in accordance with certain embodiments of the invention can have no stubs, or only very short stubs, and hence can minimize or eliminate the adverse effects associated with stubs.

## BRIEF DESCRIPTION OF THE DRAWINGS

FIG. 1 illustrates a perspective view of a microelectronic package configured to communicate over a serial transmission line in accordance with an embodiment of the present invention.

FIG. 2 illustrates an elevational view of the microelectronic package of FIG. 1 taken along line 2-2.

FIG. 3 illustrates a schematic diagram of the microelectronic package of FIGS. 1 and 2.

FIG. 4 illustrates a perspective view of a microelectronic package configured to communicate with a parallel transmission line in accordance with an embodiment of the present invention.

FIG. 5 illustrates an elevational view of the microelectronic package of FIG. 4 taken along line 5-5.

FIG. 6 illustrates a schematic diagram of the microelectronic package of FIGS. 4 and 5.

FIGS. 7A-7C illustrate conductive path structures according to other embodiments of the present application.

FIG. 8 illustrates a perspective view of a microelectronic unit in accordance with yet another embodiment of the present invention.

FIG. 9 illustrates an elevational view of the microelectronic unit of FIG. 8.

FIG. 10 illustrates a perspective view of a microelectronic package in accordance with another embodiment of the present invention.

FIG. 11 illustrates a schematic diagram of the microelectronic package of FIG. 10.

FIG. 12 illustrates a perspective view of a microelectronic package in accordance with yet another embodiment of the present invention.

## DETAILED DESCRIPTION

Referring to FIGS. 1 and 2, shown is a microelectronic package **100** in accordance with one embodiment of the invention. The package **100** includes a plurality of units **104**, **106**, **108**. In this embodiment, the structure of each unit includes a microelectronic element such as a semiconductor chip having a unitary body **170** with electrical circuits disposed within the body, one such circuit being schematically indicated at **172**. Unit **108**, depicted at the top in FIG. 1, has a first contact **116** exposed at a front or first surface **113** of body **170**. Contact **116** is electrically connected to the internal circuitry **172** within the interior of the chip.

Unit **108** also includes first and second redistribution pads **118** and **120** exposed at the front surface **113** of body **170**. Pads **118** and **120** are disposed remote from first contact **116**, and lie near a first edge **174** of body **170** and hence near the periphery of the structure forming unit **108**. Unit **108** also includes a first redistribution conductor **122** connected to first redistribution pad **118** and a second redistribution conductor

**124** connected to the second redistribution pad **120**. The redistribution conductors extend from redistribution pads **118** and **120** toward first contact **116**. Redistribution conductors **122** and **124** are connected to one another by an interconnect element **123** disposed adjacent to first contact **116** and remote from the redistribution pads **118** and **120**. Thus, the redistribution conductors **122** and **124**, together with the interconnect element **123**, form a first conductive path **112** connecting the first and second redistribution pads **118** and **120** with one another. Stated another way, path **112** connects a first pair of redistribution pads **114** including pads **118** and **120** to one another.

In the particular embodiment shown, path **112** is connected to contact **116** by a very short stub conductor **117** which extends between the interconnect element **123** and the first contact **116**. The redistribution conductors **122** and **124** and the interconnect element desirably have low impedance. For example, the redistribution conductors may have cross-sectional area many times greater than the very fine conductors typically used within the internal structure of the semiconductor chip itself. Also, the redistribution conductors may be formed from materials different from those used within the internal structure of the chip itself. For example, the chip body may include one or more passivation layers defining the front surface **113**, and the redistribution conductors may be formed after deposition of one or more of the passivation layers, so that the metal constituting the redistribution conductors is isolated from the internal structure of the chip. This facilitates use in the redistribution traces of metals such as copper which may be incompatible with the processes used to fabricate internal elements of the chip.

Chip or unit **108** has numerous other contacts and other pairs of redistribution pads with conductive paths similar to path **112** discussed above. Only three contacts and three conductive paths are depicted in FIG. 1 for clarity of illustration. The other units **104** and **106** are identical to unit **108**.

The package according to this embodiment further includes a package substrate **102**. Package substrate **102** includes a first contact pad **110a** and a second contact pad **110b**, a first terminal **111a** electrically connected to the first contact pad **111a** and a second terminal **111b** electrically connected to the second contact pad **110b**. Terminals **111** are adapted for connection to an external circuit element such as a circuit panel. For example, package substrate **102** can be a conventional IC package substrate such as a ball grid array (BGA) substrate, pin grid array (PGA) or the like. Terminals **111** may be formed integrally with contact pads **111** or may be formed separately from the contact pads. Merely by way of example, in a BGA substrate, a single piece of metal may have an upwardly-facing surface exposed at the top surface of the substrate defining one of the contact pads and a downwardly-facing surface exposed at the bottom surface of the substrate defining one of the terminals.

Units **104**, **106** and **108** are arranged in a stack atop substrate **102**, with the front or first surface **113** of one unit facing upwardly toward the bottom or rear surface of the next higher unit in the stack. In the particular embodiment depicted, the units are staggered with respect to one another. As best seen in FIG. 1, middle unit **106** is offset slightly from bottom unit **104** in the direction toward the rear of the drawing, so that the first edge **174** of middle unit **106** is offset from the first edge **174** of bottom unit **104**, and so that the edge region of bottom unit **104**, bearing redistribution contacts **118** and **120** is not covered by unit **106**. Likewise, top unit **108** is offset from middle unit **106**, leaving the edge region of middle unit **106** uncov-

ered. The bottom unit **102** is placed so that its first edge **174** is close to the contact pads **110** of the substrate but does not cover the contact pads.

Non-conductive spacers **126** (FIG. 2) are placed between the chips of the units in the stack, and between bottom unit **104** and package substrate **102** to provide spacing between the chips as well as between the chips and the substrate. The spacers also allow clearance for the conductors between adjacent chips. The spacers **126** can be made of dielectric material such as polyimide or other similar material and can include thermally conductive material. The chips **104**, **106**, **108**, substrate **102** and spacers **126** may be mounted to one another using an adhesive **128** such as epoxy or other mounting technique. The package substrate **102** and the units **104**, **106**, **108** form a package **100**. The elements of the package, including the units, the package substrate and the electrical interconnections discussed below, optionally may be encapsulated as by epoxy over-molding (not shown) or other encapsulants.

In this embodiment, the units **104**, **106**, **108** are electrically connected in a serial transmission line **138**. The transmission line comprises interconnect conductors **130**, **132**, **134**, **136** in the form of wire bonds, in combination with the first conductive path **112** on each of the units. The first interconnect conductor **130** is electrically connected between a contact pad **110b** of the package substrate **102** and a first redistribution conductive **118** pad of the pair of redistribution conductive pads **114** of the first or bottom unit **104**. A second interconnect conductor **132** is electrically connected between a second contact **110a** of the pair of pads on substrate **102** and a second redistribution conductive pad **120** of the third or top unit **108**. The third interconnect conductor **134** is electrically connected between a second redistribution conductive pad **120** of the first chip **104** and a first redistribution conductive pad **118** of the second or middle unit **106**. In a similar manner, the fourth conductor **136** is electrically connected between a second redistribution conductive pad **120** of the second or middle unit **106** and a first redistribution conductive pad **118** of the third or top unit **108**.

The package **100** as described above is shown in FIGS. 1 and 2 in an assembly with a circuit panel **109** such as a circuit board having a pair of conductive features such as traces **178a** and **178b**. These traces may connect to other components (not shown) of a larger circuit. In the assembly as shown, package substrate **102** is mounted on the circuit panel, with terminals **111a** and **111b** connected to conductive features **178a** and **178b**, respectively.

FIG. 3 illustrates a schematic diagram of the package **100** of FIGS. 1 and 2. Transmission line **138** is connected by terminals **111a** and **111b** between conductive features **178b** and **178a** of the circuit panel. In operation, an electrical signal applied to transmission line **138** propagates from contact pad **110b** through conductor **130** and through the first conductive path **112** of the first unit **104**, then through conductor **134** and the first conductive path **112** of second unit **106**, and finally through conductor **136** and the first signal path **112** of the third unit **108** and conductor **132** to contact pad **110a**. The propagating signal does not encounter a dead-end or stub, and hence does not create appreciable reflected signals. The signal passing through the conductive path **112** of each unit also passes along the stub **117** to the first contact **116** of the chip in such unit, and into the internal circuitry of the chip. However, because stub **117** is very short, any signals reflected at the end of the stub are nearly in phase with the signal passing along the conductive path. This mitigates or substantially eliminates the adverse effects of the reflected signals. Moreover, the short lengths of the stubs reduce radiation of signals from the stubs. The short stubs are provided even though the con-

tacts **116** of the chips incorporated in the unit are remote from the first edge **174** where the connections between the unit and circuits external to the unit are made. Certain semiconductor chips are made with contacts disposed in one or more rows remote from the edges of the chip as, for example, a single row of contacts extending in the center of the chip. Redistribution conductive pads and conductive paths as shown can be added using a few processing steps at the end of the normal wafer processing cycle used to make such chips. This allows transformation of chips originally designed with rows of contacts remote from the edges into chips with connections near the edges, without extensive redesign of the chip and processing operation, and without creating long stubs.

The interconnect conductors **130**, **132**, **134**, **136** included in the transmission line **138** can be wire bonds as depicted in FIGS. **1** and **2**, or can be formed as parts of a flexible circuit tape, or can include any other form of conductor. Three units **104**, **106**, **108** are shown for illustrative purposes but any number of units, including a single unit or more than three units, can be used. A single transmission line **138** has been shown for simplicity but a plurality of transmission lines can be used. The conductive paths **112** are shown as having a single contact connected to two redistribution conductive pads **118**, **120**. However, it is contemplated that the conductive paths can have a different number of contacts and conductive pads. For example, two or more contacts can be connected to a given conductive path, and a given conductive path can include three redistribution conductive pads. In addition, the shape of the conductive path is shown in FIG. **1** as generally U-shaped. However, other configurations are possible. For example, the conductors **122**, **124** are shown as having a straight shape but they can be curved, serpentine or another shape.

In an alternative embodiment, the package substrate **102** is itself a circuit board having conductive features for mounting and connecting other components. The chips included in units **104**, **106**, **108** and the substrate **102** are shown as generally flat, rectangular body structures with planar surfaces but it is contemplated that the structures can have other shapes such as square shape and other surfaces such as irregular, stepped or other.

Referring to FIGS. **4** and **5**, shown is a microelectronic package **200** in accordance with another embodiment of the present application. The package **200** has units **104**, **106**, **108** disposed on each other and over package substrate **102** in a similar manner as in package **100** of FIGS. **1-3**. The individual units, package substrate and physical arrangement are identical to the corresponding features of the embodiment discussed above with reference to FIGS. **1** and **2**. Thus, the chips constituting units **104**, **106**, **108** each have individual conductive paths **112** identical to conductive paths **112** discussed above. However, in the package **200** of FIGS. **4** and **5**, the conductive paths are electrically connected in parallel between the contact pads **110** of the package substrate, rather than in series as discussed above, so that the conductive paths **112** of the units and the interconnect conductors constitute a parallel transmission line **148**. In particular, interconnect conductors **152**, **154**, and **156** are electrically connected between a first contact pad **110** of package substrate **102** and the first redistribution conductive pad **118** of the first, second and third chips **104**, **106**, **108**, respectively. Interconnect conductors **162**, **164** and **166** are connected between the other contact pad **110** of the substrate and the second redistribution pads **120** of the chips **104**, **106**, **108**, respectively.

FIG. **6** illustrates a schematic diagram of the microelectronic package of FIGS. **4** and **5**. In operation, an electrical signal **150** is applied to the transmission line **148** at the two

contact pads **110** of the substrate **102**. The signal **150** propagates in a parallel manner to the conductive path **112** of the first unit **104** via a first path formed from the first conductor **152** and the redistribution conductive pad **118** and returns via the second redistribution conductive pad **120** and conductor **162**. Likewise, the same signal propagates in a parallel manner to the second unit **106** and the third unit **108**. Thus, the configuration of the conductive paths **112** along with the transmission line allows a signal to propagate in a parallel manner to the chips **104**, **106**, **108**. The features and advantages of the package **200** are similar to those of the package **100** of FIGS. **1-3** and thus are not described for simplicity.

FIGS. **7A-7C** illustrate conductive path structures according to other embodiments of the present application.

FIG. **7A** shows a conductive path **112a** similar to the structure **112** of FIG. **1**. For example, structure **112a** includes a first redistribution conductive pad **118a** with a first conductor **122a** extending towards contact **116a** and a second redistribution conductive pad **120a** with a second conductor **124a** extending towards the contact **116a**. Contact **116a**, like contact **116** of FIG. **1**, is electrically connected to the internal circuitry (not shown) within the interior of the chip. However, in the embodiment of FIG. **7A**, the first conductor **122a** is connected to the contact **116a** and the second conductor **124a** is connected to the contact **116a**. In this embodiment, the conductors **122a** and **124a** are connected to one another only by the contact **116a**, so that the signal path **112a** between the redistribution contacts extends through the pad itself. Thus, there is no stub at all.

FIG. **7B** shows a conductive path **112b** similar to the conductive path **112a** of FIG. **7**. For example, structure **112b** includes a first redistribution conductive pad **118b** with a first conductor **122b** extending towards contact **116b** and a second redistribution conductive pad **120b** with a second conductor **124b** extending towards the contact **116b**. Contact **116b**, like contact **116** of FIG. **1**, is electrically connected to the internal circuitry (not shown) within the interior of the chip. However, the first conductor **122b** includes a main section formed as a trace integral with redistribution conductive pad **118b** and an end section **127b** formed as a wire bond between the main section and the contact **116**. The second conductor **124b** is connected to the contact **116b** through a similar end second **127b**.

FIG. **7C** shows a conductive path **112c** similar to the structure **112** of FIG. **1**. For example, structure **112c** includes a first redistribution conductive pad **118c** with a first conductor **122c** extending towards contact **116c** and a second redistribution conductive pad **120c** with a second conductor **124c** extending towards the contact **116c**. Here again, an interconnect element **123c** connects the ends of the conductors adjacent contact **116c**. Contact **116c**, like contact **116** of FIG. **1**, is electrically connected to the internal circuitry (not shown) within the interior of the chip. In this embodiment, the interconnect element extends directly over contact **116c** and is electrically connected to the contact. Thus, no stub is required.

FIGS. **8** and **9** show a unit **300** in accordance with another embodiment of the present application. In this embodiment, the structure of unit **300** includes a unit substrate **302** and a chip **304**. As seen in FIG. **9**, the unit substrate is disposed over the front surface **313** of chip **304**. In this embodiment, the chip has contacts **314** exposed at its front surface. The unit substrate **302** includes a dielectric element having a front surface **303**, a first edge **374** projecting beyond an edge of the chip, and a hole **326** extending through the dielectric substrate remote from the first edge and aligned with the contacts **314** of the chip. In the particular embodiment depicted, the con-

tacts **314** of the chip are arranged in a row, and the hole **326** is in the form of an elongated slot. Non-conductive spacers **336** optionally may be disposed between the chip **304** and the unit substrate **302**.

Unit **300** also includes a plurality of conductive paths **312**. The conductive paths **312** of unit **300** are similar to the conductive paths **112** of the individual units discussed above with reference to FIGS. **1** and **2**. In this embodiment, however, the conductive paths **312** of unit **300** are disposed principally on unit substrate **302** rather than on the chip. Each conductive path **312** includes first and second redistribution conductive pads **318**, **320** exposed at the front surface **303** of the unit substrate and disposed near the periphery of the unit substrate, adjacent first edge **374** in a region of the unit substrate which projects beyond chip **304**. The first redistribution conductive pad **318** is connected to a first conductor **322** extending towards hole **326** and towards a contact **314** of the chip via a conductor **328**. Likewise, the second redistribution conductive pad **320** is connected to a second conductor **324** extending towards and electrically connecting to the contact **314** of the chip. Although conductors **322** and **324** are depicted as extending on the front surface **303** of the unit substrate, the conductive paths **312** or components thereof such as conductors **322** and **324** can be disposed within the substrate and not exposed on the front surface of the substrate.

The redistribution conductive pads **318**, **320** of package **300** include respective conductive posts **330**, **332** each having a base connected to the pads and a tip projecting upwardly from the front surface of the substrate. The conductive posts **330**, **332** can be formed integrally with the respective conductive pads. The conductive pads **318**, **320** are exposed at a bottom surface **305** of the substrate **302** to form bottom side contacts **334**, **338** to allow for electrical inter-connection between packages, as explained below in further detail.

In this embodiment as well, the first conductor **322** and second conductor **324** of each conductive path are connected to one another at the ends of the conductors remote from the redistribution conductive pads **318** and **320**, by an interconnect element **316**. The interconnect element **316** of each conductive path **312** is connected to a contact **314** of the chip by stub in the form of a wire bond **328** extending between the interconnect element and the chip contact.

FIG. **10** shows a package **400** including a plurality of units **402**, **404**, **406**, each of which has the structure discussed with reference to FIGS. **8** and **9**. In this package, the units are stacked one on top of another along a vertical dimension. Thus, the second unit **404** is sandwiched between the first package **402** and the third package **406**. The packages **402**, **404**, **406** are stacked in a manner to align the conductive posts **330**, **332** of a lower positioned unit (e.g., unit **404**) with the bottom surface contacts **334**, **338** of the next higher positioned unit (e.g., unit **402**) which allows an electrical connection between the packages. The units are aligned with one another so that the corresponding redistribution conductive pads on the various packages are aligned with one another and connected to one another, as by soldering connections between the posts and the bottom surface contacts. Thus, all of the first redistribution pads **318** are connected to one another to form a first vertical bus **331**, whereas all of the second redistribution pads **320** are connected to one another to form a second vertical bus **333**.

The posts and bottom surface contacts are only shown diagrammatically in the drawings. The actual physical configuration of the posts, bottom surface contacts and solder connections between these elements may be in accordance with United States Published Patent Application No. 2005/0285246 A1, the disclosure of which is incorporated by refer-

ence herein. Also, the posts may project from the bottom surface instead of from the top surface, or from both surfaces. Other types of stackable contacts can be used. For example, as shown in U.S. Pat. Nos. 6,897,565 and 6,977,440, the disclosures of which are incorporated by reference herein, the redistribution conductive pads can be simple flat pads exposed at the top and bottom surfaces of the unit substrate, with the aligned pads being connected to one another by conductive elements such as solder balls interposed between them.

The first conductive paths **312** are connected in parallel between busses **331** and **333**. The bottom surface contacts **334** and **338** of the bottom unit **406** (FIG. **10**) form terminals for busses **331** and **338**, respectively. In use, the package is assembled with a circuit board (not shown), and the terminals or bottom surface contacts of bottom unit **406** are connected to conductive features of the circuit board.

FIG. **11** illustrates a schematic diagram of package **400** of FIG. **10**. In operation, an electrical signal **438** is applied to the first and second busses **331** and **333**, and passes between these busses via the conductive paths **312** of the various units **402**, **404** and **406**. In this embodiment as well, the signal passing through the conductive paths also passes to the chips via the short stubs **328**. Here again, however, the stubs are so short that the adverse effects created by the stubs are minimized.

FIG. **12** shows a microelectronic package **500** in accordance with another embodiment of the present application. However, the package includes conductive elements configured to form a serial transmission line rather than the parallel transmission line of the package shown in FIGS. **10-11**. The package **500** comprises a plurality of units **502**, **504**, **506**. Each unit includes a chip **304** and unit substrate **302** substantially identical to the chip and unit substrate discussed above with reference to FIGS. **10** and **11**. Thus, each unit substrate has a first conductive path **312** connecting a first redistribution pad **318** with a second redistribution pad **320**, such conductive path including conductors **322** and **324** which are connected to one another adjacent the contact **314** of the chip and which are connected to the chip contact **314**. Here again, the redistribution pads are disposed in an edge region of the unit substrate, outside of the perimeter of the chip **314**. In this embodiment as well, the redistribution pads are exposed at the top and bottom surfaces of the unit substrate. In this embodiment, each unit substrate carries an auxiliary conductive element **332** associated with the conductive path **312** but separate from such path.

Here again, the units are stacked and arranged one on top of another along a vertical dimension, with the corresponding redistribution pads aligned with one another and with the auxiliary conductive elements **332** aligned with one another. In this embodiment, aligned redistribution pads are connected to one another by conductive elements such as metallic posts **330** formed integrally with the redistribution pads as discussed above. However, the conductive elements are provided only at alternate ones of the redistribution pads. The second redistribution pad **320** of the first or bottom unit **506** is connected to the second redistribution pad **320** of the middle unit **504**, whereas the first redistribution pad **318** of the second or middle unit is connected to the first redistribution pad **318** of the third or top unit. The first redistribution pad **318** defines a first terminal **570** for connection to a circuit panel. The connected redistribution pads and conductive paths of the various units form a series connection extending from terminal **570**, through the conductive path of the first or bottom unit **506** to the second redistribution pad **320** of that unit, then through the second redistribution pad **320** of second or middle unit **504** and through the conductive path of that unit to the first redistribution pad **318** of the middle unit, and then

through the first redistribution pad **318** of the top unit **302** and through the conductive path **312** of the top unit to the second redistribution pad **320** of the top unit. The second redistribution pad **320** of the top unit **502** is connected to the auxiliary conductive element of that unit. For example, a wire bond **335** or other connection can be formed at this location before or after the units are stacked and assembled to one another. The wire bond **335** can be attached between a pad electrically connected to the auxiliary conductive element **332** and the second redistribution pad **320**. The auxiliary conductive elements **332** are connected to one another, and the bottom unit **506** has a further terminal **572** connected to the auxiliary conductive elements **332**. Thus, the conductive paths **312** of the various elements are connected in series between terminals **570** and **572**. This package operates in substantially the same manner as the series-connected package discussed above with reference to FIGS. 1-3.

Although the invention herein has been described with reference to particular embodiments, it is to be understood that these embodiments are merely illustrative of the principles and applications of the present invention. It is therefore to be understood that numerous modifications may be made to the illustrative embodiments and that other arrangements may be devised without departing from the spirit and scope of the present invention as defined by the appended claims.

The invention claimed is:

1. A microelectronic unit comprising:

a unit structure including a semiconductor chip, said semiconductor chip including circuitry within an interior of said chip, said unit structure defining a first surface and a periphery;

a first contact on said semiconductor chip connected to the circuitry; and

first and second redistribution conductive pads disposed near the periphery of structure;

a first redistribution conductor connected to the first redistribution conductive pad;

a second redistribution conductor connected to the second redistribution conductive pad,

wherein the first and second conductors extend toward and are electrically connected to the first contact and are electrically connected to one another adjacent the first contact so as to form a conductive path extending between the first and second redistribution conductive pads, the conductive path limiting reflection of a signal propagating along the conductive path between the conductive pads and the circuitry within the interior of the chip.

2. The microelectronic unit of claim 1 wherein said redistribution conductive pads and said redistribution conductors are carried on said semiconductor chip.

3. The microelectronic unit of claim 1 wherein said semiconductor chip includes an element body having a front sur-

face, said first contact and said redistribution conductive pads being exposed at said front surface.

4. The microelectronic unit of claim wherein said unit structure includes a dielectric unit substrate and said semiconductor chip, said redistribution conductors and said redistribution conductive pads being carried on said unit substrate.

5. The microelectronic unit of claim 4 wherein said semiconductor chip includes an element body having a front surface, said unit substrate overlying said front surface.

6. The microelectronic unit of claim 1, wherein the first and second conductors comprise copper traces.

7. The microelectronic unit of claim 1 further comprising an interconnect element extending between said first and second conductors adjacent the first contact, said conductive path including said interconnect element.

8. The microelectronic unit of claim 7 further comprising a stub conductor extending between said interconnect element and said first contact so that said conductive path is connected to said first contact by said stub conductor, said stub conductor being shorter than said first and second conductors.

9. The microelectronic unit of claim 7 wherein said interconnect element extends over said first contact and is electrically connected to said first contact.

10. The microelectronic unit of claim 1 wherein said first and second conductors are both connected to said first contact.

11. The microelectronic unit of claim 10 wherein said first and second conductors are connected to one another only by said first contact.

12. A microelectronic package comprising a plurality of units as claimed in claim 1 and first and second terminals, the conductive paths of units being connected between said first and second terminals.

13. The microelectronic package of claim 12 wherein the conductive paths of the units are electrically connected in series between said first and second terminals.

14. The microelectronic package of claim 12 wherein the conductive paths of the microelectronic elements are electrically connected in parallel between said first and second terminals.

15. The microelectronic package of claim 12 wherein said units are superposed on one another in a stack.

16. The microelectronic package of claim 12 further comprising a package substrate, said first and second terminals being carried on said package substrate.

17. The microelectronic package of claim 12 wherein said first and second terminals are adapted for surface mounting to a circuit panel.

18. An assembly including the microelectronic package of claim 12 and a circuit panel having conductive features thereon, the terminals of the package being connected to the conductive features of the circuit panel.

\* \* \* \* \*

UNITED STATES PATENT AND TRADEMARK OFFICE  
**CERTIFICATE OF CORRECTION**

PATENT NO. : 7,768,117 B2  
APPLICATION NO. : 11/809214  
DATED : August 3, 2010  
INVENTOR(S) : Belgacem Haba, Richard Dewitt Crisp and Masud Beroz

Page 1 of 1

It is certified that error appears in the above-identified patent and that said Letters Patent is hereby corrected as shown below:

Column 1, at line 54, after "of" insert --the--.  
Column 3, at line 19, after "have" insert --a--.  
Column 9, at line 35, after "of" insert --the--.  
Column 10, at line 3, after "claim" insert --1--.

Signed and Sealed this  
Twenty-sixth Day of July, 2011

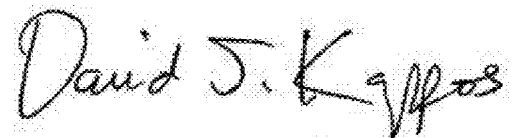
A handwritten signature in black ink that reads "David J. Kappos". The signature is written in a cursive style with a large, stylized "D" and "K".

David J. Kappos  
*Director of the United States Patent and Trademark Office*