

C. I. EARLL.  
DOUBLE CONTROLLER.  
APPLICATION FILED APR. 20, 1903.

2 SHEETS—SHEET 1.

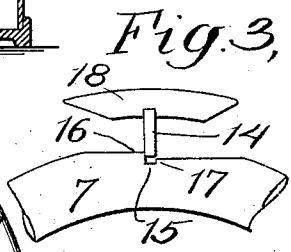
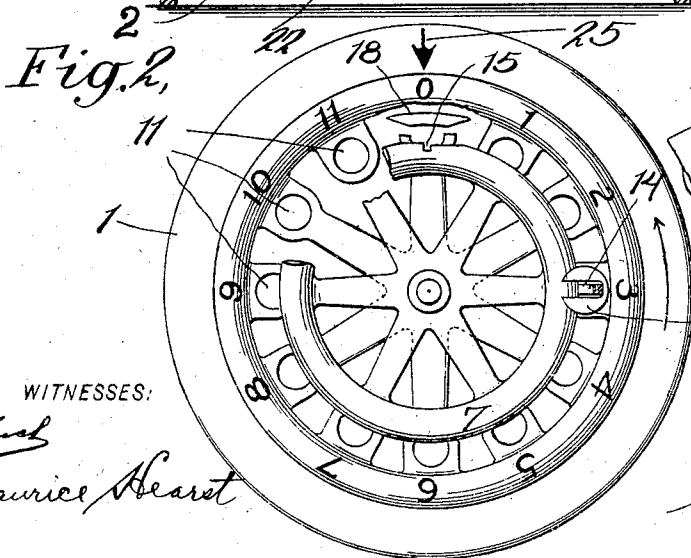
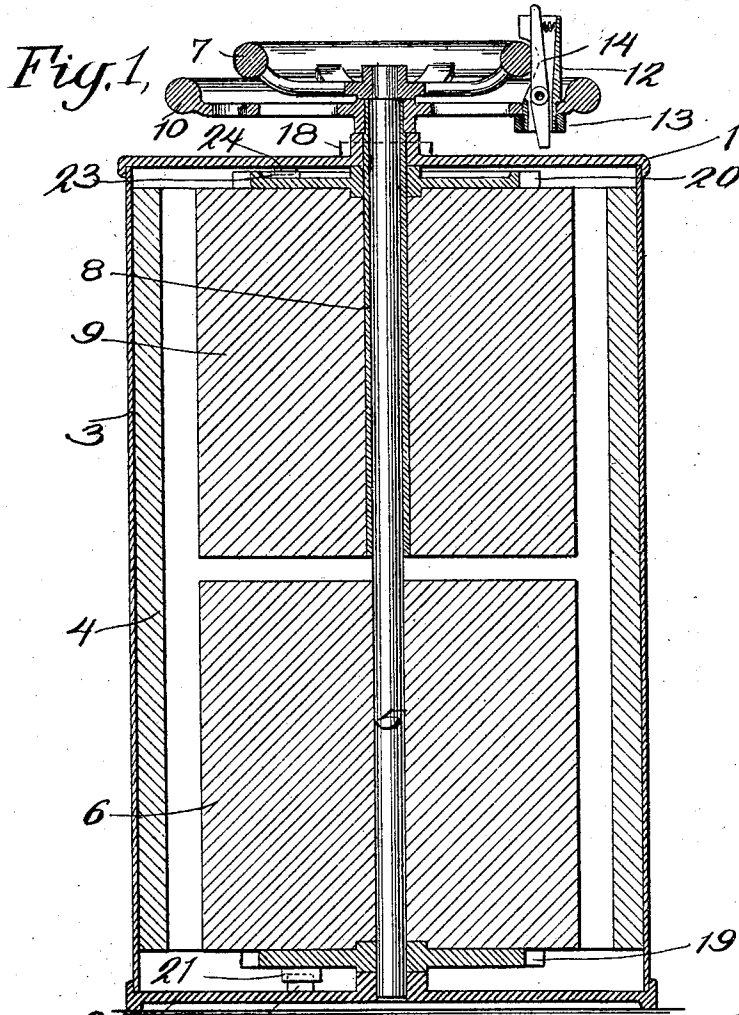

WITNESSES:

*Edw. J. ...*  
*Maurice ...*

INVENTOR

*Chas. Earll.*

C. I. EARLL.  
DOUBLE CONTROLLER.  
APPLICATION FILED APR. 20, 1903.

2 SHEETS—SHEET 2

*Fig. 4*

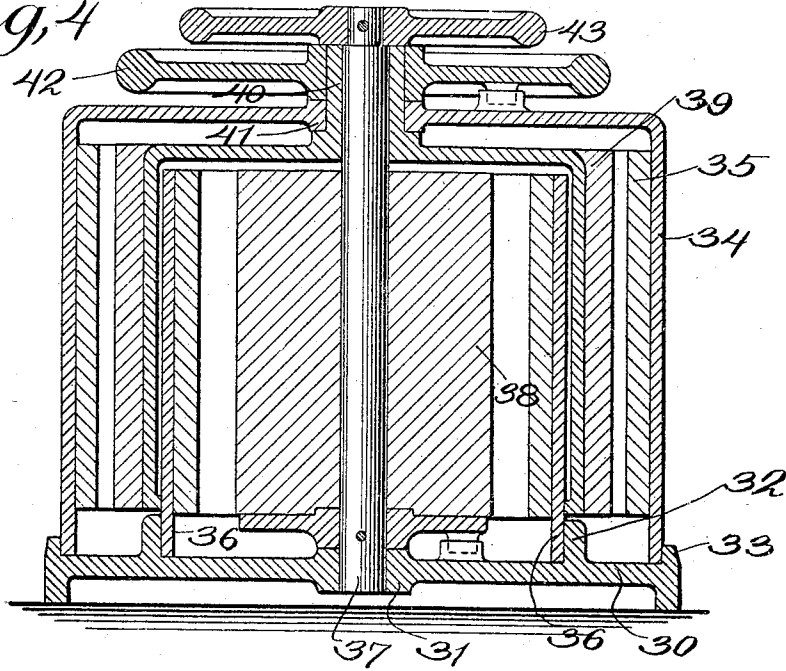

*Fig. 5,*

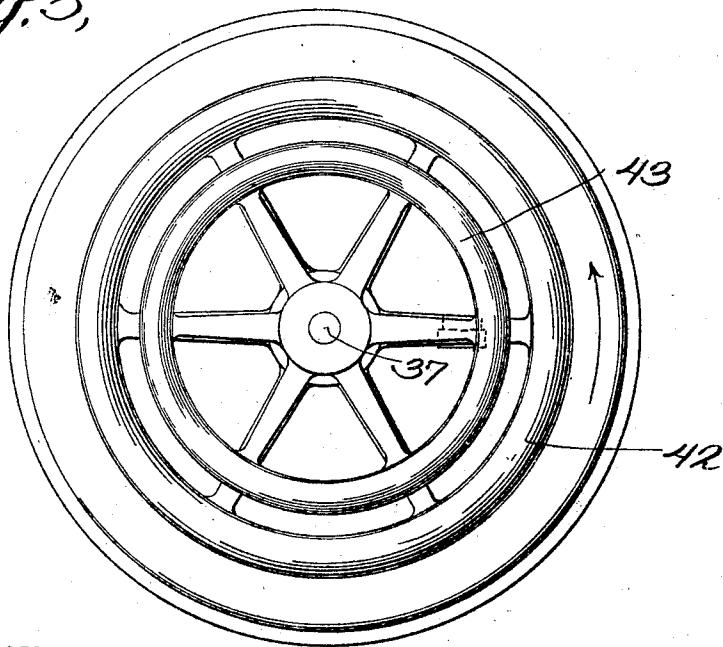

WITNESSES:

*Ellis*

*Maurice Stewart*

INVENTOR

*Chas. I. Earll*

# UNITED STATES PATENT OFFICE.

CHARLES I. EARLL, OF NEW YORK, N. Y., ASSIGNOR TO CROCKER WHEELER COMPANY, OF AMPERE, NEW JERSEY, A CORPORATION OF NEW JERSEY.

## DOUBLE CONTROLLER.

SPECIFICATION forming part of Letters Patent No. 794,792, dated July 18, 1905.

Application filed April 20, 1903. Serial No. 153,397.

*To all whom it may concern:*

Be it known that I, CHARLES I. EARLL, a citizen of the United States of America, and a resident of the city, county, and State of New York, have invented certain new and useful Improvements in Double Controllers, of which the following is a specification.

My invention relates to double or multiple controllers for controlling the operation of two or more motors where it is desirable to control the operation of the motors from a single point or location and where the operations of the motors are required under certain circumstances and conditions to operate in a certain relation with respect to each other— as, for instance, where separate motors are employed to drive the different mechanisms of certain machine-tools, such as a planer provided with one or several independently-controlled heads or slide-rests or such as a boring-mill provided with one or more boring-bars; and the object of my invention is to provide a controller of this class by means of which several controller-cylinders adapted to control, respectively, several independent motors may be conveniently operated from a single point or location and to provide means whereby the several controller-cylinders may be operated independently of each other or automatically in a certain relation to each other.

My invention consists in providing a suitable frame adapted to support insulating material for supporting contact-fingers, in mounting in said frame a plurality of concentric movable contact supporting-cylinders, in connecting said movable cylinders with concentric hand-wheels or hand-operated devices, in providing means whereby one of said hand-wheels is caused to engage another at a predetermined point to cause said hand-wheels to advance together and to return together until said predetermined point has been reached in the return movement, in providing means both automatic and non-automatic for disengaging said hand-wheels, and in other novel features of construction to be hereinafter more fully pointed out and described.

In the drawings accompanying and form-

ing part of this specification, Figure 1 represents a vertical section through the center of a controller embodying my invention. Fig. 2 represents a plan view of the controller shown in Fig. 1. Fig. 3 represents, on an enlarged scale, a portion of the mechanism controlling the engagement of one hand-wheel with another. Fig. 4 represents a longitudinal section of a modified form, and Fig. 5 represents a plan view of the form shown in Fig. 4.

The reference characters are used in the same sense in the drawings and the specification.

Numerals 1 and 2 represent, respectively, the top and bottom plates of the frame or case which carries the support for the contact-fingers.

3 represents a cover, preferably of sheet metal, lined with a cylindrical wall 4, made of insulating material.

5 represents a shaft mounted in bearings in the top and bottom plates and has secured on its lower portion the movable contact supporting-cylinder 6 and in its upper end the hand-wheel 7.

8 is a quill or hollow shaft mounted on the shaft 5, which extends upward through the central bearing in the top plate 1 to the lower end of the hub of the hand-wheel 7. Fixed upon the lower end of the quill 8 is the contact supporting-cylinder 9.

The contact supporting-cylinders 6 and 9 are made of wood or other insulating material and are adapted to have secured to their outer cylindrical surfaces contact-pieces in the usual manner. These contact-pieces are not shown, as they form no part of my present invention.

Fixed to the upper end of the quill 8 between the top plate and the hand-wheel 7 is the hand-wheel 10. The hand-wheel 10 is provided with a series of holes 11, the number of holes 11 corresponding to the number of different controller positions.

12 is a lock adapted to be received into the holes 11 and secured therein by means of the nut 13.

14 is a lever pivoted in the lock 12, the end of which is engaged by a spring which presses

it against the hand-wheel 7. The lever 14 rides upon the outer rim of the hand-wheel 7 and is adapted to engage the slot 15 formed therein. The side 16 of the slot 15 projects 5 beyond the opposite side 17.

18 is a lug or cam on the top plate 1, adapted to be engaged by the lower end of the lever 14 and to withdraw the lever 14 from the slot 15 a sufficient distance to allow the lever 10 to clear the edge 17, but not far enough to permit it to clear the edge 16 of the slot 15.

Contact-cylinders 6 and 9 are provided with detent-wheels 19 and 20, which wheels are notched around their peripheries and are 15 engaged by suitable detent-levers to retain the contact-cylinders in proper position. The detent-levers are not shown, as this construction is well understood and forms no part of my present invention. The detent-wheel 19 is provided with a lug 21, which engages the stop 22 when the cylinder 6 is returned to its normal zero position, and the detent-wheel 20 is provided with the lug 23, which engages the stop 24 when the cylinder 25 9 is returned to its normal position.

On the top of the hand-wheel 10 I place index-numerals opposite the holes 11 to correspond with the different controller positions, as indicated in Fig. 2, and on the top 30 plate 1 I place an arrow-head 25 in such a way that the index-numeral on the hand-wheel 10 which is opposite the arrow-head 25 will indicate the position at which the hand-wheel and the controller-cylinder 9, 35 which moves with it, occupy. At the same time the index-numerals on the hand-wheel opposite the lock into which the lock 12 is placed will indicate the amount which the hand-wheel 10 will turn before the hand-wheel 7 will be engaged by the lock and turn 40 with the hand-wheel 10.

As shown in Figs. 1 and 2, both the hand-wheels 7 and 10 are in their normal zero positions—that is, the positions in which no 45 current is turned on to either of the motors. It is usual to arrange the controllers so that turning the hand-wheels to the left starts the motors. If now it is desired to operate two motors so that the motor controlled by the cylinder 9 shall operate at a speed three steps 50 faster than that controlled by the cylinder 6, the lock 12 will be placed in the hole "3," as indicated in Fig. 2. Then when the hand-wheel 10 is turned to the left the hand-wheel 55 7 will remain at rest until the lock has reached a position opposite the arrow-head 25, when the lever 14 will engage the projecting side 16 of the slot 15, and the two hand-wheels will from this point turn to the left together. As 60 the lower end of the lever 14 leaves the cam 18 the lever 14 will enter the slot 15, so that when the hand-wheel 10 is returned it will carry the hand-wheel 7 with it until the hand-wheel 7 has reached this normal zero position, 65 when the lever 14 will be disengaged

from the side 17 of the notch 15 and permit the hand-wheel 10 to return from that point onto its zero position. If for any reason after two motors have been set in operation, as indicated above, it is desired to move either of 70 the hand-wheels in either direction without moving the other, it is simply necessary to withdraw the lever 14, which projects up above the lock a sufficient distance for this purpose. 75

In the modified form shown in Figs. 4 and 5, numeral 30 represents the bottom plate, provided with a central bearing 31 and annular flanges 32 and 33. 34 represents a cylindrical shell lined with insulating material 80 35. 36 represents another stationary cylindrical shell lined with insulating material fitting within the flange 32 of the bottom plate. 37 represents a centrally-located shaft on which is mounted the contact-cylinder 85 38. 39 represents a movable contact supporting-cylinder located between the stationary contact supporting-cylinders 36 and 34 and provided with a sleeve 40, which extends up through the bearing 41 and has secured upon its outer end the hand-wheel 42. 90 43 is a hand-wheel secured to the shaft 37. The purpose of this construction is to provide a sufficient surface on the contact-cylinders, both stationary and movable, for an adequate number of contact-pieces in a compact space. The hand-wheels shown in connection with this form are not provided with the interlocking devices which have been described in reference to the form shown in 100 Figs. 1 and 2. It is obvious, however, that these may be applied to this form with the same advantages and with the same facility as to the form of cylinders shown in Figs. 1 and 2. 105

Having thus described my invention, what I claim is—

1. In a controller, the combination with a plurality of controller-cylinders, automatic engaging connections between said controller-cylinders and means for adjusting said connections whereby the movement of one cylinder controls the relative movement of another in a predetermined manner. 110

2. In a controller, the combination with a plurality of movable contact supporting members, of a plurality of hand-operated devices connected respectively with said movable contact supporting members, a lock upon one of said hand-operated devices adapted to engage another of said hand-operated devices, and means for adjusting the position of said lock. 120

3. In a controller, the combination with a plurality of movable contact supporting members, of hand-operated devices connected respectively with said contact supporting members, a lock upon one of said hand-operated devices adapted to have its position thereon adjustable, means on another of said 130

hand-operated devices adapted to be engaged by said lock whereby said hand-operated devices are caused to move together and means for causing the disengagement of said lock at a predetermined point.

4. In a double controller, the combination with two controller-cylinders, of hand-wheels connected respectively to each of said cylinders, a lock upon one of said hand-wheels adapted to engage the other at a predetermined point when moved in one direction and means for causing the disengagement of said lock when said predetermined point has been reached by movement in the opposite direction.

5. In a controller, the combination with a frame and plurality of controller-cylinders mounted therein, of a plurality of concentric hand-wheels connected respectively with each of said cylinders, a lock upon one of said hand-wheels, a slot upon another of said hand-wheels adapted to be engaged by said lock, and a cam upon said frame adapted to disengage said lock.

6. In a double controller, the combination with a frame, of a shaft mounted in said frame, a cylindrical contact supporting member mounted on said shaft, a hollow shaft mounted on said shaft, a cylindrical contact supporting member mounted on said hollow shaft and concentric hand-wheels mounted on said shaft and said hollow shaft respectively for independently operating said contact supporting members.

7. In a double controller, the combination with movable contact supporting members, of means for locking said contact supporting members to cause them to move simultaneously, and means for automatically disengaging said locking means at a predetermined point.

In testimony whereof I have signed my name to this specification in the presence of two subscribing witnesses.

CHARLES I. EARLL.

Witnesses:

HARRY S. BANDLER,  
ELLA TUCH.