

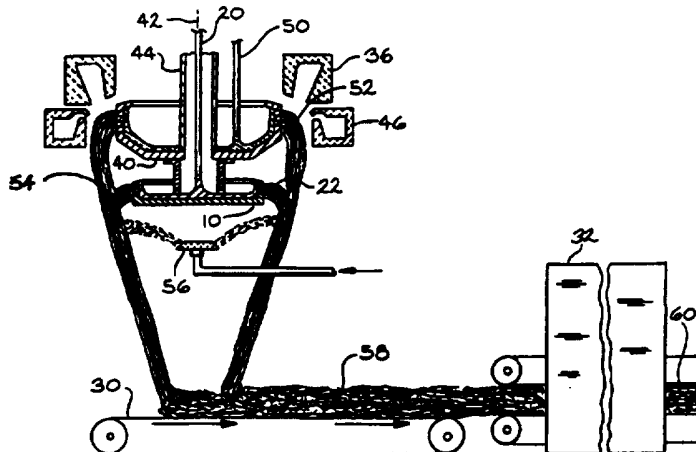

## INTERNATIONAL APPLICATION PUBLISHED UNDER THE PATENT COOPERATION TREATY (PCT)

<p>(51) International Patent Classification <sup>6</sup> : B29C 70/50, B29B 15/10, D01D 5/18, C03C 25/02</p>	A1	<p>(11) International Publication Number: <b>WO 96/19337</b></p> <p>(43) International Publication Date: 27 June 1996 (27.06.96)</p>
<p>(21) International Application Number: PCT/US95/14232</p> <p>(22) International Filing Date: 31 October 1995 (31.10.95)</p> <p>(30) Priority Data: 08/362,361 22 December 1994 (22.12.94) US</p> <p>(71) Applicant: OWENS CORNING [US/US]; Fiberglas Tower, Toledo, OH 43659 (US).</p> <p>(72) Inventors: GALLAGHER, Kevin, P.; 281 Chateaugay Drive, Pataskala, OH 43026 (US). AULT, Patrick, L.; 2795 Ritchey Road S.E., Heath, OH 43056 (US). LOFTUS, James, E.; 1239 Normandy Drive, Newark, OH 43055 (US). PELLEGRIN, Michael, T.; 505 Marion Manor Woods, Newark, OH 43055 (US). VERMILION, Donn, R.; 791 Cedar Run Road, Newark, OH 43055 (US). PONN, Frederick, H.; 4234 Lancaster Road S.W., Granville, OH 43023 (US).</p> <p>(74) Agents: GEGENHEIMER, C., Michael et al.; Owens-Corning, Science &amp; Technology Center, Building 54-1, 2790 Columbus Road, Granville, OH 43023-1200 (US).</p>		<p>(81) Designated States: AU, CA, JP, KR, MX, European patent (AT, BE, CH, DE, DK, ES, FR, GB, GR, IE, IT, LU, MC, NL, PT, SE).</p> <p><b>Published</b> <i>With international search report.</i></p>

## (54) Title: INTEGRATION OF ASPHALT AND REINFORCEMENT FIBERS



## (57) Abstract

A method for producing asphalt fibers (26) includes supplying molten asphalt (20) to a rotating asphalt spinner (10), centrifuging asphalt fibers (22) from the asphalt spinner (10), and collecting the asphalt fibers (26). The molten asphalt (20) is supplied to the asphalt spinner (10) at a temperature within the range of from about 270 °F (132 °C) to about 500 °F (260 °C). Also disclosed is a method for integrating asphalt (20) with reinforcement fibers including the steps of establishing a downwardly moving veil of reinforcement fibers, such as glass fibers (52), and centrifuging asphalt fibers (22) from a rotating asphalt spinner (10) positioned within the veil of reinforcement fibers to integrate the asphalt (20) with the reinforcement fibers. A method for making an asphalt roofing shingle (84) includes the steps of assembling together a mat of asphalt fibers (34) with a mat of reinforcement fibers, coating the assembled mats (70) to form an asphalt-coated sheet, applying granules (80) to the asphalt-coated sheet, and cutting (86) the asphalt-coated sheet into roofing shingles (84). The invention also includes the asphalt roofing shingle (84) made by this process. Further, the invention includes asphalt highway reinforcement products (116) containing asphalt fibers (26), and the method of making such products.

**FOR THE PURPOSES OF INFORMATION ONLY**

Codes used to identify States party to the PCT on the front pages of pamphlets publishing international applications under the PCT.

AT	Austria	GB	United Kingdom	MR	Mauritania
AU	Australia	GE	Georgia	MW	Malawi
BB	Barbados	GN	Guinea	NE	Niger
BE	Belgium	GR	Greece	NL	Netherlands
BF	Burkina Faso	HU	Hungary	NO	Norway
BG	Bulgaria	IE	Ireland	NZ	New Zealand
BJ	Benin	IT	Italy	PL	Poland
BR	Brazil	JP	Japan	PT	Portugal
BY	Belarus	KE	Kenya	RO	Romania
CA	Canada	KG	Kyrgystan	RU	Russian Federation
CF	Central African Republic	KP	Democratic People's Republic of Korea	SD	Sudan
CG	Congo	KR	Republic of Korea	SE	Sweden
CH	Switzerland	KZ	Kazakhstan	SI	Slovenia
CI	Côte d'Ivoire	LI	Liechtenstein	SK	Slovakia
CM	Cameroon	LK	Sri Lanka	SN	Senegal
CN	China	LU	Luxembourg	TD	Chad
CS	Czechoslovakia	LV	Latvia	TG	Togo
CZ	Czech Republic	MC	Monaco	TJ	Tajikistan
DE	Germany	MD	Republic of Moldova	TT	Trinidad and Tobago
DK	Denmark	MG	Madagascar	UA	Ukraine
ES	Spain	ML	Mali	US	United States of America
FI	Finland	MN	Mongolia	UZ	Uzbekistan
FR	France			VN	Viet Nam
GA	Gabon				

**INTEGRATION OF ASPHALT AND REINFORCEMENT FIBERS****TECHNICAL FIELD**

This invention pertains to the manufacture of asphaltic products. More particularly, this invention relates to asphalt products in a fibrous form, and methods for producing fibrous forms of asphalt.

**BACKGROUND ART**

Asphaltic products have been produced in various forms, with the primary uses of asphalt being in paving and in roofing products. The common source of asphalt is the residue or bottoms from the petroleum refining industry. This asphalt must be further refined or processed by air blowing (oxidizing) in order to raise the softening point and increase the stiffness to make useful products for roofing and specialty asphalt products. Some asphalt products have improved properties because of the addition of natural or synthetic rubbers or other organic additives.

While asphalt itself has many beneficial properties, it lacks inherent tensile strength and integrity. Therefore, many asphalt products are reinforced with such materials as glass fibers or organic fibers such as polymer fibers, and have fillers such as ground limestone. For example, asphalt roofing shingles are based on an interior web or carrier of a wet process glass fiber mat, and the asphalt itself contains about 65 percent by weight ground limestone filler. Other fillers used in asphalt products include carbon black, finely ground tires, clay, ground glass, and beads of various inorganic or organic materials.

One of the problems with reinforcing asphalt is that it is often difficult to integrate the reinforcement material into the asphalt matrix, particularly in a uniform manner. Typically, integrating the asphalt and the reinforcement is accomplished by fixing the reinforcement material into a mat or web, and applying the asphalt in molten form, as is the case in manufacturing asphalt roofing shingles. Shingle manufacturing consists of running a continuous wet process glass fiber mat into a bath of molten asphalt to cause a coating on both sides of the mat as well as filling the interstices between the individual glass fibers. This process is limited in that it can only apply a relatively uniform coating, similar to a film. It would be advantageous to be able to apply layers of asphalt into various products where the layers are not films, but are rather porous mats or other types of non-uniform layers. Also, the coating process requires assembly of the ultimate product

at a manufacturing facility with a liquid asphalt coater. It would be advantageous to be able to assemble products containing asphalt layers at field locations, such as at a road repair site.

Another known method for integrating asphalt with reinforcements is to mix  
5 the asphalt with loose or particulate reinforcement materials. Such mixing requires significant energy and capital equipment, and is not always successful in providing a uniform mix of asphalt and reinforcement. It would be advantageous to be able to uniformly intermix or integrate asphalt with reinforcement materials which are in an unfixed or loose form, rather than bound into a fixed product such as a mat. Also, it would be  
10 advantageous to be able to introduce the asphalt itself into various products in forms other than as a liquid.

Numerous reinforcement layers have been used for reinforcing highway systems. Such well known reinforcement layers include glass fibers in mat form, either woven or nonwoven, asphalt impregnated mats, mats of organic materials, such as  
15 polyester fibers, mats in the form of an open weave or grid, and layers of glass fibers or other reinforcement fibers. These reinforcement layers are applied to the roadway beneath subsequently applied bituminous aggregate asphalt layers to reinforce the bituminous aggregate. Such reinforcement layers are typically used in locations where the underlying pavement has cracked and the highway system is being repaired. Reinforcement layers can  
20 also be used on the entire highway for repaving or as original construction. Also, reinforcement layers can be used for special applications such as bridge decks. It is well known to use a tack coat on any of these highway reinforcement products to secure the reinforcement product to the roadway prior to applying the paving layer.

One of the problems with currently available highway reinforcement products  
25 is that assembling various layers making up the highway reinforcement is a time consuming and costly process. Also, it is difficult to accurately meter out the asphalt layers in such products. Further, it is not easy to fully integrate reinforcement layers of the highway reinforcement product with the asphalt without completely impregnating the reinforcement layer in a molten asphalt bath. Finally, it would be advantageous to be able to produce  
30 highway reinforcement products with higher strength without having to increase the materials used.

### DISCLOSURE OF INVENTION

There has now been developed asphalt in fibrous form and a method of producing asphalt fibers. The asphalt fibers are a new form of asphalt, and they can be used in traditional asphalt applications such as paving, roofing and specialty products, as well as new products. The asphalt fibers can be formed in a rotary process by centrifuging and can be collected as fibrous asphalt webs. The webs can be incorporated into numerous products as a layer of asphalt material.

According to this invention, there is provided a method for producing asphalt fibers comprising supplying molten asphalt to a rotating asphalt spinner; centrifuging asphalt fibers from the spinner; and collecting the asphalt fibers. The asphalt can be modified with one or more organic modifiers from the group consisting of natural rubber, synthetic rubber, elastomers, polymers, resins and other thermoplastic or thermoset materials. Preferably, the modifiers are present in an amount within the range of from about 2 to about 30 percent (weight percent of the total organic composition). Most preferably, the modifiers are present in an amount within the range of from about 4 to about 12 percent.

In a specific embodiment of the invention, the molten asphalt is supplied to the asphalt spinner at a temperature within the range of from about 270°F (132°C) to about 500°F (260°C), as measured at a delivery point just above the spinner.

In another embodiment of the invention, the asphalt is subjected to an oxidizing process sufficient to give the asphalt a softening point within the range of from about 180°F (82°C) to about 350°F (177°C), and preferably within the range of from about 200°F (93°C) to about 270°F (132°C), prior to the fiberizing process. All softening points are measured using the ring and ball method.

In yet another embodiment of the invention, the centrifuging step provides acceleration to the molten asphalt sufficient to produce primary asphalt fibers having a diameter within the range of from about 25 (635  $10^3\mu\text{m}$ ) to about 60 hundred thousandths of an inch (Ht) (1524  $10^3\mu\text{m}$ ).

In a specific embodiment of the invention, the spinner has a peripheral wall with between 500 and 25,000 orifices through which the asphalt is centrifuged. Preferably, the asphalt spinner has between 500 and 10,000 orifices.

In yet another embodiment of the invention, asphalt is centrifuged by the asphalt spinner to form primary asphalt fibers, and the primary asphalt fibers are further attenuated by an annular, downwardly moving gaseous flow from a blower to form a downwardly moving veil of asphalt fibers.

5 According to this invention, there is also provided asphalt fibers having diameters smaller than 250 Ht ( $6350 \cdot 10^3 \mu\text{m}$ ). Preferably the diameter of the asphalt fibers is within the range of from about 25 ( $635 \cdot 10^3 \mu\text{m}$ ) to about 150 Ht ( $3810 \cdot 10^3 \mu\text{m}$ ), with the asphalt having a softening point within the range of from about 180°F (82°C) to about 350°F (177°C), and preferably within a range of from about 200°F (93°C) to about 270°F  
10 (132°C), in an unfilled state. Most preferably, the diameter of the asphalt fibers is within the range of from about 25 ( $635 \cdot 10^3 \mu\text{m}$ ) to about 60 Ht ( $1524 \cdot 10^3 \mu\text{m}$ ). The asphalt fibers can be filled with a filler, and can be reinforced with reinforcement fibers, such as glass fibers.

According to this invention, there is also provided a mat of asphalt fibers, the  
15 fibers having diameters within the range of from about 25 ( $635 \cdot 10^3 \mu\text{m}$ ) to about 60 Ht ( $1524 \cdot 10^3 \mu\text{m}$ ), and the asphalt having a softening point within the range of from about 180°F (82°C) to about 350°F (177°C). The mat can be laminated as a layer to a mat of reinforcement material, such as a wet process glass fiber mat, to make a layered asphalt product.

20 Also contemplated within this invention is a method for making an asphalt roofing shingle including the steps of assembling together a layer of asphalt fibers with a mat of reinforcement fibers, coating the assembled mats with asphalt to form an asphalt coated sheet, applying granules to the asphalt coated sheet, and cutting the asphalt coated sheet into roofing shingles. The invention also includes the asphalt roofing shingle made by  
25 this process.

According to this invention, there is also provided a method for integrating asphalt with reinforcement fibers including the steps of establishing a downwardly moving veil of reinforcement fibers of heat-softenable material, such as glass fibers, supplying molten asphalt to a rotating asphalt spinner positioned within the veil of reinforcement  
30 fibers, centrifuging asphalt fibers from the asphalt spinner in a manner which directs the asphalt fibers into engagement with the veil to integrate the asphalt with the reinforcement fibers, and collecting the integrated asphalt and reinforcement fibers.

Another aspect of this invention is the use of the asphalt fibers of the invention as the input product for a carbonizing process. Carbon fibers are prepared by the controlled pyrolysis of an organic precursor in fibrous form. Commercial products have been based on rayon, polyacrylonitrile and pitch (derived from coal tar, petroleum and other sources). The process involves a number of common steps for all materials. First, fibers are produced by extrusion or melt blowing. Then the fibers are stabilized by oxidation at temperatures within the range of 200°C to 450°C, usually in air. The oxidation process gives the fiber enough structure at the molecular level to maintain its shape during the carbonization process. Finally, the fiber is carbonized at temperatures exceeding 800°C in an inert atmosphere such as argon. To improve properties the fibers are stretched during the carbonizing step to orient the molecules. Heating to higher temperatures (2500 to 3000°C) also increases the modulus and strength. The resultant carbon fibers have a wide variety of uses.

Pitch fibers are made from petroleum or coal tar pitch, and are highly aromatic, containing a large proportion of asphaltenes (about 80 to 90 percent, as measured by heptane precipitation by ASTM 3279-78). The melting point of pitch is preferred to be near 260°C, with a glass transition temperature of about 85°C. Many pitches are not compatible with polymers.

In contrast to the pitch fibers, the asphalt used to make the asphalt fibers of the current invention contains 0 to 35 percent asphaltenes, and typically 15 to 25 percent. The asphaltene content is kept low to insure compatibility with polymers added. The glass transition temperature of the asphalt is within the range of from about -15°C to about -5°C. The melting point of the asphalt is typically within the range of from about 93°C to about 116°C.

An additional aspect of the invention is a method for making highway reinforcement products including establishing a downwardly moving veil of reinforcement fibers of heat-softenable material, supplying molten asphalt to a rotating asphalt spinner positioned within the veil of reinforcement fibers, centrifuging asphalt fibers from the asphalt spinner, thereby directing the asphalt fibers into engagement with the veil to integrate the asphalt with the reinforcement fibers, feeding a reinforcement mat beneath the asphalt spinner, and collecting the integrated asphalt and reinforcement fibers on top of the

reinforcement fibers to form a highway reinforcement product. The invention also includes the highway reinforcement product produced by this method.

By supplying the asphalt layer in the form of asphalt fibers, the process of making highway reinforcement products is less time consuming and costly. The asphalt  
5 layers in such products can be more accurately metered out, and the asphalt and the reinforcement fibers can be easily integrated. Further, the use of asphalt fibers in highway reinforcement products enables products of higher strength without having to increase the materials used. Also, since it is not necessary to dip the reinforcement mat into a bath of molten asphalt, the highway reinforcement can be made without the expense and hazards of  
10 an open asphalt bath.

#### BRIEF DESCRIPTION OF DRAWINGS

Figure 1 is a schematic sectional view in elevation of apparatus for centrifuging asphalt fibers according to the method of the invention.

Figure 2 is a schematic sectional view in elevation of apparatus for  
15 cofiberizing asphalt fibers and glass fibers according to the method of the invention.

Figure 3 is a schematic view in elevation of apparatus for alternately commingling veils of asphalt fibers with veils of glass fibers.

Figure 4 is a perspective view of an asphalt fiber mat of the invention.

Figure 5 is a schematic cross-sectional view in elevation of a laminated mat  
20 containing an asphalt fiber mat and a reinforcing mat.

Figure 6 is a schematic view in elevation of a process of making asphalt roofing shingles according to the invention.

Figure 7 is a schematic plan view of an asphalt roofing shingle of the  
invention.

Figure 8 is a schematic view in elevation of a process for making a highway  
25 reinforcement product according to the invention.

Figure 9 is a schematic cross-sectional view in elevation of a highway reinforcement product according to the invention.

#### BEST MODE FOR CARRYING OUT THE INVENTION

30 As used in this specification, all references to percentage are as a percent by weight. The term "asphalt", as used in this specification includes materials sometimes referred to as "bitumen", and the two terms are viewed as synonymous with each other.



The asphalts which can be employed in this invention can be either a naturally occurring asphalt or a manufactured asphalt produced by refining petroleum, and may include straight-run fractional-derived asphalts, cracked asphalts, asphalts derived from processing such as asphalt oxidizing, propane deasphalting, steam distilling, chemically modifying, and  
5 the like. In one of its preferred embodiments, the invention is applicable to asphalts for roofing shingle production. The asphalt can be either modified or unmodified.

As shown in Figure 1, the apparatus for producing asphalt fibers from a rotary process includes rotatably mounted asphalt spinner 10 which is comprised generally of spinner bottom wall 12 and spinner peripheral wall 14. The asphalt spinner can be cast  
10 from nickle/cobalt/chromium alloy as used for the production of glass fibers, or can be any other suitable spinner such as one from welded stainless steel. The spinner peripheral wall has numerous orifices 16 for the centrifugation of asphalt fibers, and preferably has between about 500 and about 25,000 orifices.

Molten asphalt is dropped into the rotating asphalt spinner as stream 20.  
15 Upon reaching the spinner bottom wall, the molten asphalt is driven radially outwardly and up the peripheral wall where centrifugal force centrifuges the asphalt through the orifices as asphalt streams or primary asphalt fibers 22. After emanating from the asphalt spinner, the primary asphalt fibers 22 are directed downwardly by annular blower 24 to form a downwardly moving flow or veil 25 of asphalt fibers. Any means can be used for turning  
20 the fibers from a generally radially outward path to a path directed toward a collection surface.

In one embodiment of the invention, centrifugal attenuation by the rotation of the asphalt spinner is sufficient to produce asphalt fibers of the desired fiber diameter, and no further attenuation is needed. The centrifuging process provides acceleration to the  
25 molten asphalt sufficient to produce primary asphalt fibers having a diameter below about 250 Ht ( $6350 \cdot 10^3 \mu\text{m}$ ), preferably within the range of from about 25 ( $635 \cdot 10^3 \mu\text{m}$ ) to about 150 Ht ( $3810 \cdot 10^3 \mu\text{m}$ ), and most preferably within the range of from about 25 ( $635 \cdot 10^3 \mu\text{m}$ ) to about 60 Ht ( $1524 \cdot 10^3 \mu\text{m}$ ). In another embodiment of the invention, secondary attenuation is used to further attenuate the primary fibers. In that case the blower is  
30 supplied with sufficient air pressure to pull the primary fibers and further attenuate them into the desired final asphalt fiber diameter. As shown in Figure 1, the blower attenuates

the primary fibers into final fibers 26, which are collected as asphalt fiber web 28 on any suitable collection surface, such as conveyor 30.

Subsequent to the asphalt fiber forming step, the asphalt fiber web 28 can be transported through any further processing steps, such as oven 32, to result in the final asphalt product, such as mat 34, which is also shown in Figure 4. Further processing steps could also include laminating the asphalt fiber mat or layer with a reinforcement layer, such as a glass fiber mat. The asphalt fiber mat is porous, having a porosity within the range of from about 20 (9.4  $10^{-3}$  m<sup>3</sup>/s) to about 50 CuFt./min. (23.6  $10^{-3}$  m<sup>3</sup>/s) on a 1-inch square (0.645  $10^{-3}$  m<sup>2</sup>) sample with a one-half inch water pressure (0.93 mm of Hg) drop.

10 Preferably the asphalt fiber mat has a porosity within the range of from about 30 (1420  $10^{-3}$  m<sup>3</sup>/s) to about 40 CuFt./min. (1890  $10^{-3}$  m<sup>3</sup>/s). The mat has a density within the range of from about 2 (32 kg/m<sup>3</sup>) to about 10 pounds per cubic feet (pcf) (160 kg/m<sup>3</sup>), and preferably within the range of from about 3 (48 kg/m<sup>3</sup>) to about 5 pcf (80 kg/m<sup>3</sup>). The mat has a high degree of flexibility and conformability (ability to be molded or shaped around

15 sharp corners) when compared to an asphalt film of the same density or thickness.

An optional feature of the invention is the use of a heating means, such as induction heater 35, to heat either the asphalt spinner, or the primary asphalt fibers, or both, to facilitate the asphalt fiber attenuation. By heating the primary asphalt fibers, the process of further attenuation into the final asphalt fibers is enhanced. Even without the

20 need for secondary attenuation by the blower, an auxiliary heat source can be used to maintain the temperature of the asphalt spinner at the level for optimum centrifugation of the asphalt into fibers. Other heating means for the asphalt spinner can be employed, such as electric resistance heating. The temperature of the asphalt spinner should be within the range of from about 270°F (132°C) to about 500°F (260°C), and preferably within the

25 range of from about 330°F (165°C) to about 420°F (216°C).

#### Example I

Venezuelan Lagovan flux was oxidized in a converter to a softening point of 240°F (115°C). At this softening point the asphalt had a viscosity at 350°F (177°C) of 4,300 cps (4.3 Pa·s) and a penetration of 17 dmm at 25°C, as measured by ASTM D-5.

30 The oxidation was advanced sufficiently to be able to form fibers, but not so far as to cause the asphalt to become brittle at room temperature. No filler was added to the asphalt. The asphalt was heated in a hot melt heater prior to delivery to the asphalt spinner, and

delivered to the asphalt spinner at a temperature of 350°F (177°C). The asphalt spinner had a diameter of 15 inches (381 mm) and was rotated at 2300 RPM. The spinner peripheral wall was adapted with 854 orifices, each being 0.034 inches (0.86 mm) in diameter. There was no external heating from a burner and no secondary attenuation from  
5 a blower. The asphalt fibers were collected as a porous mat.

#### Example II

The oxidized Lagovan flux of Example I was further modified with 4 percent Kraton 1184. The polymer was incorporated into the asphalt by mixing in a Ross shear mixer at 400°F (204°C) for about 60 minutes. The resulting modified asphalt had a  
10 viscosity at 350°F (177°C) of 110,000 cps (110 Pa·s), a softening point of 285°F (141°C), and a penetration of 14 dmm at 25°C. The asphalt was delivered at a temperature of 400°F (204°C) to the asphalt spinner of Example I rotating at 1700 RPM, and asphalt fibers were centrifuged. These fibers were noticeably longer, stronger, and less tacky than the fibers from Example I.

15

#### Example III

A mixture of 96 percent Lagovan flux (softening point 104°F [40°C]) and 4 percent Kraton 1102 was air blown at 475°F (246°C) for 3 hours and 50 minutes. The resulting asphalt had a softening point of 244°F (118°C), a penetration of 20 dmm at 25°C, and a viscosity at 350°F (177°C) of 11,250 cps (11.25 Pa·s). The asphalt was further  
20 processed by heat conditioning at 330°F (166°C) for 2 hours to raise the viscosity, resulting in an asphalt having a softening point of 245°F (118°C), and a viscosity at 350°F (177°C) of 26,900 cps (26.9 Pa·s). The asphalt was delivered at a temperature of 360°F (182°C) to the asphalt spinner of Example I rotating at 1356 RPM. The resulting asphalt fibers were an open-type web.

25

#### Example IV

The oxidized Lagovan flux of Example I was modified by mixing it with 10 percent Himont Profax 6301 polypropylene in a shear mixer. The resulting asphalt had a softening point of 302°F (150°C), a penetration of 7 dmm at 25°C, and a viscosity at 350°F (177°C) of 110,000 cps (110 Pa·s). The asphalt was delivered at a temperature of 409°F  
30 (209°C) to the asphalt spinner of Example I rotating at 1229 RPM. The resulting asphalt fibers were drier, less tacky, and more lofty than any of the asphalt fiber samples from Examples I through III.

### Example V

The diameter of asphalt fibers produced in Examples I through IV was measured by first preparing a sample by fixing a 1-inch (25.4-mm) by 1.5-inch (38.1-mm) thin asphalt fiber mat specimen on a microscope slide with a cover slip. The microscope was equipped with 200X capability, a video camera, and a monitor. Transmitted light was used for all measurements in a bright field mode. A pair of dial calipers capable of measuring to 0.1 mm and a calibration slide with divisions of at least 10 microns and a total length of at least 100 microns was used. The calibration slide was placed on the stage, and 100 microns was measured off the video monitor using the dial calipers. From this measurement, a relationship was calculated from the actual size of the scale (100 microns) and the measured size from the monitor. The sample slide was then placed on the stage and 100 fibers were measured off the monitor. Only fibers which were separate from their neighbors (not fused or closely entangled) were measured. The actual fiber diameters were calculated, based on the calibration data, and averaged. As used in this specification, the term "having a diameter" within a certain range means that about 95 percent of the asphalt fibers in a random sample have a diameter within that specified range.

The results of asphalt fiber diameter measurements are shown in Table I. The capability to measure asphalt fiber diameters using the above method is made more difficult because of the black color of the asphalt. Because of this it is difficult to discern which fibers, if any, are twinned (fused along the axis) or otherwise closely entangled. For this reason the measurements shown in Table I may be skewed toward higher values than actually measured. Because of differences in the asphalt formulations, some samples have a natural tendency to fuse or twin more than others.

As a comparison, fiber diameters from a dried bottle grade polyethyleneterphthalate (PET) sample made by a similar rotary fiberizing process are included as a control in Table I. The PET material used was Eastman Kodapet dried at 230°C overnight. The PET fibers were made by centrifuging molten PET delivered at 600°F (316°C) to a 15-inch (318-mm) diameter spinner with 2400 holes having a diameter of 0.016 inch (0.406 mm). The spinner was rotated at 1600 RPM. The PET fibers exhibited some fusing and entangling. Some of the PET fibers were twinned, and the fibers exhibited brashiness (lack of slipperiness when rubbing one fiber against another).

**Example VI**

The asphalt of Example II was enhanced by the addition of clay filler to make up 10 percent of the total composition by weight. The fibers were stiffer than the fibers produced in Example II, and were also drier and shorter. Preferably the amount of filler is within the range of from about 2 to about 30 percent by weight of the total weight of asphalt and filler.

Table I

**FIBER DIAMETER DISTRIBUTION**

Sample	Avg. Fiber Diameter Ht ( $10^{-3} \text{m}^3/\text{s}$ )	Standard Deviation
Example II	31 (14.6)	16
Example IV	68 (32.1)	28
Example V	23 (10.9)	9
Example VI	36 (17.0)	19

The process for fiberizing asphalt with a rotating asphalt spinner can be used in combination with a rotary glass fiber forming process to integrate asphalt with glass fibers. As shown in Figure 2, the asphalt spinner 10 is positioned beneath a conventional glass spinner 40 of the type well known for producing glass fibers. The asphalt spinner is preferably mounted beneath the glass spinner bottom wall for coaxial rotation with the glass spinner on axis 42. Molten asphalt stream 20 drops through hollow quill 44 which rotatably supports the glass spinner. Attenuation of the glass fibers can be facilitated by annular blower 46 and annular burner 36, in a manner well known in the art of making glass fibers.

Molten glass is dropped as stream 50 into the spinner, is centrifuged as glass fibers 52 and turned downwardly as a flow of fibers and gases, or veil 54. An additive apparatus, such as binder nozzle 56, can be positioned either within the veil or outside the veil, for applying any binder or other coatings or particles desired, or for supplying liquids for cooling the asphalt fibers.

In operation the asphalt fibers are distributed radially outwardly from the asphalt spinner, and they intermingle with the glass fibers in the veil and are collected on the conveyor as an intermingled mass 58 of asphalt fibers and glass fibers. Since the glass

fiber forming process necessarily operates at temperatures above the softening point of glass, the area surrounding and immediately below the glass spinner is very hot. It is possible that some of the asphalt fibers will be entrained in some of the hot gases flowing with the veil of fibers, and thereby experience temperatures sufficient to soften or melt the asphalt fibers. In such a case, some of the asphalt material may attach itself to some of the glass fibers to form asphalt particles on the fibers. The asphalt may also be in the form of a coating on some of the fibers. Care must be taken not to introduce the asphalt into a region with temperatures so hot as to ignite the asphalt. The mass of intermingled asphalt and glass fibers can be transported to any suitable processing station, such as oven 32, before becoming asphalt/glass fiber product 60.

Example VII

The asphalt sample of Example IV was cofiberized with glass fibers with apparatus similar to that shown in Figure 2. The resulting mass of intermingled asphalt and glass fibers was collected as an insulation product, which looked like black fiberglass insulation. The asphalt/glass fiber insulation product had between 60 and 65 percent by weight organic components, although the weight percent of the organic components can be within the range of from about 20 to about 80 percent of the asphalt/glass fiber commingled product. Four individual samples were prepared, with the results shown in Table II.

Table II

ASPHALT/GLASS FIBER INSULATION PROPERTIES

Sample	Thickness Inches (mm)	Weight (grams)	Density pcf (kg/m <sup>3</sup> )	Thermal Conductivity k (w/m.K)	Thermal Resistivity R (Km <sup>2</sup> /W)
1	0.8 (20.3)	70	2.13 (34.12)	0.236 (0.0340)	3.39 (0.597)
2	0.8 (20.3)	72	2.19 (35.08)	0.237 (0.0341)	3.37 (0.593)
3	1.0 (25.4)	145	3.54 (56.71)	0.231 (0.0333)	4.33 (0.763)
4	1.0 (25.4)	138	3.36 (52.82)	0.235 (0.0339)	4.26 (0.750)

As an alternative to the coaxial fiberizing explained above and shown in Figure 2, alternate commingling of veils of asphalt fibers and glass fibers can also be used, as shown in Figure 3. The asphalt fibers can be integrated with the glass fibers by

centrifuging glass fibers from one or more rotary glass spinners 40 which are supplied with molten glass by any suitable delivery means, such as forehearth 66, to establish one or more downwardly moving veils 54 of glass fibers. The glass fiber veils are positioned above collecting surface 30, and the veils of glass fibers are aligned generally along the length of the collecting surface. Asphalt fibers are centrifuged by one or more rotary asphalt spinners 10 to establish one or more downwardly moving veils 25 of asphalt fibers also positioned above the collecting surface. The asphalt material can be supplied in molten form from a common source, such as asphalt supply conduit 68. The veils of asphalt fibers are aligned along the length of the collecting surface, generally colinearly with the veils of glass fibers, in an alternating fashion with the veils of glass fibers. The result is that the asphalt fibers and glass fibers intermingle and are collected as integrated asphalt fibers and glass fibers. Subsequently, the integrated asphalt and glass fibers can be further processed into the desired asphalt/glass fiber product. In an alternative embodiment, a single asphalt spinner is positioned between a pair of glass spinners.

The asphalt fiber mat 34 of the invention, shown in Figure 4, can be incorporated into numerous applications, particularly in the construction industry. Possible uses include glass mat thermoplastics, filtration, sound absorption, gasketing, sorbents, adhesives, mat binders, moisture resistant layers, corrosion resistant layers, insulation, polymer placement for shingle modification, application of a conforming layer without the need for heating or a solvent, impact absorbing layers, and highway resurfacing.

The integrated glass fibers and asphalt can be subjected to a compressing or consolidation step which forms a more dense product. Prior to consolidation the integrated glass fibers and asphalt preferably have a density within the range of from about 2 (32 kg/m<sup>3</sup>) to about 15 pcf (240 kg/m<sup>3</sup>), while after consolidation the integrated glass fiber and asphalt product preferably has a density within the range of from about 65 (1041 kg/m<sup>3</sup>) to about 120 pcf (1922 kg/m<sup>3</sup>). The consolidated product will have uses in various products including vibration damping material, molding material, insulation, and floor tile substrates.

When the asphalt fiber mat is used in highway construction and repair, the asphalt fiber mat can be laminated with reinforcement mats, such as a wet process glass fiber mat, to form a reinforcement layer. The reinforcement layer is useful in various other construction applications as well as highway construction. As shown in Figure 5, a laminated mat 70 can be formed by laminating together asphalt mat 34 and a reinforcement

layer, such as continuous glass fiber mat 72. The laminated mat can be used as a stress-absorbing membrane interlayer in various construction applications, such as highways.

The use of the asphalt fiber mat in a shingle process is shown in Figure 6, in which wet process shingle mat 76 and asphalt fiber layer 34 are laminated together to form laminated mat 70. The laminated mat is fed into asphalt coater 78, and granules are applied to the coated asphalt sheet by granule applicator 80. The granules are pressed into the sheet in any suitable manner, such as granule press 82, and are cut into individual shingles 84 by cutting cylinder 86. An individual shingle is shown in Figure 7. After the discrete shingles are formed, they can be processed with commonly used apparatus for handling such shingles, such as shingle stacker 88 to form stacks 90 of shingles, and bundle packager 92 to form shingle bundles 94. The use of a layer of asphalt fibers in the construction of a shingle or other roofing product enables the selective positioning of a layer having specific properties. For example, if the asphalt fibers in the layer are modified with a polymer to provide high flexibility or elasticity, the use of the layer enables placement of high elasticity asphalt at the top portion of the shingle (where elasticity is needed) without requiring all of the coating asphalt to be modified. This construction would give a better performing shingle without much additional cost.

#### Example VIII

Asphalt roofing shingles were made by laminating an asphalt fiber layer made as in Example II above with a wet process shingle mat. The laminated mat was then coated with filled coating asphalt to make a shingle. The Elmendorf tear strength of the resulting shingle was 1953 grams. This is about 9 percent higher than the typical tear strength for conventional shingles.

The process for making highway reinforcement products shown in Figure 8 includes glass spinner 100 mounted for coaxial rotation with first asphalt spinner 102. Molten glass 104 supplied to the spinner is centrifuged from the glass spinner in the form of glass fibers 106. Molten asphalt 108 supplied to the first asphalt spinner is centrifuged into asphalt fibers 110 by the first asphalt spinner. The asphalt fibers preferably have a diameter within the range of from about 25 (635  $10^3\mu\text{m}$ ) to about 60 Ht (1524  $10^3\mu\text{m}$ ). This cofiberizing of the glass fibers and the asphalt fibers commingles the two materials and



integrates them with each other. The glass fibers and the asphalt fibers can be turned downwardly by annular blowers, not shown.

The glass spinner and first asphalt spinner are positioned above a collecting surface, such as conveyor 112. Where desired, a reinforcement mat, such as open weave  
5 glass grid 114, can be fed onto the conveyor and directed beneath the flow of integrated asphalt and glass fibers. The reinforcement mat can be any type suitable for reinforcing pavement layers, either woven or nonwoven, of organic or inorganic materials, and preferably in the form of an open weave or grid. The integrated asphalt and glass fibers are collected on top of the glass grid to produce highway reinforcement product 116.  
10 Preferably, the integrated asphalt and glass fibers are consolidated by calendaring roll 117.

Optionally, tack coating material 118 can be applied to the top of the highway reinforcement product from any suitable source, such as tack coat spray applicator 120. The tack coat can be any suitable adhesive for bonding the highway reinforcement product to the roadway, such as an asphalt adhesive. Preferably, the tack coat is tacky at a  
15 temperature of 25°C, as measured by ASTM rolling ball test D-2131, according to which values above about 40 mm are considered not tacky.

An optional procedure to apply a tack coat is shown in Figure 8. A second layer of asphalt fibers 126 produced by second asphalt spinner 128 can be laid down on top of the highway reinforcement product. Preferably, the second asphalt spinner is in general  
20 alignment with the first asphalt spinner along the length of the collecting surface. The asphalt stream 130 being supplied to the second asphalt spinner is of a composition which will create tacky fibers. This can be accomplished in several ways, such as by using an asphalt with a high penetration ratio. Preferably, the tacky asphalt fibers have a diameter within the range of from about 25 (635 10<sup>3</sup>µm) to about 60 Ht (1524 10<sup>3</sup>µm). When the  
25 tacky coating or layer is applied in the form of tacky asphalt fibers, the spray applied tack coat 118 is usually not necessary. Preferably, the tacky asphalt fibers are tacky at a temperature of 25°C.

As shown in Figure 9, the highway reinforcement product 116 has reinforcement mat or glass grid 114 as its top layer, since as applied to the highway the  
30 product is inverted from the orientation shown in Figure 8. In the middle of the product is layer 122 which is the integrated glass fibers 106 and asphalt fibers 110. The bottom layer

is tack coat 118. Finally, the highway reinforcement product can contain release paper 124 to facilitate unwinding the product at the highway paving site.

It will be evident from the foregoing that various modifications can be made to this invention. Such, however, are considered as being within the scope of the invention.

5

INDUSTRIAL APPLICABILITY

The invention can be useful in the manufacture of reinforcement products of asphalt and glass fibers, and in the manufacture of asphalt roofing shingles.

10

15

20

25

30

**CLAIMS**

1. A method for integrating asphalt with reinforcement fibers comprising:
  - a. establishing a downwardly moving veil of reinforcement fibers  
5 of heat-softenable material;
  - b. supplying molten asphalt to a rotating asphalt spinner positioned within the veil of reinforcement fibers;
  - c. centrifuging asphalt fibers from the asphalt spinner, thereby directing the asphalt fibers into engagement with the veil to integrate the asphalt with  
10 the reinforcement fibers; and,
  - d. collecting the integrated asphalt and reinforcement fibers.
2. The method of claim 1 comprising supplying the molten asphalt to the asphalt spinner at a temperature within the range of from about 270°F (132°C) to about 500°F (260°C).
- 15 3. The method of claim 1 in which the supplying step comprises supplying asphalt modified with one or more organic modifiers from the group consisting of natural rubber, synthetic rubber, elastomers, polymers, resins, and other thermoplastic or thermoset materials, the modifiers being present in an amount within the range of from about 2 to about 30 percent.
- 20 4. The method of claim 3 in which the modifiers are present in an amount within the range of from about 4 to about 12 percent.
5. The method of claim 3 comprising supplying the molten asphalt to the asphalt spinner at a temperature within the range of from about 270°F (132°C) to about 500°F (260°C).
- 25 6. The method of claim 1 in which the supplying step comprises supplying asphalt which has been subjected to an oxidizing process sufficient to give the asphalt a softening point within the range of from about 180°F (82°C) to about 350°F (177°C).
7. The method of claim 6 comprising supplying the molten asphalt to the  
30 asphalt spinner at a temperature within the range of from about 270°F (132°C) to about 500°F (260°C).

8. The method of claim 1 in which the centrifuging step provides acceleration to the molten asphalt sufficient to produce primary asphalt fibers having a diameter less than about 250 Ht ( $6350 \cdot 10^3 \mu\text{m}$ ).
9. The method of claim 1 in which the asphalt spinner has a peripheral  
5 wall with between about 500 and 25,000 orifices through which the asphalt is centrifuged.
10. A method for integrating asphalt with reinforcement fibers comprising:
- a. centrifuging glass fibers from a rotating glass spinner containing molten glass to establish a downwardly moving veil of glass fibers;
  - 10 b. supplying molten asphalt at a temperature within the range of from about 270°F (132°C) to about 500°F (260°C) to a rotating asphalt spinner positioned within the veil of glass fibers;
  - c. centrifuging asphalt fibers from the asphalt spinner, thereby directing the asphalt fibers into engagement with the veil to integrate the asphalt with  
15 the glass fibers; and,
  - d. collecting the integrated asphalt and glass fibers.
11. The method of claim 10 in which the supplying step comprises supplying asphalt modified with one or more organic modifiers from the group consisting of natural rubber, synthetic rubber, elastomers, polymers, resins, and other thermoplastic or  
20 thermoset materials, the modifiers being present in an amount within the range of from about 2 to about 30 percent.
12. The method of claim 11 in which the modifiers are present in an amount within the range of from about 4 to about 12 percent.
13. The method of claim 10 comprising supplying the molten asphalt to  
25 the asphalt spinner at a temperature within the range of from about 270°F (132°C) to about 500°F (260°C).
14. The method of claim 10 in which the supplying step comprises supplying asphalt which has been subjected to an oxidizing process sufficient to give the asphalt a softening point within the range of from about 200°F (93°C) to about 270°F  
30 (132°C).

15. The method of claim 10 in which the centrifuging step provides acceleration to the molten asphalt sufficient to produce primary asphalt fibers having a diameter within the range of from about 25 (635  $10^3\mu\text{m}$ ) to about 60 Ht (1524  $10^3\mu\text{m}$ ).
16. The method of claim 10 in which the asphalt spinner has a peripheral  
5 wall with between about 500 and about 25,000 orifices through which the asphalt is centrifuged.
17. A method for integrating asphalt with reinforcement fibers comprising:
- 10 a. centrifuging glass fibers from one or more rotary glass spinners to establish one or more downwardly moving veils of glass fibers positioned above a collecting surface, the veils of glass fibers being aligned generally along the length of the collecting surface;
- 15 b. centrifuging asphalt fibers from one or more rotary asphalt spinners to establish one or more downwardly moving veils of asphalt fibers positioned above the collecting surface, the veils of asphalt fibers being aligned generally along the length of the collecting surface, the veils of asphalt fibers alternating with the veils of glass fibers along the length of the collecting surface to integrate the asphalt fibers and the glass fibers; and,
- 20 c. collecting the integrated glass fibers and asphalt fibers on the collecting surface.
18. The method of claim 17 in which the supplying step comprises supplying asphalt modified with one or more organic modifiers from the group consisting of natural rubber, synthetic rubber, elastomers, polymers, resins, and other thermoplastic or thermoset materials, the modifiers being present in an amount within the range of from  
25 about 2 to about 30 percent.
19. The method of claim 18 in which the modifiers are present in an amount within the range of from about 4 to about 12 percent.
20. The method of claim 17 comprising supplying the molten asphalt to the asphalt spinner at a temperature within the range of from about 270°F (132°C) to about  
30 500°F (260°C).
21. The method of claim 17 in which the supplying step comprises supplying asphalt which has been subjected to an oxidizing process sufficient to give the

asphalt a softening point within the range of from about 200°F (93°C) to about 270°F (132°C).

22. The method of claim 17 in which the centrifuging step provides acceleration to the molten asphalt sufficient to produce primary asphalt fibers having a diameter within the range of from about 25 (635  $10^3\mu\text{m}$ ) to about 60 Ht (1524  $10^3\mu\text{m}$ ).
23. The method of claim 17 in which the asphalt spinner has a peripheral wall with between about 500 and about 25,000 orifices through which the asphalt is centrifuged.
24. The method of claim 17 in which the integrated glass fibers and asphalt have a density within the range of from about 2 (32  $\text{kg}/\text{m}^3$ ) to about 15 pcf (240  $\text{kg}/\text{m}^3$ ).
25. The method of claim 17 including a step of consolidating the integrated glass fibers and asphalt to form a product having a density within the range of from about 65 (1041  $\text{kg}/\text{m}^3$ ) to about 120 pcf (1922  $\text{kg}/\text{m}^3$ ).
26. An integrated glass fiber and asphalt fiber product made by the method of claim 1.
27. The integrated glass fiber and asphalt fiber product of claim 26 in which the weight percent of the organic components is within the range of from about 20 to about 80 percent of the total product.
28. The integrated glass fiber and asphalt fiber product of claim 27 in which the weight percent of the organic components is within the range of from about 60 to about 65 percent of the total product.
29. An integrated glass fiber and asphalt fiber product made by the method of claim 17.
30. The integrated glass fiber and asphalt fiber product of claim 29 in which the weight percent of the organic components is within the range of from about 20 to about 80 percent of the total product.
31. The integrated glass fiber and asphalt fiber product of claim 30 in which the weight percent of the organic components is within the range of from about 60 to about 65 percent of the total product.
32. An integrated glass fiber and asphalt fiber product made by the method of claim 24.

33. An integrated glass fiber and asphalt fiber product made by the method of claim 25.

5

10

15

20

25

30

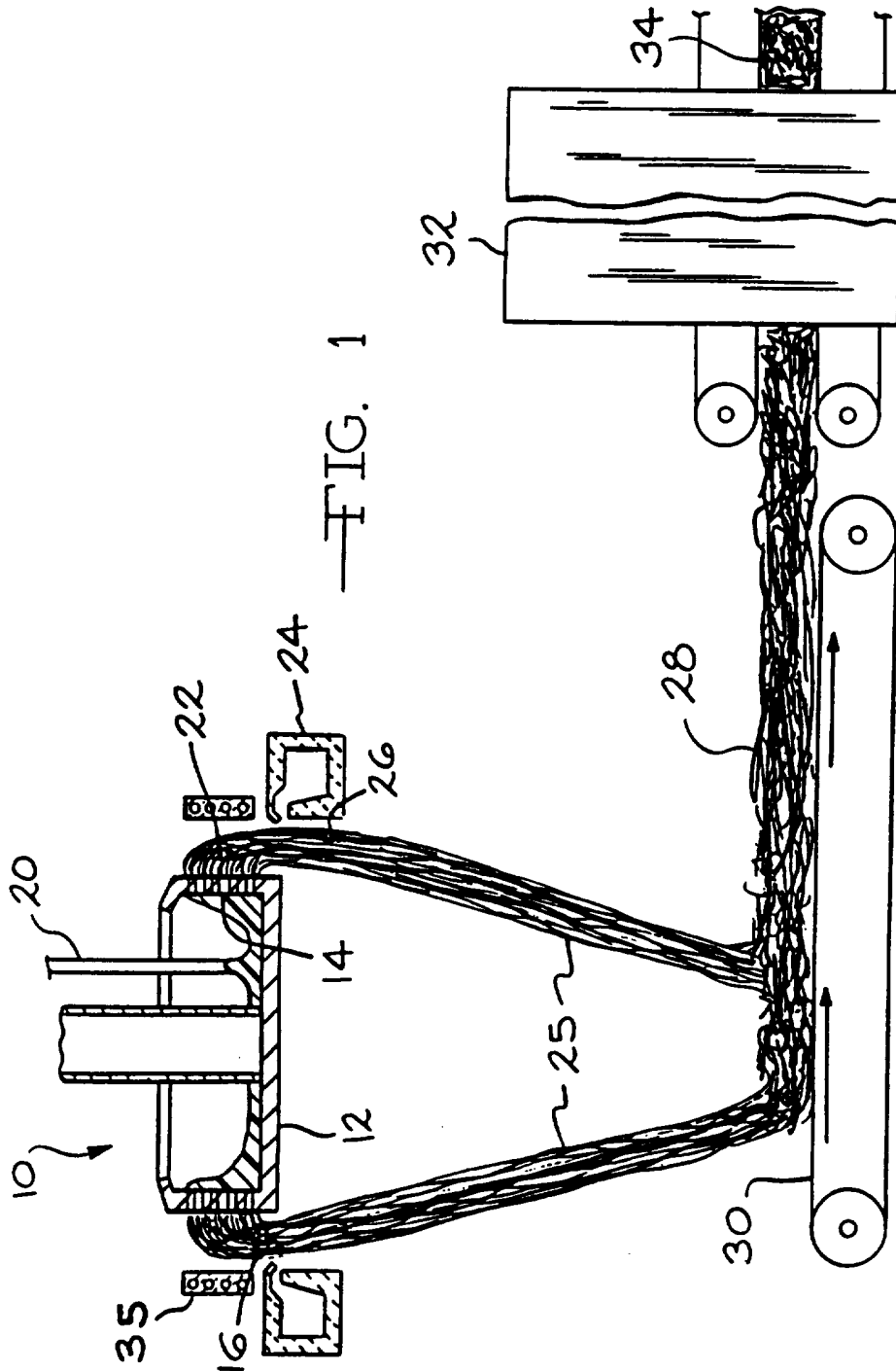
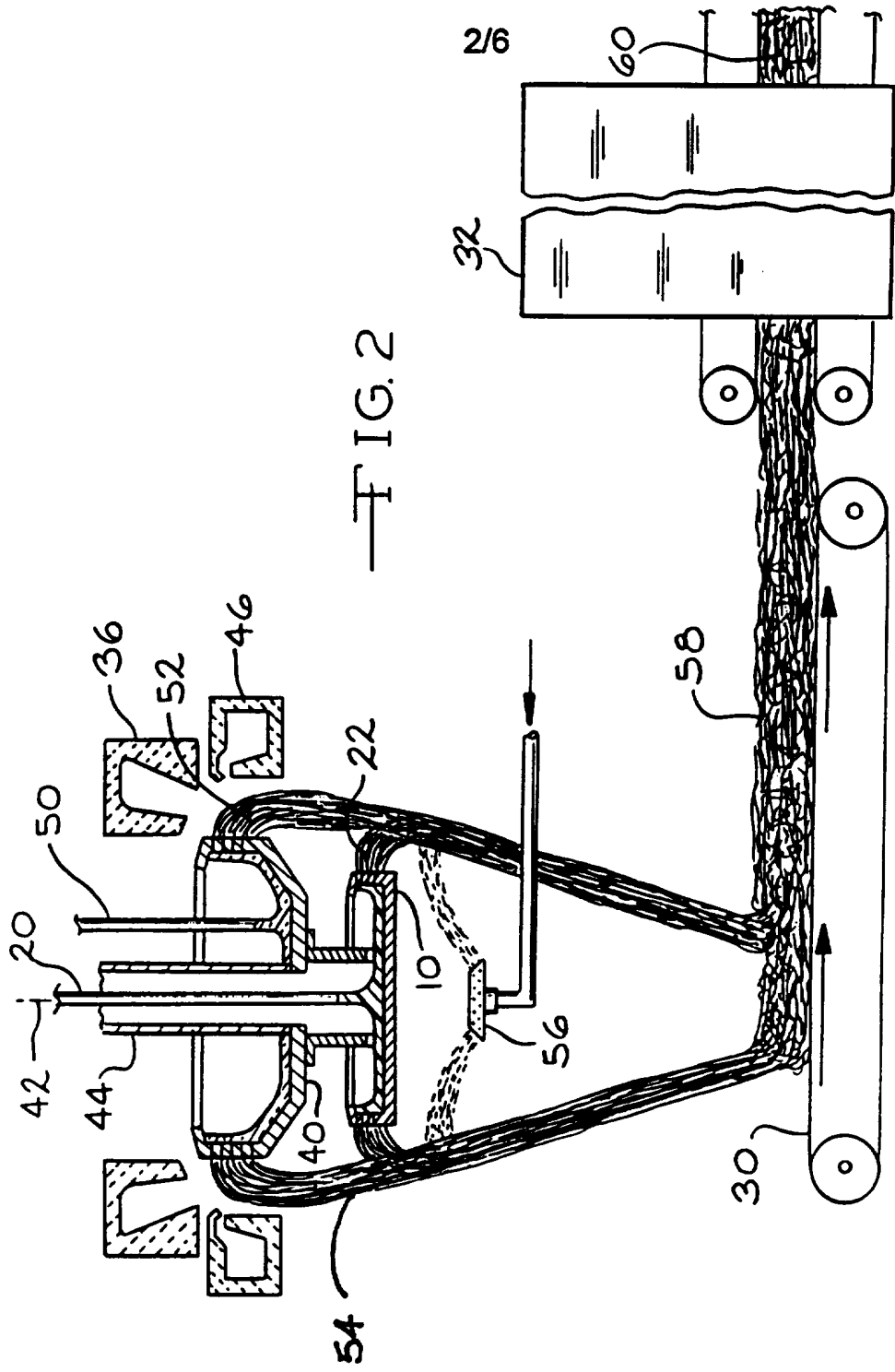

FIG. 1





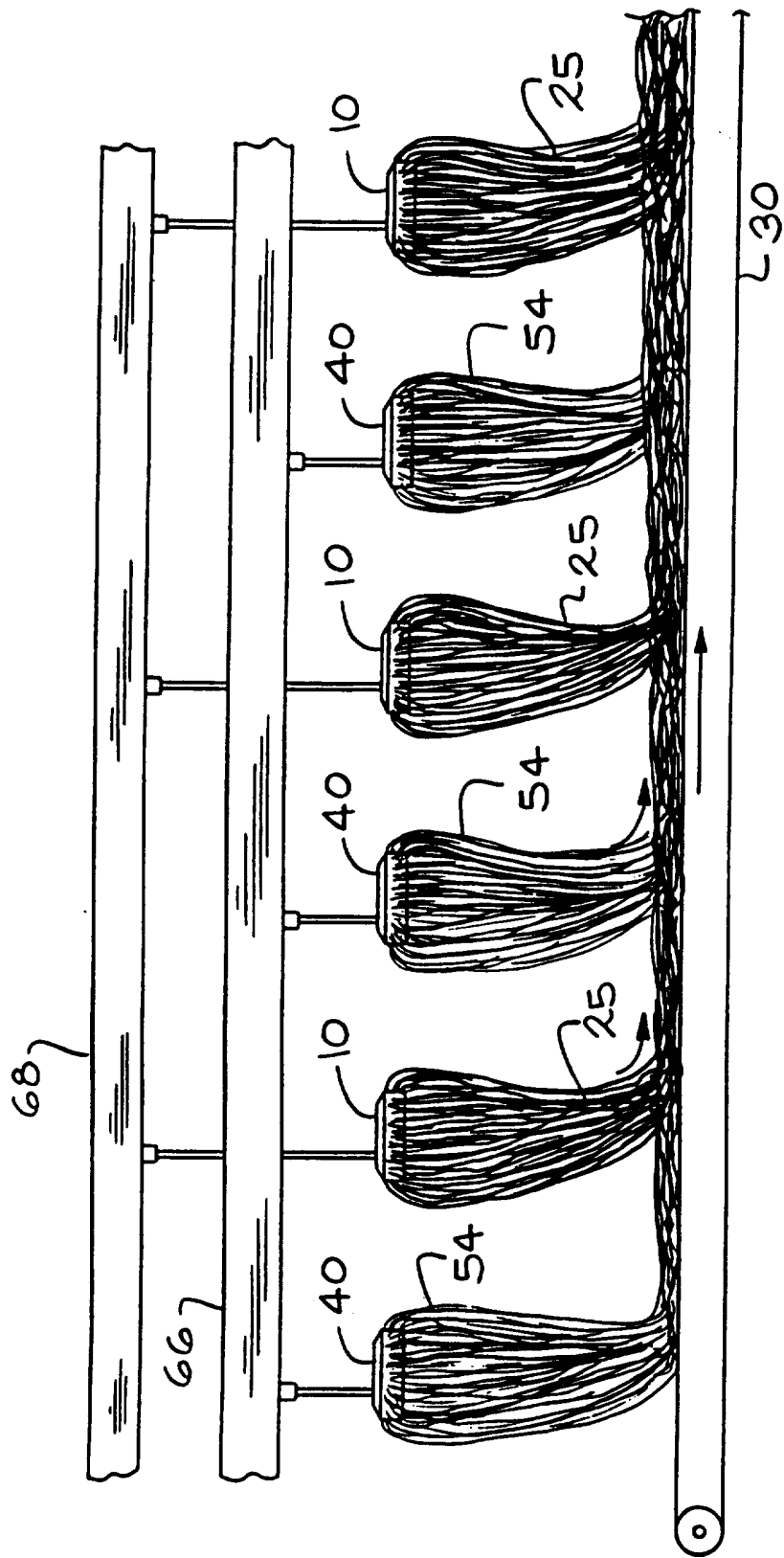

FIG. 3

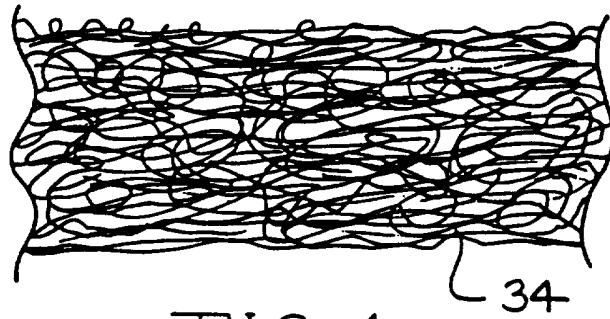

FIG. 4

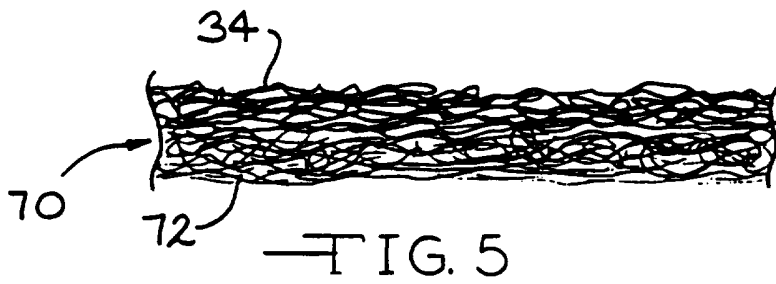

FIG. 5

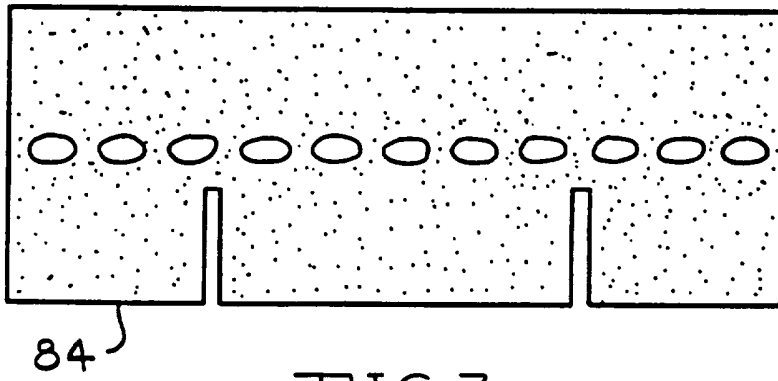

FIG. 7

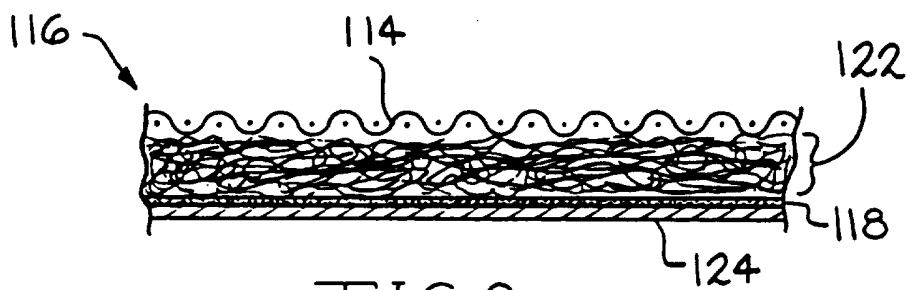

FIG. 9

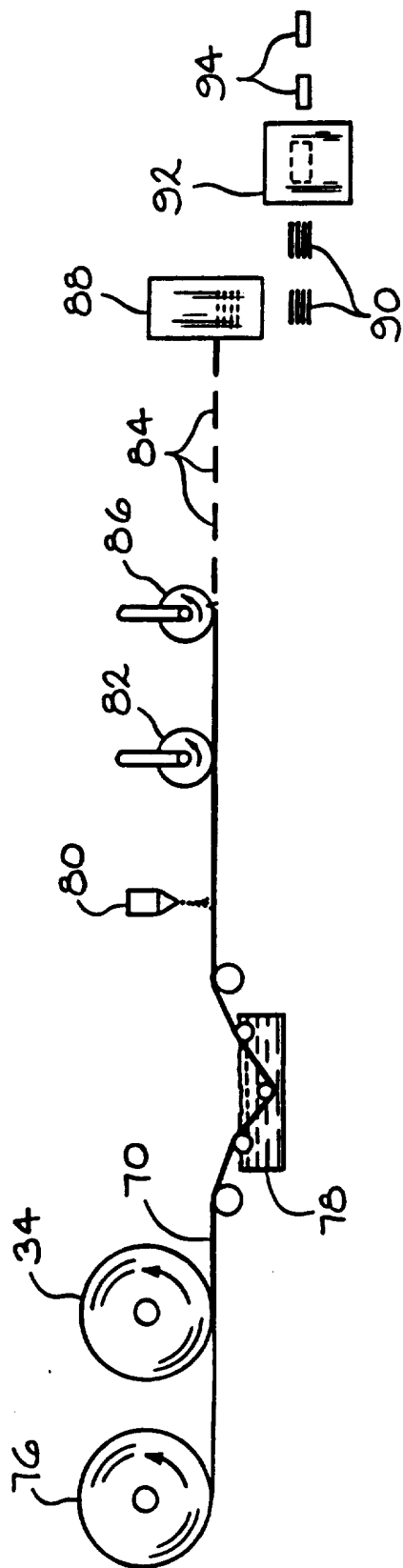

FIG.6

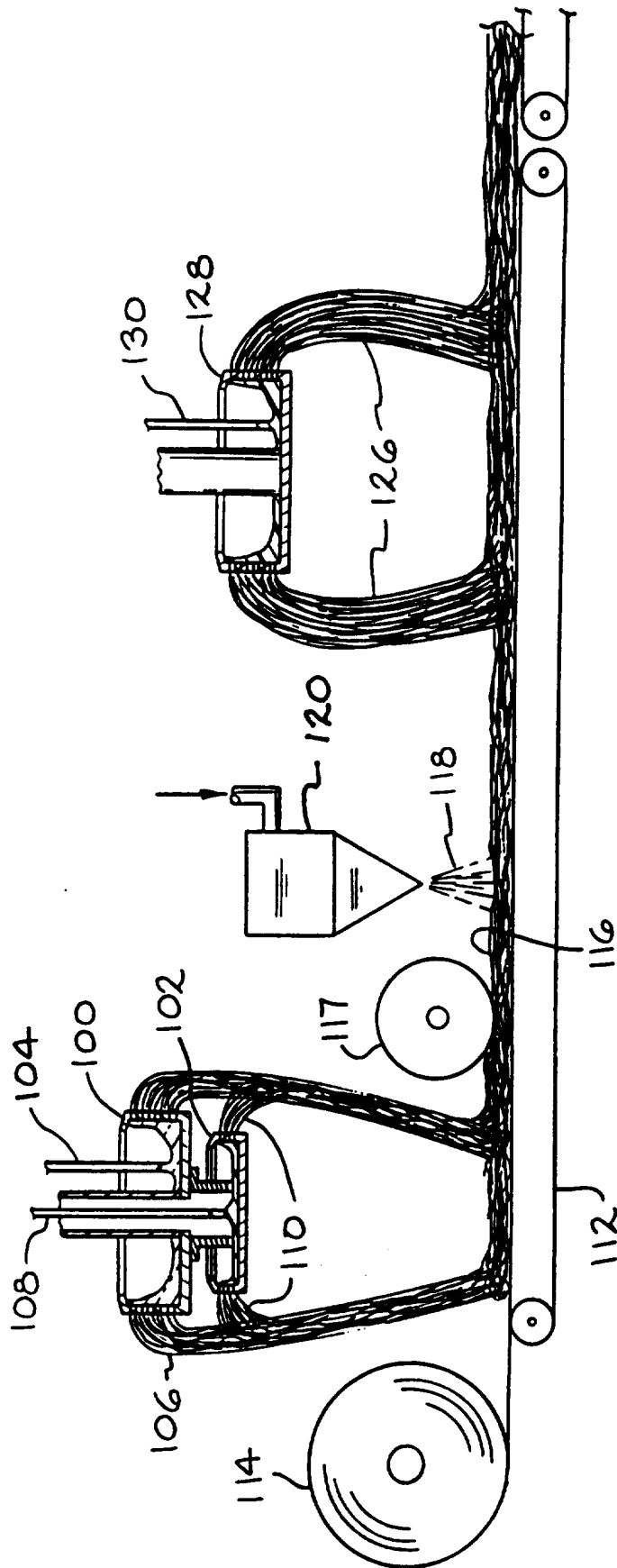

FIG. 8

# INTERNATIONAL SEARCH REPORT

International Application No  
PCT/US 95/14232

A. CLASSIFICATION OF SUBJECT MATTER  
IPC 6 B29C70/50 B29B15/10 D01D5/18 C03C25/02

According to International Patent Classification (IPC) or to both national classification and IPC

**B. FIELDS SEARCHED**

Minimum documentation searched (classification system followed by classification symbols)

IPC 6 B29C B29B D01D C03C C03B C10C

Documentation searched other than minimum documentation to the extent that such documents are included in the fields searched

Electronic data base consulted during the international search (name of data base and, where practical, search terms used)

**C. DOCUMENTS CONSIDERED TO BE RELEVANT**

Category *	Citation of document, with indication, where appropriate, of the relevant passages	Relevant to claim No.
A	EP,A,0 367 661 (SAINT GOBAIN VETROTEX) 9 May 1990 see claim 1; figure 1 ---	1-25
A	EP,A,0 554 119 (PETOCA LTD) 4 August 1993 see column 7, line 10 - line 14; examples 1,3 ---	1-25
A	DATABASE WPI Section Ch, Week 7615 Derwent Publications Ltd., London, GB; Class F09, AN 76-27579X & JP,A,51 024 680 ( NIPPON HARD BOARD) , 28 February 1976 see abstract ---	1-25
	-/--	

Further documents are listed in the continuation of box C.

Patent family members are listed in annex.

\* Special categories of cited documents :

- \*A\* document defining the general state of the art which is not considered to be of particular relevance
- \*E\* earlier document but published on or after the international filing date
- \*L\* document which may throw doubts on priority claim(s) or which is cited to establish the publication date of another citation or other special reason (as specified)
- \*O\* document referring to an oral disclosure, use, exhibition or other means
- \*P\* document published prior to the international filing date but later than the priority date claimed

- \*T\* later document published after the international filing date or priority date and not in conflict with the application but cited to understand the principle or theory underlying the invention
- \*X\* document of particular relevance; the claimed invention cannot be considered novel or cannot be considered to involve an inventive step when the document is taken alone
- \*Y\* document of particular relevance; the claimed invention cannot be considered to involve an inventive step when the document is combined with one or more other such documents, such combination being obvious to a person skilled in the art
- \*&\* document member of the same patent family

Date of the actual completion of the international search

1 March 1996

Date of mailing of the international search report

14 March 1996

Name and mailing address of the ISA

European Patent Office, P.B. 5818 Patentlaan 2  
NL - 2280 HV Rijswijk  
Tel. (+ 31-70) 340-2040, Tx. 31 651 epo nl,  
Fax: (+ 31-70) 340-3016

Authorized officer

Attalla, G

**INTERNATIONAL SEARCH REPORT**

International Application No  
PCT/US 95/14232

C.(Continuation) DOCUMENTS CONSIDERED TO BE RELEVANT		
Category	Citation of document, with indication, where appropriate, of the relevant passages	Relevant to claim No.
A	US,A,3 626 722 (CORSENTINO JOSEPH) 14 December 1971 see column 3, line 47 - line 51; figure 2 ---	1-25
A	DATABASE WPI Section Ch, Week 8542 Derwent Publications Ltd., London, GB; Class A32, AN 85-259702 & JP,A,60 173 113 ( NIPPON JIDOSHA BUHIN SOG) , 6 September 1985 see abstract ---	1-25
A	EP,A,0 193 846 (VITROFIL SPA) 10 September 1986 see claim 1; figure 1 ---	26-33
A	US,A,4 956 199 (RUISI SANTO J) 11 September 1990 see abstract; figure 3 ---	26-33
A	US,A,4 873 303 (BLACKWOOD ALBERT J ET AL) 10 October 1989 see claim 1; figure 1 ---	26-33
A	US,A,1 500 934 (HOOPER) 8 July 1924 see figure 2 ---	
P,A	WO,A,95 00453 (OWENS CORNING FIBERGLASS CORP) 5 January 1995 see the whole document ---	
E	US,A,5 468 546 (LOFTUS JAMES E ET AL) 21 November 1995 see the whole document -----	1-33

# INTERNATIONAL SEARCH REPORT

information on patent family members

International Application No

PCT/US 95/14232

Patent document cited in search report	Publication date	Patent family member(s)	Publication date
EP-A-0367661	09-05-90	FR-A- 2638467	04-05-90
		CA-A, C 2001694	28-04-90
		DE-T- 68907856	10-02-94
		ES-T- 2044182	01-01-94
		JP-A- 2160907	20-06-90
		NO-B- 174635	28-02-94
		US-A- 5011523	30-04-91
-----			
EP-A-0554119	04-08-93	JP-A- 5302217	16-11-93
		US-A- 5292473	08-03-94
-----			
US-A-3626722	14-12-71	NONE	
-----			
EP-A-0193846	10-09-86	NONE	
-----			
US-A-4956199	11-09-90	NONE	
-----			
US-A-4873303	10-10-89	NONE	
-----			
US-A-1500934	08-07-24	NONE	
-----			
WO-A-9500453	05-01-95	US-A- 5458822	17-10-95
		AU-B- 7170494	17-01-95
		CA-A- 2164213	05-01-95
-----			
US-A-5468546	21-11-95	NONE	
-----			