

(19) World Intellectual Property Organization
International Bureau



(43) International Publication Date
19 December 2002 (19.12.2002)

PCT

(10) International Publication Number
WO 02/102035 A2

- (51) International Patent Classification⁷: **H04M 1/247, 1/725**
- (21) International Application Number: PCT/EP02/06212
- (22) International Filing Date: 6 June 2002 (06.06.2002)
- (25) Filing Language: English
- (26) Publication Language: English
- (30) Priority Data:
0102050-2 11 June 2001 (11.06.2001) SE
60/298,625 15 June 2001 (15.06.2001) US
- (71) Applicant (for all designated States except US): **TELEFONAKTIEBOLAGET L M ERICSSON (PUBL)** [SE/SE]; S-126 25 Stockholm (SE).
- (72) Inventors; and
- (75) Inventors/Applicants (for US only): **WENDEL RUP,**

Heino [SE/SE]; Västra Rönneholmsvägen 73a, S-217 41 Malmö (SE). **BENGTSSON, Niklas** [SE/SE]; Riddarebacken 16, S-244 41 Kävlinge (SE). **JÖNSSON, Mikael** [SE/SE]; Fäladsgatan 24, S-254 54 Helsingborg (SE). **FROLOV, Sigge** [SE/SE]; Ringvägen 9, S-235 93 Vellinge (SE). **GUSTAVSSON, Carl** [SE/SE]; Kulgrändens 15 A, S-226 49 Lund (SE). **MELLQVIST, Anders** [SE/SE]; Mäster Henriksgatan 7f, S-211 58 Malmö (SE).

(74) Agent: **STRÖM & GULLIKSSON IPC AB**; P.O. Box 793, S-220 07 Lund (SE).

(81) Designated States (national): AE, AG, AL, AM, AT (utility model), AU, AZ, BA, BB, BG, BR, BY, BZ, CA, CH, CN, CO, CR, CU, CZ (utility model), DE (utility model), DK (utility model), DM, DZ, EC, EE (utility model), ES, FI (utility model), GB, GD, GE, GH, GM, HR, HU, ID, IL, IN, IS, JP, KE, KG, KP, KR, KZ, LC, LK, LR, LS, LT, LU, LV, MA, MD, MG, MK, MN, MW, MX, MZ, NO, NZ, OM, PH, PL, PT, RO, RU, SD, SE, SG, SI, SK (utility model),

[Continued on next page]

(54) Title: METHOD AND APPARATUS FOR PROVIDING ENHANCED ACCESSORY SUPPORT IN PORTABLE COMMUNICATION DEVICES

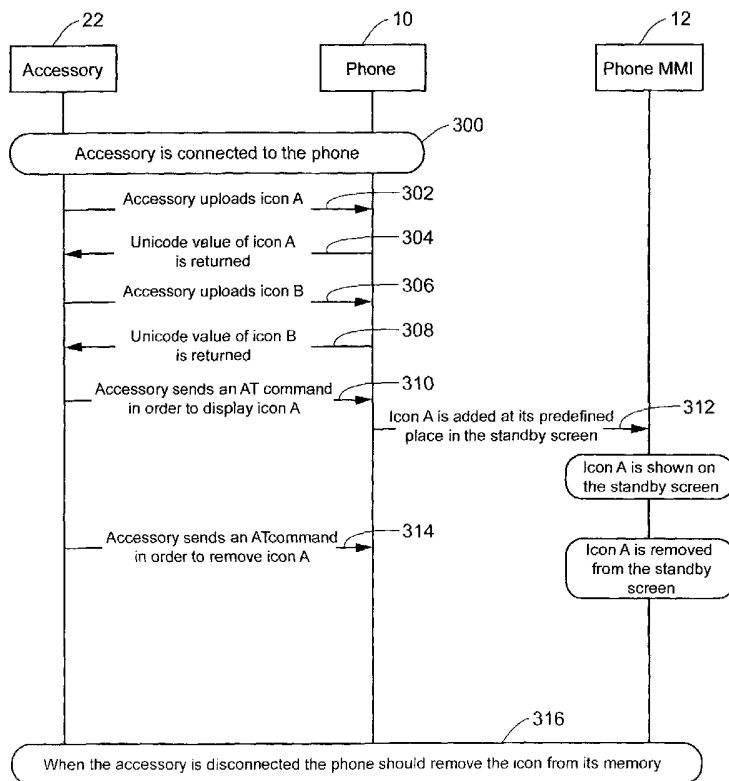

(57) Abstract: A method and apparatus for providing enhanced accessory support in a portable communication apparatus (10) primarily adapted for telecommunication is disclosed. An external accessory device (22) is attached to the portable communication apparatus (10) having a display (12) with a visual presentation area. Accessory information is sent from the external accessory device (22) to the portable communication apparatus (10) and the received accessory information is displayed in a subarea (54) of the display (12).



WO 02/102035 A2



SL, TJ, TM, TN, TR, TT, TZ, UA, UG, US, UZ, VN, YU,
ZA, ZM, ZW.

(84) Designated States (regional): ARIPO patent (GH, GM, KE, LS, MW, MZ, SD, SL, SZ, TZ, UG, ZM, ZW), Eurasian patent (AM, AZ, BY, KG, KZ, MD, RU, TJ, TM), European patent (AT, BE, CH, CY, DE, DK, ES, FI, FR, GB, GR, IE, IT, LU, MC, NL, PT, SE, TR), OAPI patent (BF, BJ, CF, CG, CI, CM, GA, GN, GQ, GW, ML, MR, NE, SN, TD, TG).

Published:

— *without international search report and to be republished upon receipt of that report*

For two-letter codes and other abbreviations, refer to the "Guidance Notes on Codes and Abbreviations" appearing at the beginning of each regular issue of the PCT Gazette.

APPLICANT: Telefonaktiebolaget L M Ericsson (publ)
TITLE: Method and Apparatus for Providing Enhanced
Accessory Support in Portable Communication
5 Devices

Field of the Invention

The present invention relates to a method and
10 apparatus for providing enhanced accessory support for
accessories connected to portable communication devices
primarily adapted for telecommunication.

Background of the Invention

15 It is usual within rapidly growing technical fields
to provide a portable communication apparatus, such as a
telephone for instance, with additional equipment that has
been produced subsequent to the production of the portable
communication apparatus. When there is little or no support
20 for later produced equipment, the additional equipment and
other auxiliaries function to only a limited extent with
the earlier produced portable communication apparatus, or
sometimes not at all. When there is a need to be able to
use later produced additional equipment with the older
25 portable communication apparatus, it is necessary to be
able to operate the additional equipment from the portable
communication apparatus. This presents a problem, of
course, since the additional equipment was not known at the
time the portable communication device was produced.

30 Furthermore, many accessories would benefit from
being able to use the display, keypad and speaker
(man/machine interface MMI) of the portable communication
apparatus to interact with users in ways that are not known
in detail when the portable communication apparatus is
35 manufactured.

Most portable communication apparatus have various
menus which can be selected to help the user select various
functions. The menu structure of the portable communication

apparatus is known to include accessory menus. However, to reach the accessory menus, the user may have to make a sequence of nearly twenty key presses while navigating through the menu system of the portable communication apparatus. This is clearly an annoyance when using an accessory that needs to be controlled through the portable communication apparatus' MMI. Thus, there is a need for a method and apparatus for enhancing accessory support for accessories connected to portable communication devices.

10

Summary of the Invention

It is an object of the invention to overcome the problems mentioned above with respect to the prior art, by providing a method and apparatus for enhancing accessory support for accessories connected to portable communication devices by allowing accessories to send icons and text information to the portable communication apparatus for display.

According to one embodiment of the invention, a portable communication apparatus primarily adapted for telecommunication is disclosed. The portable communication apparatus comprises, among other features, an accessory interface, a display and a controller. The accessory interface allows an external accessory device to be connected to the portable communication apparatus. The display has a visual presentation area. The controller is capable of presenting graphical information and text in the visual presentation area of the display to a user of the apparatus, wherein the visual presentation area of the display has at least one subarea reserved for presentation of accessory information received from the accessory device.

According to another embodiment of the invention, a method for providing enhanced accessory support in a portable communication apparatus primarily adapted for

35

telecommunication is disclosed. An external accessory device is attached to the portable communication apparatus having a display with a visual presentation area. Accessory information is sent from the external accessory device to the portable communication apparatus and the received accessory information is displayed in a subarea of the display.

Brief Description of the Drawings

10 The following detailed description, given by way of example and not intended to limit the present invention solely thereto, will best be appreciated in conjunction with the accompanying drawings, wherein like reference numerals denote like elements and parts, in which:

15 Figure 1 is schematic diagram illustrating a mobile telephone to which an external accessory device can be connected;

Figure 2 is a block diagram of the mobile telephone and accessory device architecture according to one embodiment of the invention;

Figure 3 is a flow chart illustrating how an accessory device uploads icons to a portable communication apparatus for display according to one embodiment of the invention;

25 Figure 4 is a flow chart illustrating how an accessory device can make an animation on the display of a portable communication apparatus according to one embodiment of the invention;

30 Figure 5 is a flow chart illustrating how an accessory can use previously uploaded icons in accessory menus and dialogs displayed on a portable communication apparatus according to one embodiment of the invention;

Figure 6 is a flow chart illustrating how an accessory can send text information to be displayed on the

display of a portable communication apparatus according to one embodiment of the invention; and

Figure 7 is a flow chart illustrating how an accessory adds menus and input dialogs to a portable communication apparatus according to one embodiment of the invention.

Detailed Description

With reference now to the figures wherein like or similar elements are designated with identical reference numerals, there are block diagrams and flowcharts depicting the invention. The purpose of these diagrams is to illustrate the features of the invention and the basic principles of operation of embodiments thereof. These diagrams are not necessarily intended to schematically represent particular modules of circuitry or any particular data or control paths. It should also be emphasised that the terms "comprises" and "comprising" when used in this specification is taken to specify the presence of stated features, integers, steps or components but does not preclude the presence or addition of one or more other features, integers, steps, components or groups thereof.

Figure 1 illustrates a portable communication apparatus such as a mobile telephone 10 to which an external accessory device 22 can be connected. The term portable communication apparatus includes portable radio communication equipment. The term portable radio communication equipment, which herein after is referred to as a mobile radio terminal includes but is not limited to all equipment such as mobile telephones, pagers, communicators, i.e., electronic organizers, smartphones or the like. The external accessory device can be a variety of electrical devices including but not limited to music players, such as MP3-players and radios, computers, facsimile machines, external charging units for the mobile

telephone, etc. The mobile telephone 10 has, among other features, a display 12 and a keypad 14. According to one embodiment of the invention, at least one of the keys on the keypad 14 is an option key 15 which does not have a fixed functionality but can be used to bring up a list of options that are relevant to the particular operation of the mobile telephone at a specific time. In addition, the mobile telephone 10 has at least one accessory interface or connector 16 for connecting the mobile telephone 10 to the external accessory device 22. In this example, the mobile telephone 10 is connected to the external accessory device 22 via a connection 18, such as a removable cable or wire by connecting the accessory interface 16 to an interface or connector 20 on the external accessory device. It will be understood that the mobile telephone 10 can be connected to a plurality of external accessory devices through various wired and wireless connections which use for example radio and infrared signalling but the invention is not limited thereto.

Figure 2 illustrates the architecture of some of the elements of the mobile telephone 10 and the external accessory device 22. Elements that have been depicted in the previous figure are identified by the same reference numerals. System and telephone functionality is under the control of a logic and control block 36. The logic and control block 36 comprises a microprocessor or equivalent and associated memory and logic circuitry for controlling the use and operation of the mobile telephone 10. A conventional radio receiver 32 and a radio transmitter 34 communicate interactively with a speaker 46, a microphone 33 and an antenna 35 in a conventional voice operating mode. The logic and control block 36 responds to entries from the keypad 14 through a keypad interface 44 to establish an operational mode and to administer its performance. The display 12 is activated and controlled,

through a display driver 42, in response to signals received from the keypad interface 44 and the logic and control block 36. Under this control, the display 12 will display characters that correspond to key entries from the keypad 14, data signals received by the receiver 32, text, images or icons sent to the display by the logic and control block 36. Key entry signals are input into the logic and control block 36, which outputs appropriate signals for driving the display 12. The display can be subdivided into different subareas of display such as subarea 54. Each subarea of the display can be reserved for different purposes. For example, the subarea 54 may be reserved for displaying text, images and icons sent from external accessory devices, but the invention is not limited thereto. Furthermore, the display need not be subdivided into different subareas, i.e the text, images and icons can be displayed anywhere on the display.

The external accessory device 22 comprises among other features a logic and control block 50, a memory 52 and the interface 20. System functionality of the external accessory device 22 is under the control of the logic and control block 50. The logic and control block 50 comprises a microprocessor or equivalent and associated memory and logic circuitry for controlling the use and operation of the external accessory device 22. As will be discussed in greater detail below, the logic and control block 50 can send accessory information such as icons, images, sound and text information to the mobile telephone 10 through the interface 20 and the connection 18. The logic and control block 36 of telephone processes the accessory information and then causes either icons, images or text messages sent from the external accessory device to be displayed in a subarea 54 of the display 12 or sound signals to be reproduced by the speaker 46.

As many accessories are defined after the portable communication apparatus functionality has already been fixed, it is not possible for the accessory to rely on support that is preinstalled in the portable communication apparatus such as a mobile telephone. If the accessory
5 wants to display an icon on the display of the mobile telephone, the accessory has to provide the mobile telephone with the icon. This could, for example, be performed with an AT command, where a bitmap for the icon
10 is one of the parameters of the AT command. As a response to the AT command, the mobile telephone will return a Unicode value whereby the icon may be referenced. As will be described below, the icons can be used in at least two ways, they can be added to the standby screen to give an
15 indication of the accessory status or they can be used as fonts in the accessory menus to render the menus less language dependent.

Figure 3 is a flow chart illustrating how an external accessory 22 device uploads two icons to a portable
20 communication apparatus such as the mobile telephone 10 and then adds the icons to a standby screen using a Unicode value returned to the accessory by the mobile telephone 10. In step 300, the accessory 22 is connected to the mobile telephone 10 as described above. The accessory 22 then
25 uploads the first icon (icon A) to the mobile telephone 10 using a first AT command in step 302. As mentioned above, the AT command may include a bitmap of the icon A. The mobile telephone 10 then sends a first Unicode value of icon A to the accessory 22 in step 304. The accessory 22
30 then uploads the second icon (icon B) to the mobile telephone 10 using a first AT command which includes a bitmap of the icon B in step 306. The mobile telephone 10 sends a second Unicode value of icon B to the accessory 22 in step 308. When the accessory wants to display, for
35 example, icon A, the accessory 22 sends an AT command which

includes, among other things, the first Unicode that was assigned to icon A in step 310. When the mobile telephone receives the Unicode for icon A, the mobile telephone 10 adds icon A to its predefined place in the standby screen and icon A is displayed in step 312. When the accessory 22 wants to remove icon A from the standby screen, the accessory 22 sends an AT command to the mobile telephone instructing the mobile telephone to remove icon A from the standby screen in step 314. This process can continue until the accessory 22 is disconnected from the mobile telephone 10. When the accessory 22 is disconnected from the mobile telephone 10, the icons for the accessory 22 are removed from the memory of the mobile telephone in step 316, but the invention is not limited thereto.

15 An icon previously uploaded and stored in the mobile telephone 10 can be added to the standby screen as an indication of the accessory status. As mentioned above, the icon is selected by referring to the Unicode value returned by the mobile telephone 10 when the icon was added to the memory of the mobile telephone 10. As will be explained below with reference to Figure 4, a simple animation can be achieved by adding several icons to the mobile telephone memory and then displaying them in an alternating sequence. In this example, icons A and B have already been uploaded to the mobile telephone 10 from the accessory device 22. In step 400, the accessory device 22 sends an AT command to the mobile telephone 10 with the Unicode of icon A requesting that icon A be displayed. The mobile telephone then adds icon A to its predefined place in the standby screen in step 402. The accessory device 22 then sends an AT command to the mobile telephone 10 with the Unicode for icon B requesting that icon B be displayed in step 404. The mobile telephone then displays icon B at its predefined place in the standby screen in step 406. The accessory by continuing to request that icons A and B be displayed in

this alternating fashion (as in steps 408 and 412) can cause icons A and B to be alternatingly displayed (as in steps 410 and 414) thereby creating an animation effect. The accessory can also request that one of the icons, for example, be removed from the display by sending an AT command to the mobile telephone in step 416, wherein the icon is removed from the standby screen in step 418. This process can continue until the accessory 22 is disconnected from the mobile telephone 10. When the accessory 22 is disconnected from the mobile telephone 10, the icons for the accessory 22 are removed from the memory of the mobile telephone in step 420, but the invention is not limited thereto.

The accessory menus and dialogs may not always be available in the language of the user. This problem becomes less severe if it is possible to use international icons (symbols) in the menus. As the icons stored in the mobile telephone memory can be referenced using a Unicode value, it is possible to include icons in an accessory menu. Figure 5 illustrates how an accessory can use previously uploaded icons in accessory menus and dialogs. In this example, the accessory has already uploaded several icons to the mobile telephone using , for example, the method disclosed in Figure 3. As noted in step 500, the accessory 22 has been attached to the mobile telephone 10 and a persistent menu item for the accessory 22 has been added to the mobile telephone's menu system. When the user selects the persistent menu item for the accessory 22, the mobile telephone 10 sends an AT command to the accessory 22 indicating that the persistent menu item has been selected in step 502. The accessory 22 then sends the mobile telephone a submenu with icons using an AT command which refers to the Unicodes of the icons in the submenu in step 504. The mobile telephone then displays the accessory submenu with the icons in the display 12. If the user

selects the accessory submenu, the mobile telephone 10 sends an AT command to the accessory 22 indicating that the user has selected the accessory submenu in step 506. The accessory then sends an AT command to the mobile telephone 10 and input dialog which includes icons by referring to their unicode values in step 508. The mobile telephone 10 then displays the input dialog with icons on the display 22. This process can continue until the accessory 22 is disconnected from the mobile telephone 10. When the accessory 22 is disconnected from the mobile telephone 10, the icons for the accessory 22 are removed from the memory of the mobile telephone in step 510, but the invention is not limited thereto.

According to another embodiment of the invention, accessory status text can be displayed in a stand-by screen. The accessory can use an AT command to display a text message in a standby screen. The accessory sends the text to the mobile telephone and the text is shown in the standby screen and could, for example, replace the operator's name while the accessory is connected. If the text does not fit in the screen, it can be wrapped or scrolled horizontally. Figure 6 illustrates how an accessory can send a text message, for example a status text message, to a portable communication apparatus for display in the standby screen. In step 600, the accessory 22 is connected to the mobile telephone 10. The accessory 22 then adds a persistent menu item to the mobile telephone 10 in step 602. The accessory then sends an AT command to the mobile telephone 10 to add a row of status text in the standby screen of the mobile telephone in step 604. The status text is then displayed in the standby screen of the display 12. As noted above, if the text doesn't fit in the screen it can be wrapped or scrolled horizontally. When the accessory changes its state and wants to update the status text to reflect the change in status, the accessory 22

sends a new AT command to add a row new text which reflects the change in status in step 606. The mobile telephone 10 then displays the new text in the standby screen. When the accessory 22 changes its state and wants to remove the status text from the standby screen, the accessory sends an empty AT command to the mobile telephone in step 608. The mobile telephone 10 then removes the status text from the standby screen. This process can continue until the accessory 22 is disconnected from the mobile telephone 10. When the accessory 22 is disconnected from the mobile telephone 10, the text for the accessory is removed from the display 12.

According to another embodiment of the invention, accessory menus can be made available by using an option key. As noted above, a user may have to press a sequence of nearly twenty keys while navigating through known menu structures of mobile telephones to reach the accessory menus. This is clearly an annoyance when using an accessory that needs to be controlled through the mobile telephone's man/machine interface. To facilitate the manipulation of the accessory menus, the menus should be accessible not only from their fixed place within the menu system but also from an adaptive key, a so-called option key 15. The option key 15 does not have a fixed functionality but rather brings up a list of options that are relevant to the present state of the mobile telephone. For example, when at least one accessory is attached to the mobile telephone, the option key 15 can be used to display a list of accessory menus.

Figure 7 illustrates how an accessory adds menus and input dialogs to a portable communication apparatus in response to user actions. When the accessory 22 is connected to the mobile telephone 10 in step 700, the accessory sends a persistent menu item to the mobile telephone 10 in step 702. When the user activates the

accessory menu via the mobile telephones menu system or via the option key, the mobile telephone 10 displays the accessory menu on the display 12 in step 704. If the user chooses the accessory menu, the users choice is sent back to the accessory in step 706. The accessory then sends a submenu back to the mobile telephone using an AT command in step 708. The accessory submenu is then displayed on display 12. If the user chooses the accessory submenu, the users choice is sent to the accessory in step 710. The accessory 22 can then add input dialog to the display by sending an AT command to the mobile telephone with the input dialog in step 712. The input dialog is then displayed on the display 12 for user input in step 713. This process can continue until the user leaves the accessory menus or the accessory 22 is disconnected from the mobile telephone 10 in step 714.

Although several embodiments of the method and apparatus of the invention has been illustrated in the accompanying drawings and described in the foregoing detailed description, it will be understood that the invention is not limited to the embodiments disclosed, but is capable of numerous rearrangements, modifications and substitutions without departing from the spirit of the invention as set forth and defined by the following claims.

CLAIMS

1. A portable communication apparatus (10) primarily adapted for telecommunication, comprising:
- 5 an accessory interface (16) through which an external accessory device (22) may be connected to the portable communication apparatus;
- a display (12) having a visual presentation area; and
- 10 a controller (36) capable of presenting graphical information and text in the visual presentation area of the display (12) to a user of the apparatus (10),
- characterised** in that the visual presentation area of the display has at least one subarea (54) for presentation of accessory information received from the accessory device
- 15 (22).
2. The portable communication apparatus according to claim 1, wherein the accessory information comprises at least one icon for presentation in the subarea (54) of the
- 20 display (12).
3. The portable communication apparatus according to claim 1 or 2, wherein the accessory information comprises text information for presentation in the subarea (54) of
- 25 the display (12).
4. The portable communication apparatus according to any of the preceding claims, wherein the accessory information comprises at least one image for presentation
- 30 in the subarea (54) of the display.
5. The portable communication apparatus according to any of the preceding claims, wherein the accessory information comprises sound signals to be reproduced by a
- 35 speaker (46) in the apparatus (10).

6. The portable communication apparatus according to any of the preceding claims, further comprising:

a keypad (14) on the portable communication apparatus (10), wherein the user can use the keypad (14) to control
5 the external accessory device.

7. The portable communication apparatus according to any of the preceding claims, wherein the portable communication apparatus (10) is a mobile telephone.

10

8. The portable communication apparatus according to any of the preceding claims 2-7, wherein the external accessory device (22) sends an AT command with at least one icon bit map as a part of the command parameters to the
15 portable communication apparatus (10).

9. The portable communication apparatus according to any of the preceding claims 2-8, wherein the external accessory device (22) sends an AT command to the portable communication apparatus to display the at least one icon which was previously stored in the portable communication apparatus (10,38), wherein the portable communication apparatus associates the at least one icon with the external accessory device (22).

25

10. The portable communication apparatus according to any of the preceding claims 3-9, wherein the external accessory device (22) sends to the portable communication apparatus (10) an AT command comprising the text
30 information for presentation in the subarea (54) of the display (12).

11. The portable communication apparatus according to any of the preceding claims, further comprising:

an option key (15) with dynamic functionality, wherein the functionality of the option key depends on the state of the portable communication apparatus (10).

5 12. The portable communication apparatus according to claim 11, wherein an accessory menu sent from the external accessory device (22) is displayed when the option key (15) is selected.

10 13. A method for providing enhanced accessory support in a portable communication apparatus (10) primarily adapted for telecommunication, wherein it is

detected when an external accessory device (22) is attached to the portable communication apparatus (10) (300),
15 said portable communication apparatus (10) having a display (12) with a visual presentation area; **characterised** by the further steps of:

 sending accessory information from the external accessory device (22) to the portable communication
20 apparatus (10) (302); and

 displaying the received accessory information in At least one subarea (54) of the display (12) (312).

25 14. The method according to claim 13, wherein the accessory information comprises at least one icon for presentation in the subarea (54).

30 15. The method according to claim 13 or 14, wherein the accessory information comprises text information for presentation in the subarea (54) of the display (12).

35 16. The method according to any of the claims 13-15, wherein the accessory information comprises at least one image for presentation in the subarea (54) of the display (12).

17. The method according to any of the claims 13-16, wherein the accessory information comprises sound signals to be reproduced by a speaker (46) in the apparatus (10).

5

18. The method according to any of the claims 13-17, further comprising the step of:

controlling the external accessory device (22) using a keypad (14) on the portable communication apparatus (10).

10

19. The method according to any of the claims 13-18, wherein the portable communication apparatus (10) is a mobile telephone.

15

20. The method according to any of the claims 14-19, wherein the external accessory device (22) sends an AT command with at least one icon bit map as a part of the command parameters to the portable electronic apparatus (10).

20

21. The method according to any of the claims 14-20, wherein the external accessory device (22) sends an AT command to the portable communication apparatus to display the at least one icon which was previously stored in the portable communication apparatus (10,38), wherein the portable communication apparatus (10) associates the at least one icon with the external accessory device (22).

25

22. The method according to any of the claims 15-21, wherein the external accessory device (22) sends to the portable communication apparatus an AT command comprising the text information for presentation in the subarea (54) of the display (12).

30

23. The method according to any of the claims 14-22, further comprising the step of:

removing the at least one icon from the subarea (54) of the display (12) when the external accessory device (22) is disconnected from the portable communication apparatus (10).

24. The method according to any of the claims 15-23, further comprising the step of:

removing the text information from the subarea (54) of the display (12) when the external accessory device (22) is disconnected from the portable communication apparatus (10).

25. The method according to any of the claims 14-22, further comprising the step of:

creating a simple animation in the subarea (54) of the display (12) by alternating the display (12) of a plurality of icons.

26. The method according to any of the claims 13-25, wherein an accessory menu sent from the external accessory device (22) is displayed when an option key (15) is selected.

27. A portable communication apparatus (10) primarily adapted for telecommunication, comprising:

an accessory interface (16) through which an external accessory device (22) may be connected to the portable communication apparatus;

a speaker (46); and

a controller (36) capable of controlling the speaker (46) for reproducing sound,

characterised in that the apparatus has a memory (38) for storage of sound information received from the

accessory device (22) for reproduction by said speaker (46).

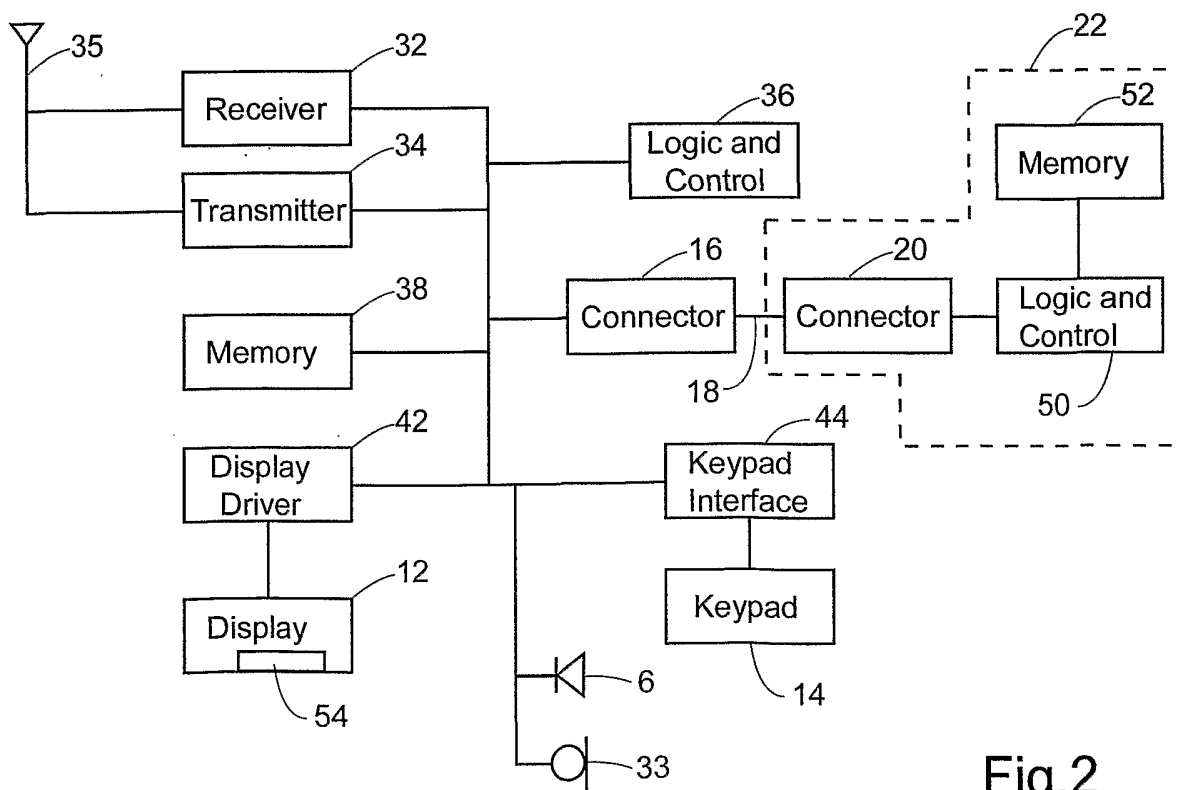
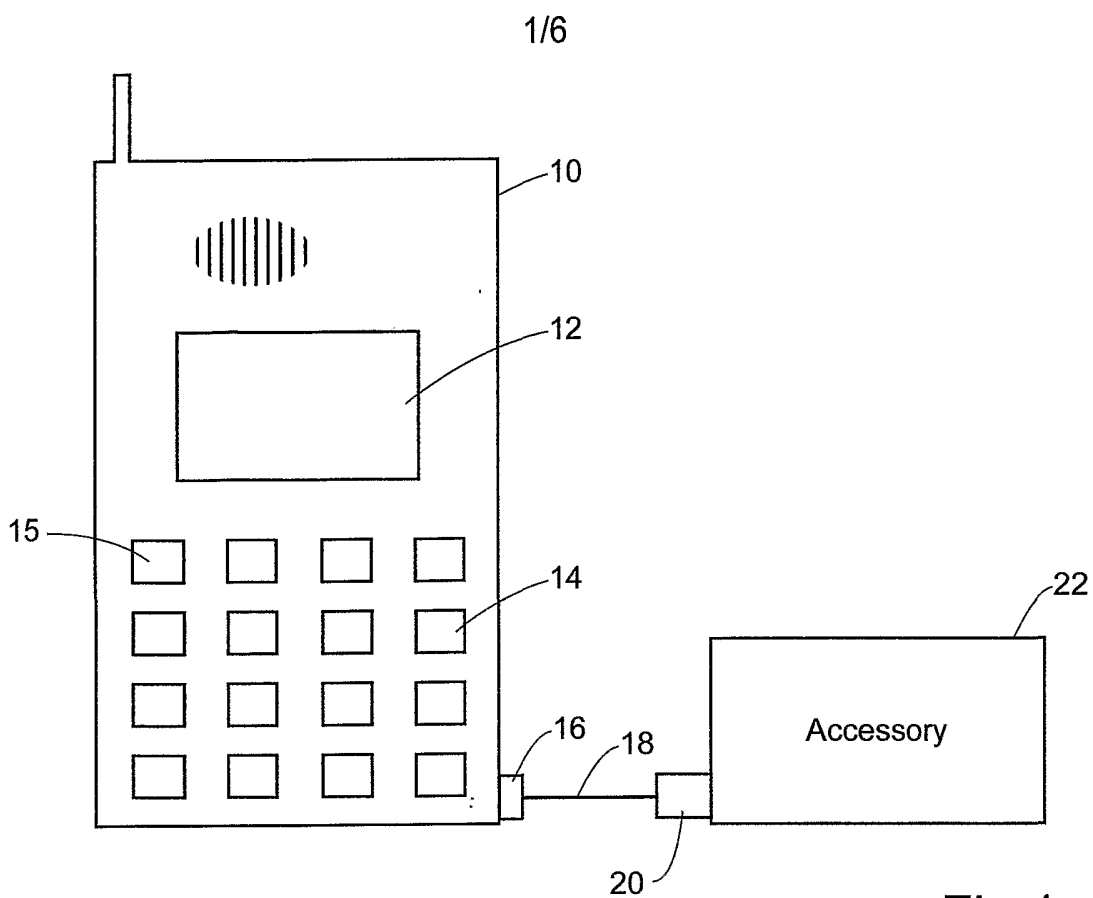

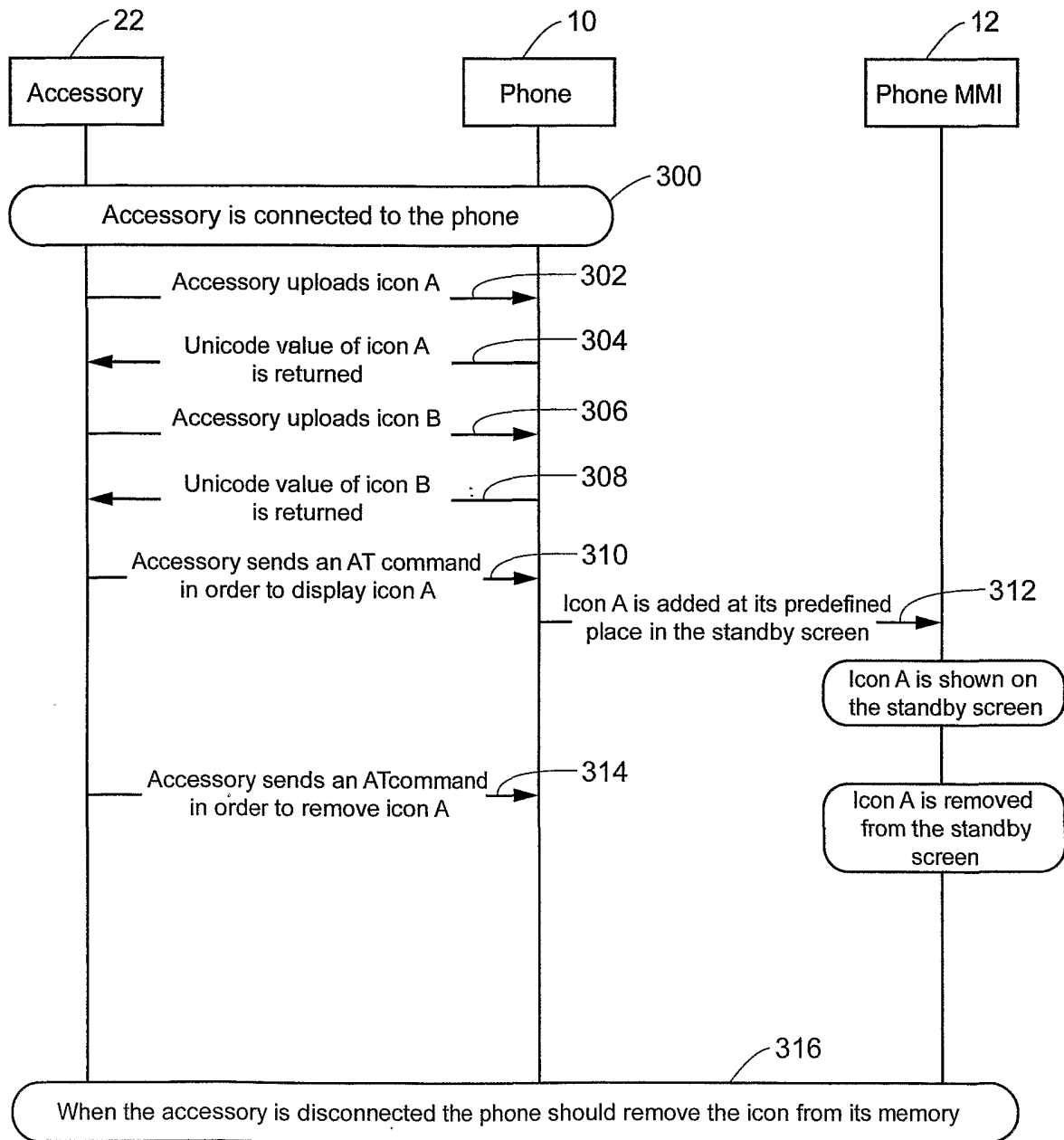

Fig.3

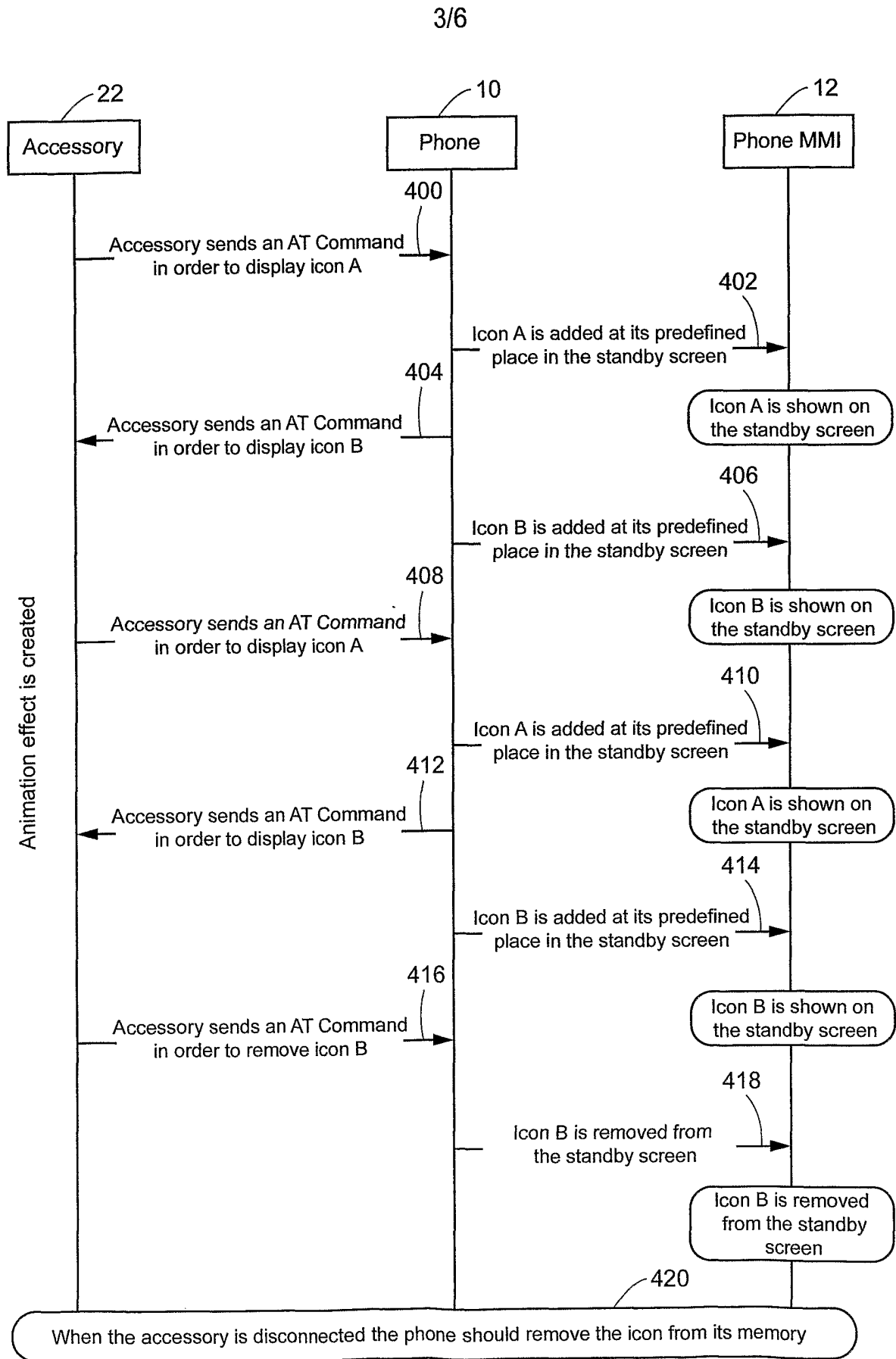

Fig.4

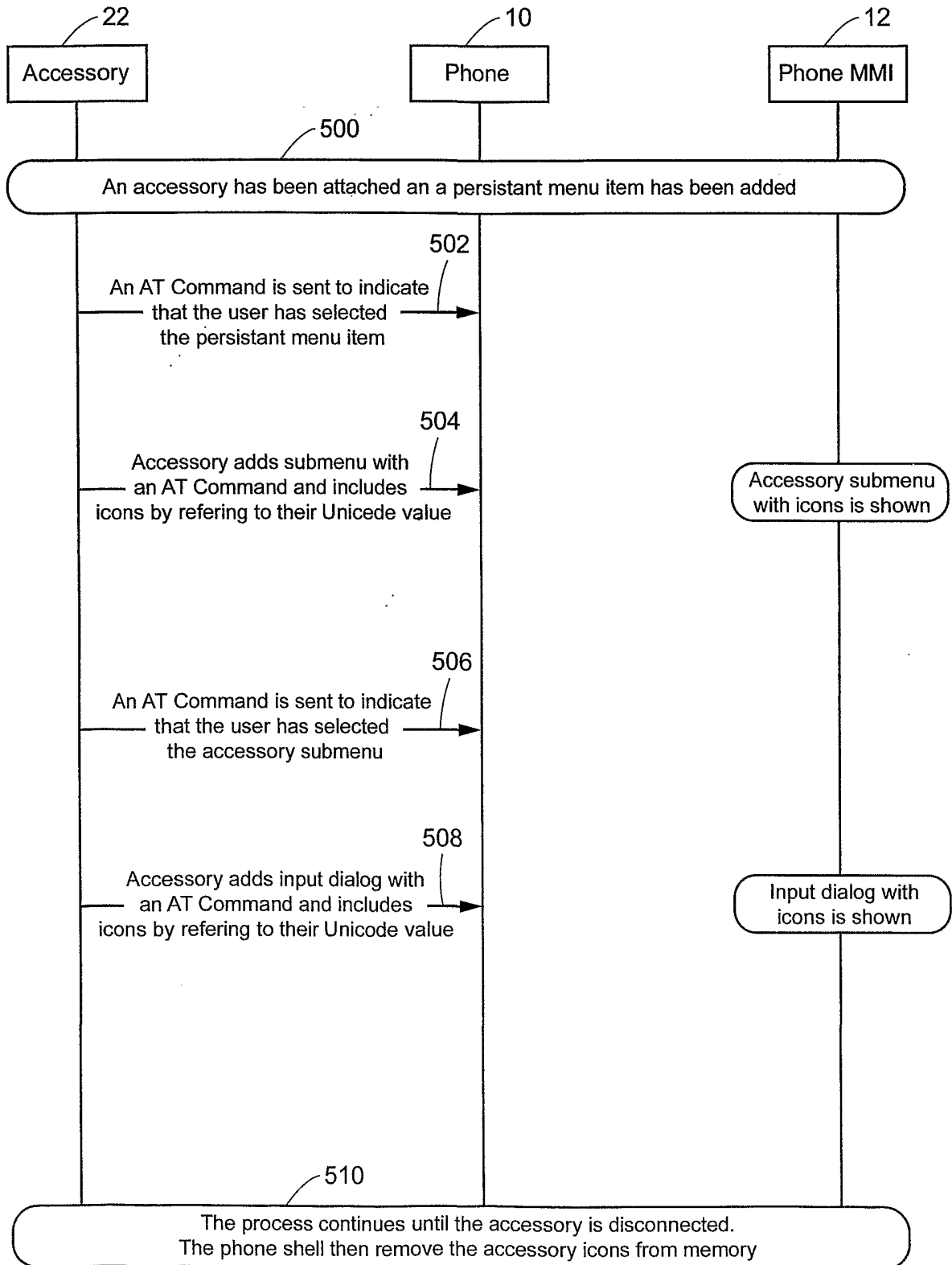

Fig.5

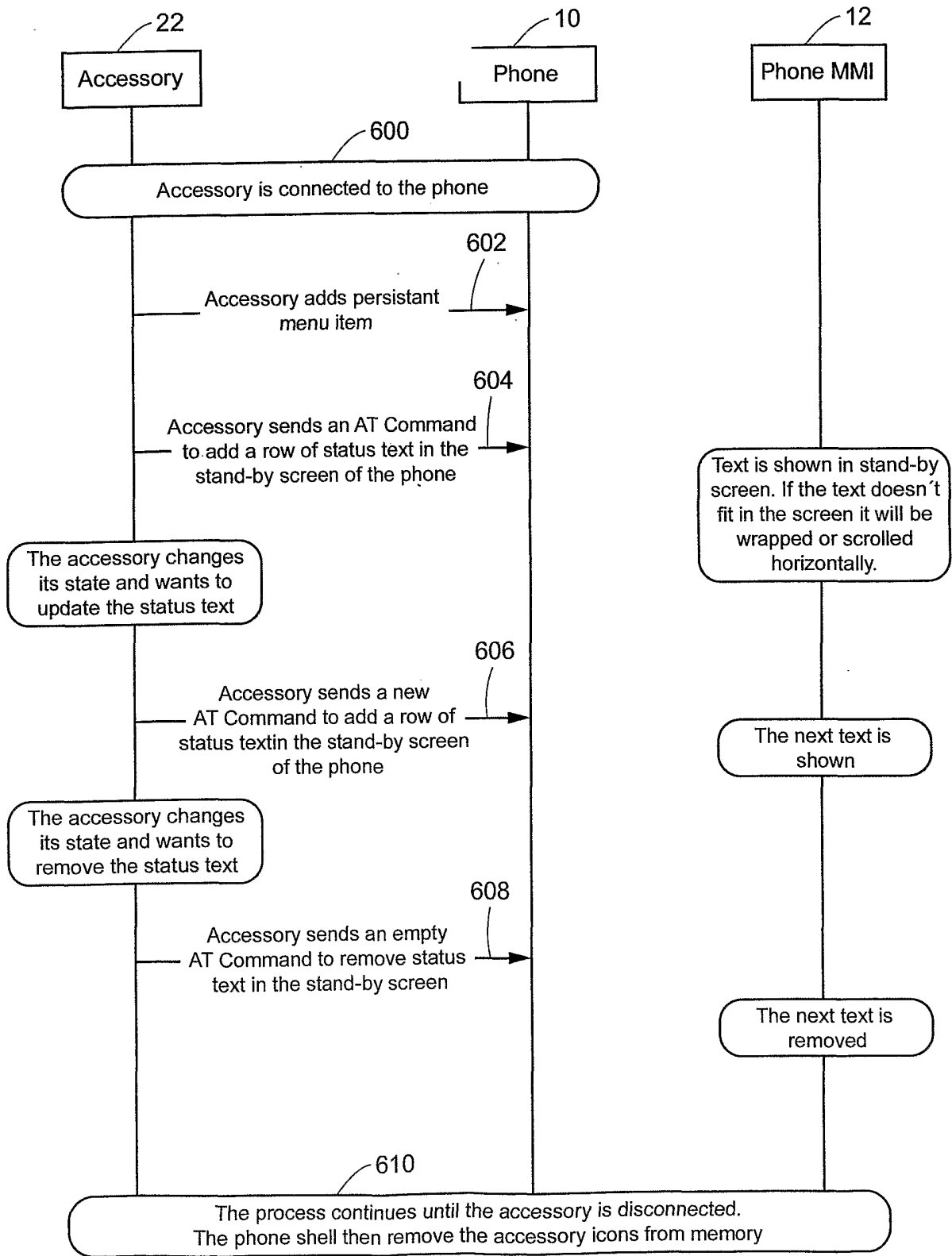

Fig.6

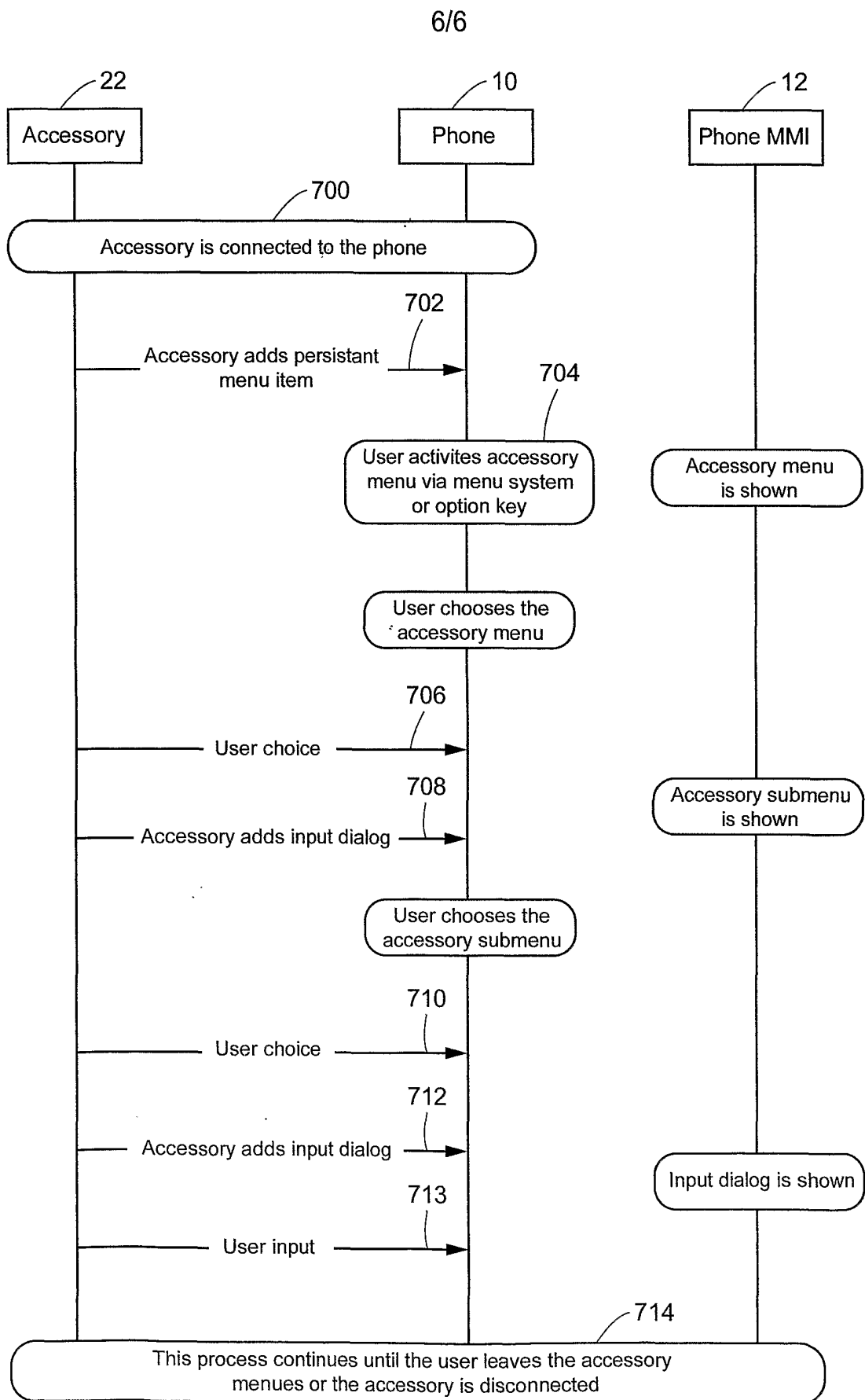

Fig.7