

(19) World Intellectual Property Organization
International Bureau



(43) International Publication Date
17 January 2008 (17.01.2008)

PCT

(10) International Publication Number
WO 2008/007949 A2

(51) International Patent Classification:
F24F 7/02 (2006.01)

(21) International Application Number:

PCT/NL2007/000173

(22) International Filing Date: 6 July 2007 (06.07.2007)

(25) Filing Language: Dutch

(26) Publication Language: English

(30) Priority Data:

1032137 9 July 2006 (09.07.2006) NL

1032350 21 August 2006 (21.08.2006) NL

1033419 19 February 2007 (19.02.2007) NL

(71) Applicant (for all designated States except US): **BOOTS-
MAN HOLDING BV** [NL/NL]; Opaallaan 14, NL-2132
XT Hoofddorp (NL).

(72) Inventor; and

(75) Inventor/Applicant (for US only): **BOOTSMAN, Gerrit**
[NL/NL]; Opaallaan 14, NL-2132 XT Hoofddorp (NL).

(74) Agent: **ASSENDELFT, Jacobus, Hendrikus, Wilhel-
mus**; Keukenhofdreef 20, NL-2161 AZ Lisse (NL).

(81) Designated States (unless otherwise indicated, for every kind of national protection available): AE, AG, AL, AM, AT, AU, AZ, BA, BB, BG, BH, BR, BW, BY, BZ, CA, CH, CN, CO, CR, CU, CZ, DE, DK, DM, DO, DZ, EC, EE, EG, ES, FI, GB, GD, GE, GH, GM, GT, HN, HR, HU, ID, IL, IN, IS, JP, KE, KG, KM, KN, KP, KR, KZ, LA, LC, LK, LR, LS, LT, LU, LY, MA, MD, ME, MG, MK, MN, MW, MX, MY, MZ, NA, NG, NI, NO, NZ, OM, PG, PH, PL, PT, RO, RS, RU, SC, SD, SE, SG, SK, SL, SM, SV, SY, TJ, TM, TN, TR, TT, TZ, UA, UG, US, UZ, VC, VN, ZA, ZM, ZW.

(84) Designated States (unless otherwise indicated, for every kind of regional protection available): ARIPO (BW, GH, GM, KE, LS, MW, MZ, NA, SD, SL, SZ, TZ, UG, ZM, ZW), Eurasian (AM, AZ, BY, KG, KZ, MD, RU, TJ, TM), European (AT, BE, BG, CH, CY, CZ, DE, DK, EE, ES, FI, FR, GB, GR, HU, IE, IS, IT, LT, LU, LV, MC, MT, NL, PL, PT, RO, SE, SI, SK, TR), OAPI (BF, BJ, CF, CG, CI, CM, GA, GN, GQ, GW, ML, MR, NE, SN, TD, TG).

Published:

— without international search report and to be republished upon receipt of that report

For two-letter codes and other abbreviations, refer to the "Guidance Notes on Codes and Abbreviations" appearing at the beginning of each regular issue of the PCT Gazette.

(54) Title: VENTILATION SYSTEM

(57) Abstract: The invention relates to a ventilation system as emergency provision at fire. Two cylinders with parallel piston rods are used. The one cylinder is designed for typical operation and can be single or double acting and is connected to a source of pressurised air. The other cylinder is sealed and acts as gas spring en is kept pre loaded by a fuse. The gas spring can be replaced by a mechanical spring.



WO 2008/007949 A2

Ventilation system

The inventor has designed a novel emergency system for the pneumatic drive of features in buildings to provide vertical or horizontal ventilation during a fire. Such provisions are e.g. provided with windows, hatches, doors or louvres (commonly named "panel") in the typically flat roof of a building. By opening these during a fire in the building, a vertical or horizontal air flow is allowed, preventing collapse of the roof.

10 With the present systems use is made of a relatively small bottle filled and sealed with liquid pressurised gas, e.g. CO₂, N₂ or He, which is connected to a valve with fuse. If the fuse activates, the valve connects the bottle through conduits with the pneumatic drive cylinder of the ventilation system. The
15 contents of the bottle have at room temperature a pressure of more than 50 bars, or even 80 bars or more.

Separated from this emergency system the panel can be provided with a pneumatic cylinder operating at a relatively low pressure of not more than 10 bar, with which the panel during
20 typical use of the building can be remotely operated to be positioned in a ventilation position.

The object of the inventor is a system with one or more of the following advantages: simpler, cheaper, more reliable, lighter weight, longer life, easier to inspect/maintain, more
25 compact, safer, less complex structure, quicker to install, lower pressures, less parts.

A first proposal of the inventor is therefore, to make use for the emergency system of a gas spring or mechanical spring in combination with a release mechanism, such as a fuse, which
30 keeps the spring pre tensioned. If during a fire the fuse melts, e.g. at 70 degrees Celsius, it releases the spring, which then releases its elastic energy, with which the panel is opened.

Preferably the gas spring is of a type with at both sides of the within the cylinder slidable piston a from the surroundings
35 sealed, by the piston limited space, which spaces are mutually and preferably continuously fluidly connected and contain a pressurised gas with a relative to the surrounding higher pressure, e.g. at least 1 or 2 or 5 bars higher, wherein a piston rod is mounted to the piston and extends through one of said spaces

externally from the gas spring, wherein the from the gas spring projecting end is adapted for driving an object. The spaces together contain a fixed quantity of pressurised gas.

The combination of the spring and fuse and a preferably
5 linear actuator, such as a pneumatic cylinder, is preferred. This actuator provides the panel operation during typical use of the building. The actuator is preferably a pneumatic cylinder of single acting type, preferably with at the one side of the piston a by the piston bound, relative to the surrounding sealed and
10 with pressurised gas filled space. This space is preferably located at the side of the piston to which the piston rod is mounted. The pneumatic gas can be replaced by a mechanical spring external or integrated within the cylinder.

Preferably the emergency system has an element adapted to
15 be driven by the spring, while it has a free displacability relative to the spring. E.g. the element is designed such that the spring gives it a pushing force, while the element can make a free movement relative to the spring along the track, or part of it, which the pushing force follows or extends parallel to
20 it. Thus the distance between the spring and the element can vary at the time the spring activates during e.g. a fire.

This element can be part of a between spring and actuator acting coupling means (in the drawing element 28), designed to allow the spring to make use of its driving or movement energy
25 to open/close the panel. Preferably the coupling means is de-activated as long as the fuse is not molten.

The invention comprises one or more of the following (each of it provides, independently from or in combination with one or more of the others, the subject matter of this invention):
30 a single acting pneumatic cylinder with a with a fixed quantity pressurised gas filled piston space, applicable for many fields; the pressurised space mounting to or integrating with the pneumatic cylinder; the pneumatic space supplying with the compressor of the building, or with a spaced reservoir; making
35 use of an element, such as a spring, to store energy in it in connection with opening or closing a panel of the ventilation system, e.g. wherein the spring is kept pre loaded by a pressurised

cylinder; keeping the panel closed with the aid of pressurised gas; a design such that if the supply of pressurised gas ceases, the driving of the panel activates; using a double acting or single acting cylinder to drive the panel; simultaneously loading both
5 sides of the piston of the cylinder with pressurised gas, preferably wherein the one side is supplied through a pressure reducing element; supplying and/or operating the system with a pressure of the pressurised gas of no more than 10 or 15 bar.

If in this specification reference is made to a cylinder,
10 as a rule a cylinder/piston combination is meant.

The invention is defined in the claims.

The invention is now illustrated non-limiting by way of the enclosed drawing, showing in:

Fig. 1 a side view of a ventilation structure;

15 Fig. 2 a side view of an air cylinder;

Fig. 3 a side view of a driving system;

Fig. 4 a gas spring with fuse;

Fig. 5a and 5b the combination of fig. 4 with air cylinder;

Fig. 6-8 an application of the assembly of fig. 5;

20 Fig. 1 illustrates in top view the rectangular frame to be fixedly mounted in the opening in the roof of a building. Two panels 1 are over approximately 90 degrees pivoting mounted to the frame. They are in the drawing shown in the completely opened, ventilating, position. Opening and closing of the panels is driven
25 by for each panel 1 an individual actuator assembly, in this example a pneumatic cylinder (linear actuator) 2 which are indicated in the closed position of the panel with dashed lines and in the open position of the panel with full lines.

Fig. 2 shows a cylinder 2 within which a piston 3 is slidable
30 to retract/extend a piston rod 4 to move the panel. The cylinder is longitudinally separated by a separating element 5, which is pressurised gas tight provided at a fixed location, into a piston space 6 and an emergency reservoir 7 for pressurised gas. The piston 3 is a slidable, fluid tight separating element within
35 the piston space 6. The cylinder contains at both sides a connection nipple 8 and a seal 9. The piston rod projects in a slidable manner pressurised gas tight through the one seal. The

separation element 5 is provided with a pressure reducing element through which the reservoir is in fluid connection with the piston space 6 at the one side of the piston. If both connection nipples are connected to a common pressurised gas source (e.g. through plastic conduits), within the reservoir 7 and at the other side (the piston rod side) of the piston substantially the same system pressure of, e.g., 6 bars prevails. At the one, from the reservoir supplied, side of the piston 3 a lower pressure is active of, e.g., 2 bars due to the action of the pressure reducing valve. Thus the piston rod is kept in the illustrated, retracted position. As soon as the pressure at the piston rod side of the piston drops below 2 bars, the piston will displace and extend the piston rod. Pressure drop below 2 bars is e.g. a result of venting the cylinder at the side of the piston rod, e.g. by triggering of a fuse that is present in the pressurised gas conduit connected to the relevant connection nipple 8, or due to failure of the relevant pressurised gas conduit due to e.g. melting during a fire. The reservoir can via a convenient sealant, such as one way valve (e.g. located in the supply conduit) be isolated to be able to supply pressurised gas through the pressure reducing valve to the piston space, or in case of rupture of the relevant pressurised gas conduit.

An alternative to the embodiment of fig. 2 is e.g. wherein one or more of the emergency reservoir 7, the connection conduit from the reservoir to the piston space 6 and the reducing valve is physically separated from the cylinder.

The emergency reservoir is preferably in close proximity of the cylinder located (e.g. at substantially equal level).

In case of a not in the drawing illustrated embodiment, possibly based on an in de drawing illustrated embodiment, the with pressurised fluid filled cylinder keeps a pull or push spring pre loaded through transmission means connected to both. As soon as the cylinder is vented, the spring can relax, while the piston rod is pushed in/extends, and thus provides driving power to open/close the panel. With this example a pressurised gas reservoir as emergency supply for the cylinder is unnecessary. The spring is e.g. via a lever mechanism mounted to the panel, such that the push or pull force of the spring is converted into

the required torque. The spring could be replaced by a source containing a different potential energy, possibly functioning as linear actuator, e.g. a (not to a supply connected) cylinder or a weight. This embodiment is particularly applicable to open 5 louvres or such panels which typically over an angle smaller than 90 degrees are pivoted between the completely closed and completely opened position.

Fig. 3 shows a ventilation system wherein the cylinder 2 is drivingly coupled with a flexible pulling means 11 (e.g. a 10 tension stiff cable) with which a with the panel 1 coupled transmission is driven. With that also use is made of a push or pull spring 12 as balancing element. In the embodiment the cable is wrapped around a drum 13 such that it can be rotated around its body axis 14. The cable is also endless and at the other end 15 of the loop wrapped around a return wheel 15. The drum drives an around the same axis 14 pivoting lever 16, at the free end of which an arm 17 is pivotably mounted, at the free end of which the panel 1 is mounted at a distance to its pivot point. The balancing element 12 is mounted to the same or a different lever 20 (16 or 17). With the aid of the lever 16 and the arm 17 it is possible to pivot the panel 1 over more than 90 degrees while the pivot axis 19 of the panel extends at a distance parallel to the axis 14. The spring 12 is preferably mounted to a preferably around the axis 14 pivoting lever 18, such that in the maximum 25 opened position of the panel the force coming from the spring 12 extends substantially parallel to the lever 18, respectively crosses the axis 14 (i.e. exerts a minimum torque). With the elements 17 and 16 an over centre system can e.g. be provided, such that in the maximum opened position of the panel 1 the elements 30 16 and 17 mutually make an angle of more than 180 degrees while in the closed position they mutually make an angle smaller than 180 degrees.

The system of fig. 3 offers a compact and low loaded structure and offers the possibility of a substantial larger stroke compared 35 to e.g. a crank system to convert the linear movement of the piston rod into a pivot movement to drive the the panel opening lever.

The cylinder 2 of fig. 3 can be of the type as disclosed

here, preferably double acting, or be a variant based on it, possibly combined with a spring, e.g. as disclosed here, and a fuse keeping the spring pre loaded.

The gas spring 21 shown in fig. 4 comprises a cylinder in which a piston is reciprocating housed. A to the outside of the cylinder extending piston rod is connected to the piston. At both sides of the piston the cylinders delimits a hermetically from the surrounding sealed chamber, which are continuously in mutual fluid connection through a passage in the cylinder. The chambers are filled with pressurised gas, such as nitrogen, with a pressure higher than the ambient pressure or atmospheric pressure. Due to the passage through the piston, the pressure is always the same in both chambers. Thus, the same pressure acts onto both sides of the piston. At the side of the piston to which the piston rod is mounted, said pressure however acts onto a smaller piston surface compared to the other side of the piston due to the surface at the piston taken by the piston rod. This difference between piston surfaces in combination with the higher than ambient pressure within both chambers, yields a permanently the piston rod extending pre-load of which the rate is substantially constant and thus independent from the position of the piston or the amount of extension of the piston rod. The amount of said pre-load is a function of the diameter of the piston and the piston rod and of the gas pressure to which the piston is exposed and the ambient pressure. The movement behaviour of the piston and piston rod is a function of the rate of the pre-loading and the speed with which the pressurised gas can flow from the one to the other chamber through the passage in the piston.

The piston rod of this gas spring is kept by a fuse 23 in the retracted position, against the pre-load. The fuse is provided by two copper plates 24, 25 that overlap and in the overlapping area are mutually connected by a metal with low melting point. The one plate is fixed to the cylinder, the other to the piston rod.

Fig. 5 shows in side and top view the gas spring of fig. 4 combined with the single acting air cylinder 26, such that the piston rods of both extend mutually parallel. The air cylinder

contains an into it reciprocating piston, to the one side of which a piston rod 27 is mounted. The other end of the piston rod extends outside the cylinder. At both sides of the piston there is a by the piston delimited space within the cylinder. The space through 5 which the piston rod extends, is hermetically sealed from the ambient space and filled with a fixed quantity of pressurised gas. The other space has through a closable inlet and/or outlet opening a connection with a source of pressurised gas or the ambient atmosphere. By supplying through the inlet opening 10 pressurised gas to the one space, the piston rod is extended wherein the pressurised gas through which the piston rod extends, is compressed, pre loading the piston rod to the retracted position. By subsequently venting the one space through the outlet opening, the piston rod moves back while pressurised gas is ejected from 15 the one space and pressurised gas in the other space expands. In a different embodiment the function of the one and other space are changed, such that the one space is filled with a fixed quantity pressurised gas and the other space can be supplied/vented.

To the from the air cylinder projecting end of the piston 20 rod an arm 28 is mounted providing a free relative to the gas spring 21 displaceable element that in all extended positions of the piston rod projects into the track that is followed by the end of the piston rod 22 of the gas spring. Thus it is guaranteed that the air cylinder 26 can function independent from gas spring 25 21, while during emergency operation the driving energy of the gas spring can be transferred from the arm 28 to the panel 1.

The assembly of fig. 5 is in fig. 6-8 applied to a louvre system. As is known, louvres comprise typically a number of parallel, elongated, in the closed position with the longitudinal 30 edges mutually overlapping blades 1, each in a fixed location pivoting around a longitudinally extending (preferably central) body axis 29 and each with a longitudinal edge pivoting mounted spaced along a common, rigid and crosswise/perpendicular to the blades extending adjusting element. The air cylinder is via 35 pneumatic conduits controlled, e.g. from the switching box at street level to retract/extend its piston rod to with that open or close the ventilation (fig. 6/7).

The air cylinder is at its one end pivoting mounted to the building. The piston rod 27 of the air cylinder 26 is drivingly mounted to the panel.

During a fire (see fig. 8) the fuse collapses. The gas spring 5 21 can then relax and supply driving or moving energy, by extending the piston rod. Through the coupling means 28 this energy is transferred to the panel 1. The force to be supplied by the gas spring must in this case be large enough to overrule the force due to compression of the pressurised gas within the sealed space 10 of the air cylinder.

The illustrated example of fig. 6-8 makes use of a pull spring 31 to support the air cylinder 26 and gas spring 21 while opening the panel 1. Alternatively a different auxiliary drive can be used, e.g. a counter weight. Or such an auxiliary drive can be 15 absent. The invented emergency system can be applied to a different type fire ventilation.

In stead of a single acting air cylinder with a with a fixed quantity of pressurised gas filled piston space, a single or double acting type, of which both piston spaces are vented, can be used. 20 In stead of a fixed quantity pressurised gas in the one space of the single acting air cylinder, this space can be vented. Retracting of the piston rod during typical operation is then provided by a separate reset means, such as a spring, which can be mounted into the cylinder.

25 Tests have shown that the system according to fig. 6-8 can operate at a maximum pressure of 10 bar pressurised air to drive the air cylinder. Within the gas spring and the air cylinder the pressure can remain below 20 bars, for example e.g. 15 bar. The stroke of the piston is e.g. approximately 15 cm.

30 All specified or in de drawing illustrated features provide as such or in arbitrary combination the subject matter of this invention.

Independent invention: system with cylinder, piston space and reservoir, piston space and reservoir are connected to the 35 same source of pressurised gas, the reservoir is connected to the piston space through a pressure reducing connection (fig. 2).

CLAIMS

1. Device comprising a first linear actuator (26) for connection to a supply to provide driving capacity by the actuator
5 (26), and a second linear actuator (21) which is kept at a pre load by a releasing mechanism, such as a fuse (23), responding to a predetermined event, wherein the second linear actuator is/comprises preferably a gas spring or mechanical spring.
2. Device according to claim 1, wherein the first linear
10 actuator is a pneumatic cylinder of single or double acting type.
3. Device according to claim 2, wherein the cylinder contains a mechanical spring or fixed quantity of pressurised gas at the one side of the piston.
4. Device according to any of claims 1-3, comprising an element
15 (28) designed to be driven by the second actuator (21), while it has a capacity to move freely relative to the actuator, wherein preferably the element (28) is also, preferably permanently, coupled with the first actuator.
5. Device according to any of claims 1-4, wherein the first
20 and second actuator are designed to provide a mutual parallel operation.
6. Device according to any of claims 1-5, located in a building and drivingly coupled to a panel (1) to selectively sealing a ventilation opening.
- 25 7. Device according to any of claims 1-6, drivingly coupled to a flexible puling means (11) to, preferably through a linkage (16, 17), driving of a preferably pivoting mounted element (1) through a transmission (14) and possible provided with a balancing element (12). (fig. 3)
- 30 8. Device, possibly combined with any of claims 1-7, providing an emergency system comprising a gas spring or mechanical spring in combination with a releasing mechanism, such as a fuse, keeping the spring tensioned, and adapted to open a fire ventilation of a building with the energy released from the spring.
- 35 9. Linear actuator for use in the device of any of claims 1-8, comprising a single acting cylinder with a non-vented piston space or a within the piston space located mechanical spring.

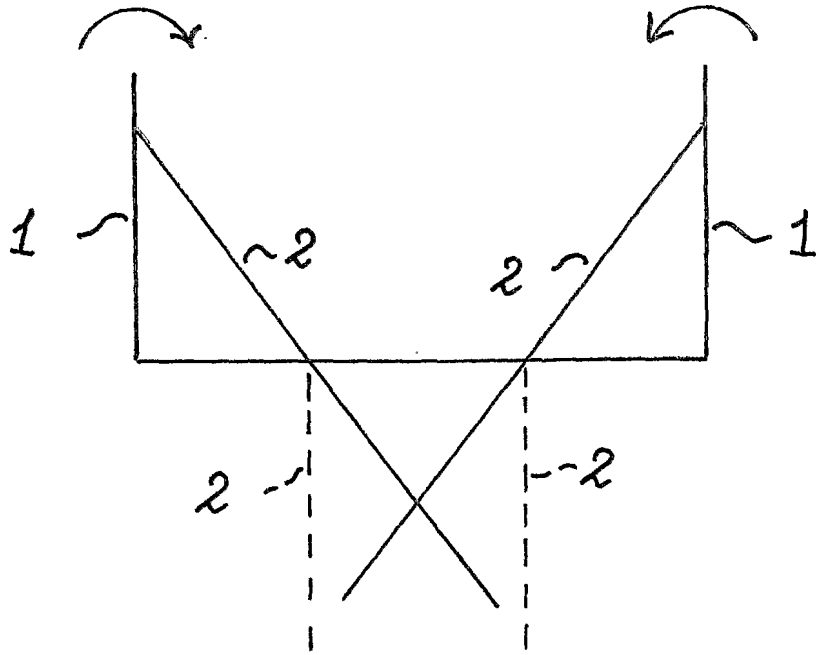

Fig.1

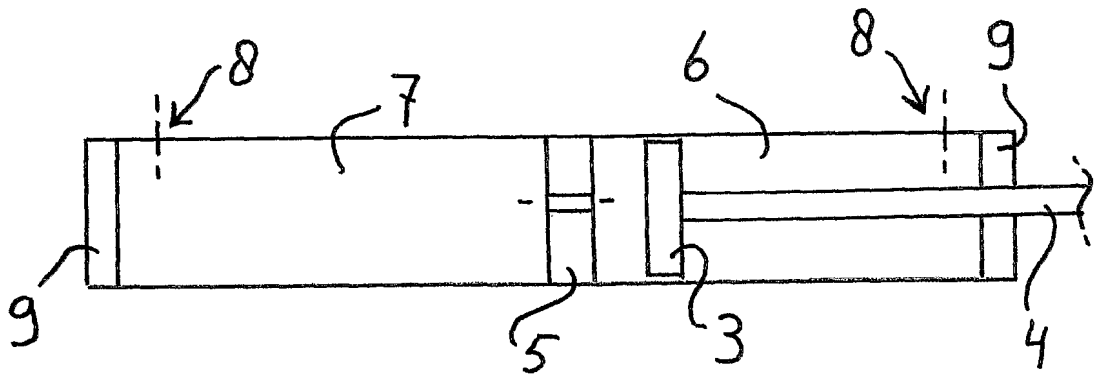

Fig.2

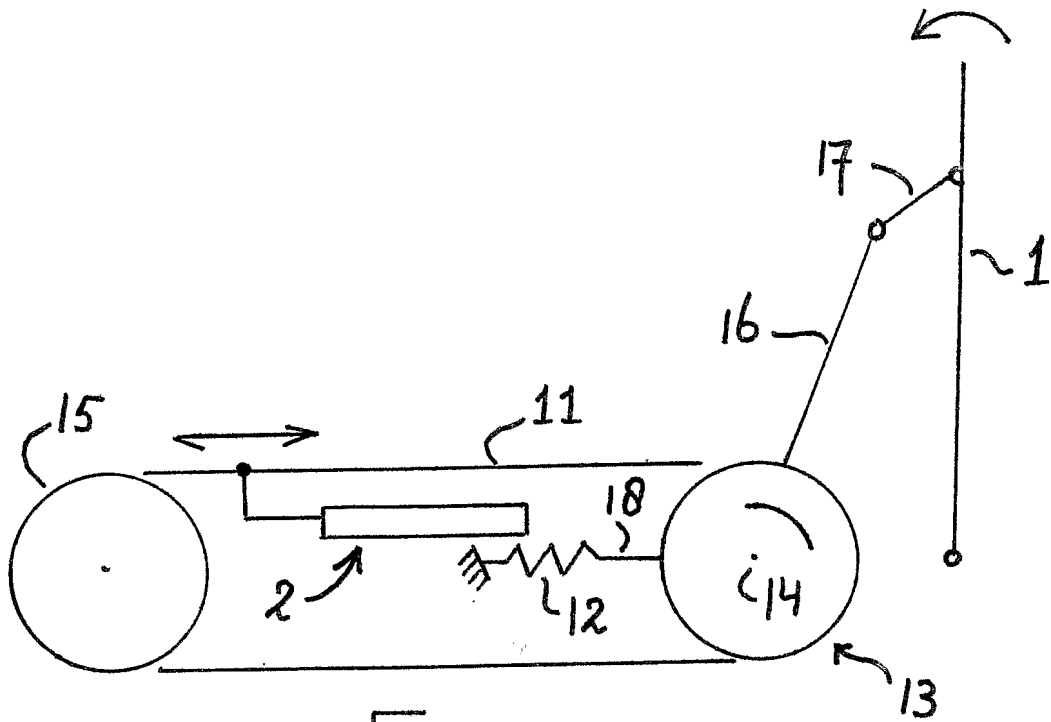

Fig. 3

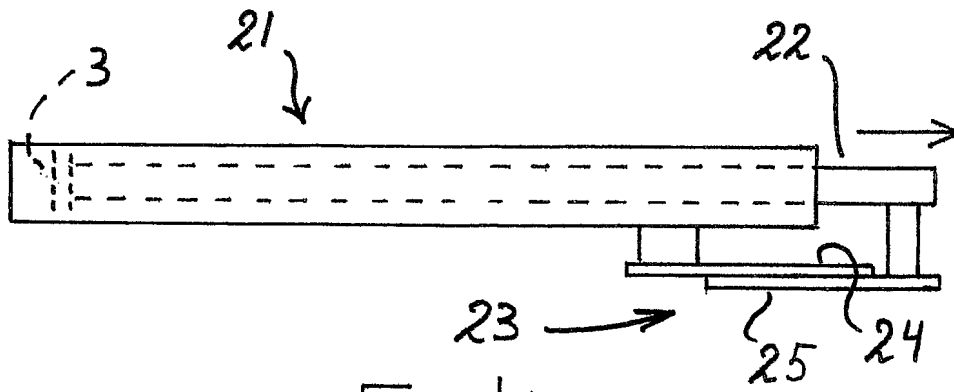

Fig. 4

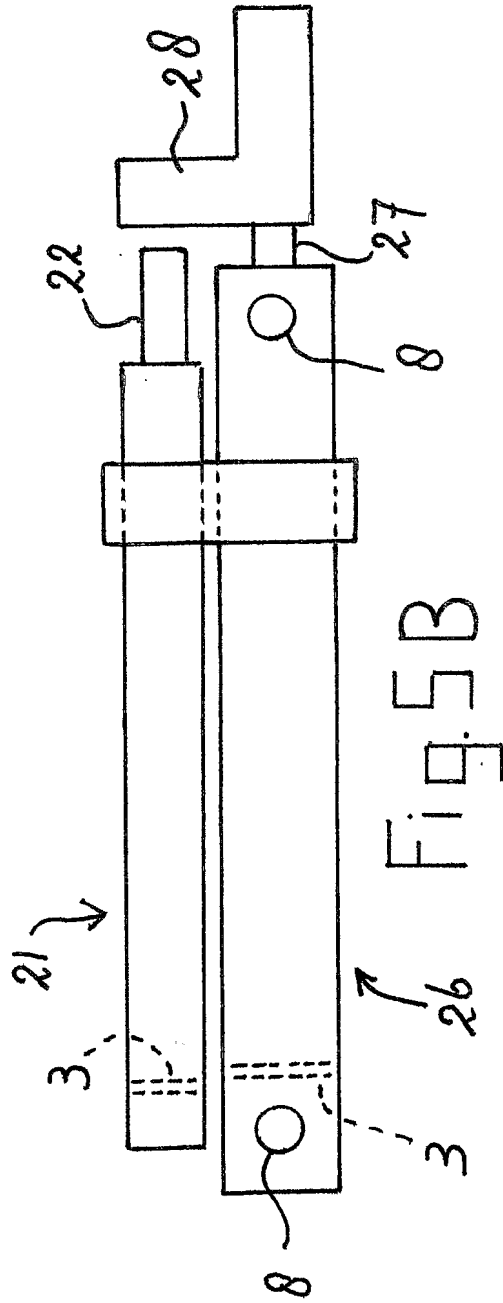
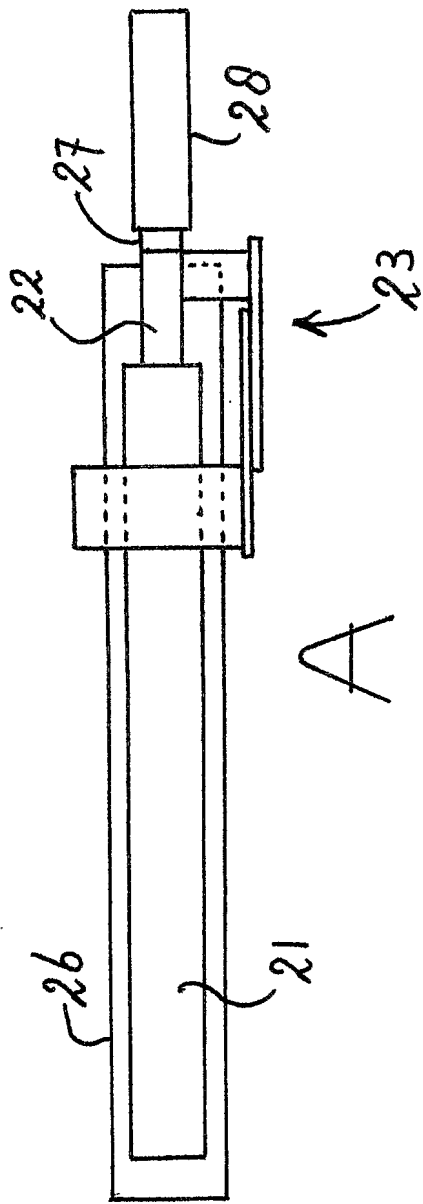

Fig. 5B

