

(19) World Intellectual Property Organization  
International Bureau



(43) International Publication Date  
21 December 2000 (21.12.2000)

PCT

(10) International Publication Number  
WO 00/77367 A2

(51) International Patent Classification<sup>7</sup>: F02B 75/00

(21) International Application Number: PCT/GB00/02248

(22) International Filing Date: 9 June 2000 (09.06.2000)

(25) Filing Language: English

(26) Publication Language: English

(30) Priority Data:  
9913702.8 11 June 1999 (11.06.1999) GB

(71) Applicant and

(72) Inventor: GALVIN, George, Frederic [GB/GB]; 9  
Christchurch Road, Sidcup, Kent DA15 7HG (GB).

(74) Agent: PRATT, David, Martin; David Pratt & Co., 7  
Parkhill Road, Sidcup, Kent DA15 7NW (GB).

(81) Designated States (*national*): AE, AL, AM, AT, AU, AZ,  
BA, BB, BG, BR, BY, CA, CH, CN, CR, CU, CZ, DE, DK,

DM, EE, ES, FI, GB, GD, GE, GH, GM, HR, HU, ID, IL,  
IN, IS, JP, KE, KG, KP, KR, KZ, LC, LK, LR, LS, LT, LU,  
LV, MA, MD, MG, MK, MN, MW, MX, NO, NZ, PL, PT,  
RO, RU, SD, SE, SG, SI, SK, SL, TJ, TM, TR, TT, TZ, UA,  
UG, US, UZ, VN, YU, ZA, ZW.

(84) Designated States (*regional*): ARIPO patent (GH, GM,  
KE, LS, MW, MZ, SD, SL, SZ, TZ, UG, ZW), Eurasian  
patent (AM, AZ, BY, KG, KZ, MD, RU, TJ, TM), European  
patent (AT, BE, CH, CY, DE, DK, ES, FI, FR, GB, GR, IE,  
IT, LU, MC, NL, PT, SE), OAPI patent (BF, BJ, CF, CG,  
CI, CM, GA, GN, GW, ML, MR, NE, SN, TD, TG).

Published:

— Without international search report and to be republished  
upon receipt of that report.

For two-letter codes and other abbreviations, refer to the "Guid-  
ance Notes on Codes and Abbreviations" appearing at the begin-  
ning of each regular issue of the PCT Gazette.

(54) Title: PISTON AND CONNECTING ROD ASSEMBLY

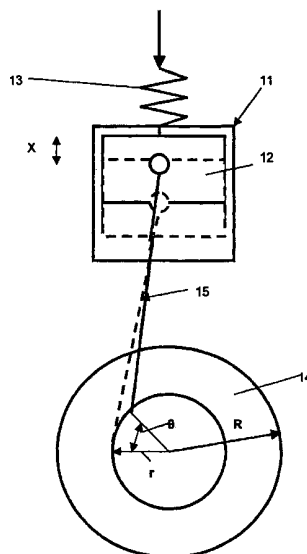

(57) Abstract: A piston and connecting rod assembly for an internal combustion engine comprises a piston (12), a connecting rod (15), and a spring (13). The connecting rod (15) has a first end operatively associated with the piston (12) for movement therewith, and a second end connectible to a rotary output shaft. The spring (13) acts between the piston (12) and the connecting rod (15) to bias the connecting rod away from the crown of the piston. The assembly is such that the energy stored in the spring (13) as it is compressed by the expanding gases resulting from combustion during an ignition stroke is substantially equal to the energy returned to the spring during the subsequent power stroke.



WO 00/77367 A2

### Piston and Connecting Rod Assembly

This invention relates to a piston and connecting rod assembly for an internal combustion engine.

A conventional internal combustion engine employs a crankshaft to  
5 convert the reciprocating motion of the piston(s) into output torque to propel a  
vehicle or act upon any other load. The crankshaft is inefficient in its ability to  
convert the power available from the fuel combustion into usable output torque.  
This is because combustion of the fuel/air mixture takes place a number of degrees  
before the top dead centre (TDC) position of the piston, dependent upon engine  
10 speed and load. The ignited fuel/air pressure forces cannot produce output torque  
when the piston is either before or at TDC as the connecting rod and the crank pin  
are producing reverse torque before TDC and are practically in a straight line at  
TDC so that there is no force component tangential to the crank circle. This results  
in most of the available energy being lost as heat. If ignition takes place too early,  
15 most of the pressure generated is wasted trying to stop the engine (as this pressure  
tries to force the piston in the opposite direction to which it is travelling during the  
compression stroke); and, if left too late, the pressure is reduced due to the  
increasing volume above the piston as it starts its descent for the power stroke. The  
optimum maximum pressure point varies from engine to engine, but is around 12°  
20 after TDC on average.

The specification of my co-pending GB patent application 9620227.0  
relates to a piston and connecting rod assembly for an internal combustion engine.  
The assembly comprises a piston, a connecting rod, and a spring, the connecting  
rod having a first end operatively associated with the piston for movement  
25 therewith, and a second end connectible to a rotary output shaft. The spring acts  
between the piston and the connecting rod to bias the connecting rod away from  
the crown of the piston. This assembly will be referred to throughout this  
specification as an energy storage piston.

In use, ignition is timed, by conventional timing means to take place at

-2-

a predetermined time before TDC, so that the expanding gases formed by the ignition combustion force the piston to descend rapidly within the cylinder during the power stroke. Prior to reaching TDC, however, the pressure in the cylinder will build up to a high value, and the piston is forced towards the crank pin, against the force of the spring. This compresses the spring, and increases the volume above the piston, causing a reduction in pressure and temperature in the cylinder. The lowered temperature reduces radiation losses and the heat lost to the cooling water and subsequently the exhaust, with the pressure being shared equally between the cylinder clearance volume and the spring. This energy stored in the spring is released when the piston has passed TDC, and leads to the production of output torque. This is achieved as the spring pressure is now combined with the cylinder pressure after TDC. A large proportion of this stored energy would otherwise have been lost as heat, owing to the fact that the fuel/air mixture must be ignited before TDC, which is a result of the requirement for the ignited fuel/air to reach maximum pressure by about 12° after TDC for optimum performance.

The assembly of GB patent application 96 20227.0 preferably uses a stack of disc springs as the spring which acts between the piston rod and the connecting rod. Disc springs are also known as Belleville washers or cone springs.

Disc springs are typically used in devices such as railway buffers, aircraft landing gear, die presses, etc., i.e. devices that operate relatively infrequently. They may be employed to absorb oscillating motion, but the frequencies they are subjected to, and the duration of those frequencies, are likely to be very low compared with their life cycle in an automobile piston.

A 2-stroke engine in a go-kart, for example, operates at up to 20,000 rpm which is 333 cycles per second. To operate at such frequencies in an energy storage piston, the disc springs used have to be built for extremely high endurance.

An average car travels, say 12,000 miles per year, at an average speed of 30 mph. This 30 mph equates to approximately 1,500 rpm. Over a year, this is

the equivalent of 36 million operations. Clearly, with this endurance requirement, the springs need to be of superior quality, and should be ideally labelled as 'precision springs'.

One of the problems with the present disc spring designs is that they are produced in two cross-section profiles, namely the rectangular section of Fig. 1, or the rectangular section having chamfered, diametrically-opposite bearing faces of Figs. 2 and 3.

Both of these sections lead to damaging stresses being set up at their abutting edges. In particular, as shown in Fig. 1, any constraining devices provided to keep the discs aligned, need some clearance to allow the springs to achieve the flat condition without fouling the alignment devices. The inevitable misalignment can cause deep striations in the abutting edges, and will lead to premature failure. The existing chamfered edge design of Figs. 2 and 3 provides contact surfaces for alignment when uncompressed, but introduces alignment problems as compression takes place and the contact surfaces depart from their initial parallel position (see Fig. 3).

The aim of the invention is to provide an improved assembly of this type.

According to a first aspect, the present invention provides a stack of disc springs for incorporation in a piston and connecting rod assembly to act between the piston rod and the connecting rod of said assembly, wherein the disc springs are so profiled that adjacent contacting surfaces of each pair of adjacent disc springs roll against one another as the stack of disc springs is compressed or decompressed.

Preferably, said contacting surfaces each have a generally part-circular profile. In particular, the outer peripheral surface of each disc spring has a semi-circular profile.

Advantageously, the disc springs are made of a titanium alloy such as titanium Timetal 15-3, and preferably they are subjected to ageing at a high temperature, followed by air cooling. At least the contacting surfaces, and

preferably the entire surfaces, of the springs are vibro-polished and shot peened, after ageing, to produce a fine, smooth, blemish-free finish.

A superior cross-sectional profile, which will greatly reduce localised stress points and friction between the springs, is shown in Fig. 4, which is a cross-section taken through a pair of adjacent disc springs constructed in accordance with the invention.

Fig. 5 shows the section of one of the springs 1, and Fig. 6 is a plan view of the spring of Fig. 5. In practice, the stack of disc springs is constituted by a number of disc springs, made of titanium Timetal 15-3. The number of springs used depends upon the application concerned. The springs 1 are aged at 482°C for 16 hours and then air cooled, at 496°C for 8 hours and then air cooled, or at any other suitable combination of time and temperature.

As shown, the disc springs 1 are formed with generally semi-circular profiles at their outer circumferential edges 1a, so that, in use, these edges roll against one another as the stack is compressed (and as the stack releases energy during decompression). The springs 1 are vibro polished and shot peened, after ageing, to produce a fine, smooth, blemish-free finish which is substantially free from surface striations. This results in their life cycle being extended by a factor of up to 10 times. The semi-circular abutting surfaces 1a allow the springs 1 to roll over each other, reducing friction, and allowing the points of contact in a spring stack to be normal to points of radius contact, thereby resisting the springs' tendency to lateral misalignment. This lateral misalignment, which is the case in a rectangular cross-section spring (caused by the points of contact not being normal), would cause corner damage, resulting in premature failure. This is not the case with the design of Fig. 4.

For disc springs of this type, the stresses within a spring for a given load can be calculated using the following parameters, namely the inner diameter, the outer diameter and the thickness. The equations (or tables) used for these calculations are based on the assumption that the springs have a rectangular

section. However, the springs of the present invention are of semi-circular section at their inner and outer diameters. Accordingly, in order to use these equations (tables) with semi-circular sectioned springs, the parameters used in the equations (tables) must be modified to take into account the modified disc shape. This modification is to increase the outer diameter by 42.4% of the disc thickness, and to decrease the inner diameter by 42.4% of the disc thickness. These 42.4% variations now measure the inner and outer diameters from the centres of mass of the semi-circles, that is to say between the inner and outer centroids.

According to a second aspect, the present invention provides a piston and connecting rod assembly for an internal combustion engine, the assembly comprising a piston, a connecting rod, and a spring, the connecting rod having a first end operatively associated with the piston for movement therewith, and a second end connectible to a rotary output shaft, the spring acting between the piston and the connecting rod to bias the connecting rod away from the crown of the piston, wherein the assembly is such that the energy stored in the spring as it is compressed by the expanding gases resulting from combustion during an ignition stroke is substantially equal to the energy returned to the spring during the subsequent power stroke.

In a preferred embodiment, the assembly further comprises a flywheel for storing energy produced at the rotary output shaft, and for returning part of this energy to the assembly during non-power strokes. As the piston "oscillates", that is to say as the cyclical movement of the piston due to the repeated compression and decompression of the spring (this cyclical movement being superimposed on the normal reciprocatory piston movement), this "oscillation" is transferred to the flywheel to superimpose a cyclical increase and decrease in its rate of angular rotation upon its "normal" angular rotation. Throughout this specification, the terms "piston oscillation" and "flywheel oscillation" should be construed accordingly.

As mentioned above, the energy storage piston contains a spring which,

after storing part of the combustion energy, releases this energy by transferring it to a flywheel, and hence to the output shaft.

This spring/mass arrangement has a resonant frequency at which it is most efficient. This resonance occurs when the energy stored in the spring substantially equals the energy returned to the spring from the flywheel. The  
5 energy stored in the spring is a function of the force applied to it and the distance through which it moves, whilst the energy stored in the flywheel is a function of the inertia of the flywheel and its angular rate of rotation.

In most mechanical arrangements of moving masses, there is a restoring  
10 force acting on the mass. This force could be wind, gravity, a spring or its own resilience. If a resonance is set up on the mass and is sustained, the amplitude of the movement of the mass could reach such proportions that damage occurs. Clearly, this is undesirable, and many systems containing such properties are also equipped with dampers. These are designed to reduce the tendency to “resonate”  
15 to acceptable proportions.

In the case of the energy storage spring, however, its maximum amplitude of oscillation is limited by the physical movement of the spring and the stroke of the piston, i.e. the crank throw, so no uncontrolled oscillation can occur. The spring/mass assembly, however, does have a frequency at which it is resonant;  
20 and, when this occurs at the same frequency as that dictated by the engine’s speed (rpm), then the engine will require a minimum input of fuel to sustain this oscillation. The inbuilt friction in the engine will exert damping on this frequency, which will have the effect of reducing its effectiveness at the resonant frequency, but will conversely extend the bandwidth of the response curve, thereby  
25 improving the engine’s performance over a wider range of engine speeds.

Further to the above, the inbuilt friction in the system (which results mainly from the need for the piston rings to seal tightly the high pressure in the combustion chamber) results in the springs being easily compressed during the period of combustion around TDC where the side forces on the piston (hence

-7-

friction on the walls) are a minimum. After TDC, the cylinder pressure rises to a maximum value at around  $12^\circ$  after TDC and then falls inversely to cylinder volume, so the side thrust on the walls after TDC will approximately follow the product of the sine of the angle of rotation and the cylinder pressure. This will have the effect of delaying the spring energy release, such that the crank arm has reached a more advantageous position to produce output torque, ie around  $80^\circ$  after TDC.

Although in mechanical engineering terms, there are many applications of spring/mass/damper arrangements such as a car suspension system, there are few applications of a spring/rotary mass (inertia)/damper arrangement.

A spring and connected mass with no internal friction, air friction or any other application of friction, if subjected to an impulse displacement, will cause the spring/mass arrangement to oscillate, gravity being the constant force on the mass, and the tension in the spring being equal and opposite to this force.

Figure 7 shows schematically a flywheel/crankshaft/piston assembly incorporating the energy storage piston referred to above. This assembly includes a cylinder 11, a piston 12, an energy storage spring 13 (which is constituted by a stack of disc springs of the type shown in Figure 4 - but here is illustrated schematically), a flywheel 14, and a connecting rod 15. The condition that enables resonance to be exploited in the energy storage piston engine is that the spring 13 has a high stiffness, and that the engine has, by design, a rotating mass (inertia) which enables a resonant condition to exist. The spring 13 is chosen in dependence upon the maximum peak pressure in the cylinder 11 which, on ignition, is generally in the region of 50 bar (see Figure 8 - which is a pressure/crank angle curve for a typical internal combustion engine) for a normal compression ratio engine, and increases with an increasing compression ratio.

The spring 13 can only store approximately half this pressure, as the pressure above the piston crown decreases proportionally to the compression of the spring. Therefore, for a given piston diameter, displacement and normal

-8-

compression ratio, and a peak pressure of say 50 bar, the mean height of the clearance volume, and the resultant force on the spring 13 achieved in the compression chamber, can be calculated.

Under resonant conditions, the piston 12 moves with respect to the connecting rod 15, the gudgeon pin and the big end (neither of which are shown), thereby compressing and decompressing the spring over an "oscillation" having a linear amplitude  $x$ , whose value is given by :-

$$x = \theta \cdot r \quad \text{where } \theta \text{ is the angular amplitude of the flywheel "oscillation", and } r \text{ is the crank throw.}$$

10 The energy  $E$  stored in a small oscillation is the product of the average force supplied and the distance moved, i.e.

$$E = m \cdot \omega^2 \cdot x^2 / 2$$

where  $\omega$  is the frequency of the oscillation, and  $m$  is the oscillating mass.

15 The energy  $E_f$  transferred to the flywheel 14 is in the form of an oscillation of amplitude  $\theta$ , with the flywheel having a moment of inertia  $I$  such that:-

$$E_f = I \omega^2 \cdot \theta^2 / 2$$

The energy  $E_s$  stored in the spring 13 at maximum compression is:-

$$E_s = k \cdot x^2 / 2 \quad \text{where } k \text{ is the spring constant.}$$

20 Substituting  $x = \theta \cdot r$  then:-

$$E_s = k \cdot \theta^2 \cdot r^2 / 2$$

Equating spring energy  $E_s$  with flywheel energy  $E_f$ , then:-

$$k \cdot \theta^2 \cdot r^2 / 2 = I \omega^2 \cdot \theta^2 / 2$$

$$\therefore \omega = \sqrt{(k \cdot r^2 / I)}$$

25  $\therefore \omega = \sqrt{(k \cdot r^2 / m \cdot R^2)}$  as  $I = m \cdot R^2$

where  $R$  is the radius of gyration of the flywheel.

Thus, if the flywheel 14 has a mass  $m$  of say 2 kg distributed on the outer edge portion, and a radius  $R$  of gyration of say 0.07 m, then the resonant frequency  $f$  is:-

-9-

$$f = [ 1 / 2\pi \cdot \sqrt{( k / m ) \cdot r / R ]$$

if  $k = 10^6$  N/m,  $r = 24.4$  mm, and  $R = 70$  mm (these values being taken from a practical example):-

$$\begin{aligned} \text{then the rpm at resonance} &= 60 [ 1 / 2\pi \cdot \sqrt{( 10^6 / 2 ) \cdot 0.0244 / 0.07} ] \\ &= 2354 \text{ rpm} \end{aligned}$$

5

From the above example, it can be seen that, by suitable choice of flywheel mass and radius, the system's resonance can be used to advantage, in that it will assist the rotation of the flywheel and the crankshaft over a band of frequencies (rpm) which is dictated by the amount of friction in the system as a whole, over and above the improvement which results from the spring storing energy.

10

Thus, the resonant frequency of 2354 rpm lies substantially centrally within the rpm band (1500 to 3200 rpm) at which an automobile internal combustion engine normally runs. Although the maximum efficiency of the arrangement occurs at the resonant frequency, the amount of friction in the system ensures that, over the rpm predetermined band, the efficiency can be close to the maximum. Consequently, by varying the parameters  $k$ ,  $m$ ,  $r$  and  $R$ , the resonant frequency can be predetermined. Moreover, as mentioned above, the friction inherently present in the system ensures that the resonant bandwidth can be extended over a useful range.

15

20

It will be appreciated that the calculation of resonant frequency given above is based upon a simplified theory for unforced, small amplitude simple harmonic oscillations. In practice, the oscillations concerned are not simple harmonic, are forced, and may not be of small amplitude. Nevertheless, the simple theory does enable an approximate estimate of resonant frequency to be calculated. Once this approximate value is obtained, a more accurate value can be obtained empirically.

25

In a modified form of the engine shown in Figure 7, a typical spring constant is calculated to be  $1300 \times 10^3$  N/m. This example of a modified engine

is as would be used with a motorcycle. The spring constant is decided on engine displacement criteria, but the rotating mass of the flywheel 14 is partially decided by design and application, so there is some degree of flexibility in the ability to increase the inertia (a minimum calculated inertia is required to maintain the engine rotation). Ideally, in a motorcycle, the design should enable resonance to take place at around 3000 rpm.

Figure 8 shows a typical pressure curve in an internal combustion engine. This pressure is synchronised with the flywheel/crankshaft rotation in a 2-stroke engine, but operates every other cycle in a 4-stroke engine.

In this engine arrangement, the spring 13 is there primarily to store energy that would otherwise be wasted as heat when the crankshaft is in a disadvantageous position to produce output torque (that is to say before TDC and for a considerable angle after TDC). It is this energy that, when released, not only produces output energy to the load, but transfers some of this energy into the flywheel 14 to maintain rotation. It is this energy oscillating between the spring 13 and the flywheel 14 that does not have to be replaced by energy from the fuel.

The spring/mass/friction arrangement shown in Figure 9 is primarily an oscillatory mechanism superimposed on a rotational frequency, that is to say the engine's rpm. Clearly, as the oscillatory resonant frequency coincides with the engine rpm, then this is advantageous to the engine's performance.

In a system with a rotating flywheel and a conventional piston, the movement of the flywheel mass will always lag the applied force by an angle dependent upon the system's load, losses and friction. When the spring 13 is included, however, the angle will lead at low rpm, be at zero degrees at resonance, before returning to lagging above the resonant speed. So, in this application, the movement of the piston crown can be synchronised with the input pressure, and is then able to release this energy in synchronism with the engine rotation.

A standard engine without the energy storage spring can be represented as shown in Figure 9. A typical consumption figure for a single cylinder engine

-11-

might be say 1.23 Kg/hour. Then, if we assume an rpm of 3000, at 1.23 Kg/hour, one stroke consumes  $1.23/(3000 \times 60) = 6.83 \times 10^{-6}$  Kg of fuel. For a 4-stroke engine, the consumption is  $4 \times 6.83 \times 10^{-6}$  Kg, and the energy of a stroke is the consumption  $\times 45 \times 10^6$  Joules, that is to say  $27.33 \times 10^{-6} \times 45 \times 10^6 = 1230$  Joules.

5 Now to calculate the energy stored in the flywheel 14, let :

$$\text{the angular rate } \omega = 100\pi \text{ rads/sec (3000 rpm)}$$

The inertia I of the flywheel 14 is  $m \times R^2$  (mass  $\times$  radius of gyration squared). If we assume a mass  $m$  of 2 Kg and a radius of gyration R of  $61 \times 10^{-3}$ m, then:

$$\begin{aligned} \text{the flywheel energy } E &= \frac{1}{2} I \omega^2 \\ 10 \quad &= \frac{1}{2} \times m \times R^2 \times \omega^2 \\ &= \frac{1}{2} \times 2 \times (61 \times 10^{-3})^2 \times (100\pi)^2 \\ &= 374.4 \text{ Joules} \end{aligned}$$

Referring to Fig 10 (which illustrates the energy distribution of the standard engine of Figure 9), the energy input is 1230 Joules, and the energy in the flywheel, that is to say the load, is 347.4 Joules. Therefore, the energy lost to friction and heat is  $(1230 - 374.4)/1230 = 69.5\%$ , and so the output is 30.5%.

A standard engine with the energy storage spring can be represented as shown in Figure 11. If we assume now that 30.4% (that is to say 374.4 Joules) of energy is still required at the output, the aim is to establish the input required to maintain that same level of output when using the energy storage piston.

Taking the optimum condition at resonance, the engine speed (rpm) and the energy output to the load should be the same as the previous example, that is to say 3000 rpm and 374.4 Joules.

$$\text{At resonance } \omega = \sqrt{(k/m)} \times r/R$$

25 Where the spring constant  $k$  is  $1300 \times 10^3$  Nm (as mentioned above), the flywheel mass  $m$  is 2 Kg, the crank throw  $r$  is  $24 \times 10^{-3}$  m, and the radius of gyration R is  $61 \times 10^{-3}$  m, then as  $\omega = 2\pi f$

$$\begin{aligned} \text{the rpm is } &1/2\pi \sqrt{(1300 \times 10^3 / 2)} \times (24 \times 10^{-3}) / (61 \times 10^{-3}) \times 60 \\ &= 3000 \end{aligned}$$

So, at resonance in this arrangement, the rpm of 3000 is the same as the rpm in the example without the energy storage piston, so a comparison can be made.

Now, in a resonant condition, the energy stored in the flywheel 14 is returned to the spring 13 every other (for a 4-stroke cycle) revolution and vice versa, so the energy consumed in the engine will be to heat and friction as the energies in the spring and flywheel are antiphase and cancel, but provide the energy for the load. As the 374.4 Joules load energy has to be maintained for comparison purposes, then 69.5% is shared between friction and heat. The energy distribution is now as shown in Figure 12, from which it will be seen that the reduction in input required to produce the same energy output as the engine without the energy storage spring is:

$$(1230 - 853)/1230\% = 30.6\%$$

and the reduction in heat energy is:

$$(59.5 - 46.1)/59.5\% = 22.5\%$$

This is reflected in a saving of fuel of 30%

It will be apparent that modifications could be made to the assembly described above. Thus, the number of disc springs in the stack is not critical, being dependent upon the required engine characteristics and the material from which they are made. For example, in a modified form of engine, three or four disc springs can be used.

**Claims**

1. A piston and connecting rod assembly for an internal combustion engine, the assembly comprising a piston, a connecting rod, and a spring, the  
5 connecting rod having a first end operatively associated with the piston for movement therewith, and a second end connectible to a rotary output shaft, the spring acting between the piston and the connecting rod to bias the connecting rod away from the crown of the piston, wherein the assembly is such that the energy stored in the spring as it is compressed by the expanding gases resulting from  
10 combustion during an ignition stroke is substantially equal to the energy returned to the spring during the subsequent power stroke.
2. An assembly as claimed in claim 1, further comprising a flywheel for storing energy produced at the rotary output shaft, and for returning part of this  
15 energy to the assembly during non-power strokes.
3. An assembly as claimed in claim 2, wherein the arrangement is such that the cyclical movement of the piston due to the repeated compression and decompression of the spring (this cyclical movement being superimposed on the  
20 normal reciprocatory piston movement), is transferred to the flywheel to superimpose a cyclical increase and decrease in its rate of angular rotation upon its normal angular rotation.
4. An assembly as claimed in claim 3, wherein the maximum amplitude of  
25 the cyclical movement of the piston is limited by the physical movement of the spring and the stroke of the piston, i.e. the crank throw, so no uncontrolled oscillation can occur.
5. An assembly as claimed in claim 4, wherein the spring/flywheel

assembly has a resonant frequency which occurs at the same frequency as that dictated by the engine's speed (rpm), and at which the engine will require a minimum input of fuel to sustain this frequency.

5 6. An assembly as claimed in claim 5, wherein inbuilt friction in the engine will exert damping on this frequency, which will have the effect of reducing its effectiveness at the resonant frequency, but will extend the bandwidth of the response curve, thereby improving the engine's performance over a wider range of engine speeds.

10

7. An assembly as claimed in claim 6, wherein the inbuilt friction in the system (which results mainly from the need for the piston rings to seal tightly the high pressure in the combustion chamber) results in the spring being easily compressed during the period of combustion around TDC where the side forces on the piston (hence friction on the walls) are a minimum.

8. An assembly as claimed in claim 7, wherein, after TDC, the cylinder pressure rises to a maximum value at around  $12^\circ$  after TDC and then falls inversely to cylinder volume, so the side thrust on the walls after TDC will approximately follow the product of the sine of the angle of rotation and the cylinder pressure.

9. A stack of disc springs for incorporation in a piston and connecting rod assembly to act between the piston rod and the connecting rod of said assembly, wherein the disc springs are so profiled that adjacent contacting surfaces of each pair of adjacent disc springs roll against one another as the stack of disc springs is compressed or decompressed.

10. A spring stack as claimed in claim 9, wherein said contacting surfaces

each have a generally part-circular profile.

11. A spring stack as claimed in claim 10, wherein the outer peripheral surface of each disc spring has a semi-circular profile.

5

12. A spring stack as claimed in any one of claims 9 to 11, wherein the disc springs are made of a titanium alloy such as titanium Timetal 15-3.

13. A spring stack as claimed in claim 12, wherein the springs are subjected to ageing at a high temperature, followed by air cooling.

10

14. A spring stack as claimed in any one of claims 9 to 13, wherein at least the contacting surfaces of the springs are vibro-polished and shot peened, after ageing, to produce a fine, smooth, blemish-free finish.

15

15. A spring stack as claimed in claim 14, wherein the entire surfaces of the springs are vibro-polished and shot peened, after ageing, to produce a fine, smooth, blemish-free finish.

1/5

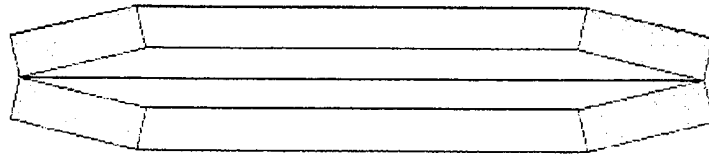

Fig 1

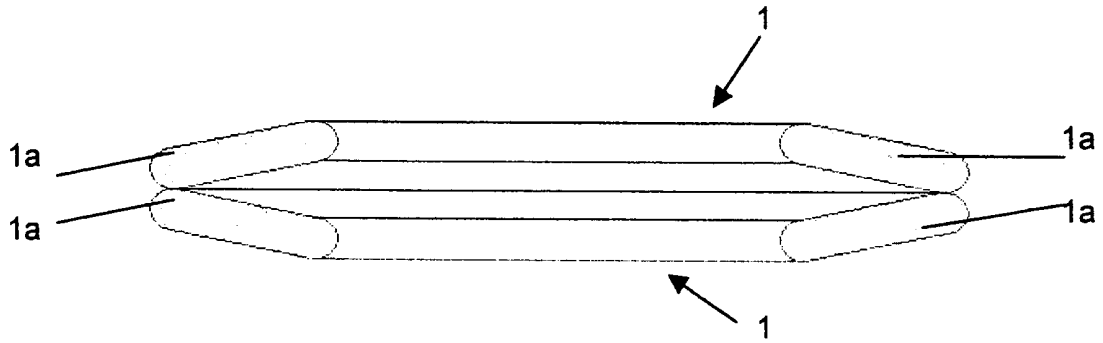

Fig 4

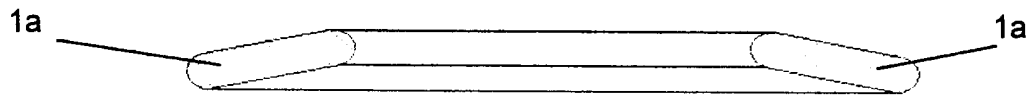

Fig 5

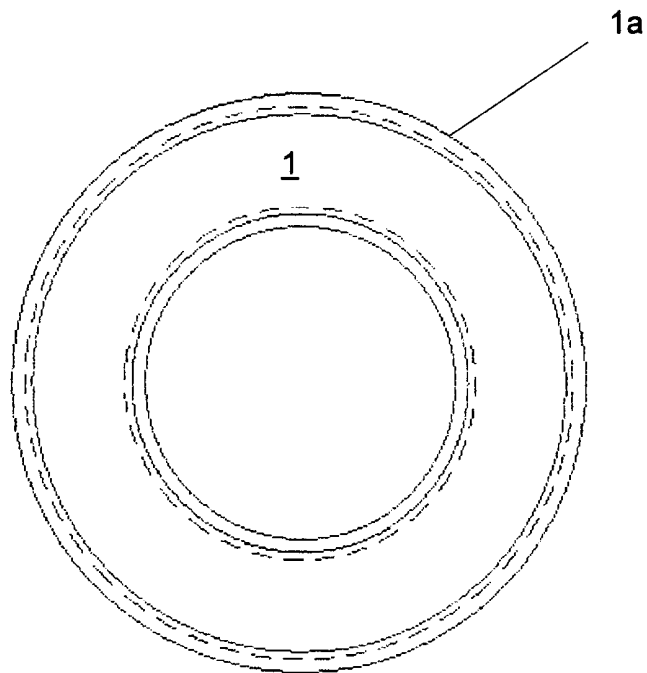

Fig 6

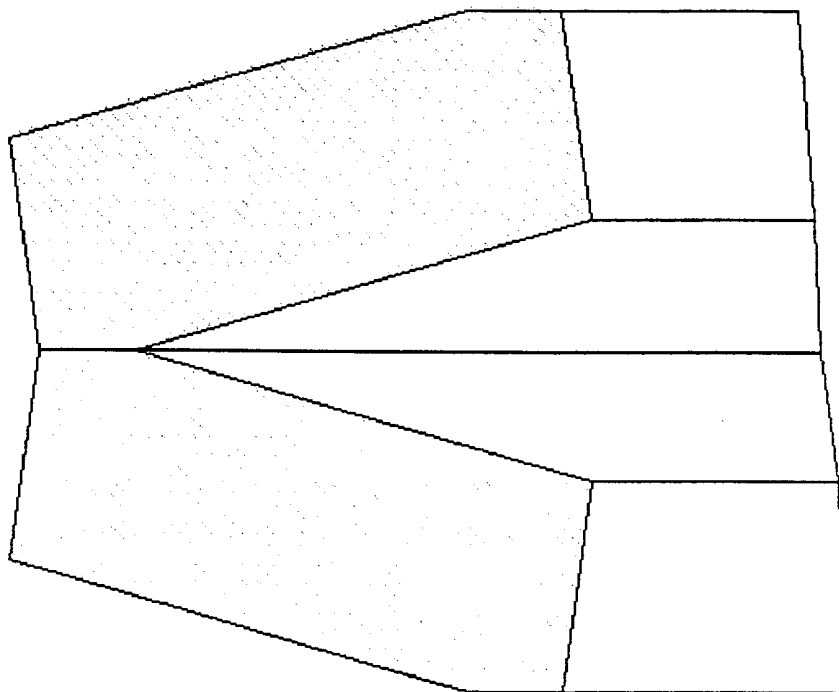

Fig2

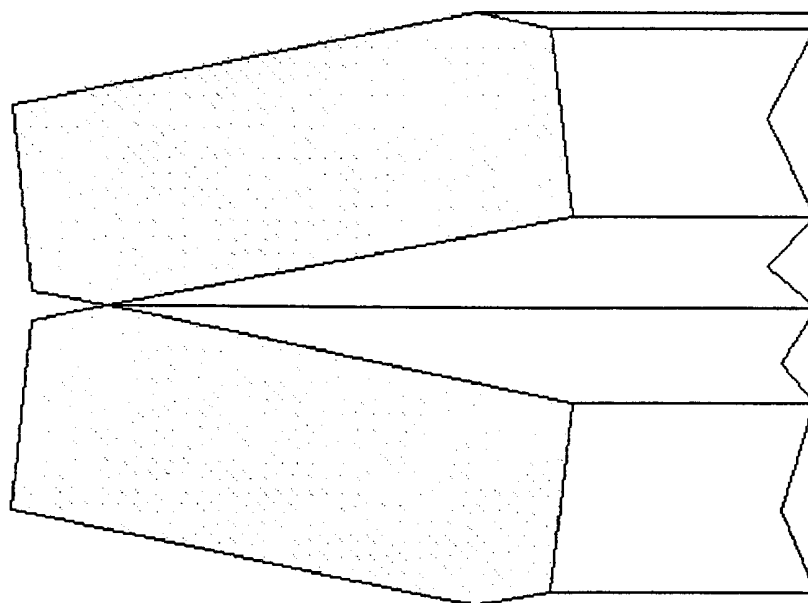

Fig3

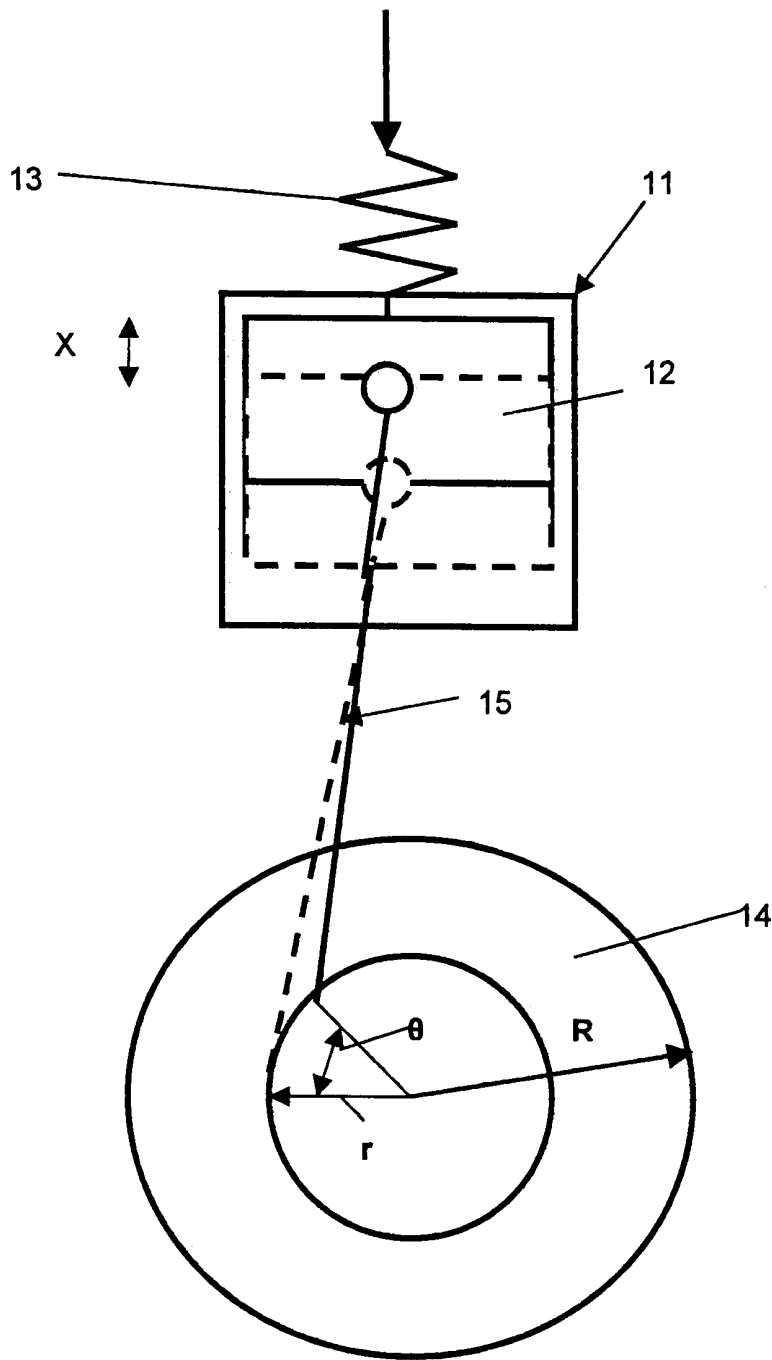

Fig 7

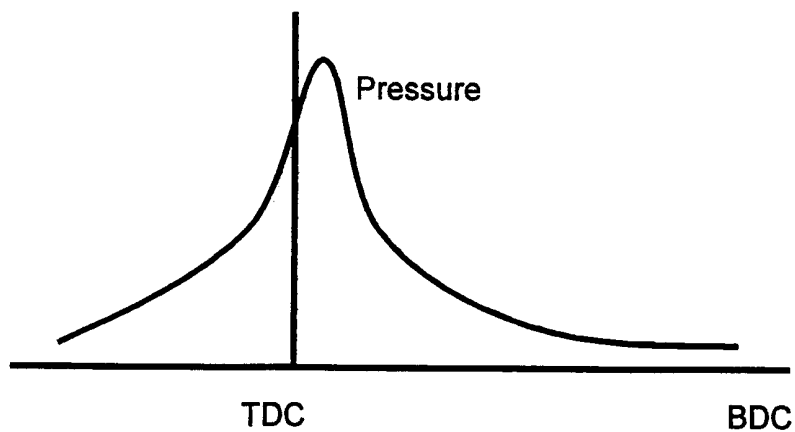

Fig 8

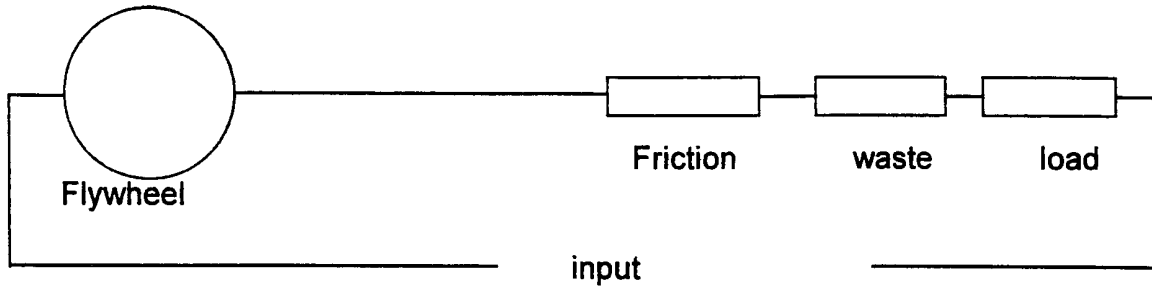

Fig 9

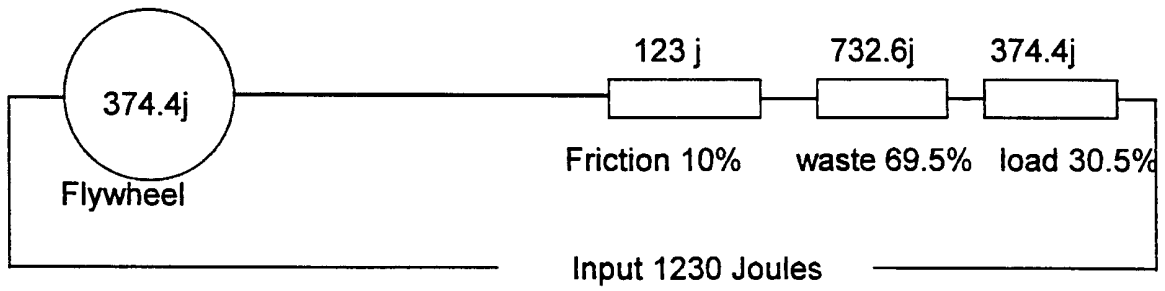

Fig 10

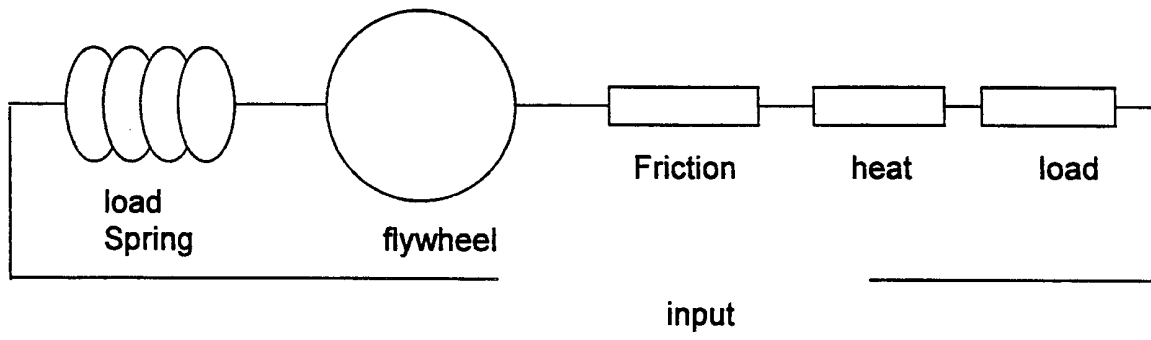

Fig11

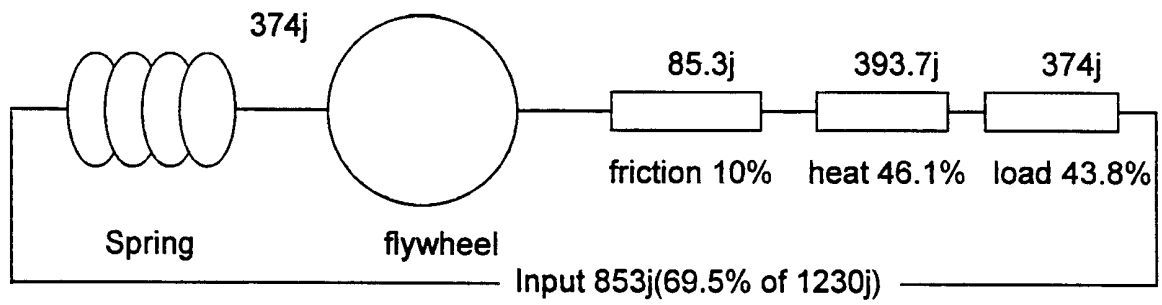

Fig12