

(19) **DANMARK**

(10) **DK/EP 2473079 T3**



(12) **Oversættelse af
europæisk patentskrift**

Patent- og
Varemærkestyrelsen

-
- (51) Int.Cl.: **A 47 C 4/02 (2006.01)**
- (45) Oversættelsen bekendtgjort den: **2018-01-08**
- (80) Dato for Den Europæiske Patentmyndigheds bekendtgørelse om meddelelse af patentet: **2017-09-20**
- (86) Europæisk ansøgning nr.: **10752408.4**
- (86) Europæisk indleveringsdag: **2010-08-06**
- (87) Den europæiske ansøgnings publiceringsdag: **2012-07-11**
- (86) International ansøgning nr.: **IB2010053571**
- (87) Internationalt publikationsnr.: **WO2011027245**
- (30) Prioritet: **2009-09-03 IT PD20090250**
- (84) Designerede stater: **AL AT BE BG CH CY CZ DE DK EE ES FI FR GB GR HR HU IE IS IT LI LT LU LV MC MK MT NL NO PL PT RO SE SI SK SM TR**
- (73) Patenthaver: **Arper S.p.A., Via Lombardia, 16, 31050 Monastier di Treviso (TV), Italien**
- (72) Opfinder: **FELTRIN, Claudio, c/o Arper S.p.A., Via Lombardia 16, I-31050 Monastier di Treviso, Italien**
- (74) Fuldmægtig i Danmark: **NORDIC PATENT SERVICE A/S, Bredgade 30, 1260 København K, Danmark**
- (54) Benævnelse: **SÆDEELEMENT**
- (56) Fremdragne publikationer:
WO-A1-2008/140752
US-A1- 2004 245 840
US-A1- 2006 273 642

DESCRIPTION

[0001] The present invention relates to a seat element such as a chair, a stool and the like, comprising a frame and a seat made separately and assembled together.

[0002] It is known of in the art to make seats and frames separately, preferably in different materials, to later assemble them together. The interconnection of the seat and the frame is usually performed using rivets, bolts or screws passing through the seat so as to engage in relative holes made in the frame. Other solutions comprise snap coupling elements placed between the seat and frame: see for example WO 2008/140752 A.

[0003] Such structures however present the drawback of requiring for their assembly riveting machines or staff specialised in assembling and connecting parts using the aforesaid means of connection.

[0004] For such reason, the seat elements of the prior art are normally assembled during the production phase so that the final product is a chair or stool already assembled and ready for use.

[0005] The pre-assembled structure has the disadvantage however of being cumbersome and unwieldy both during storage and relative transport.

[0006] Seat element structures in two separate parts having attachment devices and shaped couplings between relative counter-shaped portions of the frame and the seat are also known of in the art.

[0007] Such attachment devices and shaped couplings do not however ensure a safe and stable attachment over time: in other words with wear, and on account of the inevitable production tolerance, there is often unacceptable and annoying play between the seat and the frame.

[0008] Furthermore, the attachment devices of the known art tend to break during assembly and often ruin the seat by abrasion during assembly and subsequent dismantling phases.

[0009] The deterioration of the seat, even if on the under part of the seat and therefore not very visible, is not acceptable in the case in which the seat is, for example, upholstered in valuable material. Furthermore, in the case of an upholstered seat, the friction and damage of the covering may lead to jamming of the mechanism.

[0010] The purpose of the present invention is to make a seat element which overcomes the drawbacks mentioned with reference to the prior art.

[0011] Such drawbacks and limitations are resolved by a seat element according to claim 1.

[0012] Other embodiments of the seat according to the invention are described in the claims below.

[0013] Further characteristics and advantages of the present invention will be more comprehensible from the description below of its preferred embodiments, made by way of a non-limiting example wherein:

figure 1 shows a perspective view in separate parts of a seat element according to one embodiment of the present invention;

figure 2 shows a ground view from below of the seat element in figure 1, in an assembled configuration;

figure 3 shows a cross-section view of the seat element in figure 1, along the section plane III-III in figure 2;

figures 4-6 show enlarged perspective views of the phases of the assembly process of the seat element in figure 1;

figures 7-8 respectively shows a front view and a ground view from below of a seat element according to a further embodiment of the present invention, in an assembled configuration.

[0014] The elements or parts of elements common to the embodiments described below will be indicated using the same reference numeral.

[0015] With reference to the aforesaid figures, reference numeral 4 globally denotes a seat element; the seat element may be of any type, such as, for example, a chair, a stool or even an armchair or a sump chair.

[0016] The seat element 4 comprises a frame 8 able to support an associable seat 12 and fitted with at least one means of support 16, such as a foot or a leg.

[0017] The frame 8 is preferably made in metal and is of the tubular type. The means of support 16 may be of any type, such as for example a plurality of legs, a central column fitted with arms, with or without castors, and so on.

[0018] The seat 12 may be of various shapes, materials and sizes and may be with or without a backrest 20.

[0019] The frame 8 and the seat 12 are made separately from each other and can be attached and detached from each other, as better described below.

[0020] According to the invention, the frame (8) comprises at least one lateral plate (24), and the seat (12) comprises at least one tab (28) which in an assembled configuration, hooks onto said lateral plate (24) at least partially, in a shaped coupling.

[0021] According to the invention between the at least one tab (28) and the at least one plate (24) a snap coupling element (32) is positioned, flexible in relation to the plate (24) and to the tab (28) so as to block the seat (12) to the frame (8) in an assembled configuration of the seat element (4).

[0022] According to one embodiment, the at least one plate 24 has a snap coupling element 32, flexible in relation to the at least one plate 24 and at least one tab 28, and the tab 28 comprises at least one connection seat 36 able to receive the snap coupling element 32 of the plate 24, so as to block the seat 12 to the frame 8 in an assembled configuration of the seat element 4.

[0023] Preferably, the seat 12 comprises a pair of tabs 28 and the frame 8 comprises a pair of lateral plates 24 which, in an assembled configuration, guide the relative sliding between the seat 12 and the frame 8 in an axial direction X-X essentially parallel to a seat plane 40.

[0024] Preferably, the lateral plates 24 are positioned to overhang the frame 8, at the lateral extremities 42 of the frame 8.

[0025] According to one embodiment, the tabs 28 of the seat 12 define cavities 44 with a lower wall 48 of the seat 12 and said cavities 44 house the tabs 28 at least partially, in an assembled configuration of the seat element 4.

[0026] Preferably, the lateral plates 24 and the cavities 44 are directed in an axial direction X-X, so as to form a prismatic coupling along said axial direction X-X. Prismatic coupling is taken to mean a coupling of pure translatory movement which prevents a relative rotation between the two coupled elements.

[0027] According to one embodiment, the snap coupling element 32 is a spring 52 having an attachment base 56 attached to the frame 8 and a cantilevered flexible arm 60 provided with one free extremity 64 able to snap engage into the connection seats 36 of the tabs 28 of the seat 12. For example the flexible cantilever arm 60 is connected to the attachment base 56 by a connection portion, for example arc-shaped.

[0028] Preferably, the attachment base 56 is positioned towards the means of support 16, on the side opposite the associable seat 12, so as not to interfere with the seat plane 40.

[0029] In other words, the attachment base 56 is attached to the lateral plate 24 of the frame 8 so as not to interfere with the shaped coupling between the lateral plate 24 and the tab 28.

[0030] Preferably, in an idle condition, the flexible cantilever arm 60 is at least partially closed

towards the attachment base 56, so that the free extremity 64 of the spring 52 intersects a plane passing through said attachment base 56.

[0031] According to one embodiment, the plate 24 comprises, at the height of the snap coupling element 32, a through aperture 68 able to allow the passage of said free extremity 64 of the spring 52.

[0032] The free extremity 64 is fitted with a slot portion 72, on the side opposite the attachment base 56, to facilitate the connection of the spring 52 and a front rim 76 of the tabs 28 of the seat 12, during assembly of the seat element 4 in an insertion direction A.

[0033] The free extremity 64, on the side opposite the slot portion 72 has a pawl 80 able to prevent relative withdrawal of the seat 12 from the frame 8 in a withdrawal direction B opposite said insertion direction A.

[0034] Preferably, the length of the flexible cantilever arm 60 of the spring 52 is such that, in a connection configuration of the free extremity 64 in the connection seat 36, a connection portion 66 between the flexible cantilever arm 60 and the attachment base 56 reaches its final position against a front rim 76 of the tabs 28, so as to form a limit stop to the coupling of the seat 12 and the frame 8.

[0035] Preferably, the spring 52 is positioned at a rear extremity 84 of the plate 24, on the side opposite the front extremity 88 of the plate 24 suitable for being coupled to a front rim 76 of the tabs 28 of the seat 12; this way the spring 52 prevents reverse assembly of the seat 12 on the side of said rear extremity 84 of the plate 24.

[0036] The spring 52 is preferably of the leaf type with a rectangular cross-section. Preferably the spring is made from crude steel so as to yield to the tabs 28 and to the plates 24.

[0037] The method of assembling a seat element according to the invention will now be described.

[0038] In particular, the frame 8 is assembled and the seat 12 brought up to it so as to insert the front extremity 88 of the plates 24 into the cavities 44 delimited by the tabs 28 (figure 4).

[0039] During the coupling of the plates 24 and the tabs 28, near the limit stop of the coupling, the front rim 76 of the tabs 28 intercepts the free extremity 64 of the spring 52. This way the flexible cantilever arm 60 rises flexibly to allow the sliding of the tabs (figure 5) until the free extremity encounters the connection seat 36 with which it snap couples (figure 6). Preferably, the limit stop occurs contemporarily with the contact between the front rim 76 of the tabs 28 and the connection portion 66 of the spring 52.

[0040] Lastly, to dismantle the seat element 4, it is sufficient to flexibly press the springs 52 so

as to disengage the free end 64 from the connection seat 36 and contemporarily slide the seat 12 in relation to the frame 8 so as to pull out the plates 24 from the tabs 28 completely.

[0041] For example, a screwdriver may be used for this purpose, inserting the tip between the flexible cantilever arm 60 of the spring 52 and the tab 28 of the seat 12.

[0042] As may be appreciated from the description, the seat element according to the invention makes it possible to overcome the drawbacks spoken of in relation to the prior art.

[0043] In particular, the seat element is particularly practical and easy to assemble and dismantle.

[0044] The coupling and detachment element does not cause any abrasion of the seat or seat covering where present.

[0045] The coupling element is sturdy and does not break even if the assembly and dismantling phase is performed repeatedly.

[0046] The coupling element is small and practically invisible in conditions of normal use of the seat element.

[0047] The cost of producing and assembling the coupling element is extremely limited and does not substantially influence the overall cost of the seat element.

[0048] Thanks to the present invention it is possible to store and transport the seat elements in an easy and practical manner.

[0049] Lastly, the number of machines and the labour used to produce the seat elements is reduced.

[0050] A person skilled in the art may make numerous modifications and variations to the seat elements described above so as to satisfy contingent and specific requirements while remaining within the sphere of protection of the invention as defined by the following claims.

REFERENCES CITED IN THE DESCRIPTION

This list of references cited by the applicant is for the reader's convenience only. It does not form part of the European patent document. Even though great care has been taken in compiling the references, errors or omissions cannot be excluded and the EPO disclaims all liability in this regard.

Patent documents cited in the description

- WO2008140752A [0002]

PATENTKRAV

1. Sædeelement (4), der omfatter
 - en ramme (8), der kan understøtte et sæde (12), der kan tilkobles, og er udstyret med mindst ét støttemiddel (16), såsom en fod eller et ben,
 - 5 - et sæde (12), der kan kobles på rammen (8),
 - hvor rammen (8) og sædet (12) er fremstillet separat og kan fastgøres til eller adskilles fra hinanden ved hjælp af et snapkoblingselement (32),
kendetegnet ved, at
 - rammen (8) omfatter mindst én sideplade (24),
 - 10 - sædet (12) omfatter mindst ét vinkelbeslag (28), der i en monteret konfiguration kroges fast på sidepladen (24) mindst delvist, i en forment kobling, hvor
 - mellem det mindst ene vinkelbeslag (28) og mindst ene plade (24) snapkoblingselementet (32) er placeret, der er fleksibelt i forhold til pladen (24) og til vinkelbeslaget (28) for således at blokere sædet (12) til rammen (8) i en monteret konfiguration af sædeelementet (4).
- 15 2. Sædeelement (4) ifølge krav 1, hvor den mindst ene plade (24) har et snapkoblingselement (32), der er fleksibelt i forhold til den mindst ene plade (24) og det mindst ene vinkelbeslag (28), og hvor vinkelbeslaget (28) omfatter mindst ét tilkoblingssæde (36), der kan modtage pladens (24) snapkoblingselement (32), for således at blokere sædet (12) til rammen
20 (8) i en monteret konfiguration af sædeelementet (4).
3. Sædeelement (4) ifølge krav 1 eller 2, hvor sædet (12) omfatter et par vinkelbeslag (28) og rammen (8) omfatter et par sideplader (24), der, i en monteret konfiguration, styrer den relative glidning mellem sædet (12) og rammen (8) i en aksial retning (X-X), navnlig parallelt
25 med et sædeplan (40).
4. Sædeelement (4) ifølge krav 1, 2 eller 3, hvor sædets (12) vinkelbeslag (28) definerer hulrum (44) med en nedre væg (48) af sædet (12) og hulrummene (44) rummer vinkelbeslagene (28) mindst delvist i en monteret konfiguration af sædeelementet (4).
- 30 5. Sædeelement (4) ifølge et hvilket som helst af de foregående krav, hvor sidepladerne (24) og hulrummene (44) er dirigeret i en aksial retning (X-X) for således at danne en prismatisk kobling langs den aksiale retning (X- X).

6. Sædeelement (4) ifølge et hvilket som helst af de foregående krav, hvor sidepladerne (24) er placeret til at hænge ud over rammen (8), ved rammens (8) sideender (42).
7. Sædeelement (4) ifølge et hvilket som helst af de foregående krav, hvor
5 snapkoblingselementet (32) er en fjeder (52) med en fastgøringsbase (56) fastgjort til rammen (8) og en fleksibel udliggerarm (60) forsynet med én fri ende (64), der kan snapkobles i indgreb med forbindelsessæderne (36) af sædets (12) vinkelbeslag (28)
8. Sædeelement (4) ifølge krav 7, hvor fastgøringsbasen (56) er placeret mod støttemidlet
10 (16), på siden modsat sædet (12), der kan tilkobles, for ikke at interferere med sædeplanet (40).
9. Sædeelement (4) ifølge krav 7 eller 8, hvor, i en fri tilstand, den fleksible udliggerarm (60) er mindst delvist lukket mod fastgøringsbasen (56), således at fjederens (52) frie ende (64) skærer et plan, der går gennem fastgøringsbasen (56).
- 15
10. Sædeelement (4) ifølge et hvilket som helst af de foregående krav fra 7 til 9, hvor pladen (24) omfatter, ved højden af snapkoblingselementet (32), en gennemgående åbning (68), der kan muliggøre passage af fjederens (52) frie ende (64).
- 20
11. Sædeelement (4) ifølge et hvilket som helst af de foregående krav fra 7 til 10, hvor den frie ende (64) er udstyret med en spaltetdel (72), på siden modsat fastgøringsbasen (56), for at lette tilkobling af fjederen (52) og en forkant (76) af sædets (12) vinkelbeslag (28) under montering af sædeelementet (4) i en indføringsretning (A).
- 25
12. Sædeelement (4) ifølge krav 11, hvor den frie ende (64) modsat spaltetdelen (72) har en pal (80), der kan forhindre relativ tilbagetrækning af sædet (12) fra rammen (8) i en tilbagetrækningsretning (B) modsat indføringsretningen (A).
- 30
13. Sædeelement (4) ifølge et hvilket som helst af de foregående krav fra 7 til 12, hvor længden af fjederens (52) fleksible udliggerarm (60) er således, at, i en tilkoblingskonfiguration af den frie ende (64) i forbindelsessædet (36), en tilkoblingsdel (66) mellem den fleksible udliggerarm (60) og fastgøringsbasen (56) når sin slutposition mod en forkant (76) af vinkelbeslagene (28) for således at danne en stopgrænse for sammenkoblingen af sædet (12) og rammen (8).

14. Sædeelement (4) ifølge et hvilket som helst af de foregående krav fra 7 til 13, hvor fjederen (52) er placeret ved en bagende (84) af pladen (24), på siden modsat pladens (24) forende (88), der er egnet til at blive koblet til en forkant (76) af sædets (12) vinkelbeslag (28),
5 hvor fjederen (52) forhindrer omvendt montering af sædet (12) på siden for pladens (24) bagende (84).
15. Sædeelement (4) ifølge et hvilket som helst af de foregående krav fra 7 til 13, hvor fjederen (52) er fremstillet af råstål for således at give efter for vinkelbeslagene (28) og pladerne
10 (24).

DRAWINGS

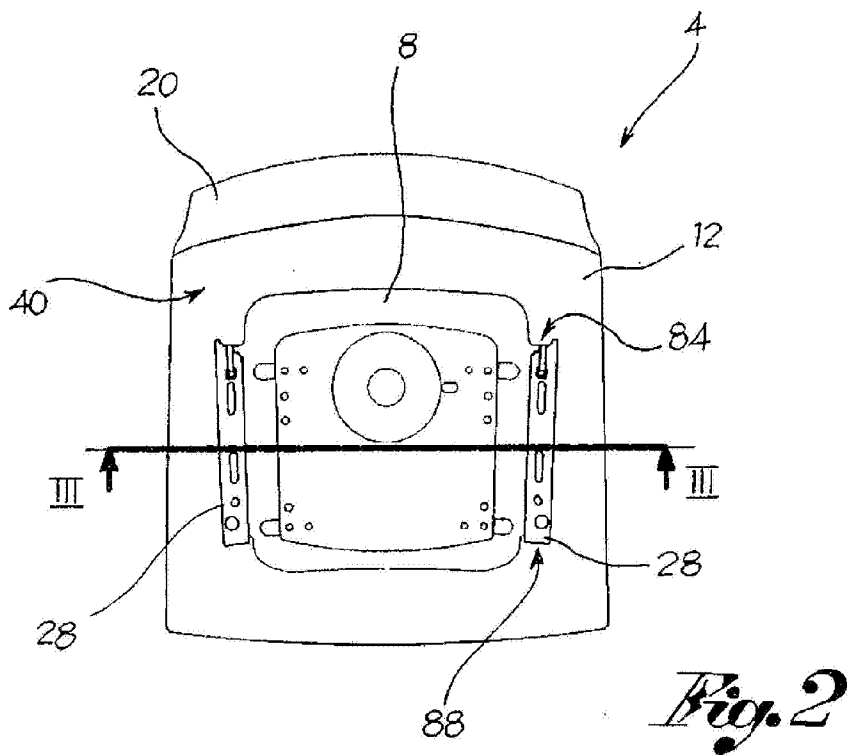
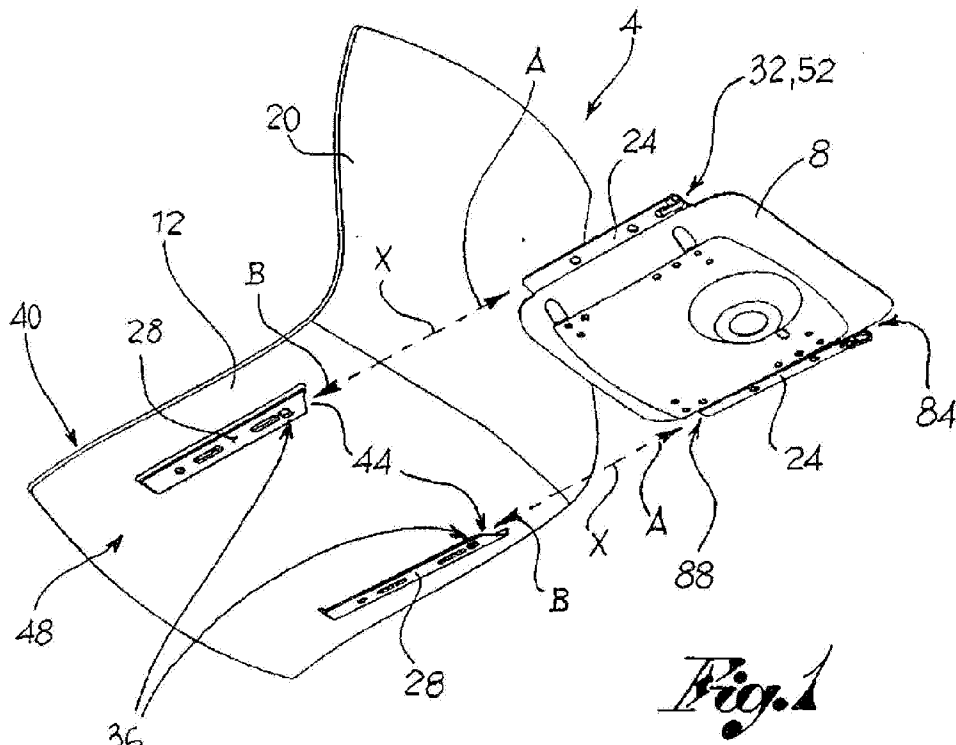

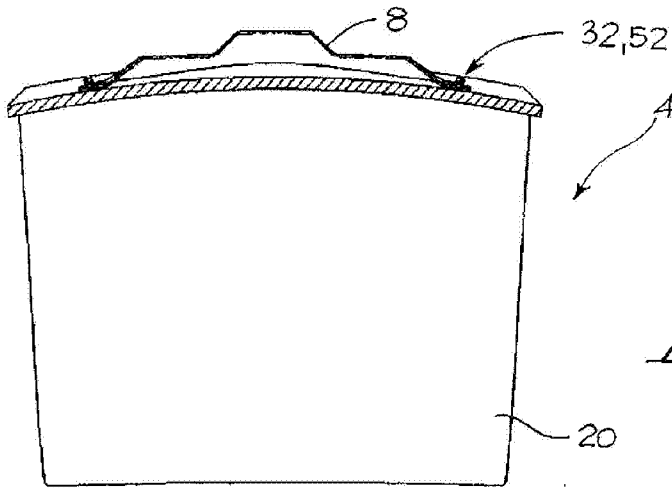

Fig. 3

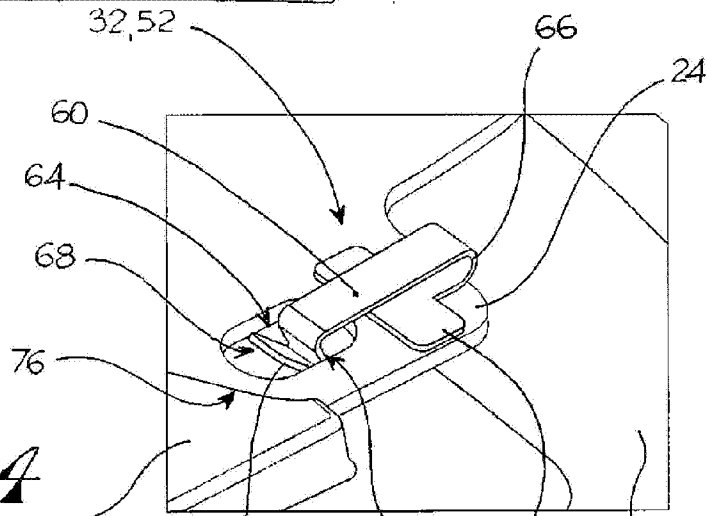

Fig. 4

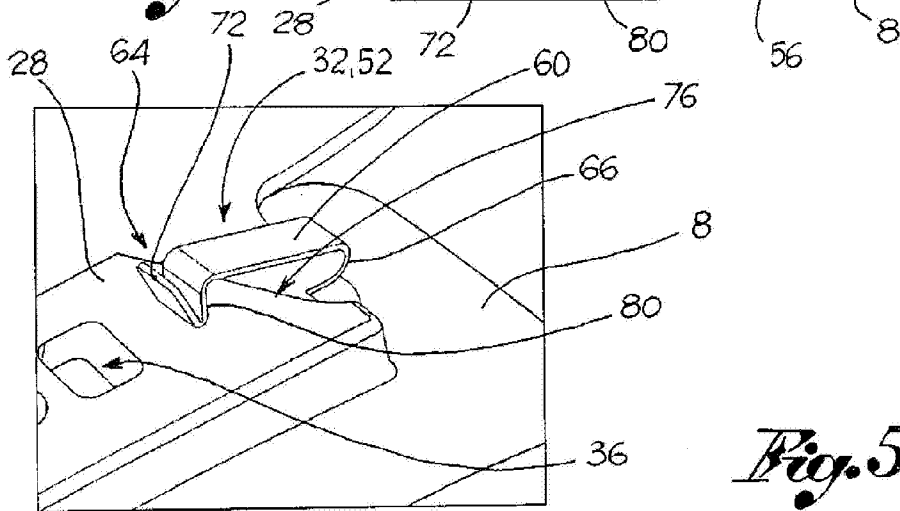

Fig. 5

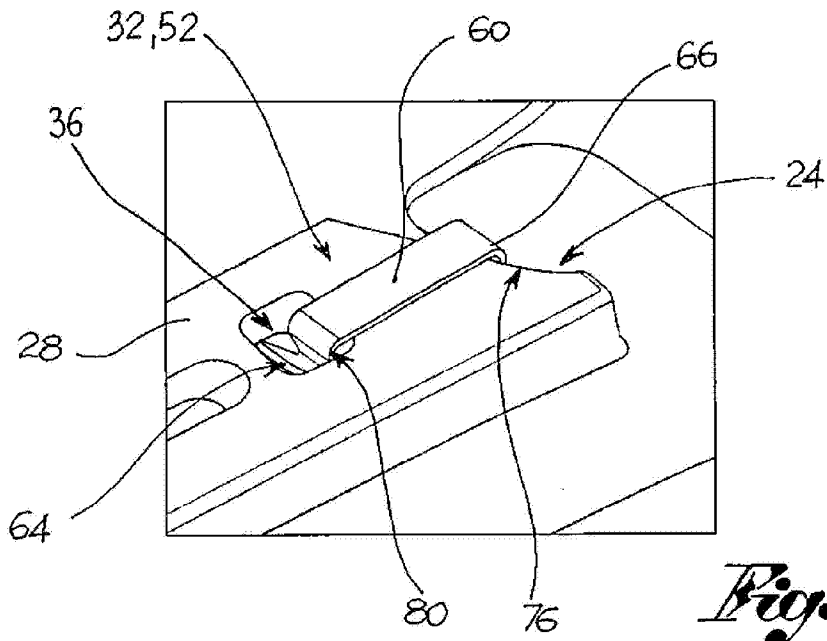

Fig. 6

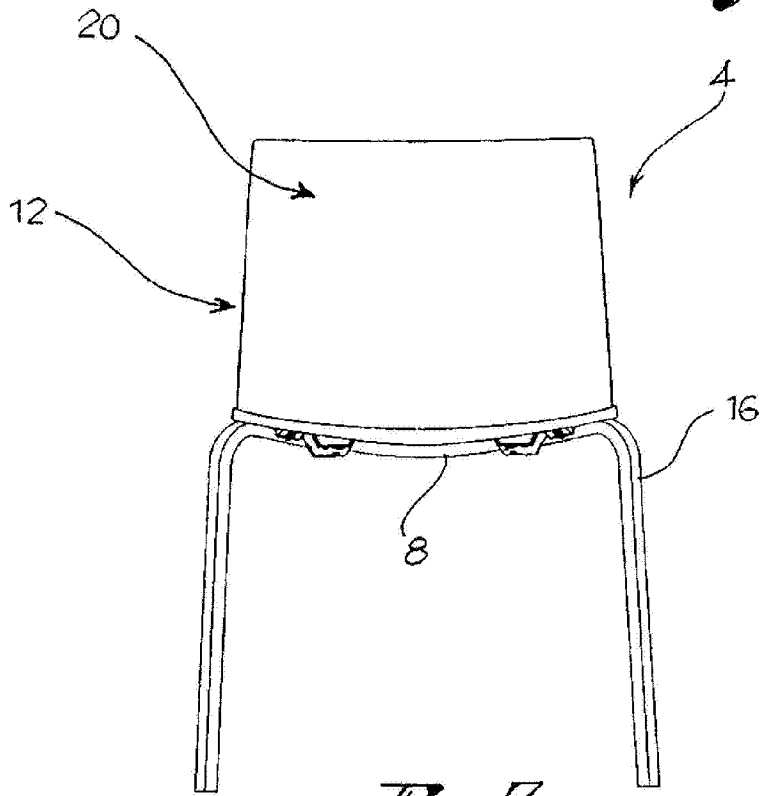

Fig. 7

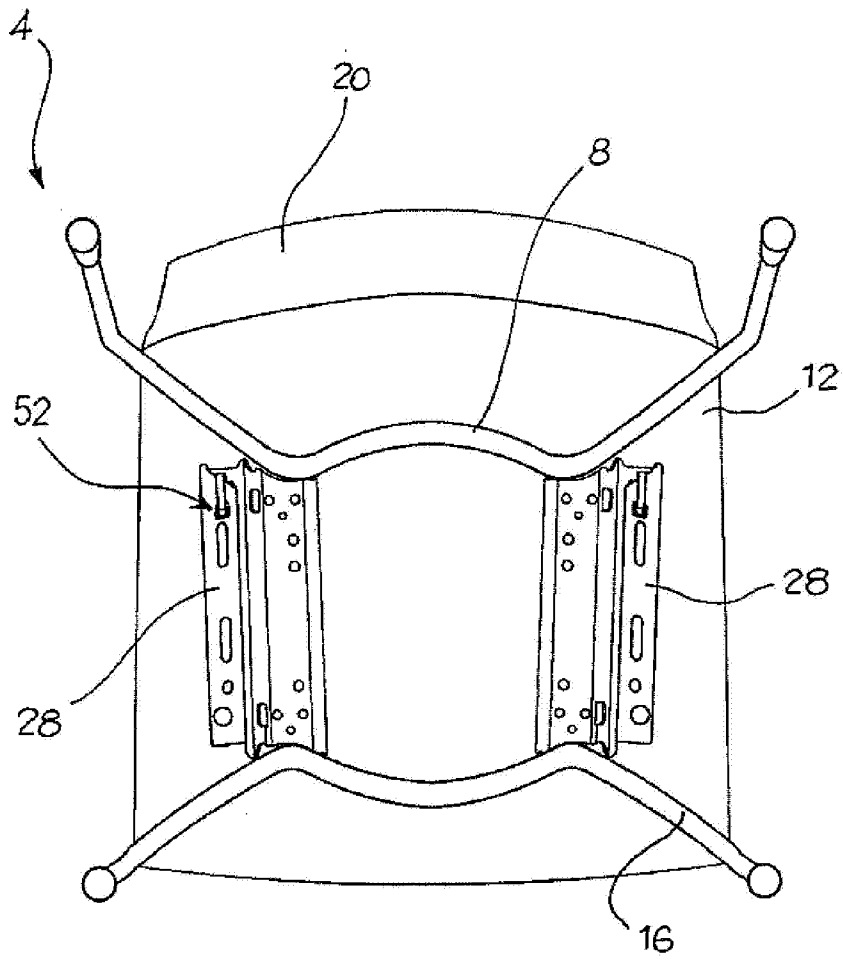

Fig. 8