

(19) World Intellectual Property Organization
International Bureau



(43) International Publication Date
21 February 2002 (21.02.2002)

PCT

(10) International Publication Number
WO 02/14005 A1

- (51) International Patent Classification⁷: **B23C 5/10**, (74) Agent: **ISCAR LTD.**; Patent Department, P.O. Box 11, 24959 Tefen (IL).
B23B 31/11
- (21) International Application Number: PCT/IL01/00711 (81) Designated States (*national*): AE, AG, AL, AM, AT, AU, AZ, BA, BB, BG, BR, BY, BZ, CA, CH, CN, CO, CR, CU, CZ, DE, DK, DM, DZ, EC, EE, ES, FI, GB, GD, GE, GH, GM, HR, HU, ID, IL, IN, IS, JP, KE, KG, KP, KR, KZ, LC, LK, LR, LS, LT, LU, LV, MA, MD, MG, MK, MN, MW, MX, MZ, NO, NZ, PL, PT, RO, RU, SD, SE, SG, SI, SK, SL, TJ, TM, TR, TT, TZ, UA, UG, US, UZ, VN, YU, ZA, ZW.
- (22) International Filing Date: 31 July 2001 (31.07.2001)
- (25) Filing Language: English
- (26) Publication Language: English
- (30) Priority Data: 137945 18 August 2000 (18.08.2000) IL
- (71) Applicant (*for all designated States except US*): **ISCAR LTD.** [IL/IL]; P.O. Box 11, 24959 Tefen (IL).
- (72) Inventors; and
- (75) Inventors/Applicants (*for US only*): **HARPAZ, Jacob** [IL/IL]; Hiram Street 5, 25147 Tefen (IL). **SATRAN, Amir** [IL/IL]; Moran Street 6, 25147 Tefen (IL). **PETRILIN, Andrei** [IL/IL]; Pinsker Street 38, Apt. #4, 28012 Qiryat Ata (IL).
- (84) Designated States (*regional*): ARIPO patent (GH, GM, KE, LS, MW, MZ, SD, SL, SZ, TZ, UG, ZW), Eurasian patent (AM, AZ, BY, KG, KZ, MD, RU, TJ, TM), European patent (AT, BE, CH, CY, DE, DK, ES, FI, FR, GB, GR, IE, IT, LU, MC, NL, PT, SE, TR), OAPI patent (BF, BJ, CF, CG, CI, CM, GA, GN, GQ, GW, ML, MR, NE, SN, TD, TG).
- Published:
— with international search report

[Continued on next page]

(54) Title: CUTTING TOOL ASSEMBLY

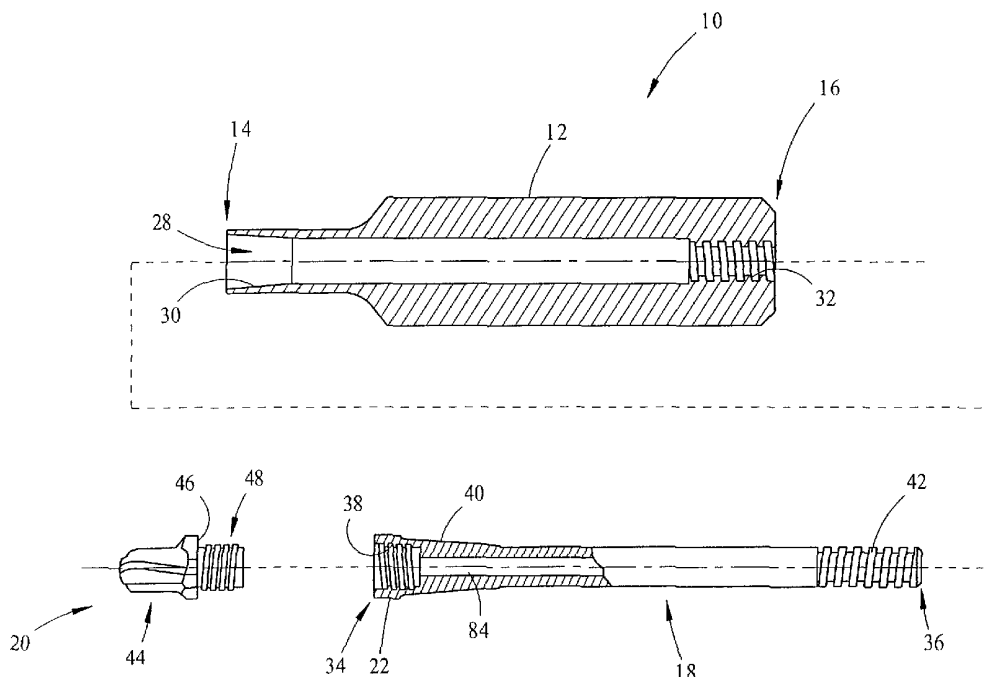

(57) Abstract: The present invention provides a cutting tool assembly (10) having a tool shank (12) with an elongated hole (28) extending axially through the tool shank (12). An elongated support bar (18) having threaded bore (38) at its forward end (34) is retained in the elongated hole (28). A cutting head (20) having a forward cutting portion (44) and a rear threaded portion (48) is retained in the support bar (18) with its rear threaded portion (48) threadingly engaged with the threaded bore (38) in the forward end (34) of the support bar (18).



WO 02/14005 A1



For two-letter codes and other abbreviations, refer to the "Guidance Notes on Codes and Abbreviations" appearing at the beginning of each regular issue of the PCT Gazette.

CUTTING TOOL ASSEMBLY

FIELD OF THE INVENTION

This invention relates generally to cutting tool assemblies for metal cutting machining having a replaceable cutting head, and more particularly to cutting tool assemblies having an elongated shank for rotary cutting operations.

5

BACKGROUND OF THE INVENTION

Such cutting tool assemblies have long been known. It has been proposed in EP 0 298 937 B1, to provide a cutting tool comprising a cutting body and a shaft that supports the cutting body. The cutting body is detachably connected to a locking screw via hook-shaped means. The hooked-shaped means transfers axial forces between the cutting body and the locking screw. Both the cutting body and the locking screw are provided with hook shaped means. Both of the hooked shaped means are provided with recesses and tongues. The recesses and tongues cooperate to permanently transfer rotational movement between the locking means and the cutting body. The locking screw is provided with an externally threaded portion that is connected to an internally threaded recess provided in the shaft. The threads are designed as right hand threads for right hand cutting tools and as left hand threads for left hand cutting tools. The locking screw is movable in the axial direction by relative rotation of the externally threaded portion with respect to the internally threaded recess. The shaft is provided with a conical seat and the cutting

10
15
20

body is provided with a circumferential conical portion that is received in the conical seat of the shaft. The cutting body can be inserted in or removed from the conical seat by displacing the locking screw from its innermost position to an intermediate position.

5 The prior art cutting tool described above suffers from two basic disadvantages. First, to insert or remove the cutting body from the shaft the locking screw has to be displaced from its innermost position to an intermediate position. Second, the cutting body cannot be used in any other type of tool since it is formed with hook-shaped member and therefore it requires the presence of a locking screw
10 having a mating hook-shaped member for coupling it to the shaft.

 It is an object of the present invention to provide a cutting tool assembly that substantially overcomes the above-mentioned disadvantages.

SUMMARY OF THE INVENTION

15 In accordance with the present invention there is provided a cutting tool assembly comprising:

 a tool shank having a forward end, a rear end and a longitudinal axis **A** passing through the forward and rear ends, an elongated hole extending axially from the forward end of the tool shank, adjacent the forward end of the tool shank
20 the elongated hole having a conical portion, the tool shank having a first coupling member adjacent the rear end thereof;

 an elongated support bar having a forward end and a rear end, with a threaded bore extending axially rearwardly from the forward end thereof, the elongated support bar having a conical portion rearward of the forward end thereof, the
25 elongated support bar having a second coupling member adjacent the rear end thereof, the elongated support bar being removably retained in the elongated hole of the tool shank with the first coupling member coupled to the second coupling member and with at least a section of the conical portion of the elongated support bar being in abutment with the conical portion of the elongated hole; and

a cutting head having a forward cutting portion and a rear threaded portion; the rear threaded portion of the cutting head being threadingly engaged with the threaded bore in the forward end of the elongated support bar.

In accordance with a first embodiment of the present invention, the elongated hole has a threaded portion adjacent the rear end thereof and wherein the elongated support bar has an externally threaded portion adjacent the rear end thereof and wherein the elongated support bar is removably retained in the elongated hole of the tool shank with the externally threaded portion of the elongated support bar threadingly engaged with the threaded portion of the elongated hole, the threaded portion of the elongated hole forming the first coupling member and the externally threaded portion of the elongated support bar forming the second coupling member.

In accordance with a second embodiment of the present invention, the tool shank has a threaded through bore passing through a section of the tool shank, the threaded through bore extending from a side opening in the tool shank to the elongated hole, the elongated support bar being removably retained in the elongated hole of the tool shank by a securing screw threadingly retained in the threaded through bore, the securing screw engaging a locking recess formed in the elongated support bar, the securing screw forming the first coupling member and the locking recess of the elongated support bar forming the second coupling member.

In accordance with a third embodiment of the present invention, the cutting tool assembly further comprises a coupling bar generally cylindrically shaped at least a portion of which has an externally threaded surface and having an axially extending through bore with an internally threaded portion, wherein the elongated hole has a threaded portion adjacent the rear end of the tool shank and wherein the elongated support bar has an externally threaded portion adjacent the rear end thereof and wherein the coupling bar is removably retained in the elongated hole of the tool shank adjacent the rear end thereof with the externally threaded surface of the coupling bar threadingly engaged with the threaded portion

of the elongated hole and the elongated support bar is removably retained in the elongated hole with the externally threaded portion of the elongated support bar threadingly engaged with the internally threaded portion of the coupling bar, the internally threaded portion of the coupling bar forming the first coupling member
5 and the externally threaded portion of the elongated support bar forming the second coupling member.

In accordance with a fourth embodiment of the present invention, the cutting tool assembly further comprises a cylindrical sleeve having a non-threaded external cylindrical surface and an axially extending threaded through bore and
10 wherein the elongated hole in the tool shank has a cylindrically shaped rear portion in which the cylindrical sleeve is mounted and wherein the elongated support bar is removably retained in the elongated hole with the externally threaded portion of the elongated support bar in threaded engagement with the threaded through bore in the cylindrical sleeve, the threaded through bore in the cylindrical sleeve forming the
15 first coupling member and the externally threaded portion of the elongated support bar forming the second coupling member.

In accordance with a fifth embodiment of the present invention, the cutting tool assembly further comprises a cylindrical sleeve having a non-threaded external cylindrical surface and an axially extending threaded through bore and
20 wherein the elongated hole in the tool shank has a cylindrically shaped rear portion in which the cylindrical sleeve is mounted and wherein the cutting tool assembly further comprises a coupling bar generally cylindrically shaped, at least a portion having an externally threaded surface and having an axially extending through bore with an internally threaded portion, and the coupling bar is removably retained in
25 the cylindrical sleeve with the externally threaded surface of the coupling bar in threaded engagement with the threaded through bore of the cylindrical sleeve and the elongated support bar is removably retained in the elongated hole of the tool shank with the externally threaded portion of the support bar in threaded engagement with the internally threaded portion of the coupling bar, the internally

threaded portion of the coupling bar forming the first coupling member and the externally threaded portion of the elongated support bar forming the second coupling member.

5 If desired, the elongated support bar is provided with a coolant channel for conducting a coolant fluid, the coolant channel extending axially from the rear end to the forward end of the elongated support bar, and the cutting head is provided with a coolant channel extending through the rear threaded portion thereof and exiting the cutting head at exit openings formed in the forward cutting portion thereof.

10 If desired, the tool shank of the fourth or fifth embodiments of the present invention is made of cemented carbide.

Typically, the cylindrical sleeve is mounted in the tool shank by heat shrink-fit techniques.

15 Further typically, the cylindrical sleeve is mounted in the tool shank by soldering.

BRIEF DESCRIPTION OF THE DRAWINGS

For a better understanding the invention will now be described, by way of example only, with reference to the accompanying drawings in which:

20 **Fig. 1** is a side view of a cutting tool assembly in accordance with the present invention;

Fig. 2 is a partially sectioned exploded side view of a first embodiment of the cutting tool assembly shown in Fig. 1;

25 **Fig. 3** is a partially sectioned exploded side view of a second embodiment of the cutting tool assembly shown in Fig. 1;

Fig. 4 is a partially sectioned exploded side view of a third embodiment of the cutting tool assembly shown in Fig. 1;

Fig. 5 is a partially sectioned exploded side view of a fourth embodiment of the cutting tool assembly shown in Fig. 1; and

Fig. 6 is a partially sectioned exploded side view of a fifth embodiment of the cutting tool assembly shown in Fig. 1.

DETAILED DESCRIPTION OF THE INVENTION

5 Attention is drawn to the drawings in general and to Fig. 1 in particular, showing a cutting tool assembly **10** in accordance with the present invention. In all the drawings the same reference numerals are used to denote identical or similar parts. The cutting tool assembly **10** comprises a tool shank **12** having a forward end **14**, a rear end **16** and a longitudinal axis **A** passing through the forward and
10 rear ends. The tool shank **12** has generally rotational symmetry about the longitudinal axis **A**. The tool shank **12** comprises a forward portion and rear portion, wherein the diameter of the forward portion is preferably smaller than the diameter of the rear portion. As will be described below in greater detail with respect to specific embodiments of the invention, an elongated support bar **18** is
15 removably retained in the tool shank **12** and a cutting head **20** is removably retained in the elongated support bar **18**.

The elongated support bar **18** has a forward end **34** and a rear end **36** and preferably has a cylindrical end portion **22** adjacent the forward end **34**. The cylindrical end portion **22** is preferably provided with diametrically opposite flat
20 surfaces **24** for receiving the jaws of a spanner for tightening or loosening the elongated support bar. Similarly, the cutting head **20** is preferably provided with diametrically opposite flat surfaces **26** for receiving the jaws of a spanner for tightening or loosening the cutting head. Generally, the cutting head **20** is made of cemented carbide. The material from which the tool shank **12** is fabricated
25 generally depends on working conditions, tool life and tool accuracy requirements. Typically, the tool shank is made from alloy steel. However, to reduce vibrations, the tool shank is preferably made of a heavy metal such as Tungsten or a Tungsten alloy, or even from a cemented carbide such as Tungsten carbide. As will be explained in greater detail below with respect to Figs. 5 and 6, the use of a

cemented carbide tool shank requires certain modifications in the design of the tool shank as compared with a tool shank made from softer materials.

Although the cylindrical end portion **22** is shown to be of relatively short length in comparison to the overall length of the elongated support bar **18**, this is for illustrational purposes only and it should not be construed as a constraint. In practice, the actual length of the cylindrical end portion **22** is determined by, *inter alia*, machining requirements. Hence, for a given tool shank **12**, the elongated support bar **18** forms an adaptor for using different cutting heads **20** in the cutting tool assembly **10**, wherein the length of the cutting tool assembly can be varied by choosing elongated support bars **18** having cylindrical end portions **22** of different lengths.

Attention is now drawn to Fig. 2 showing a partially sectioned exploded side view of a first embodiment of the cutting tool assembly **10** of the present invention. An elongated hole **28** extends axially from the forward end **14** to the rear end **16** of the tool shank **12**. The elongated hole **28** has a conical portion **30** adjacent the forward end **14** of the tool shank and a threaded portion **32** adjacent the rear end **16** of the tool shank **12**. The conical portion **30** tapers rearwardly from the forward end **14** of the tool shank **12**. The section of the elongated hole **28** rearward of the conical portion **30** is preferably cylindrical. The threaded portion **32** forms a first coupling member of the cutting tool assembly **10**.

A threaded bore **38** extends rearwardly from the forward end **34** of the elongated support bar **18**. The elongated support bar **18** has a conical portion **40** rearward of the forward end **34** thereof. The conical portion **40** tapers rearwardly, preferably, from adjacent the cylindrical portion **22**. The section of the elongated support bar **18** rearward of the conical portion **40** is preferably cylindrical. Also shown in Fig. 2 is the cylindrical end portion **22** between the forward end **34** and the conical portion **40**. The elongated support bar **18** has an externally threaded portion **42** adjacent the rear end **36** thereof. The externally threaded portion **42** constitutes a second coupling member of the cutting tool assembly **10**. The cutting

head **20** has a forward cutting portion **44**, with a rearwardly facing abutment surface **46**, and a rear threaded portion **48**.

In the assembled cutting tool assembly **10** in accordance with the first embodiment of the invention, the elongated support bar **18** is removably retained in the elongated hole **28** of the tool shank **12** with the externally threaded portion **42** in threaded engagement with the threaded portion **32** of the elongated hole **28** and at least a section of the conical portion **40** of the elongated support bar **18** in abutment with the conical portion **30** of the elongated hole **28**. The cutting head **20** is removably retained in the elongated support bar **18** with the rear threaded portion **48** in threaded engagement with the threaded bore **38** in the forward end **34** of the support bar **18**. When the threaded engagement is complete, that is when the cutting head is fully tightened in position, the rearwardly facing abutment surface **46** abuts the forward end **34** of the elongated support bar **18**, as shown in Fig. 1.

Attention is now drawn to Fig. 3 showing a partially sectioned exploded side view of a second embodiment of the cutting tool assembly **10** of the present invention. The cutting head **20** and the elongated support bar **18** are similar to those of the first embodiment. In accordance with the second embodiment, the cutting tool assembly **10** further comprises a coupling bar **50** having the form of a bushing with a generally cylindrical shape and with an axially extending through bore **52**. The coupling bar **50** comprises an internally threaded portion **54** on part of the through bore **52** and an externally threaded surface **56** covering at least a portion of the coupling bar **50**. The diameter of the externally threaded surface **56** is greater than the diameter of the internally threaded portion **54**. The internally threaded portion **54** has the same thread and internal diameter as the threaded portion **32** of the elongated hole **28** of the tool shank of the first embodiment. Therefore, the internally threaded portion **54** of the coupling bar **50** is capable of threadingly engaging the externally threaded portion **42** of the elongated support bar **18**.

In accordance with the second embodiment, the cutting tool assembly has a tool shank **12** with an elongated hole **28** extending axially between the

forward and rear ends thereof. The elongated hole **28** comprises two portions, a forward portion **62** and a rear portion **64**. The forward portion **62** has a conical portion **30** adjacent the forward end **14** of the tool shank **12** and a cylindrical portion **68** extending rearwardly from the conical portion **30**. The rear portion **64** of the elongated hole **28** is cylindrical in shape and has a diameter that is preferably larger than the diameter of the cylindrical portion **68** of the forward portion **62**. The rear portion **64** of the elongated hole **28** has a threaded portion **32** adjacent the rear end **16** of the tool shank **12**. The threaded portion **32** is capable of threadingly engaging the externally threaded surface **56** of the coupling bar **50**. A portion of the through bore **52** adjacent the rear end of the coupling bar **50** forms a socket **70** suitably shaped to receive a key, such as an Allen key, for screwing the coupling member **50** into the tool shank **12**. The internally threaded portion **54** extends rearwardly from the forward end of the coupling bar **50** to the socket **70**. In accordance with the second embodiment, the internally threaded portion **54** of the coupling bar **50** constitutes a first coupling member and the externally threaded portion **42** of the elongated support bar **18** constitutes a second coupling member of the cutting tool assembly **10**.

In the assembled cutting tool assembly **10** in accordance with the second embodiment of the invention, the coupling bar **50** is removably retained in the rear portion **64** of the elongated hole **28** with the externally threaded surface **56** of the coupling bar **50** in threaded engagement with the threaded portion **32** of the rear portion **64** of the elongated hole **28**. The elongated support bar **18** is removably retained in the elongated hole **28** of the tool shank **12** with the externally threaded portion **42** in threaded engagement with the internally threaded portion **54** of the coupling bar **50** and at least a section of the conical portion **40** of the elongated support bar **18** in abutment with the conical portion **30** of the elongated hole **28**. The cutting head **20** is removably retained in the elongated support bar **18** with the rear threaded portion **48** in threaded engagement with the threaded bore **38** in the forward end of the support bar **18**. When the threaded engagement is complete,

that is when the cutting head is fully tightened in position, the rearwardly facing abutment surface 46 abuts the forward end of the elongated support bar 18. Although, in accordance with the second embodiment, the coupling bar 50 is shown to be externally threaded on a rear portion thereof, this arrangement is by no means binding and the coupling bar 50 can be externally threaded on any convenient portion. If desired, the whole of the coupling bar 50 can be externally threaded, as will be illustrated below in Fig. 6 with reference to a fifth embodiment of the invention. Clearly, the location and length of the threaded portion 32 of the of the rear portion of the elongated hole 28 of the tool shank 12 have to be appropriately designed so as to be able to threadingly engage the externally threaded surface of the coupling bar.

Attention is now drawn to Fig. 4 showing a partially sectioned exploded side view of a third embodiment of the cutting tool assembly 10 of the present invention. In accordance with the third embodiment the first coupling member is a securing screw 72 and the second coupling member is a locking recess 74. The tool shank 12 has a threaded through bore 78 passing through a section of the tool shank, the threaded through bore 78 extends from a side opening 80 in the tool shank to the elongated hole 28. The side opening 80 can be located at any point rearward of the forward end 14 of the tool shank, but it is preferably located adjacent the rear end 16 of the tool shank 12. The elongated support bar 18 is removably retained in the elongated hole 28 of the tool shank 12 by the securing screw 72 which is threadingly engaged with the threaded through bore 78 and which engages the locking recess 74 in the elongated support bar 18.

If desired, the elongated support bar 18 is provided with a coolant channel 84 for conducting a coolant fluid, the coolant channel extending axially from the rear end 36 of the elongated support bar 18 to the threaded bore 38 in the forward end 34 of the elongated support bar 18. Further if desired, the cutting head 20 is provided with a coolant channel 86 extending through the rear threaded portion 48 thereof and exiting the cutting head at exit openings 88 formed in the

forward cutting portion **44** thereof.

The three embodiments described above all require internal threading of the tool shank. However, as mentioned above, for some applications it is desirable to fabricate the tool shank from cemented carbide such as Tungsten carbide. Due to the difficulty involved in forming an internal thread on a bore in a tool bar made of cemented carbide a different approach is used, as will be described below with reference to the embodiments shown in Figs. 5 and 6. However, it will be appreciated that the embodiments shown in Figs. 5 and 6 are not restricted to tool shanks made of solid carbide but can also be used for tool shanks made of other materials.

Attention is now drawn to Fig. 5 showing a partially sectioned exploded side view of a fourth embodiment of the cutting tool assembly **10** of the present invention. As with the embodiments described above, the elongated support bar **18** is removably retained in a tool shank **12** and the cutting head **20** is removably retained in the elongated support bar **18**. In accordance with the fourth embodiment, the cutting tool assembly has a tool shank **12** with an elongated hole **28** extending axially between the forward and rear ends thereof. The elongated hole **28** comprises two portions, a forward portion **62** and a rear portion **64**. The forward portion **62** has a conical portion **30** adjacent the forward end **14** of the tool shank **12** and a cylindrical portion **68** extending rearwardly from the conical portion **30**. The rear portion **64** of the elongated hole **28** is cylindrical in shape and has a diameter that is preferably larger than the diameter of the cylindrical portion **68** of the forward portion **62**.

The cutting tool assembly **10** shown in Fig. 5 further comprises a cylindrical sleeve **94** having a non-threaded external cylindrical surface **96** and an axially extending threaded through bore **98**. The cylindrical sleeve **94** is made of a material such as steel in which the threaded through bore **98** can be made without difficulty. The cylindrical sleeve **94** can be retainably mounted in the rear portion **64** of the tool shank **12** either by soldering or by known heat shrink-fit techniques.

-12-

If soldering is used, the diameter of the cylindrical sleeve **94** should be smaller than the diameter of the rear portion **64** of the elongated hole **28** by, for example, approximately one tenth of a millimeter. If a heat shrink-fit technique is used then the diameter of the cylindrical sleeve **94** should be larger than the diameter of the rear portion **64** of the elongated hole **28** by, for example, a few hundredths of a millimeter. In general terms, a heat shrink-fit technique applied to the present embodiment would involve heating the rear portion **64** of the tool shank **12** until it expands sufficiently to enable the insertion of the cylindrical sleeve **94**. The rear portion **64** of the tool shank **12** is then cooled and cylindrical sleeve **94** becomes firmly mounted therein.

After the cylindrical sleeve **94** has been mounted in the rear portion **64** of the elongated hole **28** the elongated support bar **18** can be removably retained in the elongated hole **28** by threadingly engaging the externally threaded portion **42** of the elongated support bar **18** with the threaded through bore **98** of the cylindrical sleeve. The threaded through bore **98** forms a first coupling member of the cutting tool assembly **10**, whereas the externally threaded portion **42** of the elongated support bar **18** constitutes a second coupling member of the cutting tool assembly **10**. It will be apparent that once the cylindrical sleeve **94** has been mounted in the rear portion **64** of the elongated hole **28**, the resulting tool shank **12** of the fourth embodiment is generally equivalent to the tool shank **12** of the first embodiment shown in Fig. 2.

Attention is now drawn to Fig. 6 showing a partially sectioned exploded side view of a fifth embodiment of the cutting tool assembly **10** of the present invention. In accordance with the fifth embodiment, the cutting tool assembly has a tool shank **12** with an elongated hole **28** extending axially between the forward and rear ends thereof. The elongated hole **28** comprises two portions, a forward portion **62** and a rear portion **64**. The forward portion **62** has a conical portion **30** adjacent the forward end **14** of the tool shank **12** and a cylindrical portion **68** extending rearwardly from the conical portion **30**. The rear portion **64** of the

elongated hole **28** is cylindrical in shape and has a diameter that is preferably larger than the diameter of the cylindrical portion **68** of the forward portion **62**.

As with the fourth embodiment of the present invention, the cutting tool assembly **10** in accordance with the fifth embodiment shown in Fig. 6 further comprises a cylindrical sleeve **94** having a non-threaded external cylindrical surface **96** and an axially extending threaded through bore **98**. The cylindrical sleeve **94** is made of a material such as steel in which the threaded through bore **98** can be made without difficulty. The cylindrical sleeve **94** can be retainably mounted in the rear portion **64** of the elongated hole **28** either by soldering or by heat shrink-fit techniques. If soldering is used, the diameter of the cylindrical sleeve **94** should be smaller than the diameter of the rear portion **64** of the elongated hole **28** by, for example, approximately one tenth of a millimeter. If a heat shrink-fit technique is used then the diameter of the cylindrical sleeve **94** should be larger than the diameter of the rear portion **64** of the elongated hole **28** by, for example, a few hundredths of a millimeter.

In accordance with the fifth embodiment, the cutting tool assembly **10** still further comprises a coupling bar **50** having the form of a bushing with a generally cylindrical shape and an axially extending through bore **52**. As with the second embodiment, shown in Fig. 3, the coupling bar **50** has an internally threaded portion **54** having the same thread and internal diameter as the threaded portion **32** of the elongated hole **28** of the tool shank of the first embodiment. Therefore, the internally threaded portion **54** of the coupling bar **50** is capable of threadingly engaging the externally threaded portion **42** of the elongated support bar **18**. As previously mentioned, the coupling bar **50** in accordance with the fifth embodiment has an externally threaded surface **56** covering the whole of the coupling bar **50**. This feature, of complete external threading, could also be used for the coupling bar **50** in accordance with the second embodiment.

In the assembled cutting tool assembly **10** in accordance with the fifth embodiment of the invention, the cylindrical sleeve **94** is mounted in the rear

portion 64 of the elongated hole 28 and the coupling bar 50 is removably retained in the cylindrical sleeve 94 with the externally threaded surface 56 of the coupling bar 50 in threaded engagement with the threaded through bore 98 of the cylindrical sleeve 94. The elongated support bar 18 is removably retained in the elongated
5 hole 28 of the tool shank 12 with the externally threaded portion 42 in threaded engagement with the internally threaded portion 54 of the coupling bar 50 and at least a section of the conical portion 40 of the elongated support bar 18 in abutment with the conical portion 30 of the elongated hole 28. The cutting head 20 is removably retained in the elongated support bar 18 with the rear threaded portion
10 48 in threaded engagement with the threaded bore 38 in the forward end of the support bar 18.

In both the second and fifth embodiments, the internal thread on the internally threaded portion 54 and the external thread on the externally threaded surface 56 have different lead angles. Typically, the lead angle of the internal
15 thread is greater than the lead angle of the external thread.

Although the present invention has been described to a certain degree of particularity, it should be understood that various alterations and modifications can be made without departing from the spirit or scope of the invention as hereinafter claimed.

CLAIMS:

1. A cutting tool assembly (10) comprising:

a tool shank (12) having a forward end (14), a rear end (16) and a longitudinal axis (A) passing through the forward and rear ends, an elongated hole (28) extending axially from the forward end (14) of the tool shank (12), adjacent the forward end (14) of the tool shank (12) the elongated hole (28) having a conical portion (30), the tool shank (12) having a first coupling member adjacent the rear end (16) thereof;

an elongated support bar (18) having a forward end (34) and a rear end (36), with a threaded bore (38) extending axially rearwardly from the forward end (34) of the elongated support bar (18), the elongated support bar (18) having a conical portion (40) rearward of the forward end (34) thereof, the elongated support bar (18) having a second coupling member adjacent the rear end (36) thereof, the elongated support bar (18) being removably retained in the elongated hole (28) of the tool shank (12) with the first coupling member coupled to the second coupling member and with at least a section of the conical portion (40) of the elongated support bar (18) being in abutment with the conical portion (30) of the elongated hole (28); and

a cutting head (20) having a forward cutting portion (44) and a rear threaded portion (48); the rear threaded portion (48) of the cutting head (20) being threadingly engaged with the threaded bore (38) in the forward end (34) of the elongated support bar (18).

2. The cutting tool assembly according to Claim 1, wherein the elongated hole (28) has a threaded portion (32) adjacent the rear end (16) thereof and wherein the elongated support bar (18) has an externally threaded portion (42) adjacent the rear end (36) thereof and wherein the elongated support bar (18) is removably retained in the elongated hole (28) of the tool shank (12) with the externally threaded portion (42) of the elongated support bar (18) threadingly engaged with the threaded portion (32) of the elongated hole (28), the threaded portion (32) of the elongated hole (28) forming the first coupling member and the externally threaded

portion (42) of the elongated support bar (18) forming the second coupling member.

3. The cutting tool assembly (10) according to Claim 2, further comprising a coupling bar (50) generally cylindrically shaped, at least a portion having an externally threaded surface (56) and having an axially extending through bore (52) with an internally threaded portion (54), wherein the elongated hole (28) has a threaded portion (32) adjacent the rear end (16) of the tool shank (12) and wherein the elongated support bar (18) has an externally threaded portion (42) adjacent the rear end (36) thereof and wherein the coupling bar (50) is removably retained in the elongated hole (28) of the tool shank (12) adjacent the rear end (16) thereof with the externally threaded surface (56) of the coupling bar (50) threadingly engaged with the threaded portion (32) of the elongated hole (28) and the elongated support bar (18) is removably retained in the elongated hole (28) with the externally threaded portion (42) of the elongated support bar (18) threadingly engaged with the internally threaded portion (54) of the coupling bar (50), the internally threaded portion (54) of the coupling bar (50) forming the first coupling member and the externally threaded portion (42) of the elongated support bar (18) forming the second coupling member.

4. The cutting tool assembly (10) according to Claim 1, wherein the cutting tool assembly (10) further comprises a cylindrical sleeve (94) having a non-threaded external cylindrical surface (96) and an axially extending threaded through bore (98) and wherein the elongated hole (28) in the tool shank (12) has a cylindrically shaped rear portion (64) in which the cylindrical sleeve is mounted and wherein the elongated support bar (18) is removably retained in the elongated hole (28) with the externally threaded portion (42) of the elongated support bar (18) in threaded engagement with the threaded through bore (98) in the cylindrical sleeve (94), the threaded through bore (98) in the cylindrical sleeve (94) forming the first coupling member and the externally threaded portion (42) of the elongated support bar (18) forming the second coupling member.

5. The cutting tool assembly (10) according to Claim 1, wherein the

cutting tool assembly (10) further comprises a cylindrical sleeve (94) having a non-threaded external cylindrical surface (96) and an axially extending threaded through bore (98) and wherein the elongated hole (28) in the tool shank (12) has a cylindrically shaped rear portion (64) in which the cylindrical sleeve is mounted and wherein the cutting tool assembly (10) further comprises a coupling bar (50) generally cylindrically shaped, at least a portion of the coupling bar (50) having an externally threaded surface (56) and having an axially extending through bore (52) with an internally threaded portion (54), and the coupling bar (50) is removably retained in the cylindrical sleeve (94) with the externally threaded surface (56) of the coupling bar (50) in threaded engagement with the threaded through bore (98) of the cylindrical sleeve (94) and the elongated support bar (18) is removably retained in the elongated hole (28) of the tool shank (12) with the externally threaded portion (42) in threaded engagement with the internally threaded portion (54) of the coupling bar (50), the internally threaded portion (54) of the coupling bar (50) forming the first coupling member and the externally threaded portion (42) of the elongated support bar (18) forming the second coupling member.

6. The cutting tool assembly (10) according to Claim 1, wherein the tool shank (12) has a threaded through bore (78) passing through a section of the tool shank (12), the threaded through bore (78) extending from a side opening (80) in the tool shank (12) to the elongated hole (28), the elongated support bar (18) being removably retained in the elongated hole (28) of the tool shank (12) by a securing screw (72) threadingly retained in the threaded through bore (78), the securing screw (72) engaging a locking recess (74) formed in the elongated support bar (18), the securing screw (72) forming the first coupling member and the locking recess (74) of the elongated support bar (18) forming the second coupling member.

7. The cutting tool assembly (10) according to Claim 1, wherein the elongated support bar (18) is provided with a coolant channel (84) for conducting a coolant fluid, the coolant channel extending axially from the rear end (36) to the forward end (34) of the elongated support bar (18), and the cutting head (20) is provided with a coolant channel (86) extending through the rear threaded portion

(48) thereof and exiting the cutting head at exit openings (88) formed in the forward cutting portion (44) thereof.

8. The cutting tool assembly (10) according to Claims 4 or 5, wherein the tool shank (12) is made of cemented carbide.

5 9. The cutting tool assembly (10) according to Claim 8, wherein the cylindrical sleeve (94) is mounted in the tool shank (12) by a heat shrink-fit technique.

10. The cutting tool assembly (10) according to Claim 8, wherein the cylindrical sleeve (94) is mounted in the tool shank (12) by soldering.

10 11. The cutting tool assembly (10) according any one of the preceding claims, wherein the cutting head (20) is made of cemented carbide.

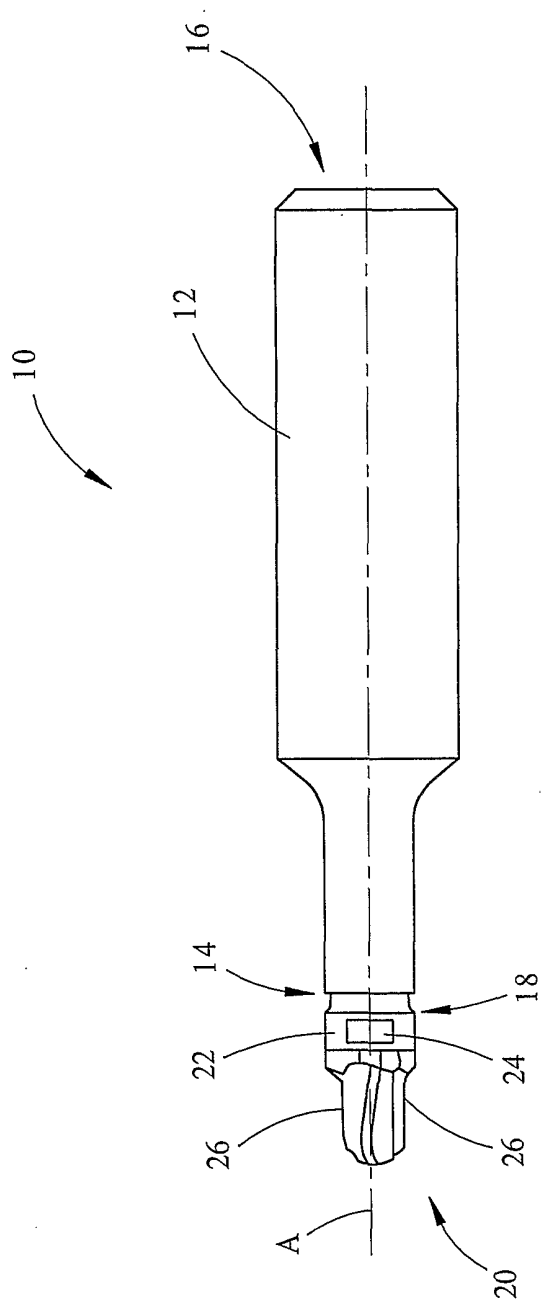

Fig. 1

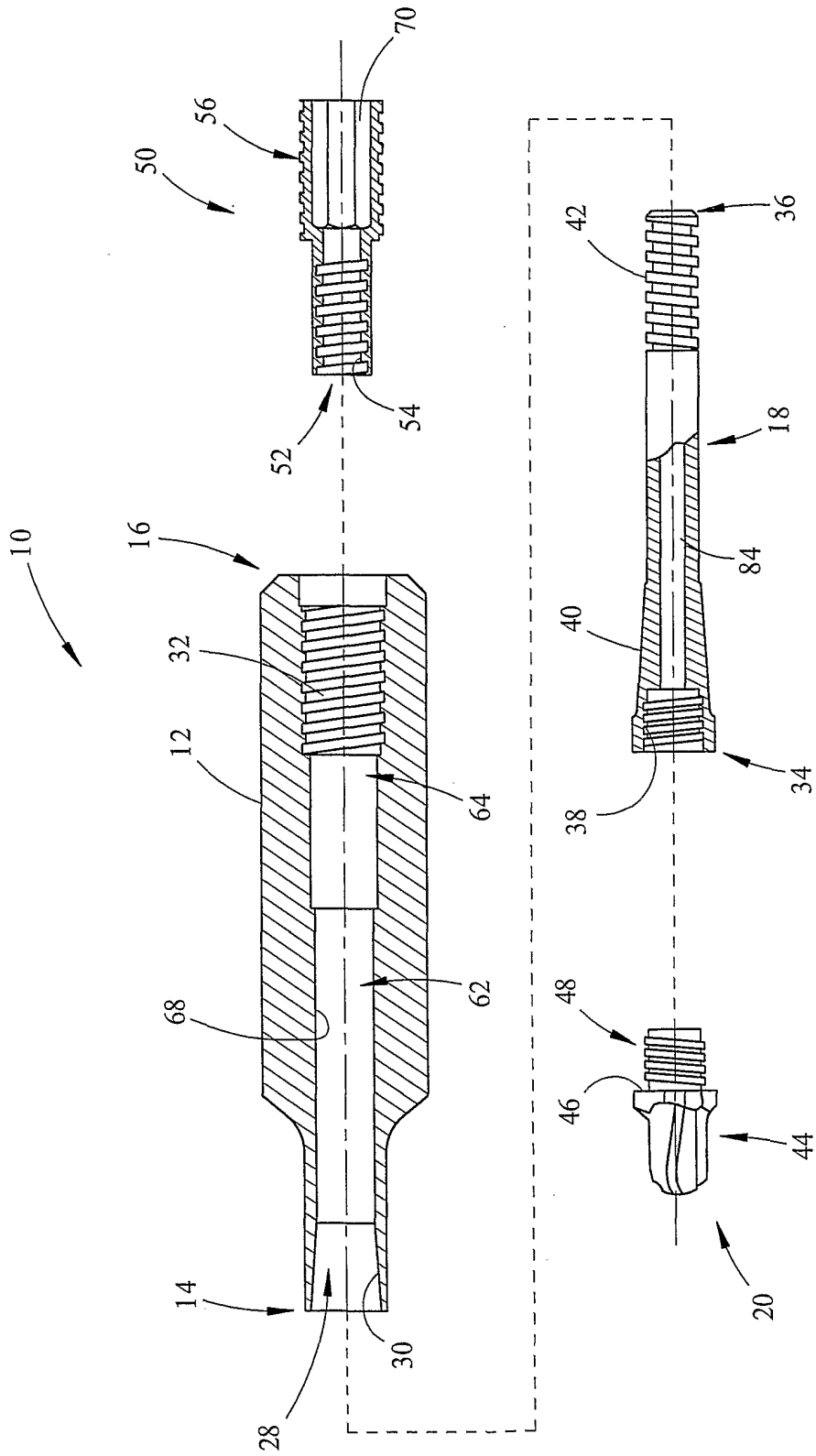

Fig. 3

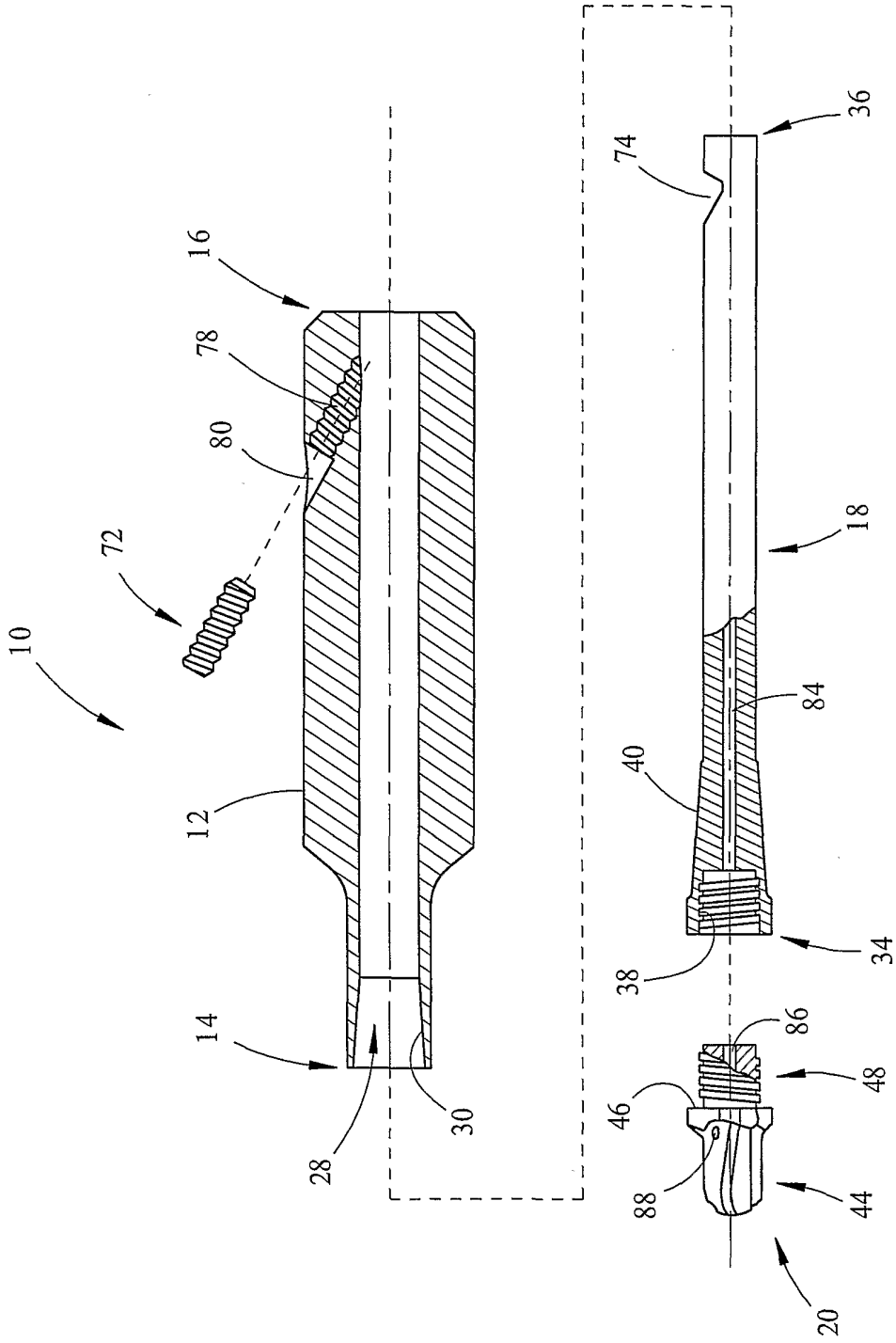

Fig. 4

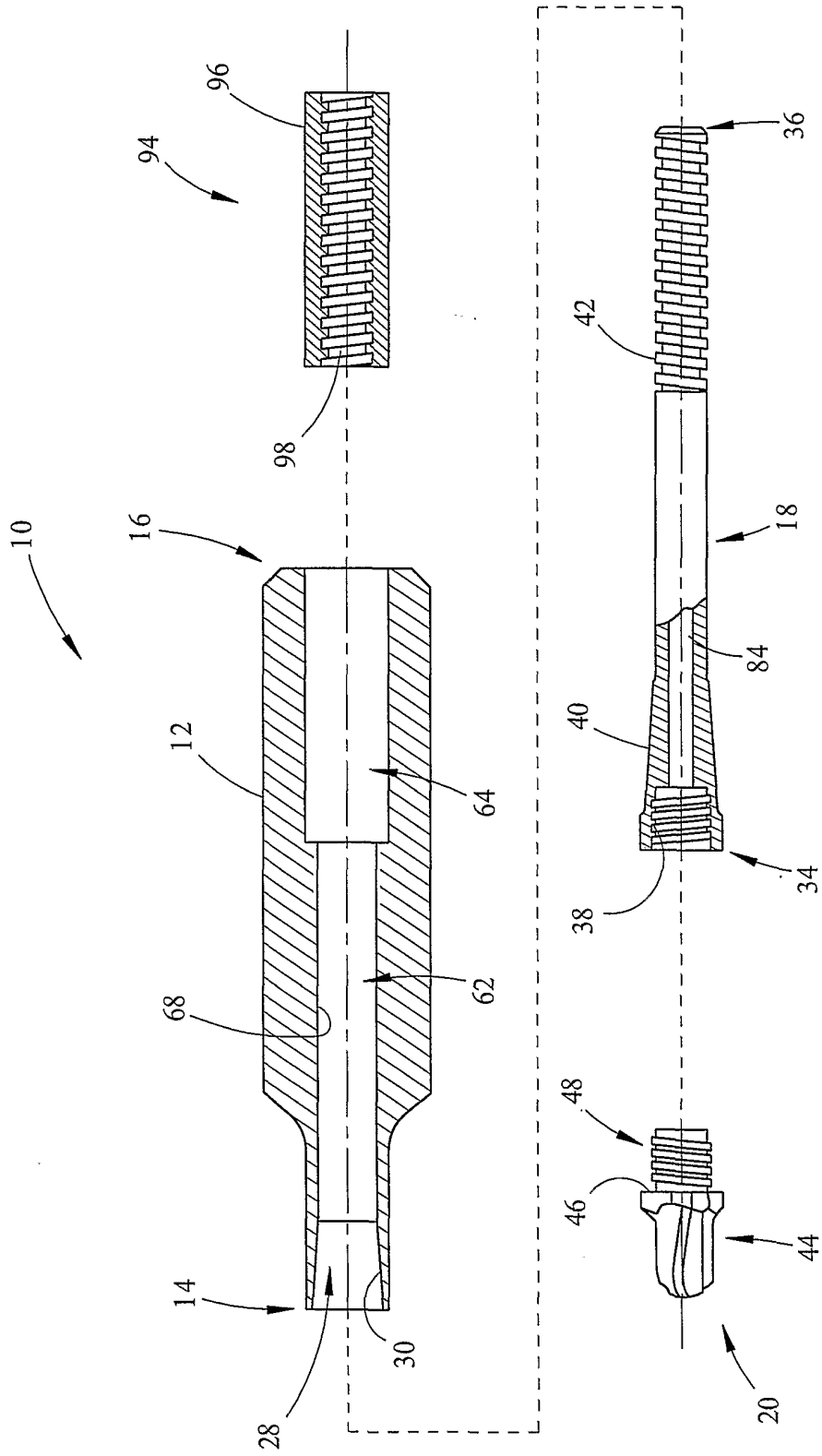

Fig. 5

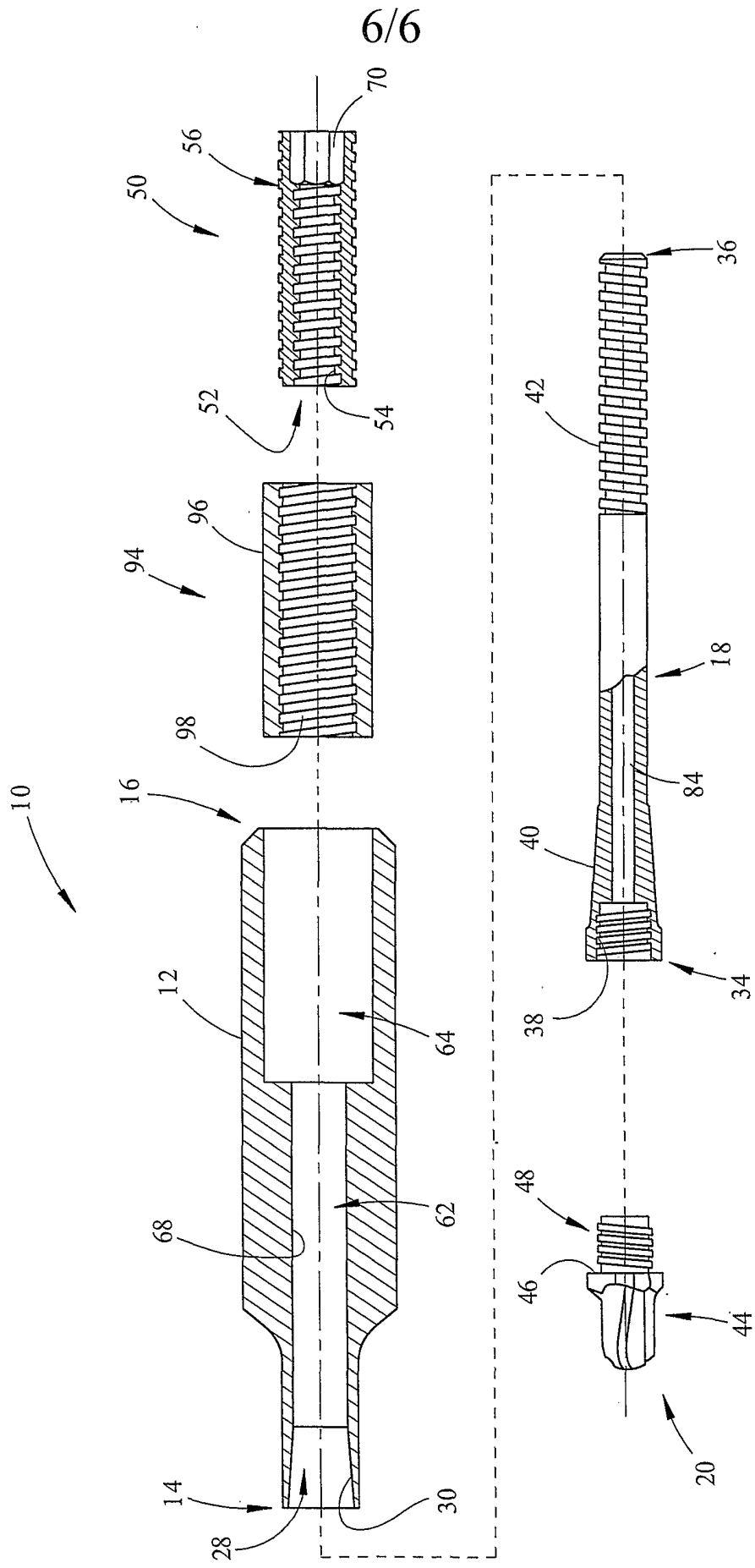

Fig. 6

INTERNATIONAL SEARCH REPORT

In International Application No
PCT/IL 01/00711

A. CLASSIFICATION OF SUBJECT MATTER
IPC 7 B23C5/10 B23B31/11

According to International Patent Classification (IPC) or to both national classification and IPC

B. FIELDS SEARCHED
Minimum documentation searched (classification system followed by classification symbols)
IPC 7 B23C B23B

Documentation searched other than minimum documentation to the extent that such documents are included in the fields searched

Electronic data base consulted during the international search (name of data base and, where practical, search terms used)

C. DOCUMENTS CONSIDERED TO BE RELEVANT

Category °	Citation of document, with indication, where appropriate, of the relevant passages	Relevant to claim No.
A	EP 0 776 719 A (SMOT) 4 June 1997 (1997-06-04) column 3, line 35 -column 4, line 49; figure 1	1-6, 11
A	US 5 899 642 A (BERGLÖW) 4 May 1999 (1999-05-04) column 2, line 27 -column 3, line 6; figures 1A,1B	1-6, 11
A,P	EP 1 029 620 A (NIKKEN) 23 August 2000 (2000-08-23) column 13, line 4 - line 42; figures 12-18C	7,8
A	US 6 053 670 A (SCHMID) 25 April 2000 (2000-04-25)	
	-/--	

Further documents are listed in the continuation of box C. Patent family members are listed in annex.

° Special categories of cited documents :

A document defining the general state of the art which is not considered to be of particular relevance

E earlier document but published on or after the international filing date

L document which may throw doubts on priority claim(s) or which is cited to establish the publication date of another citation or other special reason (as specified)

O document referring to an oral disclosure, use, exhibition or other means

P document published prior to the international filing date but later than the priority date claimed

T later document published after the international filing date or priority date and not in conflict with the application but cited to understand the principle or theory underlying the invention

X document of particular relevance; the claimed invention cannot be considered novel or cannot be considered to involve an inventive step when the document is taken alone

Y document of particular relevance; the claimed invention cannot be considered to involve an inventive step when the document is combined with one or more other such documents, such combination being obvious to a person skilled in the art.

* & * document member of the same patent family

Date of the actual completion of the international search 30 November 2001	Date of mailing of the international search report 06/12/2001
---	--

Name and mailing address of the ISA European Patent Office, P.B. 5818 Patentlaan 2 NL - 2280 HV Rijswijk Tel. (+31-70) 340-2040, Tx. 31 651 epo nl, Fax: (+31-70) 340-3016	Authorized officer Bogaert, F
--	--------------------------------------

INTERNATIONAL SEARCH REPORT

In ional Application No
PCT/IL 01/00711

C.(Continuation) DOCUMENTS CONSIDERED TO BE RELEVANT		
Category °	Citation of document, with indication, where appropriate, of the relevant passages	Relevant to claim No.
A	US 5 598 751 A (OCHAYON) 4 February 1997 (1997-02-04) -----	

INTERNATIONAL SEARCH REPORT

International Application No

PCT/IL 01/00711

Patent document cited in search report		Publication date	Patent family member(s)	Publication date
EP 776719	A	04-06-1997	FR 2741557 A1 EP 0776719 A1	30-05-1997 04-06-1997
US 5899642	A	04-05-1999	SE 509931 C2 CN 1231627 A EP 0929372 A1 JP 2001500801 T SE 9603525 A WO 9813161 A1	22-03-1999 13-10-1999 21-07-1999 23-01-2001 28-03-1998 02-04-1998
EP 1029620	A	23-08-2000	JP 3196170 B2 JP 2000233312 A JP 2001150221 A EP 1029620 A2	06-08-2001 29-08-2000 05-06-2001 23-08-2000
US 6053670	A	25-04-2000	EP 0911101 A1 EP 0911103 A1	28-04-1999 28-04-1999
US 5598751	A	04-02-1997	IL 106697 A CA 2117457 A1 DE 69401550 D1 DE 69401550 T2 DE 638384 T1 EP 0638384 A1 JP 7164234 A US 5496137 A ZA 9406085 A	16-10-1996 16-02-1995 06-03-1997 26-06-1997 28-09-1995 15-02-1995 27-06-1995 05-03-1996 17-03-1995