



Europäisches Patentamt
European Patent Office
Office européen des brevets



(11) **EP 0 896 861 A3**

(12) **EUROPEAN PATENT APPLICATION**

(88) Date of publication A3:
15.11.2000 Bulletin 2000/46

(51) Int. Cl.⁷: **B24D 5/12, B24D 7/18**
// B24B23/02

(43) Date of publication A2:
17.02.1999 Bulletin 1999/07

(21) Application number: **98660074.0**

(22) Date of filing: **06.08.1998**

(84) Designated Contracting States:
AT BE CH CY DE DK ES FI FR GB GR IE IT LI LU
MC NL PT SE
Designated Extension States:
AL LT LV MK RO SI

(72) Inventor: **Tanttu, Erkki**
37530 Säijä (FI)

(30) Priority: **11.08.1997 FI 973293**

(74) Representative:
Kuosmanen, Timo et al
Kolster Oy Ab,
P.O. Box 148,
Iso Roobertinkatu 23
00121 Helsinki (FI)

(71) Applicant:
T:mi Vaunutuoite Tanttu
37530 Säijä (FI)

(54) **Combined cutting and grinding tool**

(57) The invention relates to an arrangement in connection with a tool, to be used for instance in an angle grinder. The arrangement comprises a spindle (2) rotated by a drive unit, a standard wheel (1) being arranged to the spindle by means of a spindle nut (4). To the spindle (2) is also arranged a separate grinding member smaller than the standard wheel (1), the grind-

ing member having a grinding surface on its outer periphery. The arrangement can be used for instance in plumbing: the standard wheel (1) can be used for cutting the pipes and the grinding member for grinding the flash from the cutting point.

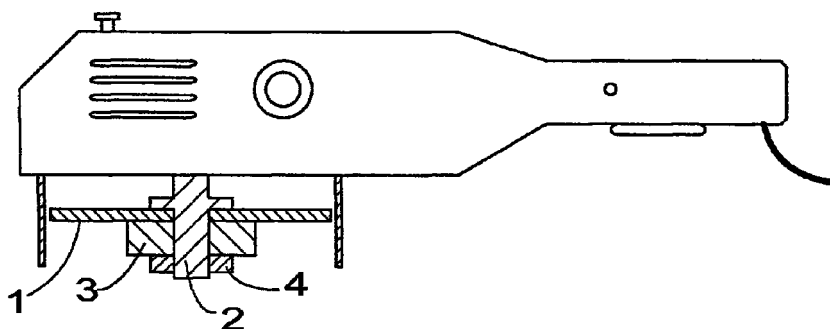

FIG. 1

EP 0 896 861 A3



European Patent
Office

EUROPEAN SEARCH REPORT

Application Number
EP 98 66 0074

| DOCUMENTS CONSIDERED TO BE RELEVANT | | | |
|---|--|--|--|
| Category | Citation of document with indication, where appropriate, of relevant passages | Relevant to claim | CLASSIFICATION OF THE APPLICATION (Int.Cl.6) |
| X | US 5 468 176 A (UDERT ET AL.) 21 November 1995 (1995-11-21) * column 3, line 64 - column 4, line 43; figure 3 * | 1 | B24D5/12 B24D7/18 //B24B23/02 |
| Y | ----- | 2-5 | |
| Y | US 1 883 392 A (MOLL) 18 October 1932 (1932-10-18) * page 2, line 45 - page 3, line 93; figures * | 2-5 | |
| X | EP 0 412 439 A (OREILLY GERARD) 13 February 1991 (1991-02-13) * abstract; figures * | 1 | |
| | | | TECHNICAL FIELDS SEARCHED (Int.Cl.6) |
| | | | B24B B24D |
| The present search report has been drawn up for all claims | | | |
| Place of search THE HAGUE | | Date of completion of the search 27 September 2000 | Examiner Garella, M |
| CATEGORY OF CITED DOCUMENTS | | | |
| X : particularly relevant if taken alone Y : particularly relevant if combined with another document of the same category A : technological background O : non-written disclosure P : intermediate document | | T : theory or principle underlying the invention E : earlier patent document, but published on, or after the filing date D : document cited in the application L : document cited for other reasons & : member of the same patent family, corresponding document | |

EPO FORM 1503 03.82 (P04C01)

**ANNEX TO THE EUROPEAN SEARCH REPORT
ON EUROPEAN PATENT APPLICATION NO.**

EP 98 66 0074

This annex lists the patent family members relating to the patent documents cited in the above-mentioned European search report. The members are as contained in the European Patent Office EDP file on
The European Patent Office is in no way liable for these particulars which are merely given for the purpose of information.

27-09-2000

| Patent document cited in search report | Publication date | Patent family member(s) | Publication date |
|--|------------------|-------------------------|------------------|
| US 5468176 A | 21-11-1995 | DE 4236964 A | 05-05-1994 |
| | | DE 59304670 D | 16-01-1997 |
| | | EP 0596831 A | 11-05-1994 |
| | | JP 6190730 A | 12-07-1994 |
| US 1883392 A | 18-10-1932 | NONE | |
| EP 0412439 A | 13-02-1991 | JP 3131468 A | 05-06-1991 |
| | | US 5020280 A | 04-06-1991 |