

J. T. Coxell,

Mangle,

N^o 26,227.

Patented Nov. 22, 1859.

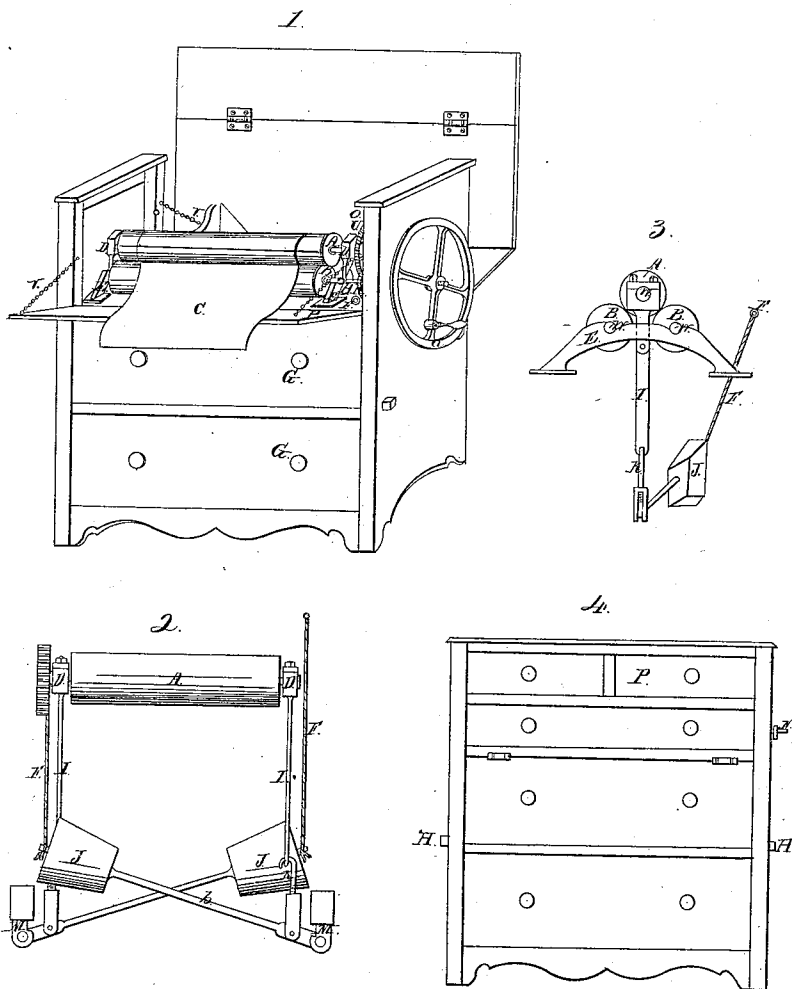

Witnesses:
Timothy Perry
Wm. A. Davis

Inventor:
James T. Coxell

UNITED STATES PATENT OFFICE.

JAS. T. COXELL, OF BROOKLYN, NEW YORK, ASSIGNOR TO HIMSELF AND EDWARD JONES,
OF SAME PLACE.

MANGLE.

Specification of Letters Patent No. 26,227, dated November 22, 1859.

To all whom it may concern:

Be it known that I, JAMES T. COXELL, of the city of Brooklyn, in the county of Kings and State of New York, have invented certain new and useful Improvements in Mangles; and I do hereby declare that the following is a full, clear, and exact description of the construction and operation of the same, reference being had to the annexed drawings, making a part of this specification, in which—

Figure 1, is a perspective view of the machine when in operation. Fig. 2, shows the method of attaching the weights to the bearings and roller. Fig. 3, is an end view of the roller's weight and connections. Fig. 4, represents mangle closed up when not in use.

Fig. 1 represents top roller A, resting in block D, which may be raised any distance sufficient to receive linen, C, which passes over rollers B B under and around roller A. The linen, after being mangled may be withdrawn and folded by reversing fly wheel Q. This machine therefore not only mangles the cloth, but folds it after the mangling operation is completed, delivering it upon the table in a neat and beautiful manner, evenly compacted and ready for transportation. E, is a bearing for rollers, B B. K, is a pinion on shaft N. S, is a cog-wheel fastened on shaft to roller, A. F, is a ring that lifts the weight, J, from roller A, to hook O, which permits linen with buttons or rings to pass through without injury. P, is a flap supported by chains V, V, which forms folding table. G G is case of mangles, representing drawer fronts. H, is a handle for carrying.

Fig. 2 represents the mode of attaching weights J J to bearings M M, which are secured to frame of case. It also shows the mode of connecting roller A, with weights

J J, by means of blocks D D, slides I I; and hooks K K with levers L L to which the weights J J are attached. Also chain F, by means of which the weights J J are lifted, thereby taking the pressure from roller A, to allow buttons, rings or other hard or uneven substances to pass between rollers A and B B (the latter not shown in this figure).

Fig. 3 represents the end of rollers A, and B B, upon bearing E, by means of journals W W; also slide I, and hook K connecting with lever L, and weight J, as described in Fig. 2.

Fig. 4 represents mangles closed up when not in use, with end of shaft N, on which flywheel Q is placed when in use; also handle H for carrying.

I do not claim the use of rollers for mangling, nor do I claim the weights suspended from rollers. But

Having thus described my invention, what I claim and desire to secure by Letters Patent is:

1. The arrangement of the rollers A, B, B, above the table so that the fabric will be folded by the machine, substantially as herein shown and described.

2. The combination with the weighted levers L of the lifting ropes F, or their equivalents, so that the downward pressure of the roller A may be released and the roller lifted, at the will of the operator, to allow such portions of the linen that have buttons or other elevations, to pass through the machine uninjured, all as herein shown and described.

JAMES T. COXELL.

Witnesses:

TIMOTHY PERRY,
FREDK. BEVIS.