

(12) INTERNATIONAL APPLICATION PUBLISHED UNDER THE PATENT COOPERATION TREATY (PCT)

(19) World Intellectual Property Organization  
International Bureau



(43) International Publication Date  
10 July 2003 (10.07.2003)

PCT

(10) International Publication Number  
**WO 03/055790 A1**

(51) International Patent Classification<sup>7</sup>: **B81C 1/00**,  
B81B 1/00, B32B 31/14

[SE/SE]; Enstavägen 33, S-187 35 Täby (SE). **LUND-  
BLADH, Lars** [SE/SE]; Gökärtsvägen 63, S-187 51 Täby  
(SE). **LARSSON, Olle** [SE/SE]; Ruddammsvägen 35A,  
S-114 21 Stockholm (SE).

(21) International Application Number: PCT/SE02/02431

(22) International Filing Date:  
19 December 2002 (19.12.2002)

(74) Agent: **BERGANDER, Håkan**; Gyros AB, Uppsala Sci-  
ence Park, S-751 83 Uppsala (SE).

(25) Filing Language: English

(81) Designated States (*national*): AU, CA, JP, US.

(26) Publication Language: English

(30) Priority Data:  
0104460-1 31 December 2001 (31.12.2001) SE  
60/369,714 4 April 2002 (04.04.2002) US

(84) Designated States (*regional*): European patent (AT, BE,  
BG, CH, CY, CZ, DE, DK, EE, ES, FI, FR, GB, GR, IE, IT,  
LU, MC, NL, PT, SE, SI, SK, TR).

(71) Applicant (*for all designated States except US*): **GYROS  
AB** [SE/SE]; Uppsala Science Park, S-751 83 Uppsala  
(SE).

Published:  
— with international search report

(72) Inventors; and

*For two-letter codes and other abbreviations, refer to the "Guid-  
ance Notes on Codes and Abbreviations" appearing at the begin-  
ning of each regular issue of the PCT Gazette.*

(75) Inventors/Applicants (*for US only*): **DERAND, Helene**

(54) Title: A MICROFLUIDIC DEVICE AND ITS MANUFACTURE

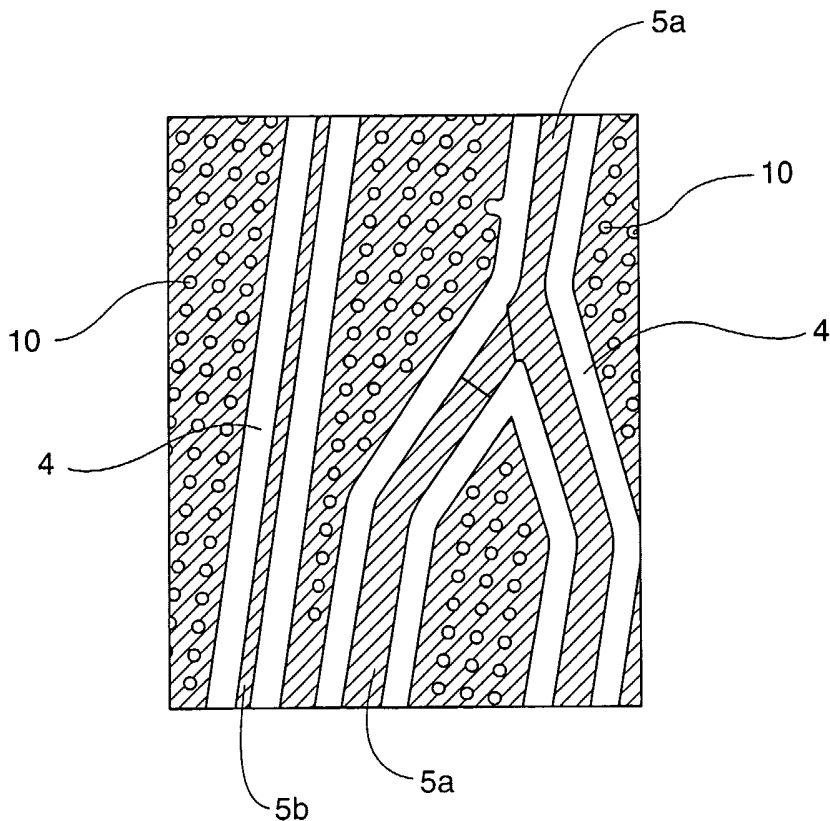

(57) Abstract: A method for increasing the yield of functional micro channel structures per microfluidic device in the manufacturing of microfluidic devices each of which comprises a plurality of enclosed micro channel structures, said manufacturing comprising joining a substrate surface I of a first generally planar plastic substrate I to a substrate surface II of a second generally planar substrate II via a bonding material. The characterizing steps are : (i) providing (a) substrate I in a form in which substrate surface I comprises a first relief pattern which defines at least a part of the walls of the enclosed micro channel structures, (b) substrate II in a form in which substrate surface II (1) has a size that enables coverage of said first relief pattern, and (2) optionally comprises a complementing relief pattern, (ii) apposing substrates surface I and substrate surface II so that enclosed micro channel structures are formed, (iii) bonding the substrate surfaces together via said relief patterns and said bonding



WO 03/055790 A1  
material.

**A MICROFLUIDIC DEVICE AND ITS MANUFACTURE.**

The present invention claims priority to SE-0104460-1, which was filed on December 31, 2001, and to U.S. provisional application S.N. 60/369,174, which was filed April 4, 2002.

**Technical Field**

The present invention concerns in a first aspect a method for the manufacture of a microfluidic device, which comprises a plurality of enclosed micro channel structures. The method comprises joining a substrate surface I of a first generally planar substrate I to a substrate surface II of a second generally planar substrate II via a bonding material. At least one of the substrates exposes a plastic material in the surface to be joined with the other substrate, which preferably also exposes a plastic material in the surface that is used for the joining. Each of surface I and surface II comprises structural parts that together define enclosed micro channel structures when the two substrate surfaces are mated to each other.

The invention also concerns in a second aspect a microfluidic device, which can be manufactured by the innovative method as well as by other methods. In this aspect each of one or more of the micro channel structures of the device may be loaded with a liquid aliquot, preferably aqueous, that will be transported within the device.

30

In the context of the invention, the term "microfluidic device" means a) a device that comprises a plurality of

enclosed micro channel structures, each of which comprises one or more enclosed micro channels and/or micro cavities, and b) that these micro channel structures shall be used for transporting and processing liquid aliquots that are in the microlitre range and may contain reactants including e.g. analytes and reagents. The liquid aliquots are typically aqueous. The transporting and processing are typically part of an analytically and/or a preparative process protocol. The number of micro channel structures in a device may be  $\geq 5$ , such as  $\geq 10$  or  $\geq 50$  and are typically  $\leq 1000$ , such as  $\leq 500$ . The term "microlitre range" means liquid aliquots  $\leq 1000 \mu\text{l}$ , i.e. the range includes the nanolitre range ( $\leq 1000 \text{ nl}$ ) as well as the picolitre range ( $\leq 1000 \text{ pl}$ ). The micro channel structures typically comprise micro channels with depths and/or widths that are  $\leq 1,000 \mu\text{m}$ , such as  $\leq 500 \mu\text{m}$  or  $\leq 200 \mu\text{m}$  or  $\leq 100 \mu\text{m}$  or  $\leq 50 \mu\text{m}$ . In addition to micro channels for transport of liquids there may also be separate channels that vent to ambient atmosphere, either for inlet or outlet of air. The widths and/or depths of venting channels may be in the same range as the other channels, but many times it may be advantageous to make them more narrow and/or more shallow than the channels used for liquid transportation (e.g. with width and/or depths  $\leq 500 \mu\text{m}$  or  $\leq 200 \mu\text{m}$  or  $\leq 100 \mu\text{m}$  or  $\leq 50 \mu\text{m}$ ).

This kind of devices typically is disc-like, preferably with an axis of symmetry ( $C_n$  where  $n$  is an integer 2, 3, 4, 5, 6 . . .  $\infty$ ) perpendicular to the plane of the disc. Disc-like microfluidic devices having this symmetry feature may have rectangular shape, such as squaric shape, and

other polygonal shapes for which this symmetry apply. A certain variant is the circular format  $(n = \infty)$ . In particular disc-like devices of the types mentioned may be spun around the axis of symmetry in order to transport liquids within the micro channel structures by the use of centrifugal force. The spin axis does not need to coincide with the axis of symmetry and may or may not intersect the disc plane. The liquid aliquots are typically aqueous and thus include water and mixtures of water with water-miscible organic solvents.

Microfluidic devices may have micro channel structures in one or more planes. The present invention concerns the formation of micro channel structures in a plane that corresponds to the interface between two apposing generally planar substrates. This does not exclude that the final device also may have one, two or more micro channel structures in other planes that may be placed above, below or at a certain angle in relation to the plane defined by the interface created in the present innovative method. These other micro channel structures may also be defined between two generally planar substrates that have been joined together. Micro channel structures that are present in different planes may form a completed micro channel structure in which a complete process protocol can be performed.

Micro channel structures may communicate with each other, both within a plane and between different planes. This communication may be via transport channels for liquids. There may also be venting channels for inlet of ambient atmosphere or for outlet to ambient atmosphere of air displaced by liquids during operation of the device.

Venting channels may be common for several micro channels through which liquid aliquots are to be transported

**Problems to be solved and objects of the invention.**

5 The kind of microfluidic devices defined above has previously been suggested for use as microlaboratories in which a plurality of similar analytical and/or preparative protocols that are in miniaturised form are carried out in parallel (one run per micro channel structure). When going  
10 down in channel sizes and liquid volumes, the demands on channel uniformity between different micro channel structures becomes extremely stringent in order to obtain reliable, reproducible and accurate results from the protocols.

15

We have recognized that the conventional methods of the type described in the first paragraph under the heading "Technical Field" easily cause bonding material, in particular adhesives, to spread into the micro channels in  
20 an uncontrolled manner when the substrates are pressed together during the actual bonding process. The risk for creation of irregularly occurring constrictions and/or complete clogging of a micro channel structure is significant and increases with amount of bonding material,  
25 in particular liquid adhesives, and contact area between the two substrates. A first object of the invention thus aims at minimizing this kind of risks.

A second object is to increase the yield of functioning  
30 micro channel structures in microfluidic devices that comprise a plurality of micro channel structures, for instance 2, 3, 4, 5 or more micro channel structures. The yield in this context typically means that  $\geq 70\%$ , such as  $\geq$

85% or  $\geq$  95% or 100% of the micro channel structures in the final microfluidic device are functional, i.e. that they permit through flow of a liquid by having no substantial constriction and/or clogging caused by uncontrolled spreading of bonding material during the manufacturing step comprising bonding of the surfaces to each other. This object in particular applies in case the micro channel structures comprise parts in which the widths and/or depths are in the lower part of the largest of the ranges given above.

By applying an adhesive to one of the surfaces that are to be joined together there will be certain drawbacks. The adhesive will appear also on parts of the inner surfaces of the micro channel structures. This is mostly not desirable and may require post-modification of the inner surfaces. A simple method for avoiding this kind of drawback is desirable. A third object of the invention aims at minimizing this drawback.

20

#### **Background publications.**

The manufacturing of microfluidic devices by bonding the surfaces of two generally planar substrates together as discussed under the heading "Technical Field" has been described in a number of publications.

US 5376252 (Ekström et al) vaguely suggests in general ~~terms that certain combinations of material might require~~ gluing for joining the substrates together. In certain variants, walls projecting from the surface of the plastic substrate defined the open micro channel structure. The problems with clogging and the formation of irregularly occurring constrictions were never recognized.

US 4957582 (Columbus) suggests to produce a microfluidic device comprising hydrophilic micro channels by using hydrophilic glues.

5

WO 9424900 (Öhman) suggests to use a gluing solution comprising (a) a solvent not dissolving the substrate surfaces, and (b) a gluing component capable of fusing with the substrate surfaces.

10

WO 9845693 and US 6176962 (Soane et al) suggest to use adhesives in combination with particular protocols.

WO 9956954 (Quine) suggests bonding together two generally  
15 planar plastic substrates that has been apposed. Bonding is accomplished by heating one of the apposing substrate surfaces above its transition temperature without reaching the transition temperature of the other apposing substrate surface. The "non"-heated surface comprises microscale  
20 grooves that defines the stretches of the final micro channel structures. A heat-sensitive meltable texture of bonding material elevating from one of the surfaces could be present outside the grooves.

25 WO 0050871 (Dapprich) presents microfluidic devices that may be manufactured by adhering the surfaces of two essentially planar substrates to each other. One of the substrates has a microstructured surface that defines the micro channel structures of the final device.

30

WO 0154810 (Derand et al) suggests to thermolaminate a plastic cover to open micro channel structures that are

manufactured in a plastic substrate and contain areas of different surface characteristics.

One important and common goal of WO 9424900, WO 9845693  
5 (and US 6176962), WO 9956954, WO 0154810, and US 4957582 is to minimise irregular deformation of the micro channels caused by intrusion of bonding material or by heat deformation of the channel structures. None of publications account for utilizing channel walls (including rims) that  
10 project from the surface of a substrate to minimize the risk for intrusion of bonding material.

WO 9832535 (Lindberg et al) and WO 0197974 (Chazan et al) concern the problem of minimizing the negative effect of  
15 bond void when bonding two planar substrates together. Bond voids depends on irregularities in the surfaces, contaminating particles, unevenly applied pressure during the actual bonding step etc. Bond voids are primarily a problem when rigid substrate materials, such as glass,  
20 silicon, quartz, diamonds and certain plastics that have a pronounced rigidity, are combined with bonding processes not utilizing adhesives. The problem with bond voids is normally not at hand for plastic substrates, which typically are flexible. WO 9832535 (Lindberg et al)  
25 suggests that bond voids can be avoided if the walls of the micro channels are defined by projections in the surface of the substrate and if there are also separate projections defining spacing posts. WO 0197794 (Chazan et al) suggests that the disturbing effect of bond voids is avoided by  
30 including venting elements in the substrate surfaces in order to neutralize the disturbing effects bond voids might have on the microfluidic channels.



WO 0130490 (Schaevitz et al) describes improved sealings of openings in a microfluidic device comprising a number of micro channel structures. Each opening has a collar to which a lid is sealed. The lids are conformable and/or adhesive.

### Figures

Figures 1a, b and c illustrate a micro channels structure of the innovative microfluidic device with a transparent substrate and without spacer elements. Figure 1a is a top view, figure 1b a cross-sectional view along A-A (exaggerated), and figure 1c illustrates typical dimensions in  $\mu\text{m}$ .

Figure 2 illustrates a similar micro channel structure as in figures 1a-c with thicker walls.

Figure 3 illustrates a micro channel structure of the innovative microfluidic device with separate spacer elements.

Figures 4a and b illustrate a comparison between micro channel structures in a device produced according to the background technology (figure 4a) and according to the instant innovative method (figure 4b).

### 25 The invention.

We have recognized that the objects of the invention can be achieved in case the walls (4) of the micro channel structures (5) are defined by a first relief pattern (4') projecting from a base surface I (3) of substrate surface I (2) and/or from a base surface II (9) of substrate surface II (8). We have also recognized that the micro channel structures (5) may be stabilized if a second relief pattern (10') corresponding to spacer elements (so called distance

holders) (10) are present in those parts of substrate surface I and/or substrate surface II that are not becoming part of a final micro channel structure. In other words the distance holders deriving from the second relief pattern  
5 are in the final microfluidic device located between individual micro channel structures. By selectively applying bonding material on the tops (6) of these relief patterns, we have minimized the risk for pressing bonding material, in particular adhesives, into the micro channels  
10 during the bonding process. Bond voids are in principle not formed meaning that the venting elements of WO 0197974 (Chazan et al) are not needed.

The term "selectively" in this context means that bonding  
15 material is applied to the top surfaces of at least the first relief pattern in substrate surface I and/or its complementary relief pattern (see below) in substrate surface II with essentially no bonding material distributed to parts of the surfaces that are to define inner surfaces  
20 of the micro channel structures to be formed. The term includes that parts of a substrate surface that are not part of the micro channel structures may be contaminated with bonding material.

25 The term "wall" in the context of the first relief pattern means side walls of the micro channels defined by this relief pattern, if not otherwise is apparent from the context. Top and bottom walls of the micro channel structures extend essentially in the same general direction  
30 as substrate surface I and II.

The first aspect of the invention is a method utilizing these findings. A preferred embodiment of the first aspect

thus is a method as defined in the first paragraph under the heading "Technical Field". The method is characterized in comprising the steps of

- (i) providing
    - 5 (a) substrate I (1) in a form in which substrate surface I (2) comprises a first relief pattern (4') (raised pattern) which defines at least a part of the 10 walls (4) of the micro channel structures (5), and
    - (b) substrate II (7) in a form in which substrate surface II (8) (1) has a size that enables coverage of said 15 first relief pattern (4'), and
    - (2) optionally comprises a complementing relief pattern comprising the remaining parts of the walls if the first relief pattern (4') is incomplete,
  - 20 (ii) apposing substrates surface I (2) and substrate surface II (8) so that the enclosed micro channel structures (5) defined by the first relief pattern (4') and, if 25 present, its complementing relief pattern, are formed,
  - (iii) applying conditions that will bond the surfaces together via said bonding material and via said relief pattern(s) without deforming said micro channel structures.
- 30 This aspect of the invention also concerns a method for minimizing the risks and/or to increase the yield per device of functioning micro channel structures intended for liquid flow as discussed under the heading "Problems to be

solved and objects of the invention" in the manufacturing method defined under the heading "Technical Field" and/or defined in the preamble of the independent method claim.

5 In preferred variants, substrate surface I (2) and/or substrate surface II (8) also may comprise a second relief pattern (10') (raised pattern) defining at least a part of the spacer elements (10) (distance holders) which have been discussed above. In the case the spacer elements are not  
10 completely defined by this second relief pattern, the remaining parts of them are defined by a complementing relief pattern in the other substrate surface. In a preferred variant in which there are spacer elements, the second relief pattern (10') is part of substrate surface I  
15 (2), i.e. the first and second relief patterns (4' and 10') are present in the same substrate surface.

It follows that the tops of each relief pattern that is present are used for the bonding.

20

In the most preferred variants, the first and second relief patterns define the walls (4) of the micro channel structures and the spacer elements (10) (if present), respectively, and are present in substrate surface I (2).  
25 There is thus no need in this embodiment for including complementing relief patterns as discussed above. The top planes defined by the tops of the first and second relief pattern are essentially planar and coincide. The walls of the micro channel structures in this embodiment typically  
30 correspond to rims delineating those parts of base surface I that constitute the "bottom" surfaces of the micro channel structures.

The invention will now be further described in relation to the figures where the same numerals are used for corresponding functional parts in the different figures.

5 As illustrated in figures 1a and b, figure 2 and figure 3, the final microfluidic device thus may comprise a first generally planar substrate I (1) comprising a first substrate surface I (2) with a distinct base surface I (3) from which the walls (4) (first relief pattern (4')) of a  
10 micro channel structure (5) project. The micro channel structure (5) comprises micro channels for transportation of liquids (5a) or for venting to ambient atmosphere (5b). Apposed to the tops (6) of the walls (4) there is a second generally planar substrate (7) that may be transparent as  
15 shown in the figures. The second substrate comprises a second substrate surface (II) (8) with a base surface II (9) which in the variant shown is devoid of relief pattern and coincides with and is indistinguishable from substrate surface II. The walls (4) of the micro channel structure  
20 (5) and possibly also separate spacer elements (10) (second relief pattern (10')) extend between the two base surfaces, which for the preferred variants illustrated in the figures extends from base surface I to substrate surface II.

25 The figures illustrate preferred variants in which the tops (6) of the first relief pattern (4') define a common essentially planar top plane. In the case substrate surface I (2) also comprises a second relief pattern (10') which defines the spacer elements (10), the tops of this second  
30 relief pattern preferably coincide with the common top plane defined by the tops of the walls (4) (first relief pattern (4')).

The walls (4) of micro channel structures and the separate spacer elements (10) are formed when a corresponding relief pattern elevating from a base surface of one of the substrates meets the substrate surface of the other substrate. In a general sense, a base surface (3 or 9) is thus a substrate surface (2 or 8) without a relief pattern and a substrate surface (2 or 8) is a base surface (3 or 9) with a superimposed relief pattern (if present).

10 The dimensions of the walls of the micro channels and the spacer elements and accordingly also the elevated parts of the relief patterns will depend on various factors. Factors to account for are material in the substrates, design of the individual micro channel structures, such as the width and the depth of the micro channel structures, etc. That the width of the walls of the micro channel may differ between channels as well as within channels is illustrated in the figures. If different parts of a micro channel are close to each other it is many times practical to merge the delineating walls into a common wall (11).

Typically, the width of at least a portion of the walls is  $\geq 1 \mu\text{m}$ , such as  $\geq 10 \mu\text{m}$ , and/or  $\leq 1000 \mu\text{m}$ , such as  $\leq 500 \mu\text{m}$ . For walls that are common for two neighboring micro channels these limits should be doubled.

The ratio between the width and the height of the wall is typically  $\geq 0.1$ , such as  $\geq 1$  or  $\geq 5$ .

30 The micro channels, the walls and the spacer elements, if present, occupy typically  $\leq 95\%$ , such as  $\leq 90\%$  or  $\leq 80\%$  or

$\leq 50\%$  or  $\leq 10\%$ , or  $\geq 1\%$ , such as  $\geq 5\%$ , of the smallest of substrate surfaces I and II.

The height of one or more spacer elements or of the walls  
5 of the micro channel structures is typically the same as the depth of at least a portion of an open micro channel structure. This rule primarily relates to devices and methods utilizing substrate surfaces obtained by replicating against a matrix comprising the inverse relief  
10 pattern.

The depth of a micro channel structure may vary within a micro channel structure.

15 The term "height" in the context of the invention refers to the height measured relative to the base surface outside a micro channel and in close proximity to the position for which the height is measured.

20 The term "width" refers to the width at the half height of a wall, if not otherwise indicated.

The final microfluidic device typically comprises 1, 2, 3, 4, 5 or more separate spacer elements per micro channel  
25 structure with an upper limit typically being 300 or more separate spacer elements per micro channel structure. A separate spacer element typically has a cross sectional area that is in the interval of  $1 \mu\text{m}^2$  -  $10 \text{mm}^2$ , such as  $10 \mu\text{m}^2$  -  $10 \text{mm}^2$  or  $100 \mu\text{m}^2$  -  $1 \text{mm}^2$ , at its smallest part and is  
30 physically separated from the walls of the micro channels and from the edges of the substrate surfaces. The cross-sectional area of a spacer element may be squaric,

triangular, rounded, elongated etc. The cross-sectional area and number of the spacer elements depend on factors such as the area of the substrate surfaces, number of micro channels structures, geometric arrangement of the spacer  
5 elements and/or the micro channel structures total, material of the substrates etc.

The substrates may be made from different materials, such as plastics including elastomers, such as rubbers including  
10 silicone rubbers (for instance poly dimethyl siloxane) etc. From the manufacturing point of view, substrate surfaces exposing a relief pattern in plastic material is many times preferred because the costs for plastics are normally low and mass production can easily be done, for instance by  
15 replication. Typical manufacturing processes involving plastic material are photolithography, laser ablation, replication by embossing, moulding, casting etc. For replication see for instance US 5376252 (Danielsson et al). At the priority date of this invention the preferred  
20 plastic materials were polymethyl methacrylate (PMMA), polycarbonates and other thermoplastic materials, e.g. plastic material based on monomers which consist of a polymerisable carbon-carbon double or triple bonds and saturated branched straight or cyclic alkyl and/or alkylene  
25 groups. Typical examples are Zeonex<sup>TM</sup> and Zeonor<sup>TM</sup> from Nippon Zeon, Japan. See for instance WO 0056808 (Larsson et al) which is hereby incorporated by reference.

Surfaces that are to define inner surfaces of micro channel  
30 structures may have been made hydrophilic in advance of step (i) or after step (iii). If in advance, one or both of the substrate surfaces provided in step (i) is/are of a suitable hydrophilicity, at least at those parts that will



define inner surfaces of micro channel structures after step (iii). Typical hydrophilization protocols are outlined in WO 0056808, WO 0147637, or US 5,773,488 (Gyros AB). The hydrophilicity (wettability) of inner surfaces 5 should be as given in these publications, i.e. an aqueous liquid, such as water, having a volume within any of the intervals given herein should be drawn by capillarity into one of the micro channel structures. Where appropriate hydrophobic surface breaks (e.g. as anti-wicking means 10 and/or valves) are preferably introduced before step (i) as outlined in WO 9958245 and WO 0274438. See also WO 0185602 (Åmic AB & Gyros AB). Hydrophobic surface breaks may also be introduced after step (iii).

15 The exact demand on hydrophilicity (wettability) of inner surfaces of a micro channel structure may vary between different functional units of a structure. Except for local hydrophobic surface breaks (hydrophobic = liquid contact angle  $> 90^\circ$ ), the liquid contact angle for at least two or 20 three inner walls of a micro conduit in a particular functional unit should be wettable (= hydrophilic = liquid contact angle  $\leq 90^\circ$ ) for the liquid to be transported, with preference for liquid contact angles that are  $\leq 60^\circ$ , such as  $\leq 50^\circ$  or  $\leq 40^\circ$  or  $\leq 30^\circ$  or  $\leq 20^\circ$ . In the case one or more 25 inner walls have a higher liquid contact angle, for instance is non-wettable (hydrophobic), this can be compensated by a lowered liquid contact angle on the other walls. This may be particularly important if one of surface I and II is hydrophobic. These figures for wettability in 30 most cases apply to one or more inner surfaces (bottom surface, top surface, side wall surfaces) throughout a

complete micro channel structure, except for valves and venting channels not intended for liquids.

The liquid contact angles given above refer to equilibrium contact angles and measured at the temperature of use, for instance room temperature such as  $+25^{\circ}\text{C} \pm 5^{\circ}\text{C}$ .

In preferred variants, substrate I is made in plastic material, for instance by the techniques referred to above. In the preferred variants substrate II is also made in plastic material.

The bonding material may be part of or separately applied to substrate surface I and/or substrate surface II. As illustrated in figure 1b the bonding material is preferably present on the tops of a relief pattern, for instance the tops of the first relief pattern and/or of the second relief pattern, if present, and/or on one or both of the complementing relief patterns. In this variant the bonding material should be placed selectively on tops of relief patterns and not on surface parts that will be within the final micro channels.

The bonding material may be the same plastic material as is present in a substrate surface, provided this plastic material can work as a bonding material. Other useful bonding materials are various kinds of adhesives which fit to the material exposed in the substrate surfaces and to the intended use of the final device. Typically adhesives may be selected amongst melt-adhesives, and curing adhesives etc. Illustrative examples of curing adhesives

are thermo-curing, moisture-curing, and bi-, three- and multi-component adhesives.

In principle the adhesive may be selected as outlined in US 5 6176962 and WO 9845693 (Soane et al) which are hereby incorporated by reference. Thus suitable bonding materials include elastomeric adhesive materials and curable bonding materials. These kinds of bonding material as well as others may be in liquid form when applied to a substrate 10 surface. Bonding materials including adhesives thus comprises liquid curable adhesive material and liquid elastomeric material. After application the adhesive material is rendered more viscous or non-flowable for instance by solvent removal or partial curing before the 15 other substrate is contacted with the adhesive. Liquid form includes material of low viscosity and material of high viscosity.

Curable adhesive includes polymerizable adhesives and 20 activatable adhesives.

At the priority date the invention seems to have its greatest advantage in case the bonding material was a curing adhesive selected amongst the kinds just mentioned.

25

As indicated above step (i) may comprise as a separate step application of the bonding material to substrate surface I and/or substrate surface II.

30 Step (ii) includes that any complementing relief pattern is matched to the corresponding relief pattern in the apposing surface, so that enclosed micro channel structures or complete spacer elements, respectively, are formed.

Step (iii) includes that bonding conditions are applied. The conditions are typically within ranges given by the manufacturer of the adhesive, with appropriate care taken  
5 not to deform the relief pattern defining the walls of the micro channel structures. See for instance WO 9424900 (Ove Öhman), WO 9845693 (and US 6176962) (oane et al), WO 9956954 (Quine), WO 0154810 (Dérاند), and US 4957582 (Columbus). Typically this step comprises pressing  
10 substrate surface I and substrate surface II together and applying the specific conditions required by a selected bonding material, for instance heat if it is a melt-adhesive, UV irradiation if it is a UV curing adhesive, moisture if it is a moisture-curing adhesive etc. In many  
15 cases heating may speed up the curing reaction.

#### EXPERIMENTAL PART

##### Example 1

20 This example illustrates the manufacture of a microfluidic device made of a polycarbonate disc (substrate I) with micro channel structures to which a lid (substrate II) made from polycarbonate was bonded using a photocurable bonding material. Walls projecting from a base surface of substrate  
25 I as illustrated in **figures 1a and b**, and **figure 2** defined the micro channel structures. Certain variants with spacer elements (**figure 3**) were also managed. The bonding material was photocurable. The figures show enclosed micro channels structures (5), walls (4) and spacers (10).

30

A thin layer (1-10  $\mu\text{m}$ ) of the bonding material (UVF 00006, Akzo Nobel Inks) was applied onto the structured disc (substrate I) using a flexoprinter for CD/DVD (Pinto,

Lyrec, Denmark). The lid (with inlet/outlet holes) (substrate II) was carefully positioned on top to form a closed structure. Curing of the bonding material was achieved using a UV lamp. As seen in **figures 1a and b**, **figure 2** and **figure 3** non-clogged enclosed microfluidic channels were formed. Water could be transported through the enclosed micro channel structures.

#### 10 **Example 2**

This example illustrates a comparison between the manufacture of a non-functioning microfluidic device according to the prior art technique (**figure 4a**) and of a functioning microfluidic device according to the invention **15 (figure 4b)**. Substrate I comprised open micro channel structures and was a polycarbonate disc. Substrate II was a lid made from polycarbonate. The bonding material was photocurable. **Figures 4a and b** show enclosed micro channel structures (5), walls (4, only in **figure 4b**) and spacer **20 elements (11, only in figure 4b)**.

A thin layer (1-10  $\mu\text{m}$ ) of the bonding material (UVF 00006, Akzo Nobel Inks) was applied onto the structured disc using a flexoprinter for CD/DVD (Pinto, Lyrec, Denmark). The lid **25 (with inlet/outlet holes)** was carefully positioned on top to form a closed structure. Curing of the bonding material was achieved using a UV lamp. Although the same procedure as in example 1 was used for applying adhesive onto this substrate, adhesive was found to flow into the channels and **30 plug them completely**, as seen in **figure 4a (12)**. We were not able to transport any water through these channels. As illustrated in **figure 4b**, the inventive method resulted in a lower risk for clogged micro channels.

## CLAIMS

1. A method for increasing the yield of functional micro channel structures per microfluidic device in the manufacturing of microfluidic devices each of which comprises a plurality of enclosed micro channel structures, said manufacturing comprising joining a substrate surface I of a first generally planar substrate I to a substrate surface II of a second generally planar substrate II via a bonding material, at least one of the substrate surfaces exposing a plastic material,
- characterized** in comprising the steps of
- (i) providing
- (a) substrate I in a form in which substrate surface I comprises a first relief pattern which defines at least a part of the walls of the enclosed micro channel structures,
- (b) substrate II in a form in which substrate surface II (1) has a size that enables coverage of said first relief pattern, and (2) optionally comprises a complementing relief pattern,
- (ii) apposing substrates surface I and substrate surface II so that enclosed micro channel structures are formed,
- (iii) bonding the substrate surfaces together via said relief patterns and said bonding material.

2. The method of claim 1, **characterized** in that A) one of the substrate surfaces comprises a second relief pattern defining at least a part of spacer elements that in the final microfluidic device are positioned between said enclosed micro channel structures, and B) the other  
5 substrate surface optionally contains a complementing relief pattern.
3. The method of any of claims 1-2, **characterized** in that  
10 said bonding material is present selectively on the tops of the first relief pattern and/or on the tops the second relief pattern, if present, and/or on the tops of complementing relief patterns, if present.
- 15 4. The method of any of claims 1-3, **characterized** in that  $\geq$  70% of the enclosed micro channel structures are functional.
5. The method of any of claims 1-4, **characterized** in that  
20 the microchannel structures comprise parts in which the width and/or depth is  $\leq$  200  $\mu\text{m}$ .
6. The method of any of claims 1-4, **characterized** in that  
25 the first and second relief patterns are on substrate surface I and have tops defining a common top plane.
7. The method of any of claims 1-6, **characterized** in that  
in the final microfluidic device the first relief  
pattern defines the complete walls of the enclosed micro  
30 channel structures and the second relief pattern, if  
present, defines the complete spacer elements.

8. The method of any of claims 1-7, **characterized** in that the first relief patterns are of the same material as the corresponding substrate surface, preferably as an integral part of substrate surface I.
- 5
9. The method of any of claims 1-8, **characterized** in that the bonding material is an adhesive.
10. The method of any of claims 1-9, **characterized** in that the widths (at the half height) of at least a portion of said walls are in the interval of 1 - 1000  $\mu\text{m}$ .
- 10
11. The method of any of claims 1-10 **characterized** in that the ratio between the width (at the half height) and the height of the wall (measured from the base surface) is  $\geq 0.1$ .
- 15
12. The method of any of claims 1-11, **characterized** in that the height of one or more of said spacer elements or said relief pattern is the same as the depth of at least a portion of an open micro channel structure.
- 20
13. The method of any of claims 1-12, **characterized** in that the depth of a micro channel structure varies within the structure.
- 25
14. A microfluidic device comprising a plurality of enclosed micro channel structures that are
- 30
- (a) embedded between substrate surface I of a first generally planar substrate I, and substrate surface II of a second generally planar



substrate II, at least one of said substrate  
surfaces

exposing a plastic material, and

(b) delineated by walls stretching between said

5 substrates,

said walls being joined to at least one of said two  
surfaces via a bonding material and being an integral  
part of a surface to which it is not joined via a  
10 bonding material.

15. The microfluidic device of claim 14,  
**characterized** in that separate spacer elements (a) are  
placed between said microchannel structures, (b) are  
15 joined to at least one of said two substrate surfaces  
via a bonding material and are an integral part of a  
substrate surface to which they are not joined via a  
bonding material.

20 16. The microfluidic device of any of claims 14-15,  
**characterized** in that said bonding material is  
selectively present where said walls and spacer  
elements, if present, join a substrate surface without  
being an integral part thereof.

25

17. The microfluidic device of any of claims 14-16,  
characterized in that  $\geq 70\%$  of the microfluidic  
structures are functional.

30 18. The microfluidic device of any of claims 14-17,  
**characterized** in that the microchannel structures

comprise parts in which the width and/or depth is  $\leq 200$   $\mu\text{m}$ .

19. The microfluidic device of any of claims 14-18,  
5 **characterized** in that said bonding material derives from  
an adhesive.

20. The microfluidic device of any of claims 14-19,  
**characterized** in that the widths (at the half height) of  
10 at least a portion of said walls are in the interval 1 -  
1000  $\mu\text{m}$ .

21. The microfluidic device of any of claims 14-20,  
**characterized** in that the ratio between the width (at  
15 the half height) and the height of the walls (measured  
from a base surface) is  $\geq 1$ .

22. The microfluidic device of any of claims 14-21,  
**characterized** in that the height of one or more of said  
20 spacer elements or said walls is the same as the depth  
of at least a portion of a micro channel structure.

23. The microfluidic device of any of claims 14-22,  
**characterized** in that the depth of a micro channel  
25 structure varies within the structure.

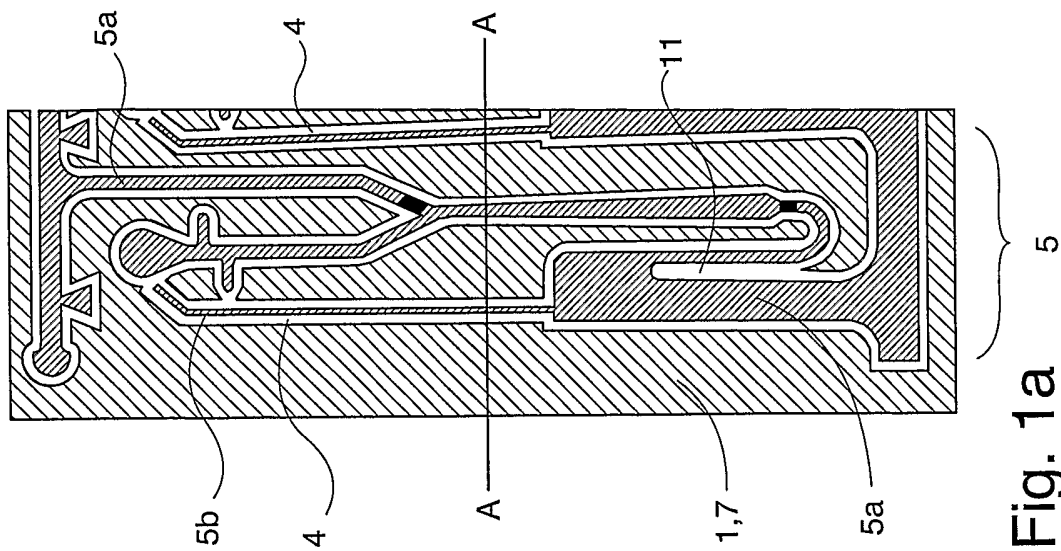

Fig. 1a

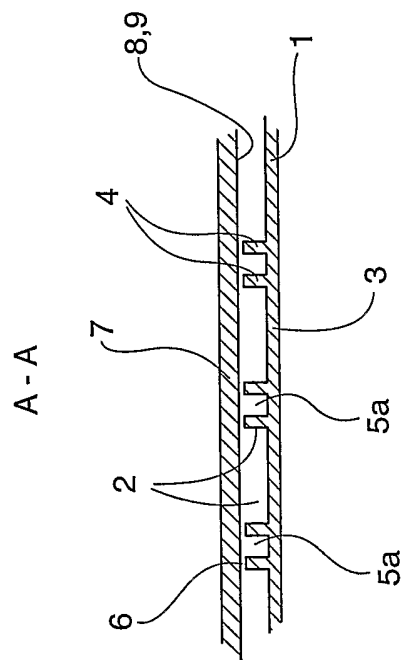
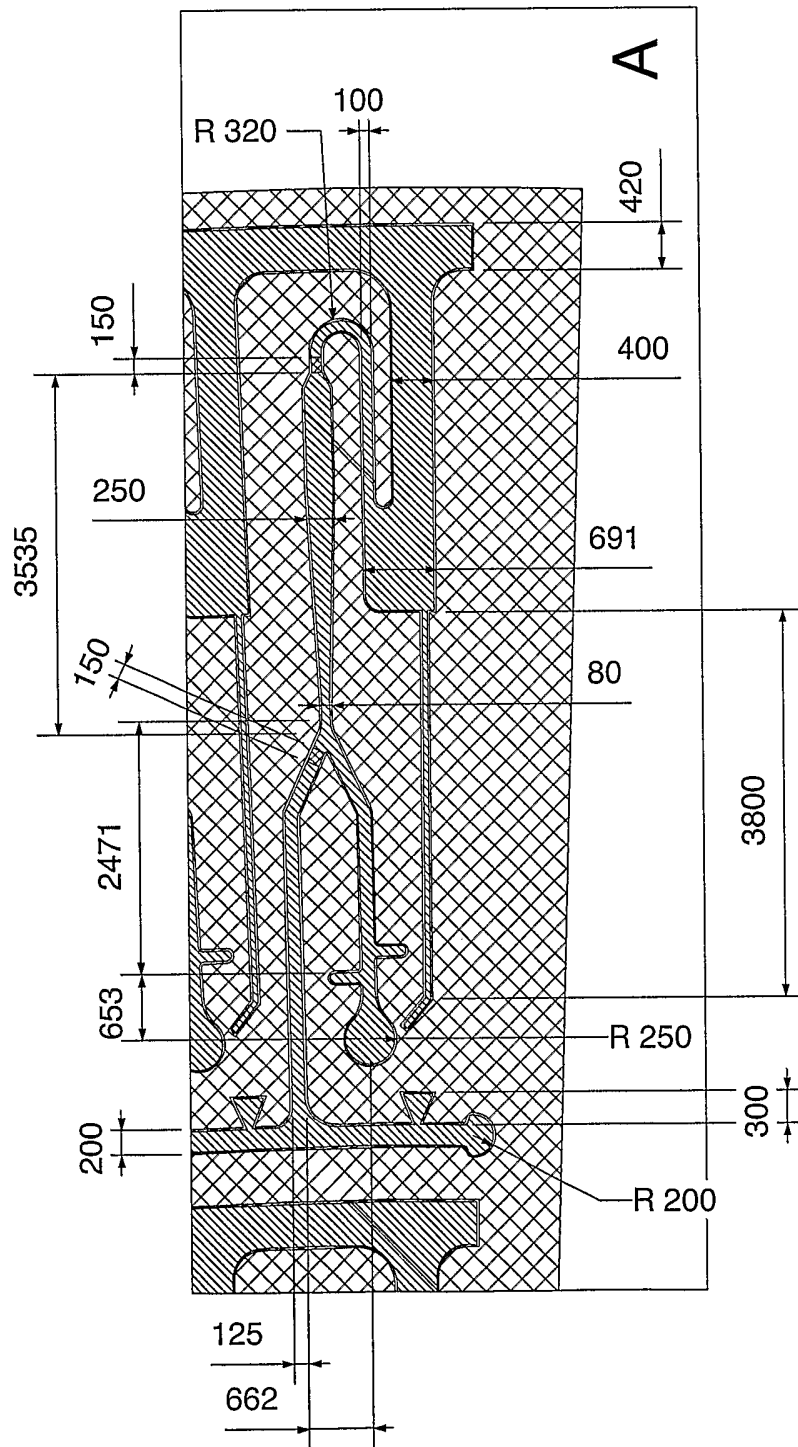

Fig. 1b

Fig. 1c



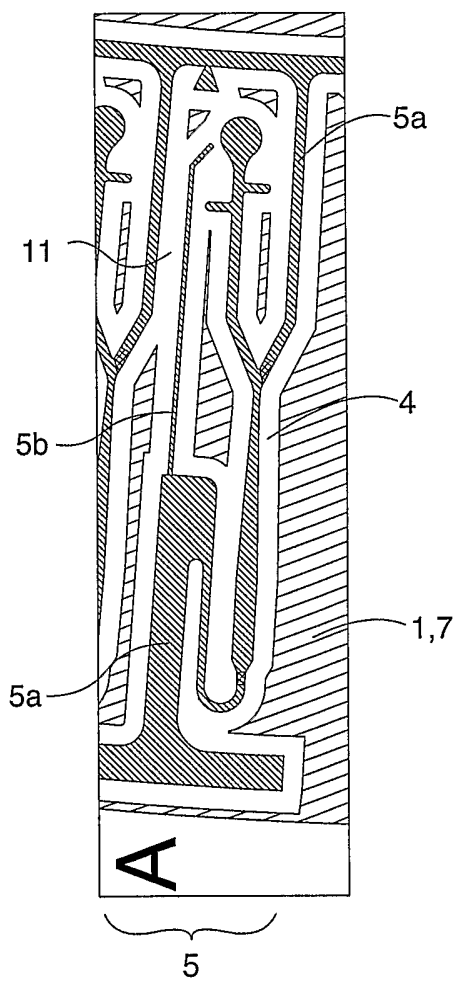

Fig. 2

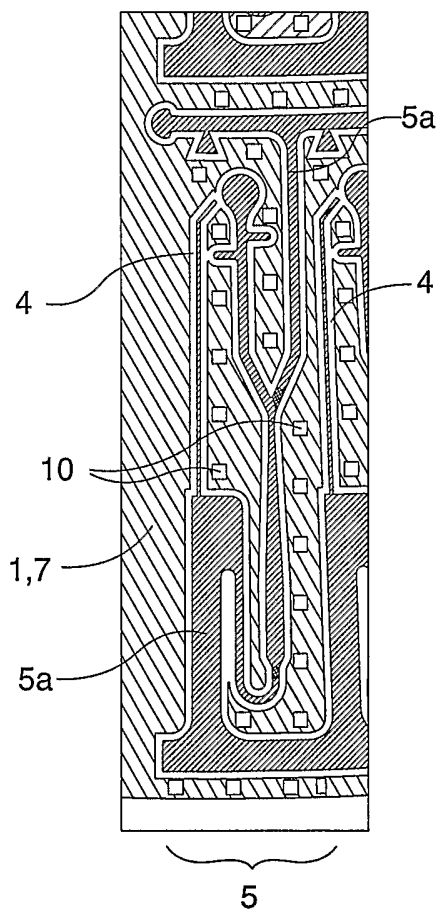
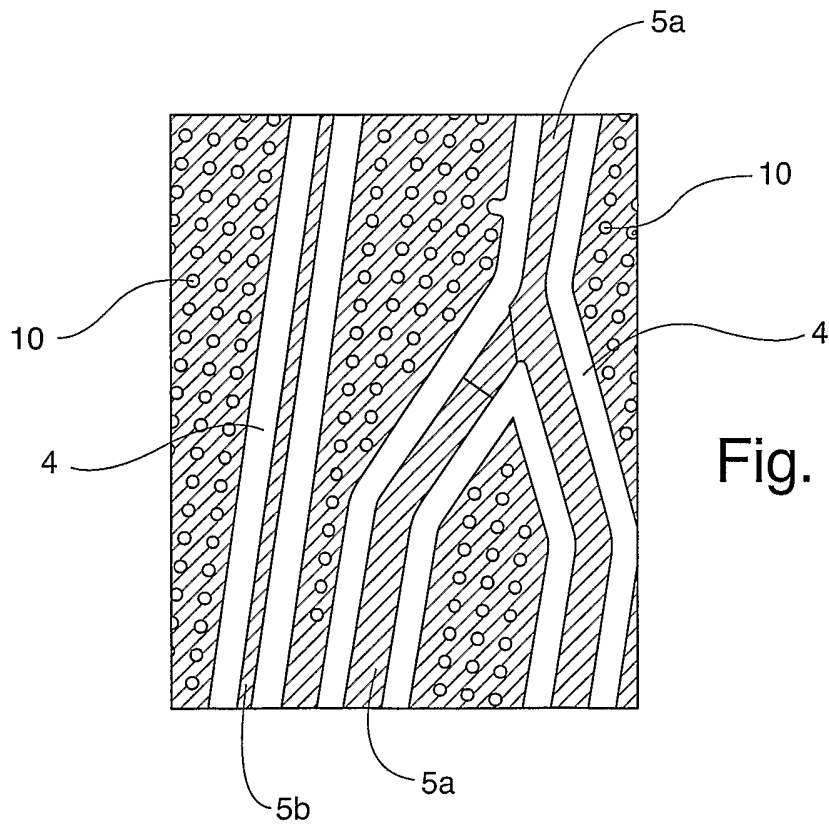
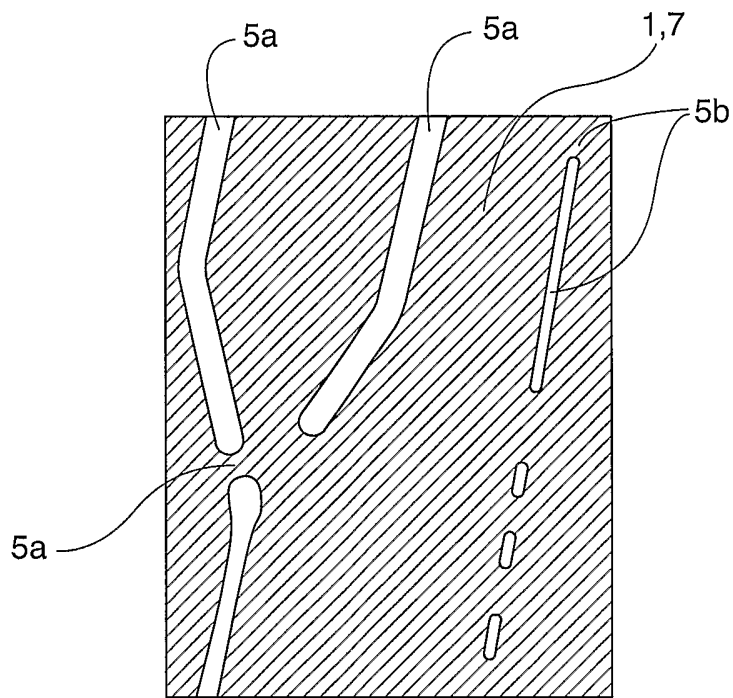

Fig. 3

5/5



## INTERNATIONAL SEARCH REPORT

International application No.

PCT/SE 02/02431

A. CLASSIFICATION OF SUBJECT MATTER		
IPC7: B81C 1/00, B81B 1/00, B32B 31/14 According to International Patent Classification (IPC) or to both national classification and IPC		
B. FIELDS SEARCHED		
Minimum documentation searched (classification system followed by classification symbols)		
IPC7: B81C, B81B, B32B		
Documentation searched other than minimum documentation to the extent that such documents are included in the fields searched		
SE,DK,FI,NO classes as above		
Electronic data base consulted during the international search (name of data base and, where practicable, search terms used)		
C. DOCUMENTS CONSIDERED TO BE RELEVANT		
Category*	Citation of document, with indication, where appropriate, of the relevant passages	Relevant to claim No.
X	WO 0130490 A1 (ACLARA BIOSCIENCES, INC.), 3 May 2001 (03.05.01), page 2, line 10 - line 19; page 4, line 2 - line 8; page 7, line 7 - page 8, line 3, figure 3 --	1,14
X	US 6126765 A (OVE ÖHMAN), 3 October 2000 (03.10.00), column 1, line 27 - column 3, line 12 --	1-23
X	WO 0050871 A1 (ORCHID BIOSCIENCES, INC.), 31 August 2000 (31.08.00), page 8, line 22 - page 9, line 10; page 18, line 5 - line 19; page 20, line 1 - page 21, line 15, page 23, line 25 - page 24, line 16; figures 1,3 --	1-23
<input checked="" type="checkbox"/> Further documents are listed in the continuation of Box C. <input checked="" type="checkbox"/> See patent family annex.		
* Special categories of cited documents: "A" document defining the general state of the art which is not considered to be of particular relevance "E" earlier application or patent but published on or after the international filing date "L" document which may throw doubts on priority claim(s) or which is cited to establish the publication date of another citation or other special reason (as specified) "O" document referring to an oral disclosure, use, exhibition or other means "P" document published prior to the international filing date but later than the priority date claimed "T" later document published after the international filing date or priority date and not in conflict with the application but cited to understand the principle or theory underlying the invention "X" document of particular relevance: the claimed invention cannot be considered novel or cannot be considered to involve an inventive step when the document is taken alone "Y" document of particular relevance: the claimed invention cannot be considered to involve an inventive step when the document is combined with one or more other such documents, such combination being obvious to a person skilled in the art "&" document member of the same patent family		
Date of the actual completion of the international search		Date of mailing of the international search report
27 March 2003		01-04-2003
Name and mailing address of the ISA/ Swedish Patent Office Box 5055, S-102 42 STOCKHOLM Facsimile No. +46 8 666 02 86		Authorized officer Fredrik Wahlin/MN Telephone No. +46 8 782 25 00



## INTERNATIONAL SEARCH REPORT

International application No.

PCT/SE 02/02431

## C (Continuation). DOCUMENTS CONSIDERED TO BE RELEVANT

Category*	Citation of document, with indication, where appropriate, of the relevant passages	Relevant to claim No.
A	US 6123798 A (KHUSHROO GANDHI ET AL), 26 Sept 2000 (26.09.00), column 9, line 34 - column 10, line 10; column 12, line 33 - line 60  --- -----	1-23

## INTERNATIONAL SEARCH REPORT

Information on patent family members

30/12/02

International application No.

PCT/SE 02/02431

Patent document cited in search report			Publication date	Patent family member(s)		Publication date
WO	0130490	A1	03/05/01	AU	1970101 A	08/05/01
				EP	1225977 A	31/07/02
US	6126765	A	03/10/00	DE	69406020 D,T	26/02/98
				EP	0738306 A,B	23/10/96
				ES	2109706 T	16/01/98
				JP	9502795 T	18/03/97
				SE	501380 C	30/01/95
				SE	9302051 A	16/12/94
				WO	9429400 A	22/12/94
				AU	1163595 A	31/08/95
				CA	2142953 A	22/08/95
				EP	0668025 A	23/08/95
				FI	950501 A	04/08/96
				JP	8038066 A	13/02/96
				NO	950621 A	22/08/95
				SE	9400584 D	00/00/00
WO	0050871	A1	31/08/00	AU	3508600 A	14/09/00
US	6123798	A	26/09/00	AU	754681 B	21/11/02
				AU	2583199 A	23/08/99
				AU	3783299 A	23/11/99
				CA	2319484 A	12/08/99
				CA	2329623 A	11/11/99
				EP	1058550 A	13/12/00
				EP	1115573 A	18/07/01
				IL	137671 D	00/00/00
				JP	2002511387 T	16/04/02
				WO	9939712 A	12/08/99
				WO	9956954 A	11/11/99