



INTERNATIONAL APPLICATION PUBLISHED UNDER THE PATENT COOPERATION TREATY (PCT)

<p>(51) International Patent Classification ⁶ : A61F 2/16</p>	<p>A1</p>	<p>(11) International Publication Number: WO 98/56315 (43) International Publication Date: 17 December 1998 (17.12.98)</p>
<p>(21) International Application Number: PCT/US98/12259 (22) International Filing Date: 12 June 1998 (12.06.98) (30) Priority Data: 08/874,753 13 June 1997 (13.06.97) US (71) Applicant: CHIRON VISION CORPORATION [US/US]; One Bausch & Lomb Place, Rochester, NY 14604-2701 (US). (72) Inventor: NIGAM, Alok; 21381 Birdhollow Drive, Trabuco Canyon, CA 92679 (US). (74) Agents: VACCA, Rita, D. et al.; Chiron Vision Corporation, One Bausch & Lomb Place, Rochester, NY 14604-2701 (US).</p>		<p>(81) Designated States: AL, AM, AT, AU, AZ, BA, BB, BG, BR, BY, CA, CH, CN, CU, CZ, DE, DK, EE, ES, FI, GB, GE, GH, GM, GW, HU, ID, IL, IS, JP, KE, KG, KP, KR, KZ, LC, LK, LR, LS, LT, LU, LV, MD, MG, MK, MN, MW, MX, NO, NZ, PL, PT, RO, RU, SD, SE, SG, SI, SK, SL, TJ, TM, TR, TT, UA, UG, UZ, VN, YU, ZW, ARIPO patent (GH, GM, KE, LS, MW, SD, SZ, UG, ZW), Eurasian patent (AM, AZ, BY, KG, KZ, MD, RU, TJ, TM), European patent (AT, BE, CH, CY, DE, DK, ES, FI, FR, GB, GR, IE, IT, LU, MC, NL, PT, SE), OAPI patent (BF, BJ, CF, CG, CI, CM, GA, GN, ML, MR, NE, SN, TD, TG).</p> <p>Published <i>With international search report. Before the expiration of the time limit for amending the claims and to be republished in the event of the receipt of amendments.</i></p>

(54) Title: INTRAOCULAR LENS

(57) Abstract

A refractive intraocular lens (20) includes an optic portion (22) having an outer peripheral edge (24) and at least two haptic element (26) each having an inner portion (28) and an outer end (30) for supporting the optic portion (22) in a patient's eye (10), the respective inner portions (28) of the haptic elements (26) being connected to the outer peripheral edge (24) of the optic portion (22). Each haptic element (26) includes at least one footplate (32) on the outer end (30), and further includes a central portion (38) extending between the footplate (32) and the inner portion (28). The central portion (38) of each haptic element (26) has a greater resistance to bending in a plane (40-40) generally parallel to an optical axis (OA-OA) of the patient's eye (10) than in a plane (36-36) generally perpendicular to the optical axis (OA-OA). The optic portion (22) and haptic elements (26) are preferably formed of a foldable or compressible material.

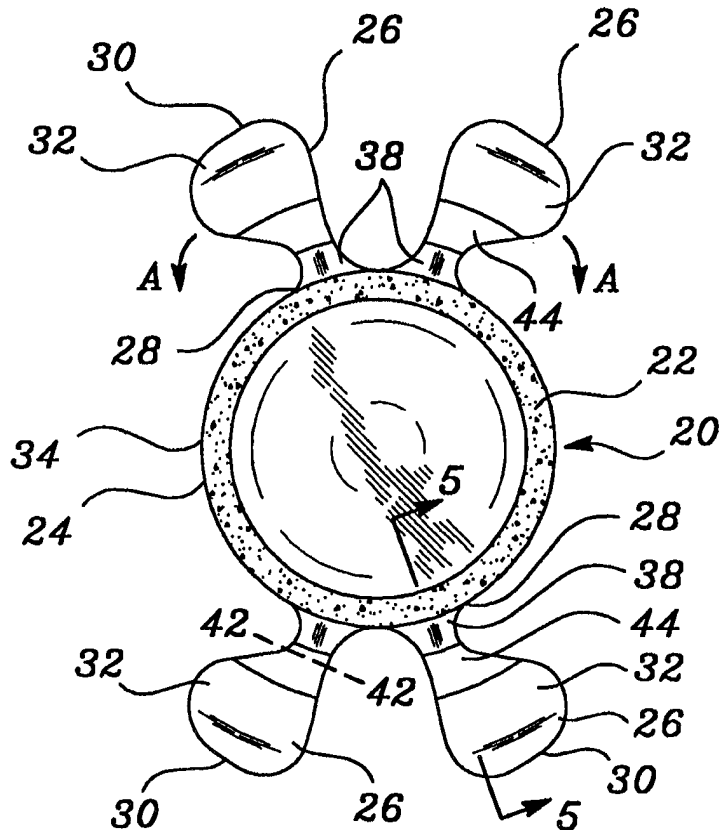

FOR THE PURPOSES OF INFORMATION ONLY

Codes used to identify States party to the PCT on the front pages of pamphlets publishing international applications under the PCT.

AL	Albania	ES	Spain	LS	Lesotho	SI	Slovenia
AM	Armenia	FI	Finland	LT	Lithuania	SK	Slovakia
AT	Austria	FR	France	LU	Luxembourg	SN	Senegal
AU	Australia	GA	Gabon	LV	Latvia	SZ	Swaziland
AZ	Azerbaijan	GB	United Kingdom	MC	Monaco	TD	Chad
BA	Bosnia and Herzegovina	GE	Georgia	MD	Republic of Moldova	TG	Togo
BB	Barbados	GH	Ghana	MG	Madagascar	TJ	Tajikistan
BE	Belgium	GN	Guinea	MK	The former Yugoslav Republic of Macedonia	TM	Turkmenistan
BF	Burkina Faso	GR	Greece	ML	Mali	TR	Turkey
BG	Bulgaria	HU	Hungary	MN	Mongolia	TT	Trinidad and Tobago
BJ	Benin	IE	Ireland	MR	Mauritania	UA	Ukraine
BR	Brazil	IL	Israel	MW	Malawi	UG	Uganda
BY	Belarus	IS	Iceland	MX	Mexico	US	United States of America
CA	Canada	IT	Italy	NE	Niger	UZ	Uzbekistan
CF	Central African Republic	JP	Japan	NL	Netherlands	VN	Viet Nam
CG	Congo	KE	Kenya	NO	Norway	YU	Yugoslavia
CH	Switzerland	KG	Kyrgyzstan	NZ	New Zealand	ZW	Zimbabwe
CI	Côte d'Ivoire	KP	Democratic People's Republic of Korea	PL	Poland		
CM	Cameroon	KR	Republic of Korea	PT	Portugal		
CN	China	KZ	Kazakstan	RO	Romania		
CU	Cuba	LC	Saint Lucia	RU	Russian Federation		
CZ	Czech Republic	LI	Liechtenstein	SD	Sudan		
DE	Germany	LK	Sri Lanka	SE	Sweden		
DK	Denmark	LR	Liberia	SG	Singapore		
EE	Estonia						

INTRAOCULAR LENS

5

TECHNICAL FIELD

This invention relates to intraocular lenses ("IOL"), and more particularly to IOLs designed primarily for refractive correction in phakic eyes where the natural lens remains intact, although IOLs made in accordance with the invention may also be used in aphakic eyes where the natural lens is removed as a result of a cataract.

BACKGROUND ART

15 Visual acuity deficiencies such as myopia (nearsightedness) and hyperopia (farsightedness) are typically corrected with use of refractive lenses such as spectacles or contact lenses. Although these types of lenses are effective in correcting a wearer's eyesight, many wearers consider them inconvenient because they have to be located, worn at certain times, removed periodically and can be lost or misplaced. They can also be dangerous or cumbersome if the wearer participates in sports activities or suffers impact to the eye.

The use of IOLs as a permanent form of refractive correction has been gaining popularity. IOLs have been used for years in aphakic eyes as a replacement for the natural crystalline lens of the eye which has been removed as a result of a cataract. Many different designs have been developed and proved to be successful for IOLs used in aphakic eyes. They primarily include an optic portion and supports, called haptics, connected to and surrounding at least part of the optic portion, for supporting the IOL in the eye in either the anterior or posterior chamber.

IOLs have been made from a variety of biocompatible materials, ranging from the so-called rigid materials such as polymethylmethacrylate (PMMA) to the so-called soft materials that can be folded or compressed such as silicones, certain acrylics, and hydrogels. Haptics have been formed separately from the optic portion and connected through processes such as heat or physical staking and chemical

- 2 -

bonding. They have also been formed as an integral part of the optic portion in the so-called single piece IOLs.

Soft IOLs have gained popularity because they can be compressed, folded, rolled or otherwise deformed and inserted through an incision in the cornea that is much smaller than necessary for the rigid lenses which must be inserted through an incision slightly larger than the diameter of the optic portion. When implanted in the eye, these soft lenses then open to their original shape because of the memory characteristics of the soft materials.

When implanted, both soft and rigid IOLs are subject to compressive forces exerted on their outer ends, which typically occur when the individual squints or rubs his or her eye. These compressive forces can result in decentration of the optic and distortion of the visual image because the compressive forces tend to cause translational movement along the optical axis. Movement in this direction could cause the IOL to contact and damage the delicate corneal endothelial layer. Also, because IOLs of current designs, whether formed of soft or rigid materials, tend to deflect along the optical axis when the haptics are compressed, IOL manufacturers have had to provide a range of sizes to fit the IOL to a particular patient's eye to minimize the potential for this movement and thus provide more certain refractive correction.

Because of these shortcomings in IOL designs, there is a need for a haptic design that minimizes translational movement of the optic portion along the optical axis when compressive forces are exerted against the outer ends of the haptics.

DISCLOSURE OF THE INVENTION

25

An intraocular lens (IOL) made in accordance with the invention has an optic portion with an outer peripheral edge and at least two haptic elements for supporting the optic portion in a patient's eye and is formed of a foldable or compressible material. Each haptic element has an inner portion and an outer end with the inner portion being connected to the outer peripheral edge of the optic portion. Each haptic element includes at least one footplate on the

30

- 3 -

outer end and a central portion that extends between the footplate and the inner portion. The footplates are designed to engage an inner surface of the patient's eye.

The haptic elements have greater resistance to bending in a plane generally parallel to the optical axis of the eye than in a plane generally perpendicular to the optical axis. By providing haptic elements with this type of flexibility characteristic, the inventive IOL can fit eyes of different sizes due to the flexing of the haptic elements relative to the optic portion, without causing unacceptable translational movement of the optic portion along the optical axis when compressive forces are exerted against the haptic elements.

BRIEF DESCRIPTION OF DRAWINGS

The invention can be better understood when the detailed description of exemplary embodiments set forth below is considered in conjunction with the appended drawings, in which:

FIGURE 1 is a schematic representation of the interior of the human eye, that includes the natural lens and a refractive IOL implanted in the anterior chamber;

FIGURE 2 is a top plan view of an IOL made in accordance with the invention;

FIGURE 3 is a dimensional end view of the IOL of Fig. 2;

FIGURE 4 is a dimensional side view of the IOL of Fig. 2;

FIGURE 5 is a partial side sectional view of the optic portion, one of the haptic elements and footplate of the IOL of Fig. 2 looking along the site line 5-5 of Fig. 2;

FIGURE 6 is a top plan view of an alternate IOL made in accordance with the invention;

FIGURE 7 is a dimensional end view of the IOL of Fig. 6;

FIGURE 8 is a dimensional side view of the IOL of Fig. 6;

- 4 -

FIGURE 9 is a partial side sectional view of the optic portion and one of the haptic elements of the IOL of Fig. 6 looking along the site line 9-9 of Fig. 6;

FIGURE 10 is a top plan view of an alternate IOL made in accordance with the invention;

FIGURE 11 is a dimensional end view of the IOL of Fig. 10;

FIGURE 12 is dimensional side view of the IOL of Fig. 10;

FIGURE 13 is a top plan view of a haptic element and footplate with an embedded stiffening element; and

FIGURE 14 is a side sectional view of the haptic element and footplate of Fig. 13.

BEST MODES FOR CARRYING OUT THE INVENTION AND INDUSTRIAL APPLICABILITY

Fig. 1 illustrates a simplified diagram of an eye 10 showing landmark structures relevant to the implantation of an intraocular lens of the present invention. The eye 10 includes an optically clear cornea 12 and an iris 14. A natural crystalline lens 16 and a retina 18 are located behind the iris 14. The eye 10 also includes an anterior chamber 6 located in front of the iris 14 and a posterior chamber 8 located between the iris 14 and the natural lens 16. The IOLs of the present invention are preferably implanted in the anterior chamber 6 to correct refractive errors when the natural lens 16 remains in place (phakic application). IOLs of the present invention may also be implanted in the posterior chamber 8, and may be used in aphakic eyes as a replacement for a natural lens 16 in cataract surgery. The eye 10 also includes an optical axis OA-OA which is an imaginary line that passes through the optical centers of both surfaces of any lens, and in the human eye is generally perpendicular to the cornea 12, the natural lens 16 and the retina 18 of the eye 10.

The IOL of the present invention is designed with flexibility characteristics that cause the supports or haptic elements to move toward the

- 5 -

optic portion when compressive forces are exerted on their outer ends, with minimal translational movement along the optical axis OA-OA for preventing decentering of the IOL, distortion of vision, and corneal endothelial touch. These flexibility characteristics also permit one or several standard lens sizes of each style to be suitable for eyes of most sizes. By providing universal lenses of this type, the risk of implanting an improper sized lens is reduced, which is beneficial to the patient because many clinical problems, such as pupil ovalization, corneal endothelial damage and poor fixation are eliminated. Also, the need to make IOLs of many sizes for each style is eliminated and inventory costs are reduced. An IOL made in accordance with the subject invention is more forgiving from a size point of view and the ophthalmologist saves time by not having to measure the patient's eye chamber and select a specific size IOL for each procedure.

Although the present invention is preferably applied to soft or foldable IOLs, which are formed of a foldable or compressible material, it can also be used in conjunction with the so-called hard lenses which have optic portions formed of a relatively rigid material such as polymethylmethacrylate (PMMA) and have flexible haptics either formed of the same ("single-piece IOLs") or different ("multiple-piece IOLs") material.

The preferable soft material of the lens of the present invention is a hydrogel known as hefilcon A, which has a high water content and refractive index greater than the aqueous humor of the eye (+1.33), a feature that is desirable to impart optical power for use as a refractive lens. This material also has the mechanical strength to withstand physical manipulation during implantation and good memory properties so that the IOL can unfold in the eye into a predetermined shape and have dimensional stability in the eye. However, other suitable foldable or compressible materials, such as silicone polymers, hydrocarbon and fluorocarbon polymers, other hydrogels, soft acrylic polymers, polyesters, polyamides, polyurethane, silicone polymers with hydrophilic monomer units, fluorine-containing polysiloxane elastomers and combinations thereof could also be used.

When used as a refractive lens, the optic portion can be a positive powered lens from 0 to approximately +20 diopters, or a negative powered lens from 0 to approximately -25 diopters. The optic portion can be biconvex, plano-convex, plano-concave, biconcave or concave-convex (meniscus), depending upon the power required to achieve the appropriate central and peripheral thickness for efficient handling.

One embodiment of the present invention is shown in Figs. 2-5 where an IOL, identified by reference numeral 20, is designed for implantation preferably in the anterior chamber of a patient's eye. The IOL 20 has an optic portion 22 with an outer peripheral edge 24. In this embodiment, four separate haptic elements 26, each having an inner portion 28 and an outer end 30, are connected through their inner portions 28 to the outer peripheral edge 24 of the optic portion 22. Each haptic element 26 also includes a relatively flat footplate 32, that is designed to engage the inner surface of the eye through the rounded outer end 30. The haptics may be integrally formed with the optic or the haptics may be attached by staking, chemical polymerization or other known methods.

The optic portion 22 can be formed with a glare reduction zone 34 adjacent to the outer peripheral edge 24 for reducing glare where the edge of the lens is struck by light entering the pupil or during high light or at other times when the pupil is dilated. The glare reduction zone 34 is typically fabricated of the same material as the optic portion 22, but may be opaque, colored or patterned to block or diffuse light in the optical plane.

In accordance with the invention, the haptic elements 26 are designed so that when the IOL 20 is implanted in a patient's eye and held in place through compressive forces exerted on the outer ends 30 of the haptic elements 26, the haptic elements 26 will flex in a plane 36-36 (Fig. 4) in the direction of arrows A (Fig. 2), generally perpendicular to an optical axis OA-OA of the IOL 20. By designing this type of flexibility characteristic into the haptic elements 26, an IOL 20 of one or several standard sizes will be suitable for most sizes of patient's eyes because little, if any, translational movement of the

IOL 20 will occur in a direction generally parallel to the optical axis OA-OA when compressive forces of different magnitudes (i.e., as caused by eyes of different sizes) are exerted against the outer ends 30 of the haptic elements 26.

Another benefit of the IOLs designed in accordance with the present invention is protection of the corneal endothelium from contact by the IOL when compressive forces are applied to the eye because the IOL will not move into contact with the endothelium.

This flexibility characteristic can be achieved in several different ways.

In IOL 20 shown in Figs 2-5, the haptic elements 26 are formed with a central portion 38 adjacent to the optic portion 22, central portion 38 has a dimension in the plane 40-40 (generally parallel to the optical axis OA-OA (Fig. 4)), that is equal to or greater than a dimension in the plane 42-42 (Fig. 3) (generally perpendicular to the optical axis OA-OA). A transition portion 44, of a decreasing size in the dimension 40-40, extends from the central portion 38 to the footplate 32. The footplates 32 are relatively flat (see Figs. 3, 4).

Typical dimensions for an IOL of this style include generally: a 5.5 mm diameter optic portion 22 that is about 0.7 mm thick at the peripheral edge 24; haptic portions 26 that are about 3.5 mm long from their inner portion 28 to the outer end 30; a central portion 38 that is about 1.5 mm long, about 0.7 mm thick in the plane 40-40 and about 0.7 mm wide in the plane 42-42; a transitional portion that is about 0.5 mm long; and a footplate 32 that is about 3.0 mm wide, about 2.0 mm long and about 0.3 mm thick.

Thus, the haptic elements 26 gradually change from being relatively thin (in the plane 40-40) at the footplates 32, to being relatively thick at the connection of the inner portion 28 and the optic portion 22, with the central portion 38 in this design being generally equal in the plane 40-40 and in the plane 42-42. Haptic elements with this shape in the direction of arrows A in Fig. 2, will tend to flex toward the optic portion 22 when a compression force is exerted against the outer ends 30, with a minimal translational motion along the optical axis OA-OA. When the IOL 20 is used as a refractive lens, a stable, reliable refractive correction is provided.

Another IOL 20A, made in accordance with the invention, is shown in Figs. 6-9, where two haptic elements 26A are provided on one side of the optic and one haptic element 26 is provided on the other side. The flexibility characteristic of the IOL 20A is provided for in a different way than that described above for IOL 20. Instead of a transition portion 44, the haptic elements 26 have a greater thickness in the plane 42-42 than in the plane 40-40. As shown in particular in Figs. 8 and 9, the footplates 32 gradually increase in thickness from the outer ends 30 to the central portion 38, with the central portions 38 having a width that is of a much greater diameter than that in the plane 40-40. This shape allows the haptic elements 26B to flex toward the optic portion, as shown by arrows B in Fig 6, as a compressive force is exerted against the outer ends 30.

Another embodiment of the inventive lens, IOL 20B, is shown in Figs. 10-12. The IOL 20B has two haptic elements 26B with a pair of footplates 32B formed at the outer end of each haptic element 26B. Alternatively, a pair of footplates 32B can be formed on only one haptic element 26B with the opposing side of the optic portion 28 having a haptic element of another suitable design.

IOL 20B also includes an inner portion 28 and an outer end 30. The haptic elements 26B are connected through thin inner portions 28 to the outer peripheral edge 24 of the optic portion 22. The footplates 32B are designed to engage the inner surface of the eye, through the rounded outer end 30.

As in IOL 20, the haptic elements 26B are designed so that when IOL 20B is implanted in a patient's eye and held in place through compressive forces exerted on the outer ends 30 of the haptic elements 26B, the haptic elements 26B will flex in a plane 36-36 (Fig. 12) in the direction of arrows C (Fig. 10) generally perpendicular to an optical axis OA-OA of the IOL 20B.

The flexibility characteristics of the IOL 20B is achieved by the haptic elements 26B being formed with the central portion 38 having a dimension in the plane 40-40 (generally parallel to the optical axis OA-OA (Fig. 12)), that is equal to or greater than a dimension in the plane 42-42 (generally

perpendicular to the optical axis) (Figs. 10 and 12). A transition portion 44, of a decreasing size in the dimension 40-40, extends from the central portion 38 to the junction of the footplates 32B. The footplates 32B are relatively flat (Figs. 11 and 12). Haptic elements with this shape will tend to flex toward the optic portion 22 when a compressive force is exerted against the outer ends 30, with a minimal translational motion along the optical axis OA-OA.

Another way the desired flexibility characteristic of the IOLs of the present invention can be achieved is by incorporating a stiffening element 46, in the shape of a ribbon, in one or more of the haptic portions 26, as shown in Figs. 13 and 14. The ribbon 46 is formed of a relatively strong material. It can be used in conjunction with the haptic shapes described above, or it can be used with conventional haptic designs to achieve the desired flexibility characteristics.

The ribbon 46 can be inserted so that its flat face is oriented parallel to the dimension 40-40 as shown in Fig. 14. The ribbon 46 can also be inserted to conform to the curvature of the edges of the haptic element 26, as shown in Fig. 13. The ribbon 46 is formed of a material that is relatively stiff compared to the material of the haptic element. Suitable materials can include a polyimide, polyolefin, HDPE, polyester, nylon, metal or any other material with suitable stiffening characteristics. The material does not have to be biocompatible when it is totally encapsulated in the IOL. The ribbon 46 operates like an I-beam to prevent translational movement along the optical axis OA-OA when compressive force is applied to the outer ends of the haptic elements 26.

The IOLs of the present invention provide for a refractive lens that can be manufactured in a number of different styles that are suitable for use in the anterior chamber of the eye. The inventive IOL has haptics with flexibility characteristics that allow only minimal translational motion along the optical axis OA-OA, therefore preventing decentration of the lens, distortion of vision, and damage to the corneal endothelial cells. The IOLs of the present invention with these flexibility characteristics are also advantageous because only one or

several sizes of lens of each style is needed to accommodate the eyes of most patients. By providing universal lenses of this type, the clinical risks to patients because of improper lens size are minimized and the need to make IOLs of many sizes for each style is eliminated and inventory costs are
5 reduced.

Although particular embodiments of the invention have been described in detail for purposes of illustration, various modifications may be made without departing from the spirit and scope of the invention as defined by the appended claims.

What is claimed is:

1. An intraocular lens (20) to be positioned generally perpendicular to the optical axis (OA-OA) of the eye (10) when implanted in a patient's eye (10), comprising:

(a) an optic portion (22) having an outer peripheral edge(24);

(b) at least two haptic elements (26) each having an inner portion (28) and an outer end (30) for supporting the optic portion (22) in a patient's eye (10), the respective inner portions (28) of the haptic elements (26) being connected to the outer peripheral edge (24) of the optic portion (22);

(c) each haptic element (26) including at least one footplate (32) on the outer end (30), and further including a central portion (38) extending between the footplate (32) and the inner portion (22); and

(d) the central portion (38) of each haptic element (26) having a greater resistance to bending in a plane (40-40) generally parallel to an optical axis (OA-OA) of the patient's eye (10) than in a plane (36-36) generally perpendicular to the optical axis (OA-OA).

2. The intraocular lens (20) of claim 1, wherein the optic portion (22) and haptic elements (26) are formed of a foldable or compressible material.

3. The intraocular lens (20) of claim 2, wherein the foldable or compressible material is selected from the group consisting of silicone polymers, hydrocarbon and fluorocarbon polymers, hydrogels, soft acrylic polymers, polyester, polyamides, polyurethane, silicone polymers with hydrophilic monomer units, fluorine-containing polysiloxane elastomers and combinations thereof.

4. The intraocular lens (20) of claim 3, wherein the hydrogel material is hefilcon A.

- 12 -

5. The intraocular lens (20) of claim 1, wherein the footplates (32) are relatively flat in the plane (36-36) generally perpendicular to the optical axis (OA-OA).

6. The intraocular lens (20) of claim 1, wherein the central portion (38) of at least one haptic element (26) is formed with a dimension equal to or greater in the plane (40-40) generally parallel to the optical axis (OA-OA) than in the plane (42-42) generally perpendicular to the optical axis (OA-OA).

7. The intraocular lens (20) of claim 6, wherein all of the haptic elements (26) have a central portion (38) formed with a dimension equal to or greater in the plane (40-40) generally parallel to the optical axis (OA-OA) than in the plane (42-42) generally perpendicular to the optical axis (OA-OA).

8. The intraocular lens (20) of claim 1, wherein the central portion (38) of one haptic element (26) is formed with a dimension equal to or greater in the plane (42-42) generally perpendicular to the optical axis (OA-OA) than the dimension of the footplate (32) in the same plane (42-42).

9. The intraocular lens (20) of claims 7 or 8, wherein the haptic elements (26) include a transition zone (44) of increasing thickness in the plane (40-40) generally parallel to the optical axis (OA-OA), the transition zone (44) extending from the footplate (32) to the central portion (38).

10. The intraocular lens (20) of claim 6, wherein the inner portion (22) of the at least one haptic element (26) has a dimension in the plane (40-40) generally parallel to the optical axis (OA-OA) that is essentially the same as the dimension of the central portion (38) and the optic portion (22) in the same plane (40-40).

- 13 -

11. The intraocular lens (20) of claim 1, wherein the at least two haptic elements (26) include two haptic elements (26) on a first side of the optic portion (22) and at least one haptic element (26) on a second side of the optic portion (22).

12. The intraocular lens (20) of claim 1, wherein the at least two haptic elements (26) include two haptic elements (26) on a first side of the optic portion (22) and two haptic elements (26) on a second side of the optic portion (22).

13. The intraocular lens (20) of claim 1, wherein the at least two haptic elements (26) include one haptic element (26) on a first side of the optic portion (22) and a second haptic element (26) on a opposite side of the optic portion (22), with a pair of footplates (32) connected to the outer end (30) of at least one of the haptic elements (26).

14. The intraocular lens (20) of claim 1, wherein a glare reduction zone (34) is formed adjacent to the outer peripheral edge (24) of the optical portion (22).

15. The intraocular lens (20) of claim 1, and further including a stiffening element (46) incorporated in at least one of the haptic elements (26), the stiffening element (46) having a greater resistance to bending in the plane (40-40) generally parallel to the optical axis (OA-OA) than in the plane (36-36) generally perpendicular to the optical axis (OA-OA).

16. The intraocular lens (20) of claim 15, wherein the stiffening element (46) is formed of an elongated length of material having a dimension in the plane (40-40) generally parallel to the optical axis (OA-OA) greater than the dimension of the plane (42-42) generally perpendicular to the optical axis (OA-OA).

- 14 -

17. The intraocular lens (20) of claim 15, wherein the stiffening element (46) extends into the footplate (32).

18. The intraocular lens (20) of claim 15, wherein the stiffening element (46) is formed of a material selected from the group consisting of polyimide, polyolefin, HDPE, polyester, nylon and metal.

19. The intraocular lens (20) of claim 15, wherein all of the haptic elements (26) include the stiffening element (46).

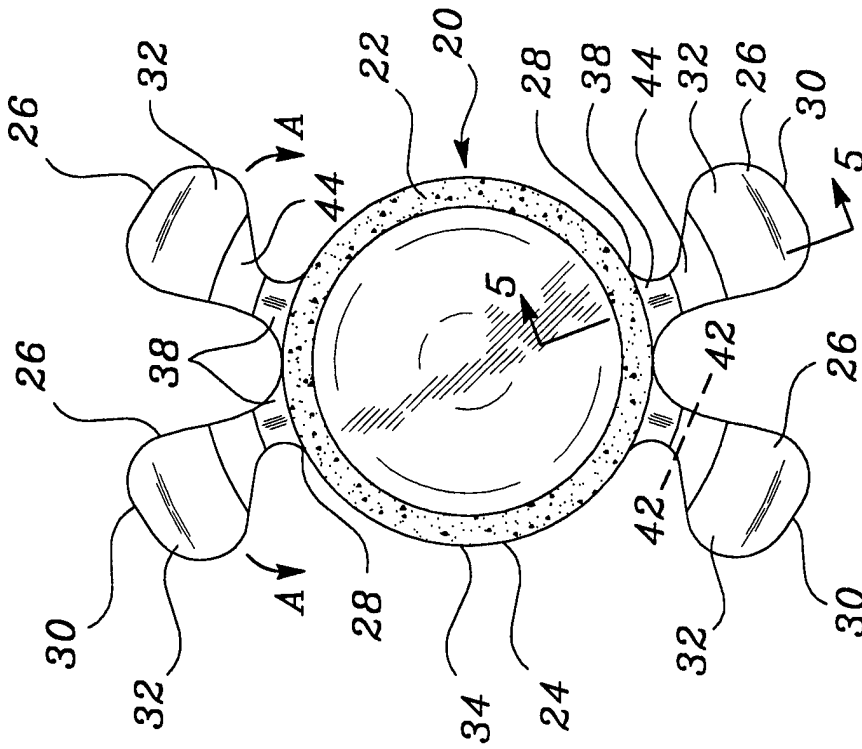

figure 2

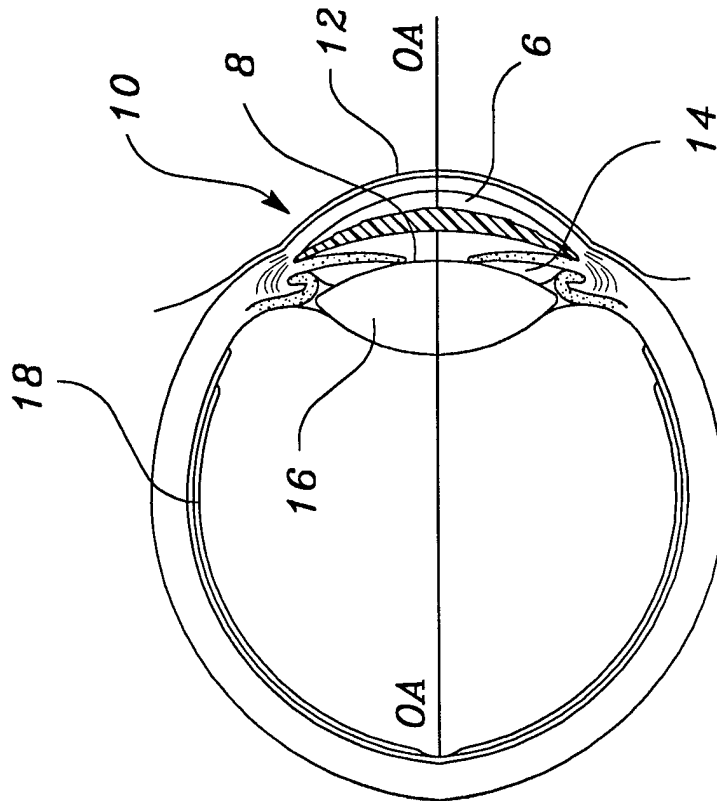
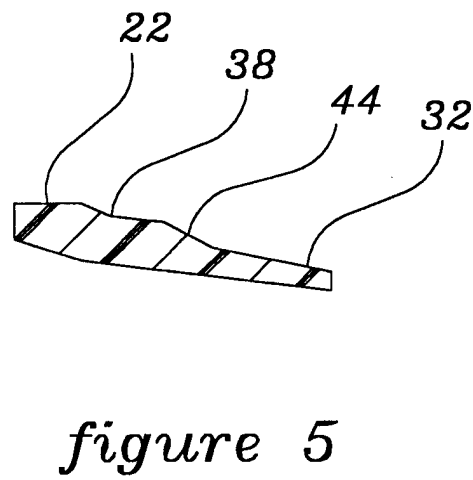
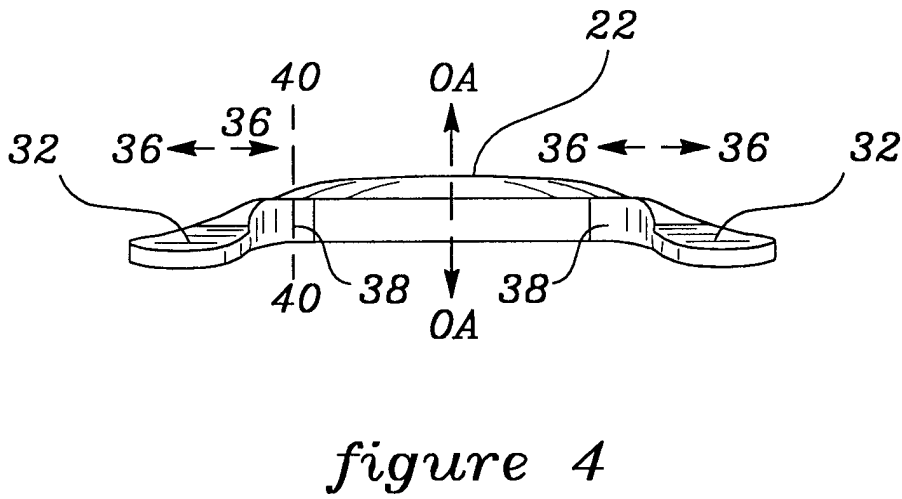
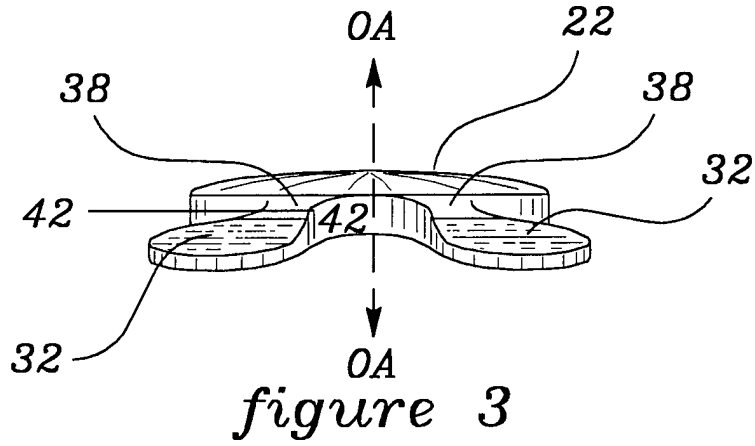
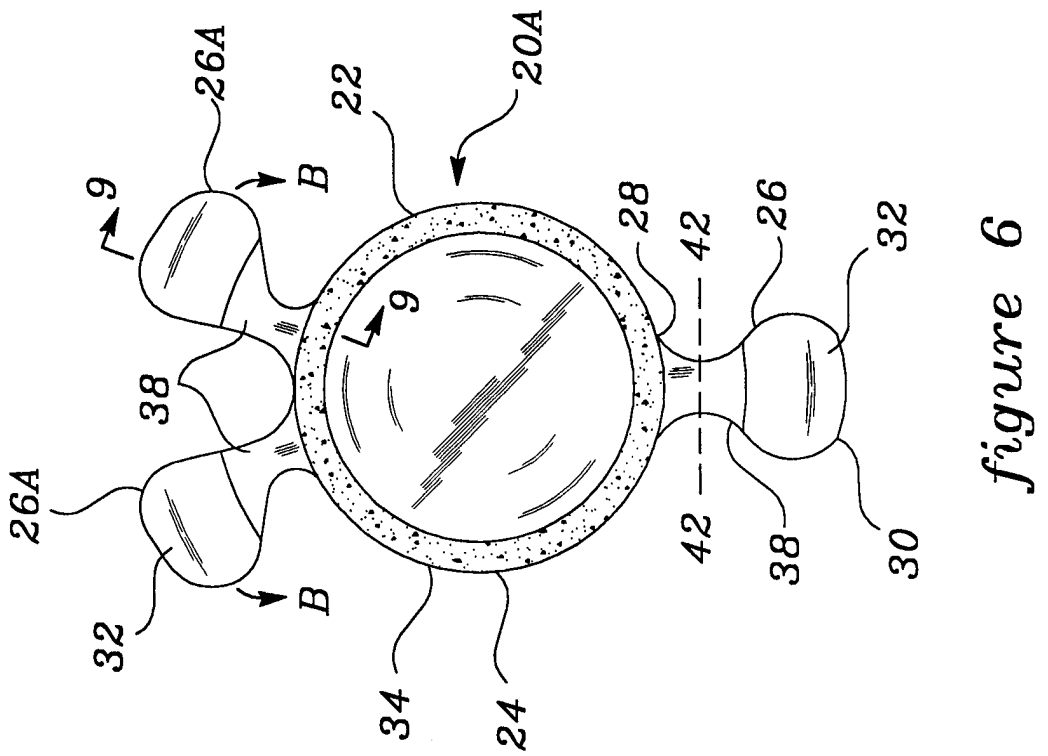
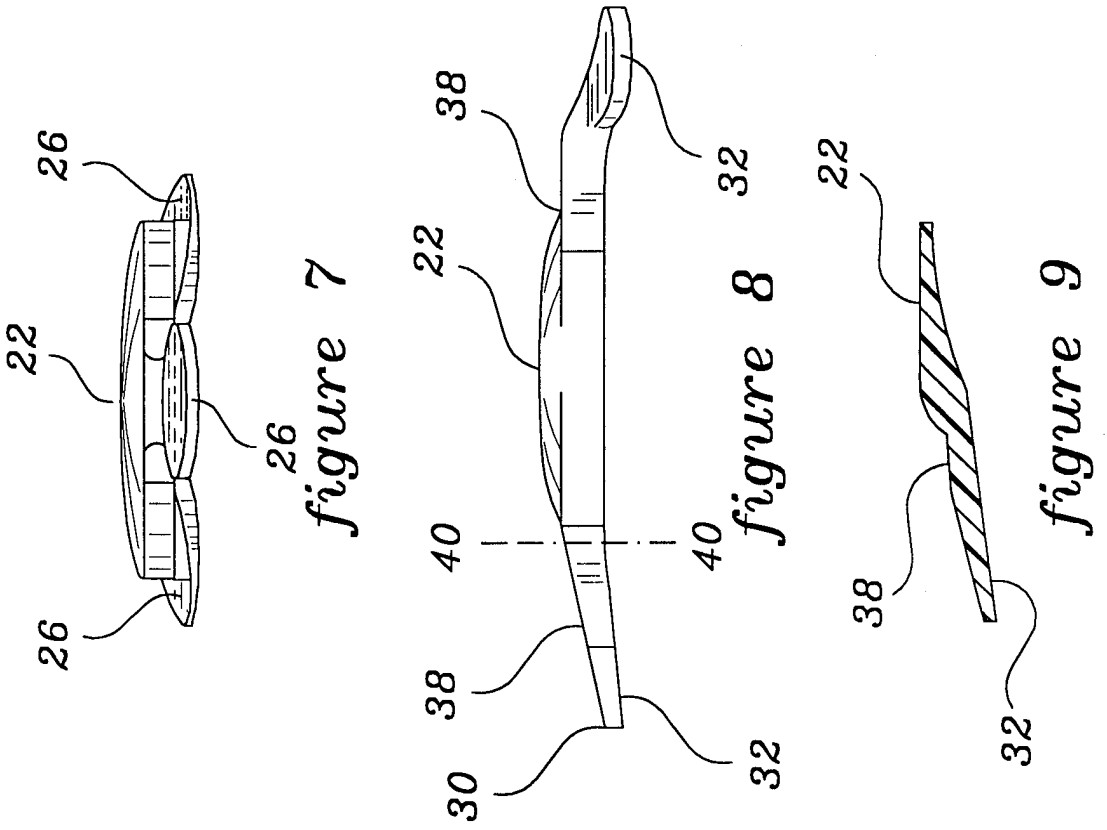

figure 1





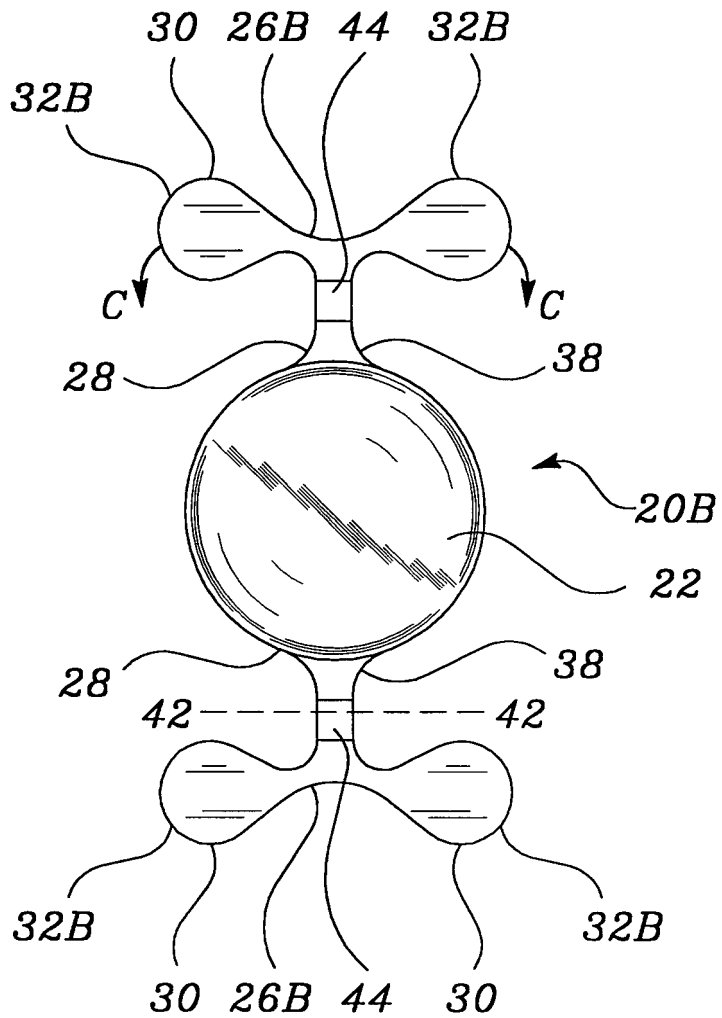

figure 10

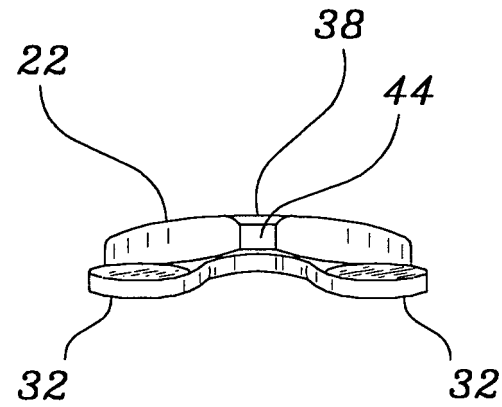

figure 11

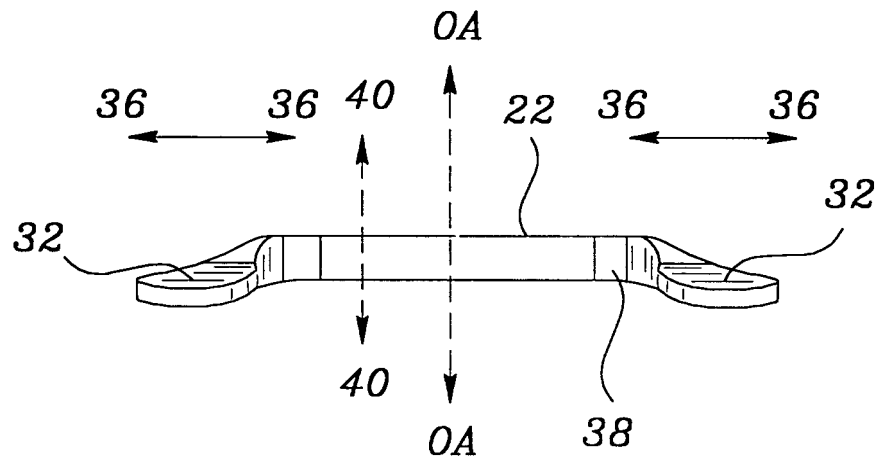

figure 12

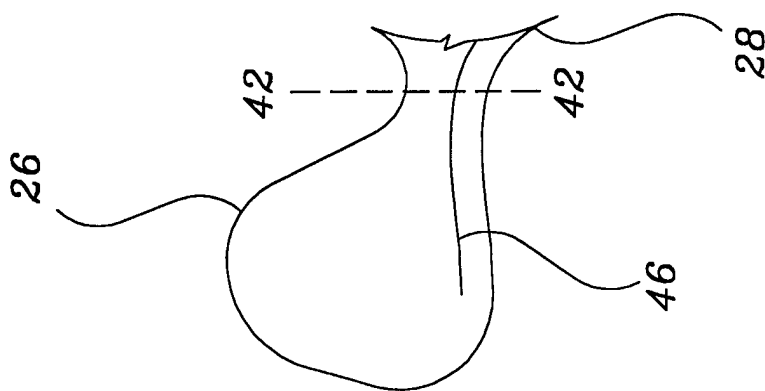

figure 13

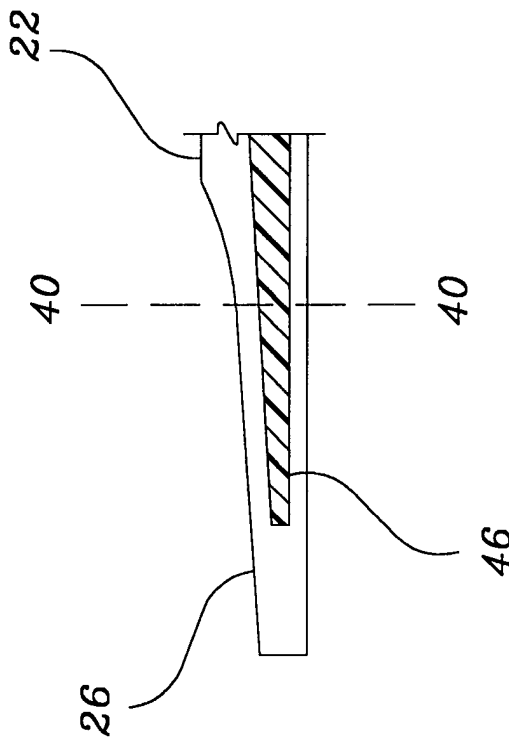

figure 14

INTERNATIONAL SEARCH REPORT

Intern: al Application No
PCT/US 98/12259

A. CLASSIFICATION OF SUBJECT MATTER

IPC 6 A61F2/16

According to International Patent Classification(IPC) or to both national classification and IPC

B. FIELDS SEARCHED

Minimum documentation searched (classification system followed by classification symbols)

IPC 6 A61F

Documentation searched other than minimum documentation to the extent that such documents are included in the fields searched

Electronic data base consulted during the international search (name of data base and, where practical, search terms used)

C. DOCUMENTS CONSIDERED TO BE RELEVANT

Category	Citation of document, with indication, where appropriate, of the relevant passages	Relevant to claim No.
A	WO 95 07059 A (IOVISION) 16 March 1995 see abstract see page 4, line 16 - line 29 see page 24, line 22 - line 31 see page 41, line 30 - page 43, line 6 ---	1-3,5,9, 11
A	WO 97 17915 A (W.K. ET ASSOCIES) 22 May 1997 see claim 7; figures ---	1-3,5,11
A	DE 42 11 265 C (ADATOMED) 29 July 1993 see column 4, line 32 - line 43; figures ---	1,12
A	GB 2 085 731 A (J.L. TENNANT) 6 May 1982 --- -/--	

Further documents are listed in the continuation of box C.

Patent family members are listed in annex.

° Special categories of cited documents :

- "A" document defining the general state of the art which is not considered to be of particular relevance
- "E" earlier document but published on or after the international filing date
- "L" document which may throw doubts on priority claim(s) or which is cited to establish the publication date of another citation or other special reason (as specified)
- "O" document referring to an oral disclosure, use, exhibition or other means
- "P" document published prior to the international filing date but later than the priority date claimed

- "T" later document published after the international filing date or priority date and not in conflict with the application but cited to understand the principle or theory underlying the invention
- "X" document of particular relevance; the claimed invention cannot be considered novel or cannot be considered to involve an inventive step when the document is taken alone
- "Y" document of particular relevance; the claimed invention cannot be considered to involve an inventive step when the document is combined with one or more other such documents, such combination being obvious to a person skilled in the art.
- "&" document member of the same patent family

Date of the actual completion of the international search

14 October 1998

Date of mailing of the international search report

21/10/1998

Name and mailing address of the ISA

European Patent Office, P.B. 5818 Patentlaan 2
 NL - 2280 HV Rijswijk
 Tel. (+31-70) 340-2040, Tx. 31 651 epo nl,
 Fax: (+31-70) 340-3016

Authorized officer

Wolf, C

INTERNATIONAL SEARCH REPORT

Intern ial Application No PCT/US 98/12259

C.(Continuation) DOCUMENTS CONSIDERED TO BE RELEVANT		
Category	Citation of document, with indication, where appropriate, of the relevant passages	Relevant to claim No.
A	EP 0 599 457 A (IOLAB CORPORATION) 1 June 1994 see abstract -----	14
A	US 5 180 390 A (R.C.DREWS) 19 January 1993 see abstract see column 3, line 49 - column 4, line 4; figures 4,5 -----	15
A	WO 87 01931 A (M.J. TILLAY) 9 April 1987 see page 10, line 30 - page 11, line 13; figures 14,16 see page 25, line 1 - line 10 -----	15,18

INTERNATIONAL SEARCH REPORT

information on patent family members

International Application No

PCT/US 98/12259

Patent document cited in search report	Publication date	Patent family member(s)	Publication date
WO 9507059 A	16-03-1995	AU 7641494 A	27-03-1995
WO 9717915 A	22-05-1997	FR 2740969 A EP 0863730 A	16-05-1997 16-09-1998
DE 4211265 C	29-07-1993	AT 146667 T CA 2093097 A DE 59304849 D EP 0563602 A ES 2098572 T JP 6277242 A	15-01-1997 04-10-1993 06-02-1997 06-10-1993 01-05-1997 04-10-1994
GB 2085731 A	06-05-1982	NONE	
EP 599457 A	01-06-1994	CA 2107189 A GR 93100386 A JP 6189986 A US 5693093 A US 5755786 A	29-03-1994 31-05-1994 12-07-1994 02-12-1997 26-05-1998
US 5180390 A	19-01-1993	NONE	
WO 8701931 A	09-04-1987	US 4666445 A EP 0238634 A	19-05-1987 30-09-1987