



INTERNATIONAL APPLICATION PUBLISHED UNDER THE PATENT COOPERATION TREATY (PCT)

<p>(51) International Patent Classification ⁶ : H04R 31/00</p>	<p>A1</p>	<p>(11) International Publication Number: WO 99/65277</p> <p>(43) International Publication Date: 16 December 1999 (16.12.99)</p>
<p>(21) International Application Number: PCT/DK99/00315</p> <p>(22) International Filing Date: 10 June 1999 (10.06.99)</p> <p>(30) Priority Data: PA 1998 00791 11 June 1998 (11.06.98) DK</p> <p>(71) Applicant (for all designated States except US): MICROTROTRONIC A/S [DK/DK]; Byleddet 12-14, DK-4000 Roskilde (DK).</p> <p>(72) Inventors; and (75) Inventors/Applicants (for US only): MÜLLENBORN, Matthias [DE/DK]; Lyngby Rosenvænge 23, DK-2800 Lyngby (DK). ROMBACH, Pirmin [DE/DK]; Engelsborgvej 25, st. th., DK-2800 Lyngby (DK).</p> <p>(74) Agent: HOFMAN-BANG & BOUTARD, LEHMANN & REE A/S; Hans Bekkevolds Allé 7, DK-2900 Hellerup (DK).</p>		<p>(81) Designated States: AE, AL, AM, AT, AT (Utility model), AU, AZ, BA, BB, BG, BR, BY, CA, CH, CN, CU, CZ, CZ (Utility model), DE, DE (Utility model), DK, DK (Utility model), EE, EE (Utility model), ES, FI, FI (Utility model), GB, GD, GE, GH, GM, HR, HU, ID, IL, IN, IS, JP, KE, KG, KP, KR, KZ, LC, LK, LR, LS, LT, LU, LV, MD, MG, MK, MN, MW, MX, NO, NZ, PL, PT, RO, RU, SD, SE, SG, SI, SK, SK (Utility model), SL, TJ, TM, TR, TT, UA, UG, US, UZ, VN, YU, ZA, ZW, ARIPO patent (GH, GM, KE, LS, MW, SD, SL, SZ, UG, ZW), Eurasian patent (AM, AZ, BY, KG, KZ, MD, RU, TJ, TM), European patent (AT, BE, CH, CY, DE, DK, ES, FI, FR, GB, GR, IE, IT, LU, MC, NL, PT, SE), OAPI patent (BF, BJ, CF, CG, CI, CM, GA, GN, GW, ML, MR, NE, SN, TD, TG).</p> <p>Published <i>With international search report.</i> <i>Before the expiration of the time limit for amending the claims and to be republished in the event of the receipt of amendments.</i></p>
<p>(54) Title: A METHOD OF MANUFACTURING A TRANSDUCER HAVING A DIAPHRAGM WITH A PREDETERMINED TENSION</p>		
<p>(57) Abstract</p> <p>A method of manufacturing a transducer of the type having a diaphragm (11) with a predetermined tension. After the transducer has been manufactured with its basic structure the diaphragm is adjusted to have a predetermined tension, which is preferably low in order to obtain a high sensitivity. Two embodiments are disclosed. One embodiment includes heating the transducer to a temperature above the glass transition temperature of the material (12, 14) retaining the diaphragm. Another embodiment includes measuring the actual tension of the diaphragm, which can be used to calculate an adjustment of the thickness of the diaphragm resulting in the desired tension.</p>		

FOR THE PURPOSES OF INFORMATION ONLY

Codes used to identify States party to the PCT on the front pages of pamphlets publishing international applications under the PCT.

AL	Albania	ES	Spain	LS	Lesotho	SI	Slovenia
AM	Armenia	FI	Finland	LT	Lithuania	SK	Slovakia
AT	Austria	FR	France	LU	Luxembourg	SN	Senegal
AU	Australia	GA	Gabon	LV	Latvia	SZ	Swaziland
AZ	Azerbaijan	GB	United Kingdom	MC	Monaco	TD	Chad
BA	Bosnia and Herzegovina	GE	Georgia	MD	Republic of Moldova	TG	Togo
BB	Barbados	GH	Ghana	MG	Madagascar	TJ	Tajikistan
BE	Belgium	GN	Guinea	MK	The former Yugoslav Republic of Macedonia	TM	Turkmenistan
BF	Burkina Faso	GR	Greece			TR	Turkey
BG	Bulgaria	HU	Hungary	ML	Mali	TT	Trinidad and Tobago
BJ	Benin	IE	Ireland	MN	Mongolia	UA	Ukraine
BR	Brazil	IL	Israel	MR	Mauritania	UG	Uganda
BY	Belarus	IS	Iceland	MW	Malawi	US	United States of America
CA	Canada	IT	Italy	MX	Mexico	UZ	Uzbekistan
CF	Central African Republic	JP	Japan	NE	Niger	VN	Viet Nam
CG	Congo	KE	Kenya	NL	Netherlands	YU	Yugoslavia
CH	Switzerland	KG	Kyrgyzstan	NO	Norway	ZW	Zimbabwe
CI	Côte d'Ivoire	KP	Democratic People's Republic of Korea	NZ	New Zealand		
CM	Cameroon			PL	Poland		
CN	China	KR	Republic of Korea	PT	Portugal		
CU	Cuba	KZ	Kazakistan	RO	Romania		
CZ	Czech Republic	LC	Saint Lucia	RU	Russian Federation		
DE	Germany	LI	Liechtenstein	SD	Sudan		
DK	Denmark	LK	Sri Lanka	SE	Sweden		
EE	Estonia	LR	Liberia	SG	Singapore		

A METHOD OF MANUFACTURING A TRANSDUCER HAVING A DIAPHRAGM WITH A PREDETERMINED TENSION

This invention concerns a method of manufacturing a
5 transducer having a diaphragm with a predetermined ten-
sion such as a microphone. Most microphones have a dia-
phragm which is caused to move by the sound pressure such
as microphones with electrodynamic, piezoelectric, piezo-
resistive, or capacitive readout. The method of the in-
10 vention applies to all such types of transducers having a
diaphragm.

In particular, a condenser microphone has as its basic
components a diaphragm or membrane mounted in close prox-
15 imity of a back plate. The diaphragm is retained along
its periphery and can move or deflect in response to a
sound pressure acting on a surface of the diaphragm. To-
gether the diaphragm and the back plate form an electric
capacitor, and when the diaphragm is deflected due to the
20 sound pressure, the capacitance of the capacitor will
vary. In use the capacitor will be charged with an elec-
tric charge corresponding to a DC voltage, and when the
capacitance varies in response to the varying sound pres-
sure, an electric AC voltage corresponding to the varying
25 sound pressure will be superimposed on the DC voltage.
This AC voltage is used as the output signal from the mi-
crophone.

A diaphragm with a low tension is "soft" and will deflect
30 more than a diaphragm with a high tension, resulting in a
higher sensitivity, which is desirable. The diaphragm of
a microphone of the type considered should therefore have
a well defined low tension.

Micromachined microphones have been developed by different research laboratories with applications such as in the telecommunication and hearing industry markets. One of the most challenging problems in the design and manufacturing of micromachined microphones is the controlled low tension of the diaphragm. Different sound detection principles have been suggested such as capacitive, piezoelectric, piezoresistive, optical, and tunneling read out. Most of which require a diaphragm with a tension below 50 N/m. In particular, battery-operated capacitive microphones with a low bias voltage of a few volts require very accurate control of the stress level in the diaphragm.

Conventionally, a diaphragm is glued to a metal frame using weights at the rim of the frame to adjust the tension of the diaphragm. This technique is not applicable to micromachining technology.

In micro-technology the tension of the diaphragm can be adjusted by developing new materials (e.g. silicon-rich silicon nitride), new deposition techniques (e.g. Plasma-Enhanced Chemical Vapor Deposition), new deposition conditions (e.g. by varying the temperature in a Low Pressure Chemical Vapor Deposition furnace), or subsequent temperature treatments (annealing treatments). Also the suspension of the diaphragm can relax tension e.g. through corrugations, hinges, springs, or in the most extreme case by suspending a plate.

However, the techniques currently used in micro-technology are either not reproducible and controllable enough for microphones in the above mentioned applications, or they impose other technological difficulties such as bending of suspensions and diaphragm due to a stress profile/gradient in the diaphragm.

Sensors and Actuators A. 31, 1992, 90-96 describes a transducer with a composite membrane consisting of two layers having compressive and tensile internal stress, respectively. It is described that by varying the relative thickness of the layers, the resulting internal stress can be controlled, but no method or means for doing so is disclosed.

10 This invention proposes a new method which can be used to tune the diaphragm stress to a predetermined level during or after processing of a micromachined microphone.

The diaphragm of the microphone resulting from the process of this invention is a sandwich of two or more layers (multi-layer, laminate, or composite) deposited on a rigid or stiff substrate. The diaphragm is formed by etching a hole into the substrate leaving the multi-layer as the diaphragm across the etched hole. In general, the layers of the diaphragm have different stress levels such as a layer of compressively stressed material and a layer of tensile stressed material, but the layers can both have compressive stress or tensile stress. This allows to achieve a desired tension level (tension = stress * thickness) by choosing the right ratio of the thicknesses of these materials. A thicker tensile layer will shift the total tension of the diaphragm to more tension, while a thicker compressively stressed material will shift the stress to more compression.

30 By adjusting the thickness ratio of the layers by the method according to the invention the tension can be controlled much more accurately than by any other attempt to achieve a certain stress or tension level, because thickness can be controlled almost down to the atomic level in micro-technology. It allows to deposit layers in a stable

regime, where the materials have little variations in their mechanical properties. The correct stress level is adjusted by choosing the correct mixture of materials rather than the correct materials properties. Furthermore, the total thickness of the diaphragm can be chosen independently of the stress/tension level.

The total stress can be changed after deposition of the layers by changing the thickness of one or both of the outer layers. This can be done by known methods such as dry or wet etching to remove material from the outer layers, or by deposition/absorption of material to achieve thicker outer layers. Deposition on or etching of the outer layers will change the ratio of thickness. The stress or tension level of the composite diaphragm will thereby change. Etching processes can be wet etching processes using reactants such as HF, phosphoric acid, KOH, etc. or dry etching processes such as Reactive Ion Etching. Low etching rates can easily be achieved to support a controlled, accurate, and uniform removal of material. Deposition processes for tuning include physical and chemical vapor deposition.

The processes used for batch manufacturing of transducers according to the invention are very accurate and reproducible, and within one batch transducers can be manufactured with very small deviations between transducers in the same batch. This means that, with the claimed method, it is not necessary to measure the actual diaphragm tension on each individual transducer before adjusting the tension. It suffices to measure the actual diaphragm tension on selected transducers on selected wafers in the batch, and with sufficiently precise and predictable processes it is even not necessary to measure the actual diaphragm tension of transducers in every batch.

The resulting diaphragms can be applied in many types of transducers such as condenser and other microphones, and specifically, in micromachined microphones based on semiconductor technology, in microphones in battery-operated equipment, sensitive microphones, and microphones with a high signal-to-noise ratio.

In the following the invention will be explained by way of example with reference to the figures in which

10

Figure 1 is a cross section through a condenser microphone, and

Figure 2 shows schematically the microphone of figure 1 during the process of adjusting the thickness of the diaphragm.

The microphone in figure 1 has the following structure. A substrate 10 carries a diaphragm or membrane 11 by means of an intermediate spacer 12 between the substrate 10 and the diaphragm 11. On the opposite side of the diaphragm a back plate 13 is situated with an intermediate spacer 14 between the back plate 13 and the diaphragm 11. The diaphragm 11 has three layers 11a, 11b and 11c.

25

The substrate 10 consists of bulk crystalline silicon and the backplate 13 consists of polycrystalline silicon. The spacers 12 and 14 consist of an electrically insulating material, which in this case is silicon dioxide SiO_2 . Of the three layers of the diaphragm, the intermediate layer 11b consists of polycrystalline silicon, and the two outer layers 11a and 11c consist of silicon nitride. The diaphragm 11 is thin and its tension is low so that it is "soft" and movable about the shown position, where it is in equilibrium.

35

The insulating spacer 14 provides an air gap 15 between the back plate 13 and the diaphragm 11, and the back plate 13 has a number of openings 16 giving access of sound to the air gap 15 and the diaphragm 11. On the opposite side of the diaphragm there is a back chamber 17, which is an opening in the substrate 10. If desired, the back chamber 17 can be connected to a further volume for acoustical purposes.

10 The diaphragm 11 and the back plate 13 are both electrically conductive, and together they form an electrical capacitor. Sound entering through the openings 16 in the back plate 13 will reach the diaphragm 11 and will cause it to move in response to the sound pressure. Thereby the
15 capacitance of the microphone will change correspondingly, since the air gap determines the capacitance. In operation the capacitor formed by the diaphragm 11 and the back plate 13 is charged with an electrical charge corresponding to a DC voltage, and when the capacitance
20 varies in response to the varying sound pressure, an electric AC voltage corresponding to the varying sound pressure will be superimposed on the DC voltage. This AC voltage is used as the output signal from the microphone.

25 The process for manufacturing a microphone with the structure shown in figure 1 and described above involves mainly known technology. The polycrystalline silicon is itself a semiconductor but can if desired be made conducting by doping with suitable impurities such as boron
30 (B) or phosphorus (P). The two outer layers 11a and 11c of the diaphragm consist of silicon nitride, which in combination with the B- or P-doped polycrystalline silicon in the intermediate layer of the diaphragm is particularly advantageous, as will be explained later.

As indicated in the figures, the intermediate layer 11b of the diaphragm consisting of B- or P- doped polycrystalline silicon has a compressive internal stress $\sigma < 0$, whereas the two outer layers 11a and 11c consisting of silicon nitride both have a tensile internal stress $\sigma > 0$, which need not be of the same size. The total or resulting tension of the diaphragm is the sum of the tension in the three layers 11a, 11b and 11c of the diaphragm. In each layer the stress is due to two factors. One factor is the technique used when depositing or building up the layer. This stress is called built-in stress. Another factor is the stress induced by a difference in thermal expansion coefficients of the different materials and is called thermal stress. Both stress contributions can be controlled, as will be explained in the following.

The built-in stress can be relieved by the following method. The spacer material retaining the diaphragm consists of silicon dioxide which is a glassy material having a glass transition temperature. By heating the individual microphone shown in figure 1 or rather the whole wafer including several identical microphones to a temperature above the glass transition temperature of the spacer material, the spacer material will become viscous and loose its stiffness. Therefore, in this state the tension in the diaphragm will become completely relieved, since the viscous spacer material can not transfer any strain. Following this the wafer is cooled. During cooling the spacer material will solidify and below the glass transition temperature the diaphragm will again become retained. During cooling below the glass transition temperature, due to thermal expansion and contraction, the diaphragm will regain some tension, which is due to the material properties, which is referred to above as thermal stress.

The thermal stress can be controlled by the following method. First, the actual tension and thickness of the diaphragm is measured and the actual stress calculated.

5 The desired tension is achieved by calculating the necessary thickness adjustment considering the actual stress. There are several useable methods of measuring the actual tension of the diaphragm.

10 One method of measuring the actual tension of the diaphragm is a test which involves pressurising the diaphragm of the microphone which causes the diaphragm to bulge, ie the diaphragm is given a unidirectional deflection. In practice this is done by pressurising a test
15 diaphragm on the wafer. Figure 2 shows a beam of light 18, and preferably a laser beam which is directed onto the test diaphragm. This is done in the unpressurised state and also in the pressurised state, and the laser beam 18 will be reflected from the surface of the dia-
20 phragm. The bulging of the diaphragm caused by the pressurisation can e.g. be registered by an auto-focus system. When the deflection of the diaphragm and the air pressure causing the bulging are known, the actual tension of the diaphragm can be calculated.

25

In another method of measuring the tension the diaphragm is excited thereby causing the diaphragm to oscillate. The excitation can be done either electrically or mechanically. When exciting the diaphragm with a pulse with
30 a short duration, the diaphragm will oscillate at its resonance frequency, which can be measured. The excitation signal can also be a sinusoidally oscillating force or voltage that is swept through the frequency range of interest for measuring the resonance frequency. When the
35 resonance frequency of the diaphragm is known, this can be used together with the other mechanical parameters of

the diaphragm such as its dimensions and material to calculate the actual tension of the diaphragm.

A third method for determining the tension uses test
5 structures on the wafer which work as strain gauges.

When the actual tension and thickness of the diaphragm is known the actual stress can be calculated. It can then be calculated how much the thickness of the diaphragm needs
10 to be adjusted in order to obtain the desired tension.

The microphone is preferably manufactured so that its diaphragm at this stage is too thick and therefore has a too high tension. From the above calculation of the desired thickness it is known how much material should be
15 removed in a subsequent etching process that can be either dry or wet etching. As shown in figure 3 the layer 11a having a tensile stress is etched. This is done by etching slowly in a well controlled process, until precisely so much of the layer 11a as needed according to
20 the calculation is removed by etching, and the diaphragm has obtained its predetermined tension.

If the diaphragm has a too low tension, extra material
25 having tensile stress can be deposited by known methods to obtain the predetermined tension.

Alternatively, if the diaphragm has only two layers with opposite internal stress, the layer having a compressive
30 stress can be etched in order to increase its tension.

In general, the tension of the diaphragm can by this method be shifted towards higher tension by etching a layer having relatively compressive stress or by deposit-
35 ing material having relatively tensile stress, and correspondingly, the tension of the diaphragm can be shifted

towards lower tension by etching a layer having relatively tensile stress or by depositing material having relatively compressive stress.

- 5 The above methods of relieving the material stress and of controlling the thermal stress can be performed independently of each other, and it is possible to use either of the methods alone ie without the other, or they can be used in combination.

Claims.

1. A method of manufacturing a micromachined transducer of the type having a diaphragm (11) and a substrate (10),
5 wherein the diaphragm (11) is retained in a predetermined position relative to the substrate (10) and spaced therefrom, in which position the diaphragm (11) is in equilibrium and has a predetermined tension allowing the diaphragm (11) to move about the position of equilibrium,
10 the method comprising the following steps:

providing the substrate (10),

15 providing the diaphragm (11) retained in the predetermined position relative to the substrate (10), and

in the predetermined position, adjusting the diaphragm (11) to have the predetermined tension.

20 2. A method according to claim 1 wherein the diaphragm is retained by means of a substance (12, 14) having a glass transition temperature, the method further comprising the step of heating the substance (12, 14) to a temperature of at least the glass transition temperature.

25

3. A method according to claim 2 wherein the substance (12, 14) having a glass transition temperature is SiO_2 .

4. A method according to claim 1 or 2 further comprising
30 the steps of

measuring the tension of the diaphragm (11), and

35 adjusting the thickness of the diaphragm (11) to a thickness resulting in the predetermined tension.

5. A method according to claim 4 wherein the thickness of the diaphragm (11) is adjusted by etching a surface of the diaphragm (11).

5

6. A method according to claim 4 wherein the thickness of the diaphragm (11) is adjusted by depositing material on a surface of the diaphragm (11).

10 7. A method according to claim 4 wherein the diaphragm (11) has at least two layers (11a, 11b, 11c) of different stress properties.

15 8. A method according to claim 7 wherein the diaphragm (11) has an intermediate layer (11b) consisting of polycrystalline silicon and outer layers (11a, 11c) consisting of silicon nitride on respective sides thereof.

20 9. A method according to claim 4 comprising the steps of pressurising the diaphragm (11) to deflect the diaphragm (11),

measuring the deflection of the diaphragm (11),

25

based on the measured deflection, calculating the tension of the diaphragm (11).

30 10. A method according to claim 9 wherein a beam of light (18) is directed onto the diaphragm and is reflected from the diaphragm, and the deflection of the diaphragm causes a change in the reflected beam of light (18), and based on the change of the beam of light (18) the deflection of the diaphragm is calculated.

35

11. A method according to claim 4 comprising the steps of

exciting the diaphragm (11) to vibrate,

measuring the resonance frequency of the diaphragm (11),

5

based on the measured resonance frequency, calculating
the tension of the diaphragm (11).

1/1

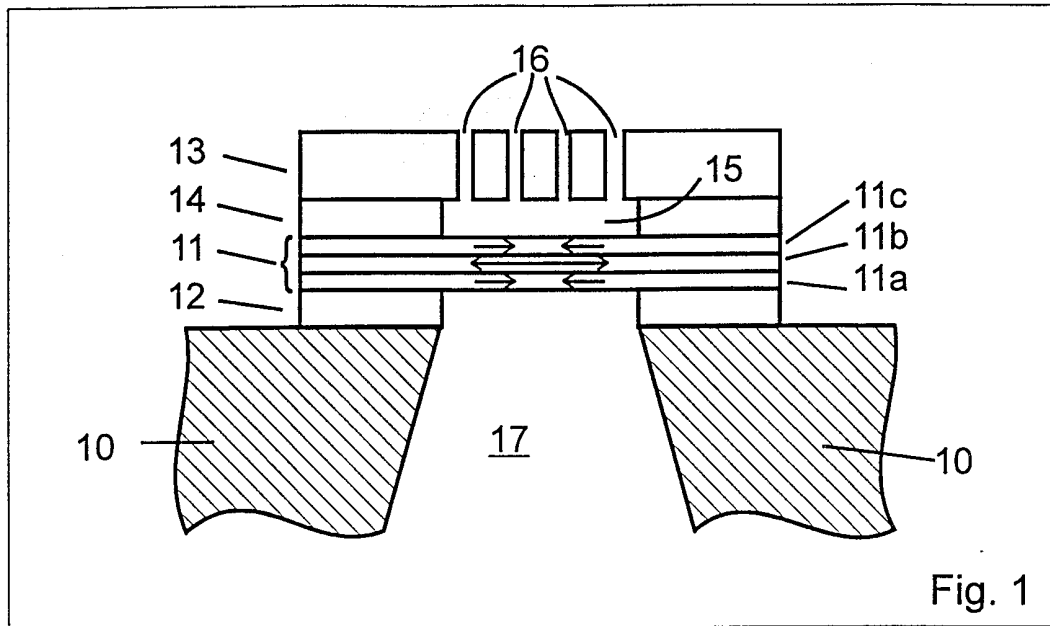

Fig. 1

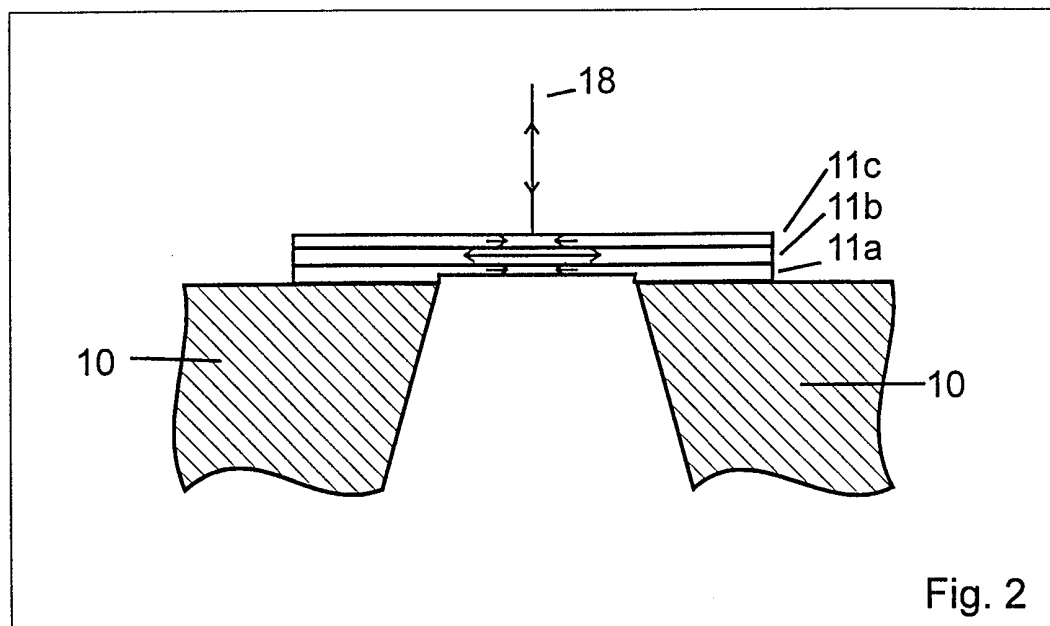

Fig. 2

INTERNATIONAL SEARCH REPORT

International application No.

PCT/DK 99/00315

A. CLASSIFICATION OF SUBJECT MATTER

IPC6: H04R 31/00

According to International Patent Classification (IPC) or to both national classification and IPC

B. FIELDS SEARCHED

Minimum documentation searched (classification system followed by classification symbols)

IPC6: H04R

Documentation searched other than minimum documentation to the extent that such documents are included in the fields searched

SE,DK,FI,NO classes as above

Electronic data base consulted during the international search (name of data base and, where practicable, search terms used)

C. DOCUMENTS CONSIDERED TO BE RELEVANT

Category*	Citation of document, with indication, where appropriate, of the relevant passages	Relevant to claim No.
A	WO 9739464 A1 (CALIFORNIA INSTITUTE OF TECHNOLOGY), 23 October 1997 (23.10.97) --	1
A	US 5408731 A (BERGGVIST ET AL), 25 April 1995 (25.04.95) --	1
A	US 4910840 A (SPRENKELS ET AL), 27 March 1990 (27.03.90) --	1
A	US 4764690 A (MURPHY ET AL), 16 August 1988 (16.08.88) --	1

 Further documents are listed in the continuation of Box C. See patent family annex.

* Special categories of cited documents:

"A" document defining the general state of the art which is not considered to be of particular relevance

"E" earlier document but published on or after the international filing date

"L" document which may throw doubts on priority claim(s) or which is cited to establish the publication date of another citation or other special reason (as specified)

"O" document referring to an oral disclosure, use, exhibition or other means

"P" document published prior to the international filing date but later than the priority date claimed

"T" later document published after the international filing date or priority date and not in conflict with the application but cited to understand the principle or theory underlying the invention

"X" document of particular relevance: the claimed invention cannot be considered novel or cannot be considered to involve an inventive step when the document is taken alone

"Y" document of particular relevance: the claimed invention cannot be considered to involve an inventive step when the document is combined with one or more other such documents, such combination being obvious to a person skilled in the art

"&" document member of the same patent family

Date of the actual completion of the international search

8 October 1999

Date of mailing of the international search report

16 -10- 1999

Name and mailing address of the ISA/

Swedish Patent Office

Box 5055, S-102 42 STOCKHOLM

Facsimile No. +46 8 666 02 86

Authorized officer

Lena Nilsson / JA A

Telephone No. +46 8 782 25 00

INTERNATIONAL SEARCH REPORT

International application No.

PCT/DK 99/00315

C (Continuation). DOCUMENTS CONSIDERED TO BE RELEVANT

Category*	Citation of document, with indication, where appropriate, of the relevant passages	Relevant to claim No.
A	US 4524247 A (LINDENBERGER ET AL), 18 June 1985 (18.06.85) --	1
A	US 4429192 A (BUSCH-VISHNIAC ET AL), 31 January 1984 (31.01.84) --	1
A	US 4014091 A (KODERA ET AL), 29 March 1977 (29.03.77) --	1
A	US 3924324 A (KODERA), 9 December 1975 (09.12.75) --	1
A	US 3660736 A (IGARASHI ET AL), 2 May 1972 (02.05.72) -- -----	1

INTERNATIONAL SEARCH REPORT

Information on patent family members

International application No.

30/08/99

PCT/DK 99/00315

Patent document cited in search report	Publication date	Patent family member(s)	Publication date
WO 9739464 A1	23/10/97	AU 2923397 A	07/11/97
US 5408731 A	25/04/95	AT 157837 T DE 69313583 D,T DK 596456 T EP 0596456 A,B FR 2697675 A,B JP 6217396 A	15/09/97 02/04/98 14/04/98 11/05/94 06/05/94 05/08/94
US 4910840 A	27/03/90	GB 2212026 A,B NL 8702589 A US 4908805 A	12/07/89 16/05/89 13/03/90
US 4764690 A	16/08/88	NONE	
US 4524247 A	18/06/85	NONE	
US 4429192 A	31/01/84	CA 1186047 A DE 3242554 A FR 2517161 A,B GB 2110054 A,B JP 58096497 A NL 8204512 A SE 453349 B,C SE 8206383 A	23/04/85 26/05/83 27/05/83 08/06/83 08/06/83 16/06/83 25/01/88 21/05/83
US 4014091 A	29/03/77	CA 970884 A JP 48031933 A JP 51021334 B	08/07/75 26/04/73 01/07/76
US 3924324 A	09/12/75	CA 1008187 A DE 2432377 A,C FR 2236259 A,B GB 1445943 A JP 1109589 C JP 50025677 A JP 56050408 B NL 181062 B,C NL 7409136 A	05/04/77 23/01/75 31/01/75 11/08/76 13/08/82 18/03/75 28/11/81 02/01/87 07/01/75
US 3660736 A	02/05/72	DE 2111215 A,B,C FR 2084449 A GB 1333847 A JP 50019183 B	23/09/71 17/12/71 17/10/73 04/07/75