

(12) STANDARD PATENT
(19) AUSTRALIAN PATENT OFFICE

(11) Application No. **AU 2010328454 B2**

- (54) Title
Surgical stapler with discrete staple height adjustment and tactile feedback
- (51) International Patent Classification(s)
A61B 17/072 (2006.01) **A61B 17/29** (2006.01)
A61B 17/115 (2006.01) **A61B 19/00** (2006.01)
- (21) Application No: **2010328454** (22) Date of Filing: **2010.12.06**
- (87) WIPO No: **WO11/071793**
- (30) Priority Data
- | | | |
|-------------------|-------------------|--------------|
| (31) Number | (32) Date | (33) Country |
| 12/635,415 | 2009.12.10 | US |
- (43) Publication Date: **2011.06.16**
(44) Accepted Journal Date: **2013.10.17**
- (71) Applicant(s)
Ethicon Endo-Surgery, Inc.
- (72) Inventor(s)
Zingman, Aron O.
- (74) Agent / Attorney
Freehills Patent Attorneys, Level 43 101 Collins Street, Melbourne, VIC, 3000
- (56) Related Art
EP 0639349
US 5915616



(51) International Patent Classification:

A61B 17/115 (2006.01) A61B 17/29 (2006.01)
A61B 19/00 (2006.01) A61B 17/072 (2006.01)

(21) International Application Number:

PCT/US2010/059034

(22) International Filing Date:

6 December 2010 (06.12.2010)

(25) Filing Language:

English

(26) Publication Language:

English

(30) Priority Data:

12/635,415 10 December 2009 (10.12.2009) US

(71) Applicant (for all designated States except US):
ETHICON ENDO-SURGERY, INC. [US/US]; 4545
Creek Road, Cincinnati, OH 45242 (US).

(72) Inventor; and

(75) Inventor/Applicant (for US only): **ZINGMAN, Aron, O.**
[US/US]; 2333 Salutaris Avenue, Cincinnati, OH 45206
(US).

(74) Agents: **JOHNSON, Philip, S.** et al.; Johnson & Johnson,
1 Johnson & Johnson Plaza, New Brunswick, NJ
08933 (US).

(81) Designated States (unless otherwise indicated, for every
kind of national protection available): AE, AG, AL, AM,
AO, AT, AU, AZ, BA, BB, BG, BH, BR, BW, BY, BZ,
CA, CH, CL, CN, CO, CR, CU, CZ, DE, DK, DM, DO,
DZ, EC, EE, EG, ES, FI, GB, GD, GE, GH, GM, GT,
HN, HR, HU, ID, IL, IN, IS, JP, KE, KG, KM, KN, KP,

KR, KZ, LA, LC, LK, LR, LS, LT, LU, LY, MA, MD,
ME, MG, MK, MN, MW, MX, MY, MZ, NA, NG, NI,
NO, NZ, OM, PE, PG, PH, PL, PT, RO, RS, RU, SC, SD,
SE, SG, SK, SL, SM, ST, SV, SY, TH, TJ, TM, TN, TR,
TT, TZ, UA, UG, US, UZ, VC, VN, ZA, ZM, ZW.

(84) Designated States (unless otherwise indicated, for every
kind of regional protection available): ARIPO (BW, GH,
GM, KE, LR, LS, MW, MZ, NA, SD, SL, SZ, TZ, UG,
ZM, ZW), Eurasian (AM, AZ, BY, KG, KZ, MD, RU, TJ,
TM), European (AL, AT, BE, BG, CH, CY, CZ, DE, DK,
EE, ES, FI, FR, GB, GR, HR, HU, IE, IS, IT, LT, LU,
LV, MC, MK, MT, NL, NO, PL, PT, RO, RS, SE, SI, SK,
SM, TR), OAPI (BF, BJ, CF, CG, CI, CM, GA, GN, GQ,
GW, ML, MR, NE, SN, TD, TG).

Declarations under Rule 4.17:

- as to the identity of the inventor (Rule 4.17(i))
- as to applicant's entitlement to apply for and be granted a patent (Rule 4.17(ii))
- as to the applicant's entitlement to claim the priority of the earlier application (Rule 4.17(iii))

Published:

- with international search report (Art. 21(3))
- before the expiration of the time limit for amending the claims and to be republished in the event of receipt of amendments (Rule 48.2(h))

(88) Date of publication of the international search report:
28 July 2011

(54) Title: SURGICAL STAPLER WITH DISCRETE STAPLE HEIGHT ADJUSTMENT AND TACTILE FEEDBACK

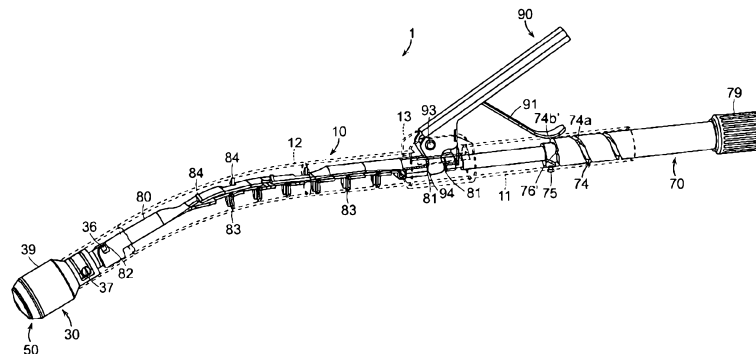

FIG. 4

(57) Abstract: In various embodiments, a surgical stapler (1) is provided that may comprise a body (10), a stapling head (30) operably coupled to the body, an anvil (50) movably supported relative to the stapling head for selective travel toward and away from the stapling head, and an anvil adjustment shaft (70) supported by the body for selectively adjusting a position of the anvil relative to the stapling head. The adjustment shaft and/or the body may be configured to establish at least one predetermined staple forming height between the anvil and the stapling head irrespective of adjustment shaft rotation. Additionally, the adjustment shaft and/or the body may be configured to provide tactile feedback to a user rotating the anvil adjustment shaft, thereby providing the user of an indication of when an appropriate staple forming height has been reached. Various integrations of components described herein may also reduce the part count required for a surgical stapler, thereby reducing assembly time and manufacturing cost.

WO 2011/071793 A3

TITLE

SURGICAL STAPLER WITH DISCRETE STAPLE HEIGHT ADJUSTMENT AND TACTILE
FEEDBACK

BACKGROUND

[0001] The embodiments relate, in general, to surgical staplers, and, more particularly, to a circular stapler including a discrete staple height adjustment.

[0002] In certain types of surgical procedures, the use of surgical staples has become the preferred method of joining tissue and, as such, specially configured surgical staplers have been developed for these applications. For example, intra-luminal or circular staplers have been developed for use in a surgical procedure known as an anastomosis. Circular staplers useful for performing an anastomosis are disclosed, for example, in U.S. Pat. Nos. 5,104,025; 5,205,459; 5,285,945; and 5,309,927, and in U.S. Patent Application Serial No.12/408,905, which are each herein incorporated by reference in their respective entireties.

[0003] One form of an anastomosis comprises a surgical procedure wherein sections of intestine are joined together after a diseased portion has been excised. The procedure requires re-joining the ends of the two tubular sections together to form a continuous tubular pathway. Previously, this surgical procedure was a laborious and time consuming operation. The surgeon had to precisely cut and align the ends of the intestine and maintain the alignment while joining the ends with numerous suture stitches. The development of circular staplers has greatly simplified the anastomosis procedure and also decreased the time required to perform an anastomosis.

[0004] In general, a conventional circular stapler typically consists of an elongated shaft that has a proximal actuating mechanism and a distal stapling mechanism mounted to the shaft. The distal stapling mechanism commonly consists of a fixed stapling cartridge that contains a plurality of staples configured in a concentric circular array. A round cutting knife is concentrically mounted in the cartridge interior to the staples for axial travel therein. Extending axially from the center of the cartridge is a movable trocar shaft that is adapted to have a staple anvil removably coupled thereto. The anvil is configured to form the ends of the staples as they are driven into it. The distance between a distal face of the staple cartridge and the staple anvil is controlled by an adjustment mechanism mounted to the proximal end of the stapler shaft for controlling the axial movement of the trocar. Tissue clamped between the staple cartridge and the staple anvil is simultaneously stapled and cut when the actuating mechanism is activated by the surgeon.

[0005] Generally, in the performance of a surgical anastomotic stapling operation, two pieces of lumen or tubular tissue, e.g., intestinal tissue, are attached together by a ring of staples. The two pieces of tubular tissue may be attached end to end or one piece of tubular tissue may be attached laterally around an opening formed in the side of another piece of tubular tissue. In performing the anastomosis with a stapling instrument, the two pieces of tubular tissue are clamped together between the anvil and the staple cartridge. A staple pusher is advanced to drive the staples into the tissue and form the staples against the anvil. Also, the circular knife is advanced to cut the excess tissue clamped between the anvil and the staple holder. As a result, a donut-shaped section of tissue is severed from each lumen and remains on the anvil shaft. The tubular tissue joined by the circular ring of staples is unclamped by advancing the anvil shaft distally to move the anvil away from the staple holder. The stapling instrument is removed by

pulling the anvil through the circular opening between the pieces of tubular tissue attached by the ring of staples.

[0006] Further, when performing a lower colon procedure using a circular stapler, the intestine is typically stapled using a conventional surgical stapler with double rows of staples being emplaced on either side of the diseased portion of intestine to be removed. The target section is simultaneously cut as the adjoining end is stapled. After removing the diseased portion, the surgeon typically inserts the anvil into the proximal end of the lumen, proximal of the staple line. This is done by inserting the anvil head into an entry port cut into the proximal lumen by the surgeon. On occasion, the anvil can be placed transanally, by placing the anvil head on the distal end of the stapler and inserting the instrument through the rectum. The surgeon then ties the proximal end of the intestine to the anvil shaft using a suture or other conventional tying device. Next, the surgeon cuts excess tissue adjacent to the tie and the surgeon attaches the anvil to the trocar shaft of the stapler. The surgeon then closes the gap between the anvil and cartridge, thereby clamping the proximal and distal ends of the intestine in the gap. The surgeon next actuates the stapler causing several rows of staples to be driven through both ends of the intestine and formed, thereby joining the ends and forming a tubular pathway. Simultaneously, as the staples are driven and formed, the concentric circular knife blade is driven through the intestinal tissue ends, cutting the ends adjacent to the inner row of staples. The surgeon then withdraws the stapler from the intestine and the procedure is complete.

[0007] During the above-described surgical procedures, it is desirable to properly form staples within a range of staple heights such that they are retained in the tissue and prevent leakage and bleeding and to achieve "tissue-to-tissue" contact which promotes tissue healing. In

2010328454 02 Sep 2013

general, by controlling the distance or gap between the anvil and the cartridge, better stapling and healing results may be achieved. While some surgical staplers are equipped with a visual readout indicating staple height, a surgeon may need to focus on many different items during surgery. Further, once the anvil has been properly positioned, it is necessary that the anvil not
5 move during firing, otherwise proper staple formation could be adversely affected.

[0008] The foregoing discussion is intended only to illustrate the present field and should not be taken as a disavowal of claim scope.

[0008a] Reference to any prior art in the specification is not, and should not be taken as, an acknowledgment, or any form of suggestion, that this prior art forms part of the common
10 general knowledge in Australia or any other jurisdiction or that this prior art could reasonably be expected to be ascertained, understood and regarded as relevant by a person skilled in the art.

[0008b] As used herein, the term “comprise” and variations of the term, such as “comprising”, “comprises” and “comprised”, are not intended to exclude other additives, components, integers or steps.

15 SUMMARY

[0009] In various embodiments, a surgical stapler is provided. In at least one embodiment, the surgical stapler can comprise a body, a stapling head assembly, a drive system, an anvil, and an anvil adjustment assembly. In these embodiments, the body can comprise a handle portion and a shaft portion extending from the handle portion. Further, in these
20 embodiments, the stapling head assembly can be releasably coupled to the shaft portion and the stapling head assembly can also comprise a staple cartridge for supporting one or more surgical staples, and at least one staple driver for engaging and driving the staples from the staple cartridge. Moreover, in these embodiments, the drive system may be configured to apply drive motions to the staple driver. Additionally, in these embodiments, the anvil may be movably
25 supported relative to the staple cartridge for axial movement toward and away from the staple cartridge. Also, in these embodiments, the anvil adjustment assembly may be configured to selectively adjust an axial position of the anvil relative to the staple cartridge. Further, in these embodiments, the anvil adjustment assembly can comprise an adjustment shaft and a trocar coupled to the adjustment shaft for travel therewith, and the trocar can be configured for
30 removable attachment to the anvil. Moreover, in these embodiments, one of the adjustment shaft or the body can comprise an engagement portion, and the other of the adjustment shaft or the body can comprise a screw surface including at least one ramp portion, at least one dwell portion, and at least one delimiter separating the at least one dwell portion from the at least one

2010328454 02 Sep 2013

ramp portion. Additionally, in these embodiments, the at least one ramp portion can be configured to operably engage the engagement portion to cause the adjustment shaft to move relative to the body when the adjustment shaft is rotated. Moreover, in these embodiments, the delimiter provides tactile feedback to the user as it passes over the engagement portion while the user rotates the adjustment shaft.

[0010] In at least one embodiment, a surgical stapler is provided that can comprise a body, a stapling head operably coupled to the body, an anvil movably supported relative to the stapling head for selective travel toward and away from the stapling head, and an anvil adjustment shaft supported by the body for selectively adjusting a position of the anvil relative to the stapling head. Further, in these embodiments, one of the adjustment shaft or the body can comprise an engagement portion, and the other of the adjustment shaft or the body can comprise a screw surface including a first portion and a second portion. Moreover, in these embodiments, the first portion can be configured to operably engage the engagement portion to cause the adjustment shaft to move relative to the body when the adjustment shaft is rotated. Additionally, in these embodiments, at least one delimiter can separate the first portion from the second portion, wherein the delimiter provides tactile feedback to the user as it passes over the engagement portion while the user rotates the anvil adjustment shaft.

[0011] In at least one embodiment, a surgical stapler is provided that can comprise a body, a stapling head operably coupled to the body, an anvil movably supported relative to the stapling head for selective travel toward and away from the stapling head, and an anvil adjustment shaft supported by the body for selectively adjusting a position of the anvil relative to the stapling head. Further, in these embodiments, one of the adjustment shaft or the body can comprise an engagement portion, and the other of the adjustment shaft or the body can comprise a screw surface including at least one ramp portion and at least one dwell portion. Moreover, in these embodiments, the at least one ramp portion can be configured to operably engage the engagement portion to cause the adjustment shaft to move relative to the body when the adjustment shaft is rotated. Additionally, in these embodiments, at least one delimiter can be located between the at least one ramp portion and the at least one dwell portion, wherein the delimiter provides tactile feedback to the user as it passes over the engagement portion while the user rotates the anvil adjustment shaft.

BRIEF DESCRIPTION OF THE FIGURES

2010328454 02 Sep 2013

5 [0012] The novel features of the embodiments described herein are set forth with particularity in the appended claims. The embodiments, however, both as to organization and methods of operation may be better understood by reference to the following description, taken in conjunction with the accompanying drawings as follows.

[0013] FIG. 1 is a perspective view of a non-limiting embodiment of a surgical stapler including a circular stapling head and an anvil in a first position.

10 [0014] FIG. 2 is a perspective view of the surgical stapler of FIG. 1 with the anvil shown in a second position.

[0015] FIG. 3 is an exploded view of the surgical stapler of FIG. 1.

[0016] FIG. 4 is a perspective view of the surgical stapler of FIG. 1 with a body of the stapler shown in dotted lines to better illustrate the stapler's components within the body.

[0017] FIG. 5 is a cross-sectional view of the surgical stapler of FIG. 1.

15 [0018] FIG. 6 is a rear perspective view of the anvil of the surgical stapler of FIG. 1.

[0019] FIG. 7A is a front perspective view of a stapling head assembly of the surgical stapler of FIG. 1.

[0020] FIG. 7B is a rear perspective view of a staple cartridge of the stapling head assembly of 7A; two staples are shown removed from staple cavities of the cartridge.

[0021] FIG. 7C is a front perspective view of a cutting member and staple drivers of the stapling head assembly of FIG. 7A.

[0022] FIG. 8 is a side view of an anvil adjustment shaft of the surgical stapler of FIG. 1.

[0023] FIG. 9 is a perspective view of a portion of the anvil adjustment shaft of FIG. 8.

[0024] FIGS. 10A-10C are a series of side views of a portion of the anvil adjustment shaft of FIG. 8, each showing a progression of a screw surface as the shaft is rotated about its longitudinal axis.

[0025] FIGS. 11A-11C are a series of side views of the anvil and the stapling head assembly of the surgical stapler of FIG. 1, each showing a discrete staple forming height correlating with the shaft positions shown in FIGS. 10A-10C, respectively.

[0026] FIG. 12 illustrates a non-limiting embodiment a portion of an anvil adjustment shaft including reference indicia.

[0027] FIG. 13 illustrates three reference indicia from the portion of the adjustment shaft of FIG. 12.

[0028] FIG. 14 is a rear perspective view of a trigger of the surgical stapler of FIG. 1; the trigger includes a lockout stem.

[0029] FIG. 15 is a front perspective view of a portion of the surgical stapler of FIG 3, showing the trigger and lockout stem interfacing with a drive band and the adjustment shaft, respectively.

[0030] FIG. 16 is a perspective view of a non-limiting embodiment of a surgical stapler including a straight shaft portion.

[0031] FIG. 17 is a side view of an anvil adjustment shaft of the surgical stapler of FIG. 16.

[0032] FIG. 18 is a perspective view of a drive bar of the surgical stapler of FIG. 16.

DETAILED DESCRIPTION

[0033] Certain embodiments will now be described to provide an overall understanding of the principles of the structure, function, manufacture, and use of the devices and methods disclosed herein. One or more examples of these embodiments are illustrated in the accompanying drawings. Those of ordinary skill in the art will understand that the devices and methods specifically described herein and illustrated in the accompanying drawings are non-limiting embodiments and that the scope of these embodiments is defined solely by the claims. The features illustrated or described in connection with one embodiment may be combined with the features of other embodiments. Further, where an ordering of steps in a process is indicated, such ordering may be rearranged or the steps may be carried out contemporaneously as desired unless illogical or the listed order is explicitly required. Such modifications and variations are intended to be included within the scope of the appended claims.

[0034] In the following description, like reference characters designate like or corresponding parts throughout the several views. Also in the following description, it is to be understood that terms such as "forward," "rearward," "front," "back," "right," "left," "over," "under," "upwardly," "downwardly," "proximally," "distally," and the like are words of convenience and are not to be construed as limiting terms. The description below is for the purpose of describing various embodiments and is not intended to limit the appended claims.

[0035] The various embodiments generally relate to various surgical staplers configured to seal tissue and, in at least one embodiment, cut tissue also. Such surgical staplers may be configured to function through a natural orifice, such as the anus, mouth and/or vagina, or through an incision cut through a body wall. Further, such surgical staplers may be designed as endoscopic tools, including laparoscopic tools.

[0036] Focusing now on one non-limiting embodiment, as can be seen in FIGS. 1-4, a circular stapler 1 is provided that includes a tubular or circular body 10, a stapling head 30 operably coupled to the body 10, an anvil 50, an anvil adjustment shaft 70 supported by the body 10, and a trigger 90 movably coupled to the body 10. The anvil 50 may be movably supported relative to the stapling head assembly for selective travel toward and away from the stapling head 30. Further, the anvil adjustment shaft 70 may be supported by the body 10 to selectively adjust a position of the anvil relative to the stapling head. Therefore, as will be explained in more detail below, the adjustment shaft 70 may be operably coupled to the anvil 50 to effect movement of the same. For example, the adjustment shaft 70 may be rotated, via a knob 79 of the adjustment shaft, about its longitudinal axis, in a first rotation direction, such as a clockwise “CW” direction, to cause the shaft 70 and the anvil 50 to move or translate in a distal direction “DD,” relative to the body 10, from a first position shown in FIG. 1 to a second position shown in FIG. 2. Likewise, the adjustment shaft 70 may be rotated in a second rotational direction, such as a counterclockwise “CCW” direction, to cause the shaft 70 and the anvil 50 to move or translate in a proximal direction “PD,” relative to the body 10, from the second position shown in FIG. 2 to the first position shown in FIG. 1. It is to be understood that the anvil 50 may be positioned anywhere between or outside the positions shown in FIGS. 1-2, as allowed by the surgical stapler 1. Further, in at least one embodiment, as explained in more detail below, the

adjustment shaft 70 may be configured to move the anvil 50 to at least one predetermined distance from the stapling head and/or to provide tactile feedback to a user.

[0037] When the trigger 90 is activated, a drive system may be actuated within the body 10 so that staples 31 (see FIGS. 3 and 7B) may be expelled from the stapling head 30 into forming contact with the anvil 50. Simultaneously, a cutting member 32 (see FIG. 7C), that is operably supported within the head 30, acts to cut tissue held within the circumference of the stapled tissue. The stapler 10 is then pulled through the tissue leaving stapled tissue in its place. Further, the trigger 90 may include a spring 91 extending from a lever 92 such that when lever 92 is squeezed or otherwise moved towards body 10 about hinge pin 93, the lever 91 is biased back away from the body 10 and the knife 70 is automatically retracted upon release of the lever 92.

[0038] Referring to FIG. 3, the body 10 may include a handle portion 11 and a curved shaft portion 12. While the present embodiment illustrates a curved shaft portion 12, the shaft portion may also be straight or linear (see, e.g., FIG. 16, discussed below). The handle portion 11 may be adapted to receive trigger 90 via a saddle attachment 13 that may further include holes 16 (see FIG. 3) with which to receive hinge pin 93 which may also be received in holes 96 of the trigger 90. The handle portion 11 may further define an opening 14 at the top of the body 10 through which a portion of the trigger 90 may be positioned. For example, cam surfaces 94 and a lockout stem 95 may extend through the opening 14. As will be explained in more detail below, cam surfaces 94 may be configured to actuate the drive system when the trigger 90 is moved relative to the handle portion 11, and the lockout stem 95 may prevent inadvertent firing of the cutting member 32 and/or staples 31 before the anvil 50 is in an appropriate position such that staples may be formed between the anvil 50 and the stapling head 30.

[0039] Referring to FIGS. 3 and 4, the drive system may comprise drive band 80 extending axially between the trigger's cam surfaces 94 and tabs 36 of the stapling head 30, within the body's shaft portion 12. Drive band 80 may include proximal drive surfaces 81 and distal drive surfaces 82. Thus actuation of the trigger may cause the cam surfaces 94 to rotate and push proximal drive surfaces 81 such that the drive band 80 moves in an axial direction towards or away from anvil 50. The stapling head's tabs 36 may be coupled within the drive band's distal drive surfaces 82, which may take the form of notches to releasably receive tabs 36.

[0040] Referring to FIGS. 4 and 7A-7C, the stapling head 30 may include an assembly comprising a staple cartridge 33 for supporting one or more staples 31, at least one staple driver 34 for engaging and driving the staples 31 from the cartridge 33, and a cutting member 32, e.g., a knife, movably supported in the stapling head 30. In at least one embodiment, the staple drivers 34 and the cutting member 32 may be integrally connected and/or formed. For example, the staple drivers 34 and cutting member 33 may extend from a core 35, each of which may be formed from the same material. In any event, actuation of the drive band 80 towards staple cartridge 33 and/or anvil 50 may cause the stapling head's tabs 36, which may extend from core 35, and, thus, the cutting member 32 and the staple drivers 34 to move towards anvil 50. Further, the stapling head 30 may also comprise a casing 39 that is configured to hold the staple cartridge 33 and movably receive the staple drivers 34, cutting member 32, and/or core 35 therethrough. The casing 39 may additionally include release buttons 37 that are configured to flexibly deflect and allow the stapling head 30 to be releasably attached to the body's shaft portion 12 at corresponding holes 15 (see FIG. 3) formed therein. Accordingly, referring to FIG. 4, the stapling head 30 may be removed by pressing on buttons 37, then turning the head 30 such

that tabs 36 are released from the notches formed by the distal driving surfaces 82 of the drive band 80, and finally pulling the stapling head 30 away from the body 10.

[0041] Focusing now on the adjustment of the anvil 50 and referring to FIG. 3, in various embodiments and as noted above, the anvil 50 may be movably supported relative to the staple cartridge 33 such that the anvil may be moved axially toward and away from the staple cartridge 33. In more detail, the surgical stapler 1 may comprise an anvil adjustment assembly for selectively adjusting an axial position of the anvil 50 relative to the staple cartridge 33. The anvil adjustment assembly may comprise adjustment shaft 70 and a trocar 73 coupled to the adjustment shaft 70 for travel therewith. The adjustment shaft 70 may comprise a proximal portion 70a and a distal portion 70b, which may be connected together to form shaft 70. Alternatively, proximal and distal portions 70a, 70b may be unitary and integrally formed from the same piece of material (see, e.g., adjustment shaft 170 depicted in FIG. 17 and discussed below). Additionally, the adjustment shaft 70 may further comprise an annular groove 71 located at distal portion 70b which may be clipped or otherwise freely connected to a proximal end of an anvil adjustment band 72. By freely connected, it is to be understood that the adjustment band 72 may not rotate while the adjustment shaft 70 rotates; however, the adjustment band 72 may still translate along with the shaft 70. A distal end of the adjustment band 72 may be also attached to trocar 73. Accordingly, axial movement or translation of adjustment shaft 70 with respect to body 10 may cause the trocar 73 to also axially move or translate with respect to body 10.

[0042] Referring to FIGS. 3 and 4, one or both of anvil adjustment band 72 and drive band 80 may include tabs 83 and 84, respectively, that are bent or otherwise projecting toward

body 10. Tabs 83, 84 may assist in allowing bands 72, 80 to travel through the body's curved shaft portion 12 while filling space and maintaining an appropriate axial position therein.

[0043] Further, referring to FIGS. 3 and 6, as is known in the field, the trocar 73 may be removably attached to the anvil 50 by leaf or spring clips 55 coupled to the anvil and/or trocar. In other words, the anvil may be removed from the trocar by pressing, pulling, or otherwise manipulating the spring clips 55. Contrarily, the trocar may be snapped into the anvil by moving the trocar into the anvil such that the spring clips 55 releasably hold the anvil on the trocar. Thus, axial movement of the anvil adjustment shaft 70 with respect to body 10 may also axially move or translate anvil 50 with respect to body 10. Further, the anvil may also include a shroud 53 coupled to an anvil body 52 (see FIG. 3) and a washer 54 that is sheared during firing of the cutting member 32, as discussed above. The washer 54 may be made of plastic and may serve as a cutting surface against which tissue may be severed.

[0044] Referring now to FIGS. 3-5, the anvil adjustment shaft 70 may be configured to be rotated, as explained above, such that the shaft 70 translates relative to the body 10. In more detail and in at least one embodiment, the anvil adjustment shaft 70 may comprise a screw surface 74 that operably engages an engagement portion of the body 10, such as a screw pin 75 fixed to the body 10 via a hole in the same. The screw surface 74 may be defined by a channel formed in adjustment shaft 70 that is sized and configured to receive at least a portion of pin 75 therein. The anvil adjustment shaft 70 may be rotated about its longitudinal axis L (see FIG. 8) such that the screw surface 74 contacts and is moved over the pin 75, thereby causing the anvil adjustment shaft 70 to translate with respect to the body 10. While pin 75 is described in the present embodiment, any other suitable thread mating portion or component, such as a protrusion, thread, and the like, may be used to engage the screw surface in place of or in

addition to pin 75. In any event, rotating the adjustment shaft 70 about its longitudinal axis may cause the shaft 70 and, hence, trocar 73 and anvil 50 to also translate or move axially with respect to body 10 and/or stapling head 30.

[0045] As mentioned above, in various embodiments, the adjustment shaft 70 may be configured to move the anvil 50 to at least one predetermined distance from the stapling head 30. In more detail, and focusing now on FIG. 8, which shows only the adjustment shaft 70, the adjustment shaft's screw surface 74 may include at least one ramp portion and at least one dwell portion. For example, the screw surface 74 may comprise a first, ramp portion 74a and a second, dwell portion or portions 74b. At least one delimiter, such as delimiter 76, may also separate the ramp portion 74a from the dwell portion 74b. As will be discussed in more detail below, the ramp portion 74a may allow the adjustment shaft to translate with respect to the body 10 (see FIG. 4), dwell portion 74b may provide a predetermined distance to maintain the position of the anvil 50 from the stapling head 30 (see FIG. 2), and the delimiter 76 may provide tactile feedback to a user rotating the anvil adjustment shaft 70 as well as a transition between the ramp and dwell portions. Further, in at least one embodiment, the ramp portion 74a may be at least partially helical in shape.

[0046] Continuing, the circle drawn in dashed lines in FIG. 8 represents the approximate portion of the anvil adjustment shaft 70 that is shown in FIGS. 9 and 10A-10C. Focusing now on FIG. 9, the ramp portion 74a of screw surface 74 may lead into at least one dwell portion. As illustrated and in at least one embodiment, the screw surface 74 may further comprise three dwell portions, first dwell portion 74b', second dwell portion 74b'', and third dwell portion 74b'''. Rotation of the anvil adjustment shaft 70 about its longitudinal axis may cause the screw surface 74 to pass along pin 75 (see FIG. 5) such that the shaft 70 translates with respect to the body 10

(again, see FIG. 5). Further, as the shaft 70 is rotated clockwise CW, for example, the screw surface 74 may move along pin 75 such that the pin 75 contacts the ramp portion and then the first dwell portion 74b'. Then, as the shaft 70 is again rotated clockwise CW, the pin may contact the second dwell portion 74b". Thereafter, additional rotation of the shaft 70 clockwise CW may cause the pin to contact the third dwell portion 74b"". As will be explained in more detail below, each dwell portion may be at a different angular configuration compared to the ramp portion 74a.

[0047] Further, each dwell portion 74b', 74b", and 74b"" may be at a different longitudinal position along anvil adjustment shaft 70 to provide predetermined, discrete staple forming heights. For example, referring to FIG. 10A, the first dwell portion 74b' may be at a first distance L_1 from a transverse ledge 77 of the shaft assembly. The second dwell portion 74b" may be at a second distance L_2 from the transverse ledge 77, and the third dwell portion 74b"" may be at a third distance L_3 from the transverse ledge 77. Any reference point or plane, including transverse ledge 77 may be used to establish the aforementioned distances. In any event, the first distance L_1 may be greater than the second distance L_2 , which may be greater than the third distance L_3 , or $L_1 > L_2 > L_3$. Alternatively, although now shown, the distances may be in other comparative orders, such as $L_1 > L_3 > L_2$, $L_2 > L_1 > L_3$, $L_2 > L_3 > L_1$, $L_3 > L_2 > L_1$, or $L_3 > L_1 > L_2$. Further, each of the dwell distances L_1 , L_2 , and L_3 may be uniform over their respective dwell portions 74b', 74b", and 74b"". In other words, referring to FIG. 10B, for example, while the screw surface's ramp portion 74a may slope at a ramp or helix angle α of less than 90 degrees relative to the adjustment shaft's longitudinal axis L, each dwell portion (e.g., 74b" in FIG. 10B) may be substantially perpendicular to the longitudinal axis L, or define an angle θ that is approximately 90 degrees with respect to the axis L. Further, referring to FIGS. 9

and 10A-10C, the dwell portions 74b', 74b'', 74b''' may otherwise be steps defining predetermined, discrete staple heights, as discussed below. When measuring the aforementioned angles with respect to longitudinal axis L, it should be understood that such measurements may be made with respect to a plane that is tangential to a portion of screw surface 74 and that plane's intersection with longitudinal axis L, which, for the purposes of clarity, is shown over the length of the anvil adjustment shaft shown in FIGS. 10A-10C. For example, referring to FIG. 10B again, helix angle α is defined between tangential plane "TP," that is perpendicular to the plane of the page of FIG. 10B, and longitudinal axis L.

[0048] Focusing now on FIGS. 11A-11C, the stapling head 30 and the anvil 50 are shown in various positions correlating with the dwell portions 74b', 74b'', and 74b''' of the shaft's screw surface. For example, discrete staple forming heights D_1 , D_2 , and D_3 may be defined between a staple forming surface 51 of anvil 50 and a staple ejection surface 38 of staple cartridge 33. The first height D_1 may be greater than the second height D_2 , which may be greater than the third distance D_3 , or $D_1 > D_2 > D_3$. Referring collectively to FIGS. 10A-10C and 11A-11C, each dwell portion 74b', 74b'', and/or 74b''' may allow the anvil 50 to be held at the respective staple forming height D_1 , D_2 , and/or D_3 while the adjustment shaft 70 is being rotated such that the a dwell portion moves along the pin 75 (see FIG. 5). For example, each dwell portion 74b', 74b'', 74b''' may be designed to maintain the anvil's position for a period of shaft rotation of about 60 degrees. In other words, an arc running along each dwell portion's surface may stretch over an angle of approximately 60 degrees.

[0049] Referring to FIGS. 9 and 10A-10C, in various embodiments, at least one transition may separate each dwell portion 74b', 74b'', and/or 74b''' to thereby enable the anvil adjustment shaft 70 to be advanced to another position relative to the pin 75 (see FIG. 5). In at

least one embodiment, the transition may comprise another ramp portion and/or a partial helical surface. However, in at least one other embodiment, the transition may also comprise at least one delimiter. As can be seen in FIGS. 10A-10C, a first delimiter 76' may separate the screw surface's ramp portion 74a from the first dwell portion 74b', a second delimiter 76" may separate the first dwell portion 74b' from the second dwell portion 74b", and a third delimiter 76''' may separate the second dwell portion 74b" from the third dwell portion 74b'''. As mentioned above, each delimiter 76', 76", and/or 76''' may provide tactile feedback to a user while the user rotates the anvil adjustment shaft.

[0050] In more detail, referring again to FIGS. 9 and 10A-10C, each delimiter 76', 76", and/or 76''' may comprise a bump or a protrusion in the screw surface. In other words, the screw surface 74 may define a surface topography including the ramp portion 74a and the dwell portions 74b', 74b", and 74b''', and each delimiter 76', 76", and/or 76''' may be an interruption in the surface topography, between the aforementioned portions, respectively. Also, with the exception of the delimiters 76', 76", and/or 76''', the surface topography over any portion of screw surface 74 may be smooth. For example, referring to FIGS. 5, 9, and 10A-10C, the screw surface's ramp portion 74a may include a smooth topography such that the screw surface 74 may move relatively smoothly past the pin 75 when the anvil adjustment shaft 70 is rotated with respect to body 10. However, when the pin 75 reaches the end of the ramp portion 74a, the surface topography may be interrupted by the first delimiter 76'. Accordingly, as the screw surface 74 is advanced over pin 75, the adjustment shaft 70, which may be extending proximally from body 10 in a smooth fashion as shaft 70 is being rotated, may jump, push, or pull in an abrupt or discontinuous fashion, or otherwise provide tactile feedback to a user, as the first delimiter 76' contacts the pin 75, owing to the interruption in the surface topography of the screw

surface 74 at the delimiter 76'. The action of the first delimiter 76' passing over the pin 75 may provide a user rotating the shaft 70 with an indication that the first discrete staple forming height D_1 (see FIG. 11A) has been reached as the pin 75 is now received at the first dwell portion 74b'. Continued rotation of shaft 70 for the dwell period, which, as mentioned above, may be approximately 60 degrees, may not adjust the first staple forming height D_1 . Accordingly, the user does not necessarily need to focus on the exact rotational position at which anvil adjustment shaft 70 is located, as long as the user knows that the first staple forming height D_1 will not change until the shaft 70 is further rotated to bring another delimiter into contact with the pin 75. Further, the user may rotate the anvil adjustment shaft 70 back and forth such that the pin 75 is relatively moved along first dwell portion 74b', between first delimiter 76' and second delimiter 76". As the delimiters protrude from the surface of first dwell portion 74b', the user, through the anvil adjustment shaft 70, may feel when the pin 75 contacts the first or second delimiter 76', 76" at the respective ends of first dwell portion 74b', thereby providing confidence to the user that the first staple forming height D_1 has been reached.

[0051] Referring to FIGS. 5, 9, and 10A-10C, if the user desires to change the staple forming height from the first staple forming height D_1 to the second staple forming height D_2 (see FIGS. 11A-11B), the user may further rotate the anvil adjustment shaft 70 such that the second delimiter 76" contacts the pin 75. When the pin 75 reaches the end of the first dwell portion 74b', the surface topography may be interrupted by the second delimiter 76". Accordingly, as the screw surface 74 is advanced over pin 75, the adjustment shaft 70, which may be rotating smoothly while the pin 75 is contacting the first dwell portion 74b', may jump, push, or pull in an abrupt or discontinuous fashion, or otherwise provide tactile feedback to a user, as the second delimiter 76" contacts the pin 75 owing to the interruption in the surface

topography of the screw surface 74 at the delimiter 76". The action of the second delimiter 76" passing over the pin 75 may provide a user rotating the shaft 70 with an indication that the second discrete staple forming height D_2 (see FIG. 11B) has been reached as the pin 75 is now received at the second dwell portion 74b". Continued rotation of shaft 70 for the dwell period, which, as mentioned above, may be approximately 60 degrees, may not adjust the second staple forming height D_2 . Accordingly, the user does not necessarily need to focus on the exact rotational position at which anvil adjustment shaft 70 is located, as long as the user knows that the second staple forming height D_2 will not change until the shaft 70 is further rotated to bring another delimiter into contact with the pin 75. Further, the user may rotate the anvil adjustment shaft 70 back and forth such that the pin 75 is relatively moved along second dwell portion 74b", between second delimiter 76" and third delimiter 76". As the delimiters protrude from the surface of second dwell portion 74b", the user, through the anvil adjustment shaft 70, may feel when the pin 75 contacts the second or third delimiter 76", 76" at the respective ends of second dwell portion 74b", thereby providing confidence to the user that the second staple forming height D_2 has been reached.

[0052] Similarly, referring still to FIGS. 5, 9, and 10A-10C, if the user desires to change the staple forming height from the second staple forming height D_2 to the third staple forming height D_3 (see FIGS. 11B-11C), the user may further rotate the anvil adjustment shaft 70 such that the third delimiter 76" contacts the pin 75. When the pin 75 reaches the end of the second dwell portion 74b", the surface topography may be interrupted by the third delimiter 76". Accordingly, as the screw surface 74 is advanced over pin 75, the adjustment shaft 70, which may be rotating smoothly while the pin 75 is contacting the second dwell portion 74b", may jump, push, or pull in an abrupt or discontinuous fashion, or otherwise provide tactile feedback

to a user, as the third delimiter 76''' contacts the pin 75, owing to the interruption in the surface topography of the screw surface 74 at the delimiter 76'''. The action of the third delimiter 76''' passing over the pin 75 may provide a user rotating the shaft 70 with an indication that the third discrete staple forming height D_3 (see FIG. 11C) has been reached as the pin 75 is now received at the third dwell portion 74b'''. Continued rotation of shaft 70 for the dwell period, which, as mentioned above, may be approximately 60 degrees, may not adjust the third staple forming height D_3 . Accordingly, the user does not necessarily need to focus on the exact rotational position at which anvil adjustment shaft 70 is located, as long as the user knows that the third staple forming height D_3 will not change until the shaft 70 is further rotated to bring a stop 78 into contact with the pin 75, thereby preventing further movement of the pin 75 relative to the screw surface 74, towards stop 78. The stop 78 may be a wall formed at the end of the third delimiter portion 74b'''. Further, the user may rotate the anvil adjustment shaft 70 back and forth such that the pin 75 is relatively moved along third dwell portion 74b''', between third delimiter 76''' and stop 78. As the stop and delimiter 76''' protrude from the surface of third dwell portion 74b''', the user, through the anvil adjustment shaft 70, may feel when the pin 75 contacts the third delimiter 76''' or stop 78 at the respective ends of third dwell portion 74b''', thereby providing confidence to the user that the third staple forming height D_3 has been reached.

[0053] In various embodiments, referring to FIGS. 9 and 15, for example, the screw surface 74 may be closed over the ramp portion 74a and open over the dwell portions 74b', 74b'', 74b'''. In other words, the screw surface's ramp portion may include proximal and distal walls whereas the screw surface's dwell portions may only include proximal walls. In use, the pin 75 may be biased against the dwell portions due to tissue being clamped between anvil 50 and

stapling head 30 when the anvil 50 is at an appropriate staple forming height from the head 30, as discussed above (see FIGS. 11A-11C).

[0054] While at least one embodiment described above show the delimiters 76', 76", and/or 76''' as being formed as bumps or protrusions in the screw surface 74, the delimiters may also take the form of indentations in the screw surface. Also, the delimiters may be a separate piece from the adjustment shaft 70 such that they may be attached thereto. In any event, the delimiters may provide tactile feedback to a user as the user rotates the shaft 70. Further, while a delimiter is shown as separating the ramp portion 74a from the first dwell portion 74b', and so on, the screw surface may not include a dwell portion or dwell portions. In such embodiments, the screw surface may comprise multiple ramp portions separated, at desired intervals, by at least one delimiter. Accordingly, a user may be informed, via tactile feedback, when an appropriate staple forming height, between the anvil 50 and staple cartridge 33 (see, e.g., FIG. 11A) has been obtained.

[0055] In addition to tactile feedback, the surgical stapler 1 may include visual reference indicia to provide a user with an indication of when the aforementioned staple forming height(s) have been reached. For example, referring now to FIGS. 12-13, the anvil adjustment shaft 70 may include reference indicia 85 printed or formed in the shaft's surface that, via a marking 86 on body 10, to provide an indication of when a discrete staple forming height, such as D_1 , D_2 , D_3 (see FIGS. 11A-11C), has been reached. In at least one embodiment, the respective staple forming heights may be 2.5mm, 1.8mm, and 1.0mm, and the reference indicia 85 may indicate the same. In any event, the incorporation of visual indicia, delimiters, and/or dwell portions, as discussed above, into the anvil adjustment shaft 70 may remove the need for a staple height indicator mechanism separate from the shaft.

[0056] Additionally, while at least one embodiment described above has illustrated the screw surface 74 as being defined by a channel formed in anvil adjustment shaft 70, the screw surface may, in at least one embodiment, alternatively be defined by a thread projecting from the anvil adjustment shaft 70. In such embodiments, pin 75 may be employed or another thread mating component may be used to engage the screw surface, such as a fork projecting from the inside of body 10.

[0057] Further, while the screw surface 74 discussed above is described as being a part of anvil adjustment shaft 70, it is to be understood that such screw surface could alternatively be a part of the body 10. In such embodiments, an engagement portion, such as a pin or other thread engaging component, would likewise be fixed to the adjustment shaft 70 instead of to the body 10. In any event, rotation of the shaft 70 may cause a screw surface to rotate with respect to an engagement portion such that the shaft 70 and, hence, the anvil 50 translate with respect to the body 10 and/or stapling head 30.

[0058] In various embodiments, as mentioned above and referring to FIG. 5, before the anvil 50 is at an appropriate distance from staple cartridge 33, the trigger 90 may cooperate with the adjustment shaft 70 to prevent the trigger 90 from moving substantially towards body 10 or otherwise causing staple drivers 34 and/or cutting member 32 to be actuated, thereby preventing the unintended firing of the surgical stapler 1. In other words, the trigger may include a lockout. For example, in at least one embodiment and referring to FIG. 8, the actuation shaft 70 may comprise the first, proximal portion 70a defining a first width W_1 , and the second, distal portion 70b defining a second width W_2 . Further, referring to FIG. 14, the trigger 90 may comprise lockout stem 95 extending from lever 92, the stem 95 defining an opening 97 having a size S. The lockout stem may resemble a fork with two tines, or a yoke. In any event, the size S of the

opening 97 may be smaller than the first width W_1 of the proximal portion 70a but the size S of the opening 97 may be larger than or equal to the second width W_2 of the distal portion 70b, or $W_1 > S \geq W_2$.

[0059] Referring now to FIG. 15, the lockout stem 95 may be positioned through body opening 14 such that the stem 95 is operable to engage either the shaft's proximal portion 70a or the shaft's distal portion 70b. If the lockout stem 95 is longitudinally positioned over the proximal portion 70a, the trigger lever 92 may be prevented from moving substantially towards body 10 due to interference between the lockout stem 95 and the shaft's proximal portion 70a. In other words, because the proximal portion's width W_1 (see FIG. 8) is larger than the size S of the lockout stem's opening 97 (see FIG. 14), the trigger lever 92 may be prevented from causing the drive band 80 to actuate, as described above, thereby preventing inadvertent firing of staples 31 and/or cutting member 32 (see FIG. 3). However, if the lockout stem 95 is longitudinally positioned over the distal portion 70b, the trigger lever 92 may be allowed to move substantially towards body 10 due to a lack of interference between the lockout stem 95 and the shaft's distal portion 70b. In other words, because the distal portion's width W_2 (see FIG. 8) is smaller than or equal to the size S of the lockout stem's opening 97 (see FIG. 14), the trigger lever 92 may be allowed to move and cause the drive band 80 to actuate, as described above, thereby firing staples 31 and/or cutting member 32 (see FIG. 3). In such embodiments, the opening 97 may receive the shaft's distal portion 70b and allow the lever 92 to move towards body 10 until the distal portion 70b reaches the end of opening 97.

[0060] Further, referring to FIG. 15, the shaft's distal portion 70b may be positioned along anvil adjustment shaft 70 such that the distal portion 70b correlates with an appropriate staple forming height. For example, the distal portion 70b may be axially positioned along shaft

70 such that the lockout stem 95 is longitudinally positioned over the distal portion 70b when the pin 75 is received in a dwell portion, such as first dwell portion 74b'. Accordingly, the lockout stem 95 may only allow the staple drivers 34 and/or cutting member 32 (see FIG. 3) to be fired when a desired staple forming height has been reached, without the need for a lockout lever or mechanism separate from the trigger 90. Further, referring to FIG. 14, the lockout stem 95 may be unitary and integrally formed from the same piece of material as trigger spring 91. However, in at least one embodiment, the lockout stem 95, trigger spring 91, and lever 92 may be unitary and integrally formed from the same piece of material.

[0061] In various embodiments, and as mentioned above, the surgical stapler may be straight instead of curved, as described above. Accordingly, referring now to FIG. 16, a surgical stapler 101 is shown. Surgical stapler 101 may include a body 110, a stapling head 130, an anvil 150, an anvil adjustment shaft 170, and a trigger 190, similar to that described above. However, shaft portion 112 of body 110 may be straight. Further, the stapling head 130 and anvil 150 may be linear and project axially away from the body 110. It should be noted that, referring to the surgical staplers 1 and 101 depicted in FIGS. 1 and 16, respectively, because each stapling head 30, 130 may be removed from the surgical stapler's body 10, 110 as discussed above, the stapling heads 30, 130 and anvils 50, 150 may be interchanged with each other, for example. Further, other stapling head and anvil configurations may be employed in addition to the above describe heads 30, 130 and anvils 50, 150.

[0062] Also, referring now to FIG. 17, the anvil adjustment shaft 170 and trocar 173 may be unitary and integrally formed from the same piece of material. Thus, the shaft's distal portion 170b may project from the proximal portion 170a and abut the trocar 173. Further, referring to FIG. 18, a drive bar 180 is shown. Drive bar may allow movement of trigger 190 (see FIG. 16)

to actuate drive bar 180 towards stapling head 130 to eject staples and/or actuate a cutting member (not shown) therefrom. Briefly, the drive bar may be elongate and generally tubular in shape and include proximal drive surfaces 181 and distal drive surfaces 182. Referring to FIGS. 16 and 18, the proximal drive surfaces 181 may be configured to receive driving motions from trigger 190 and the distal drive surfaces 182 may be configured to engage staple drivers and/or a cutting member (not shown) within stapling head 130, as described above. Also, the drive bar 180 may include a passage 187 adapted to receive anvil adjustment shaft 170 (see FIG. 17) therethrough. In at least one embodiment, the stapler 101 may not include a cutting member, and may primarily function to staple or seal, but not transect, tissue.

[0063] It should be appreciated that the straight stapler 101 and the curved stapler 1, discussed above (see FIGS. 16 and 1, respectively) may contain significantly fewer components than similar current surgical staplers available on the market. For example, referring to straight surgical stapler 101, and in particular to anvil adjustment shaft, the combination of a knob 179, with a closure screw or screw surface 174, and trocar 173 into one integral component, anvil adjustment shaft 170, reduces part count of a surgical stapler. Further reducing component count may be obtained by combining a ramp portion 174a with a dwell portion 174b into screw surface 174. As discussed above, the screw surface's ramp portion 174a may allow initial, coarse axial movement of shaft 170 with respect to body 110, and the dwell portion(s) 174b may establish at least one discrete, predetermined staple forming height between anvil 150 and stapling head 130. Overall, ignoring the anvil and stapling head components, the surgical stapler 101 may include only seven components compared to over thirty in current devices. Referring to FIGS. 16-18, the seven components may include the body 110, the firing trigger 190, a hinge pin 193 pivotally coupling the trigger 190 to the body 110, a trigger spring 191 integrally formed with a

lockout stem 195, the anvil adjustment shaft 170, a screw pin (not shown, see screw pin 75 seen in FIG. 3, for example) operably engaging the shaft's screw surface 174, and the drive bar 180. Additionally, the part count may be further reduced. For example, the hinge pin 193 may be eliminated by combining a hinge detent or flexible tab, for example, into the trigger 190 itself. Further, spring 191 and lockout stem 195 may also be integrally formed with the trigger 190. Also, the screw pin (not shown) may be eliminated by incorporating a protrusion extending from an inner surface of body 110 such that the screw protrusion may engage the screw surface 174. In any event, the aforementioned components of surgical stapler 101 may provide similar functionality as that described above. This simplified stapler architecture using only a few manufacturing techniques may be broadly applicable, and should be appropriate for a multi-use, sterilizable device, that costs significantly less and requires less manufacturing time than similar, currently available surgical staplers. Accordingly, in at least one embodiment, a stapler, including the above-mentioned components, less the anvil and stapling head parts, may be provided that is reusable. Also, in at least one embodiment, the anvil and/or stapling head, including a staple cartridge, may further be disposable.

[0064] In at least one exemplary experiment, the aforementioned minimization of part count was accomplished by comparing each component to a part criteria list to see if that part was needed. The only ones remaining were those listed above and required for assembly reasons, possessed unique material properties, or which moved with respect to other parts in the stapler.

[0065] While the embodiments have been described, it should be apparent, however, that various modifications, alterations and adaptations to the embodiments may occur to persons skilled in the art with the attainment of some or all of the advantages of the various

embodiments. For example, according to various embodiments, a single component or step may be replaced by multiple components or steps, and multiple components or steps may be replaced by a single component or step, to perform a given function or functions or accomplish a given objective. Further, the various components described above may be made from a variety of materials. For example, the components may be made from any combination of metal, plastic, and/or a biocompatible material. Moreover, various components, such as the trigger, drive band, and anvil adjustment band may be made and bent or folded from sheet metal. This application is therefore intended to cover all such modifications, alterations and adaptations without departing from the scope and spirit of the appended claims.

[0066] The devices disclosed herein can be designed to be disposed of after a single use, or they can be designed to be used multiple times. In either case, however, the devices can be reconditioned for reuse after at least one use. Reconditioning can include a combination of the steps of disassembly of the device, followed by cleaning or replacement of particular pieces, and subsequent reassembly. In particular, the devices can be disassembled, and any number of particular pieces or parts of the device can be selectively replaced or removed in any combination. Upon cleaning and/or replacement of particular parts, the devices can be reassembled for subsequent use either at a reconditioning facility, or by a surgical team immediately prior to a surgical procedure. Those of ordinary skill in the art will appreciate that the reconditioning of a device can utilize a variety of different techniques for disassembly, cleaning/replacement, and reassembly. Use of such techniques, and the resulting reconditioned device, are all within the scope of the present application.

[0067] The devices described herein may be processed before surgery. First a new or used instrument is obtained and, if necessary, cleaned. The instrument can then be sterilized. In

one sterilization technique, the instrument is placed in a closed and sealed container, such as a plastic or TYVEK® bag. The container and instrument are then placed in a field of radiation that can penetrate the container, such as gamma radiation, x-rays, or higher energy electrons. The radiation kills bacteria on the instrument and in the container. The sterilized instrument can then be stored in the sterile container. The sealed container keeps the instrument sterile until it is opened in the medical facility.

[0068] Any patent, publication, or other disclosure material, in whole or in part, that is said to be incorporated by reference herein is incorporated herein only to the extent that the incorporated material does not conflict with existing definitions, statements, or other disclosure material set forth in this disclosure. As such, and to the extent necessary, the disclosure as explicitly set forth herein supersedes any conflicting material incorporated herein by reference. Any material, or portion thereof, that is said to be incorporated by reference herein, but which conflicts with existing definitions, statements, or other disclosure material set forth herein will only be incorporated to the extent that no conflict arises between that incorporated material and the existing disclosure material.

2010328454 02 Sep 2013

THE CLAIMS DEFINING THE INVENTION ARE AS FOLLOWS:

1. A surgical stapler, comprising:

a body comprising:

a handle portion; and

5 a shaft portion extending from the handle portion;

a stapling head assembly releasably coupled to the shaft portion, the stapling head assembly comprising:

a staple cartridge for supporting one or more surgical staples; and

10 at least one staple driver for engaging and driving the staples from the staple cartridge;

a drive system for applying drive motions to the staple driver;

an anvil movably supported relative to the staple cartridge for axial movement toward and away from the staple cartridge; and

15 an anvil adjustment assembly for selectively adjusting an axial position of the anvil relative to the staple cartridge, wherein the anvil adjustment assembly comprises an adjustment shaft and a trocar coupled to the adjustment shaft for travel therewith, the trocar configured for removable attachment to the anvil, wherein one of the adjustment shaft or the body comprises an engagement portion, and wherein the other of the adjustment shaft or the body comprises:

20 a screw surface comprising at least one ramp portion, at least one dwell portion, and at least one delimiter separating the at least one dwell portion from the at least one ramp portion, the at least one ramp portion configured to operably engage the engagement portion to cause the adjustment shaft to move relative to the body when the adjustment shaft is rotated; and

25 wherein the delimiter provides tactile feedback to the user as it passes over the engagement portion while the user rotates the adjustment shaft.

2. The surgical stapler of claim 1, further comprising a trigger movably coupled to the body, the trigger configured to actuate the drive system when the trigger is moved, wherein the adjustment shaft comprises a first portion defining a first width and a second portion defining a

2010328454 02 Sep 2013

second width, wherein the trigger further comprises a lockout stem defining an opening having a size, wherein the size of the opening is smaller than the first width but the opening is larger than or equal to the second width.

3. The surgical stapler of claim 1, wherein the at least one delimiter is a bump.

5 4. The surgical stapler of claim 1, wherein the at least one delimiter is a protrusion.

5. The surgical stapler of any one of the preceding claims, wherein the screw surface defines a surface topography, and wherein the at least one delimiter is an interruption in the surface topography.

10 6. The surgical stapler of any one of the preceding claims, wherein the at least one ramp portion slopes at an angle of less than 90 degrees relative to the adjustment shaft's axis and the at least one dwell portion is substantially perpendicular to the adjustment shaft's axis.

7. The surgical stapler of any one of the preceding claims, further comprising visual indicia on the anvil adjustment shaft correlating with the at least one dwell portion.

8. A surgical stapler, comprising:

15 a body;

a stapling head operably coupled to the body;

an anvil movably supported relative to the stapling head for selective travel toward and away from the stapling head; and

20 an anvil adjustment shaft supported by the body for selectively adjusting a position of the anvil relative to the stapling head, wherein one of the anvil adjustment shaft or the body comprises an engagement portion, and wherein the other of the anvil adjustment shaft or the body comprises:

25 a screw surface comprising a first portion and a second portion, the first portion configured to operably engage the engagement portion to cause the anvil adjustment shaft to move relative to the body when the anvil adjustment shaft is rotated; and

2010328454 02 Sep 2013

at least one delimiter separating the first portion from the second portion, wherein the delimiter provides tactile feedback to the user as it passes over the engagement portion while the user rotates the anvil adjustment shaft.

9. The surgical stapler of claim 8, wherein the at least one delimiter is a bump.

10. The surgical stapler of claim 8, wherein the at least one delimiter is a protrusion.

11. The surgical stapler of any one of claims 8 to 10, wherein the screw surface defines a surface topography, and wherein the at least one delimiter is an interruption in the surface topography.

12. The surgical stapler of any one of claims 8 to 11, wherein the first portion slopes at an angle of less than 90 degrees relative to the anvil adjustment shaft's axis and the second portion is substantially perpendicular to the anvil adjustment shaft's axis.

13. The surgical stapler of any one of claims 8 to 12, further comprising a drive system configured to eject staples from the stapling head and a trigger movably coupled to the body, the trigger configured to actuate the drive system when the trigger is moved, wherein the anvil adjustment shaft comprises a first portion defining a first width and a second portion defining a second width, wherein the trigger further comprises a lockout stem defining an opening having a size, wherein the size of the opening is smaller than the first width but the opening is larger than or equal to the second width.

14. A surgical stapler, comprising:

a body;

a stapling head operably coupled to the body;

an anvil movably supported relative to the stapling head for selective travel toward and away from the stapling head; and

an anvil adjustment shaft supported by the body for selectively adjusting a position of the anvil relative to the stapling head, wherein one of the adjustment shaft or the body comprises an engagement portion, and wherein the other of the adjustment shaft or the body comprises:

a screw surface comprising at least one ramp portion and at least one dwell portion, the at least one ramp portion configured to operably engage the engagement

2010328454 02 Sep 2013

portion to cause the adjustment shaft to move relative to the body when the adjustment shaft is rotated; and

at least one delimiter between the at least one ramp portion and the at least one dwell portion, wherein the delimiter provides tactile feedback to the user as it passes over the engagement portion while the user rotates the anvil adjustment shaft.

15. The surgical stapler of claim 14, wherein the at least one ramp portion slopes at an angle of less than 90 degrees relative to the adjustment shaft's axis and the at least one dwell portion is substantially perpendicular to the adjustment shaft's axis.

16. The surgical stapler of claim 14, wherein the at least one delimiter is a bump.

17. The surgical stapler of claim 14, wherein the at least one delimiter is a protrusion.

18. The surgical stapler of any one of claims 14 to 17, wherein the screw surface defines a surface topography, and wherein the at least one delimiter is an interruption in the surface topography.

19. The surgical stapler of any one of claims 14 to 18, further comprising a drive system configured to eject staples from the stapling head and a trigger movably coupled to the body, the trigger configured to actuate the drive system when the trigger is moved, wherein the adjustment shaft comprises a first portion defining a first width and a second portion defining a second width, wherein the trigger further comprises a lockout stem defining an opening having a size, wherein the size of the opening is smaller than the first width but the opening is larger than or equal to the second width.

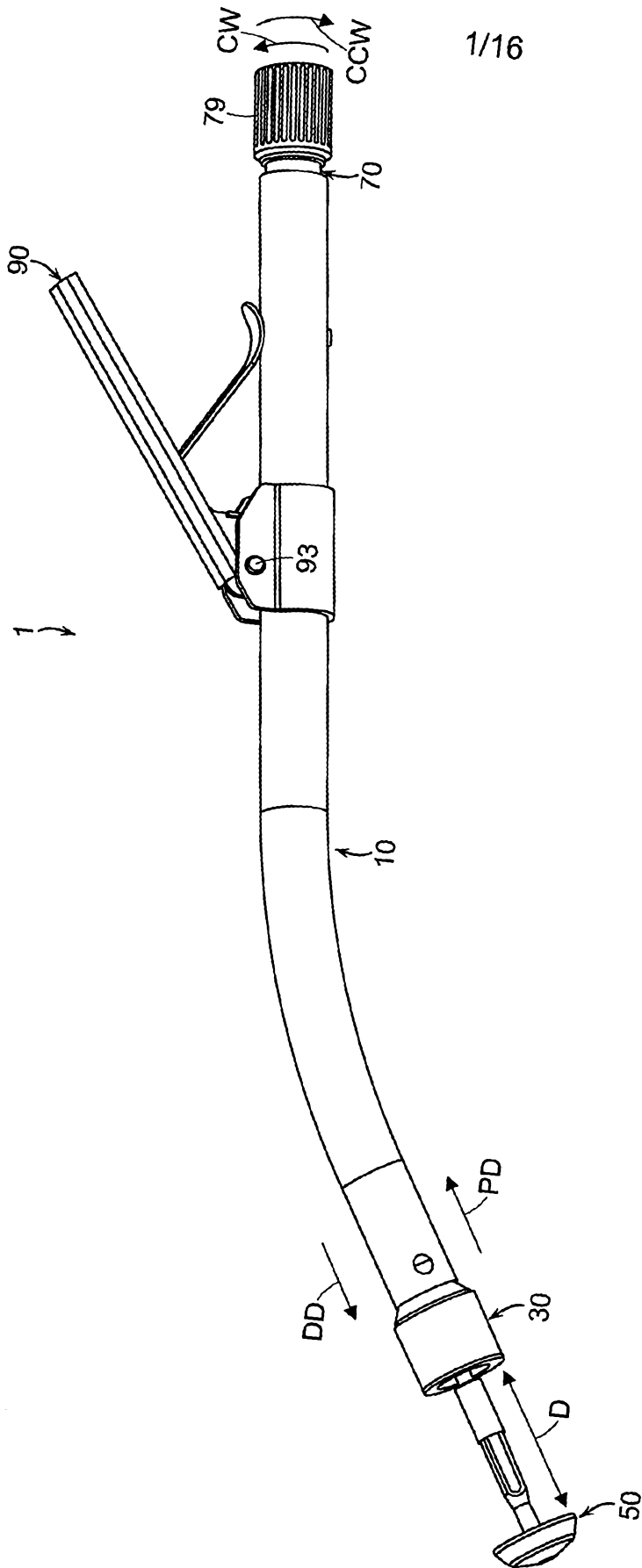

FIG. 1

2/16

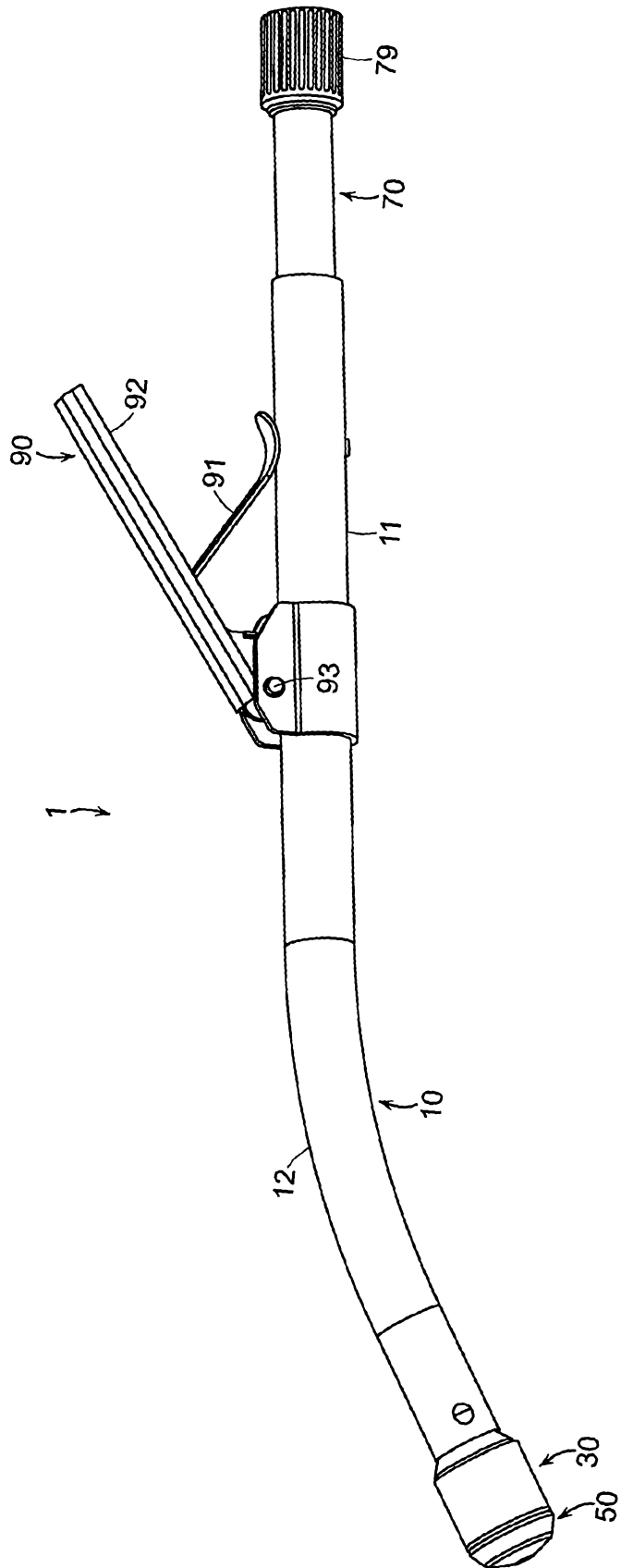

FIG. 2

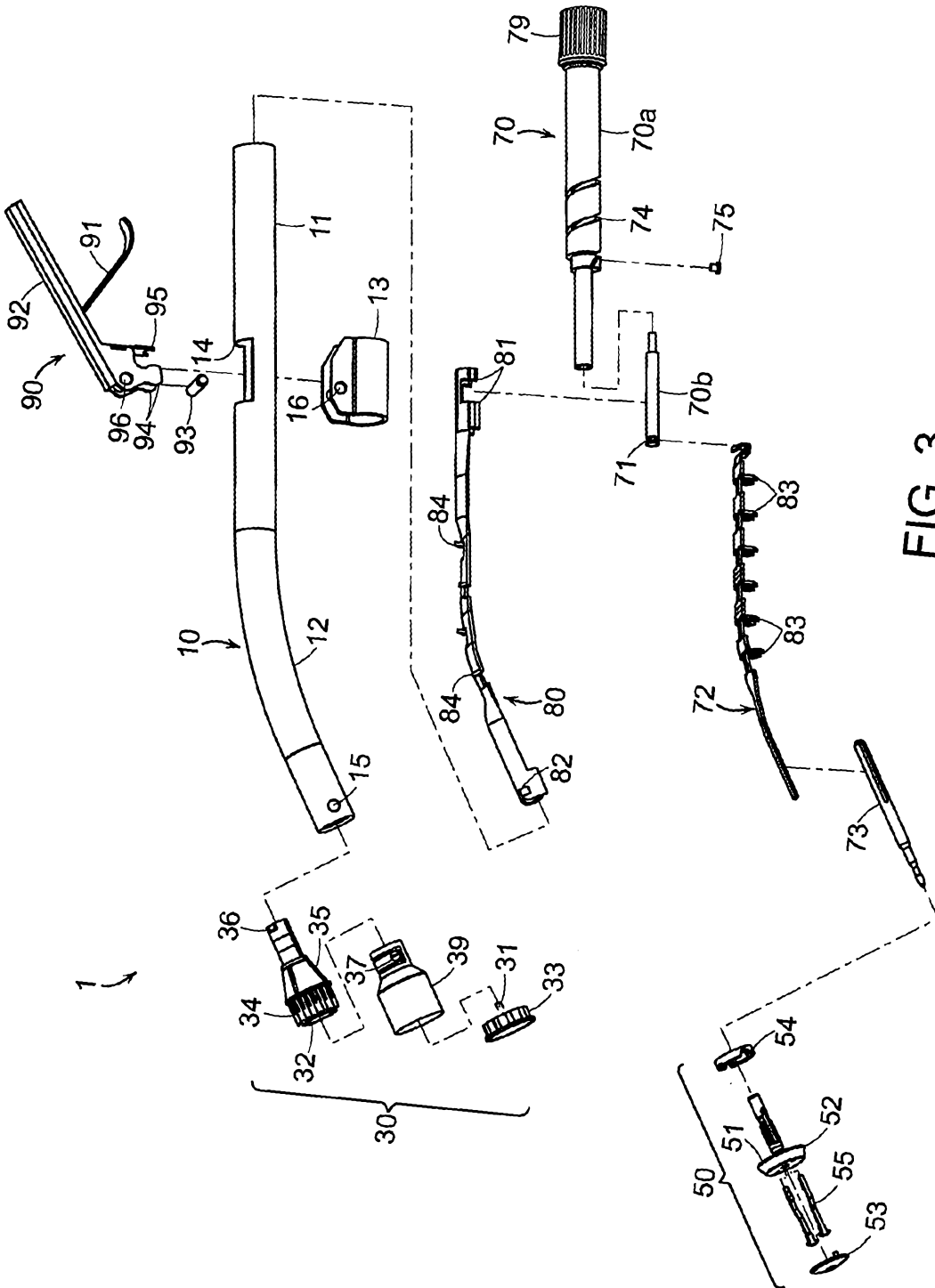

FIG. 3

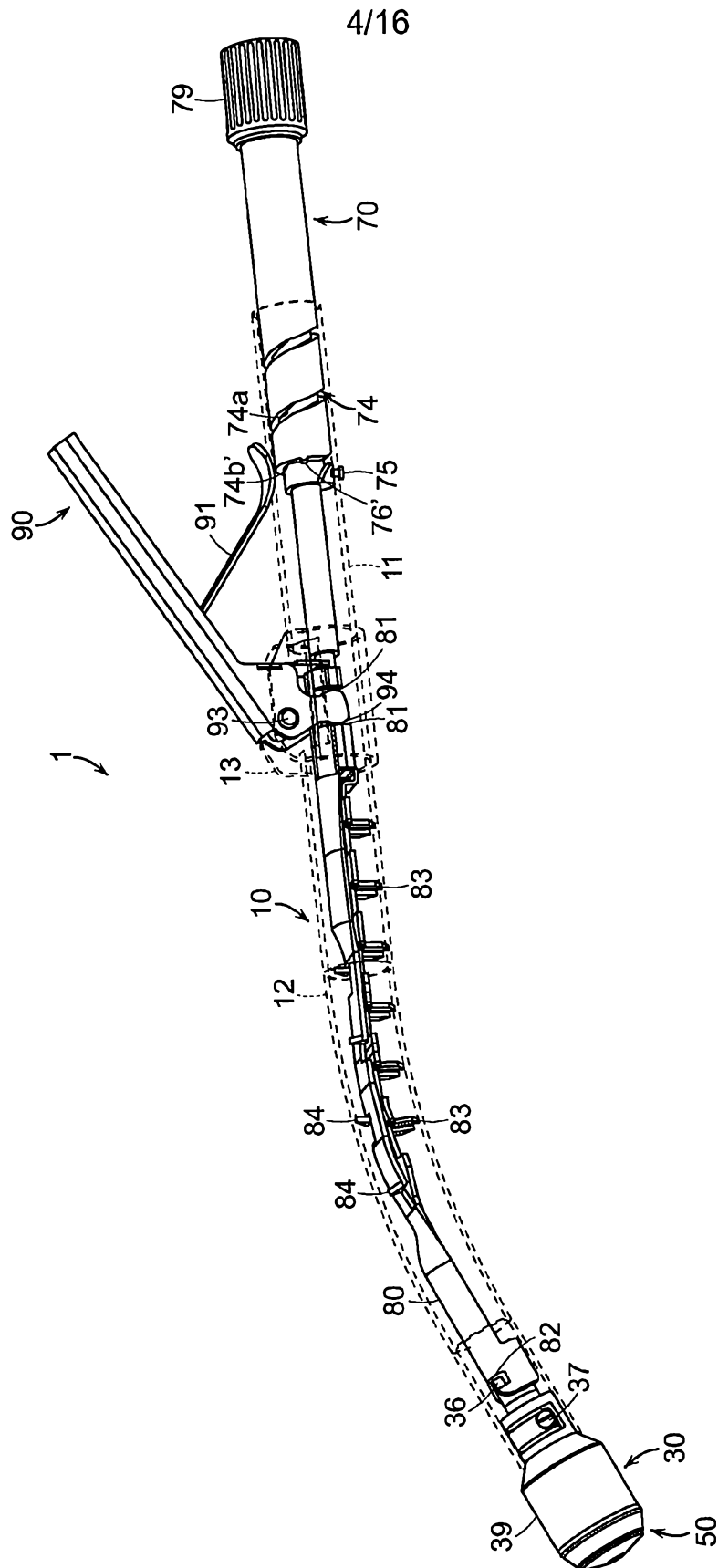

FIG. 4

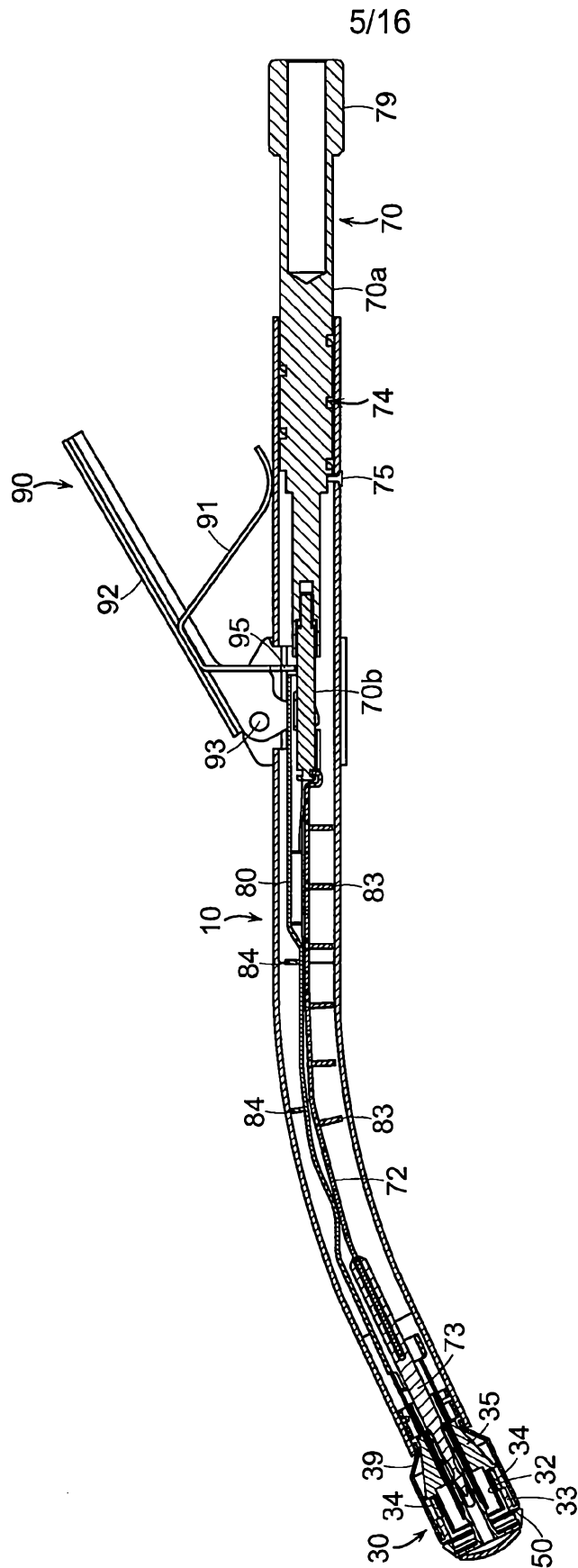

FIG. 5

6/16

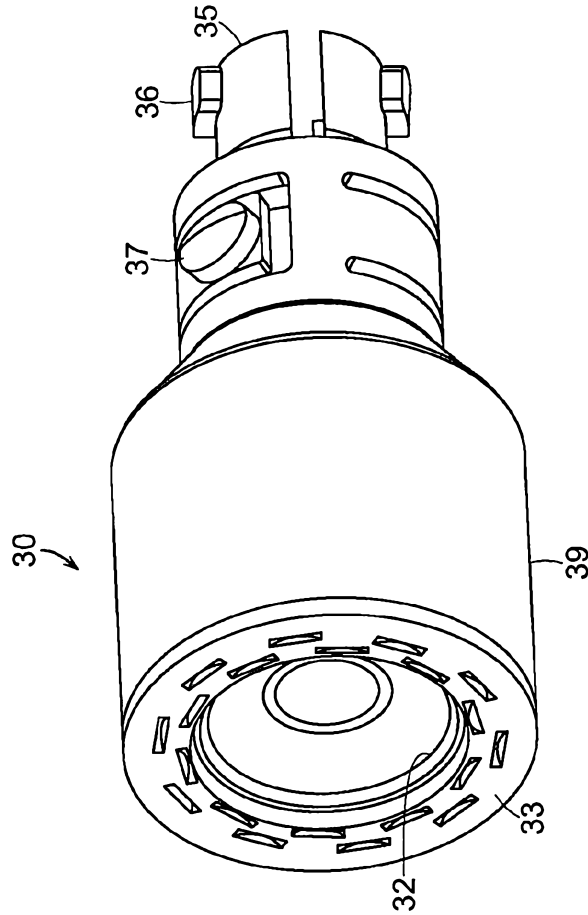

FIG. 7A

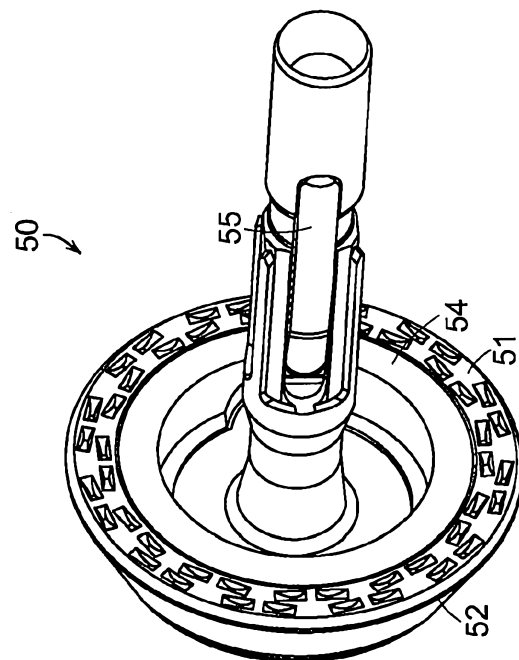

FIG. 6

7/16

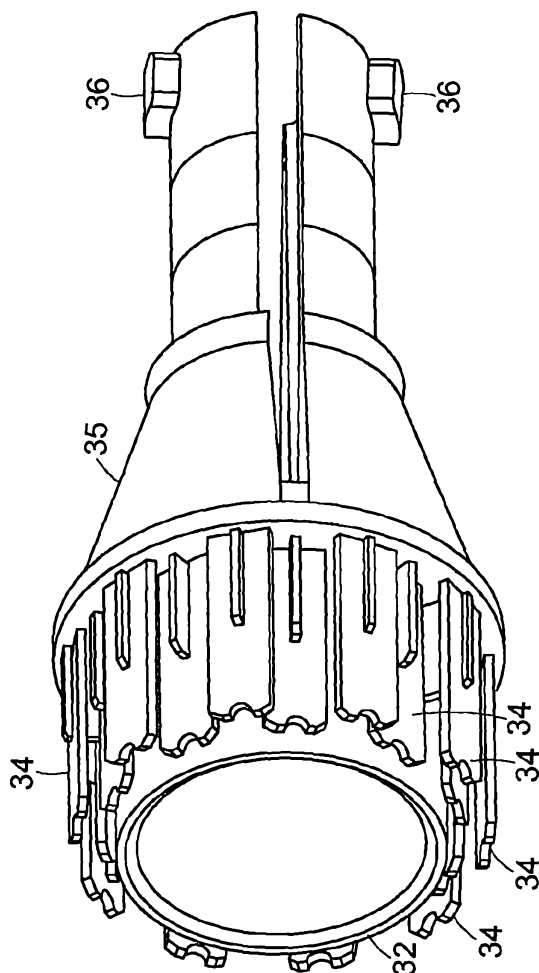

FIG. 7C

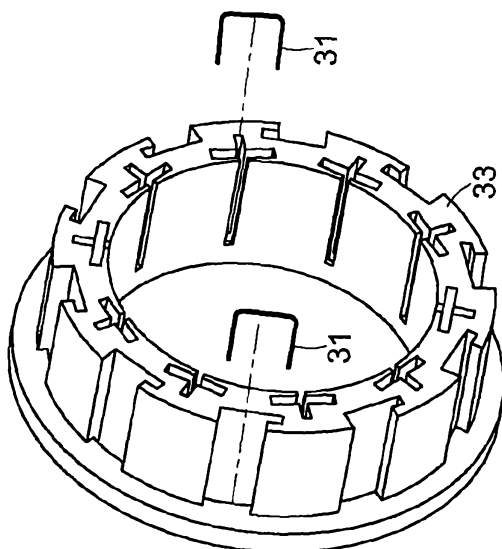

FIG. 7B

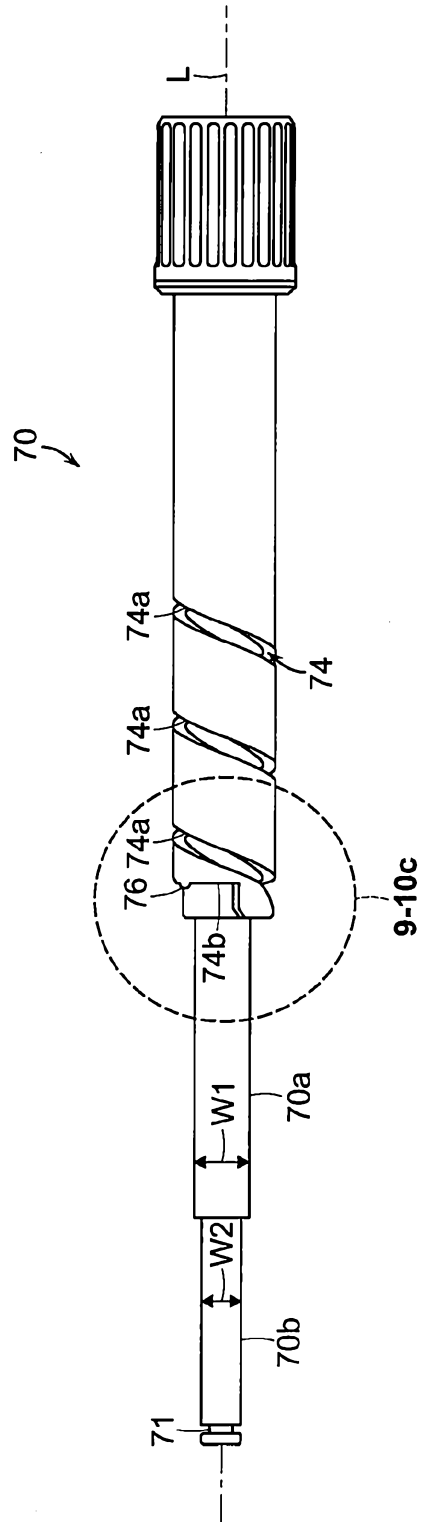

FIG. 8

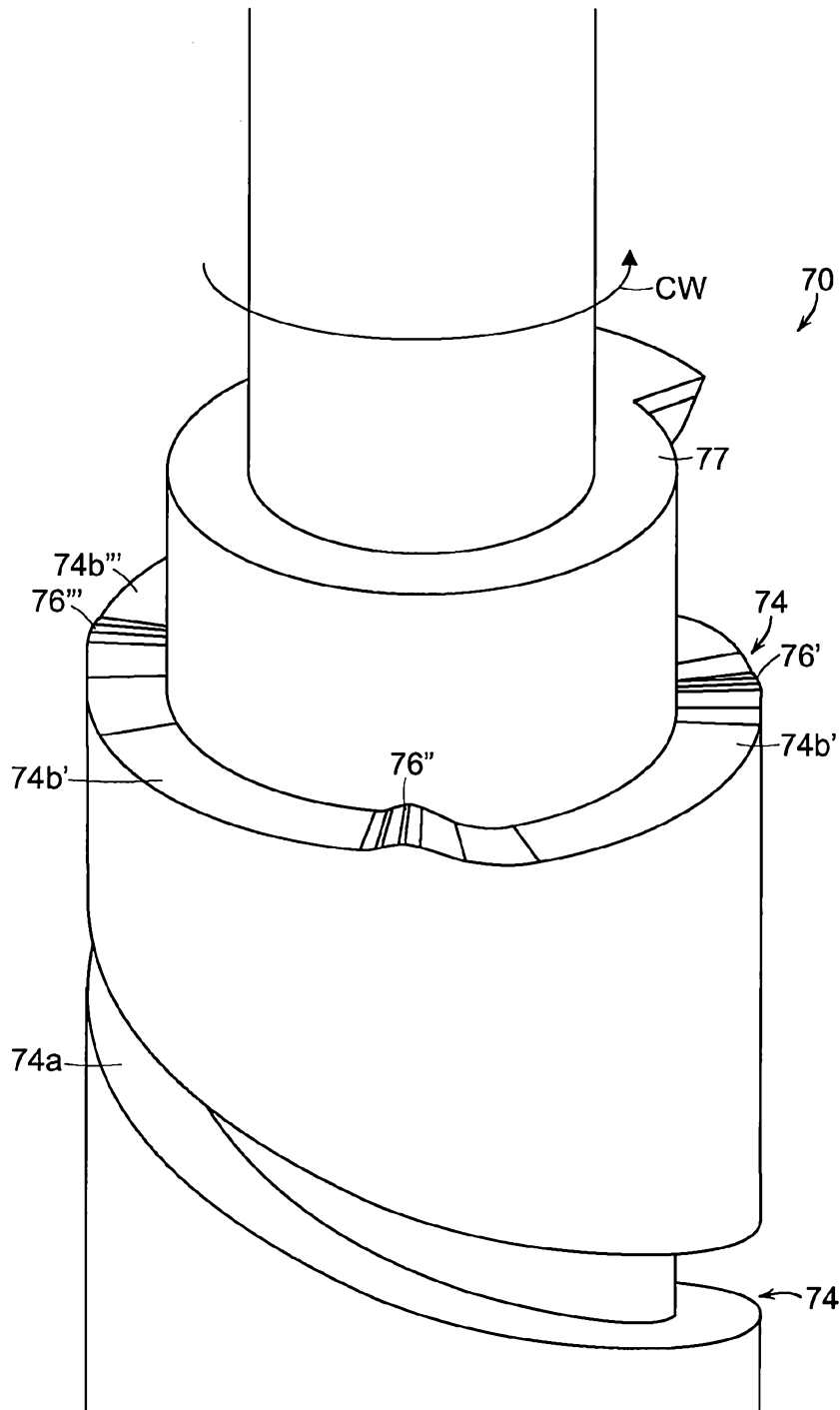

FIG. 9

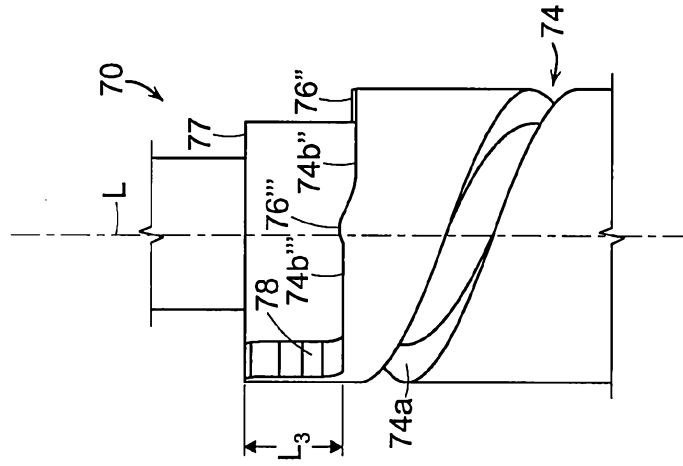

FIG. 10C

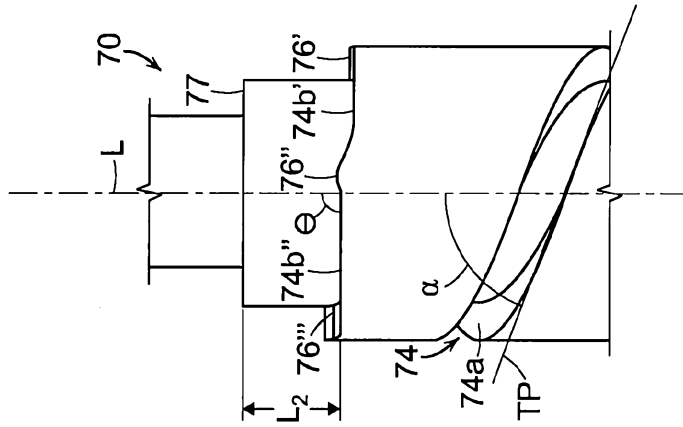

FIG. 10B

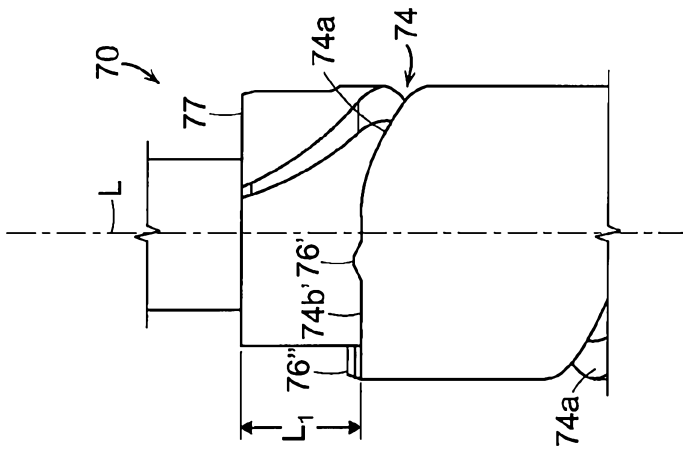

FIG. 10A

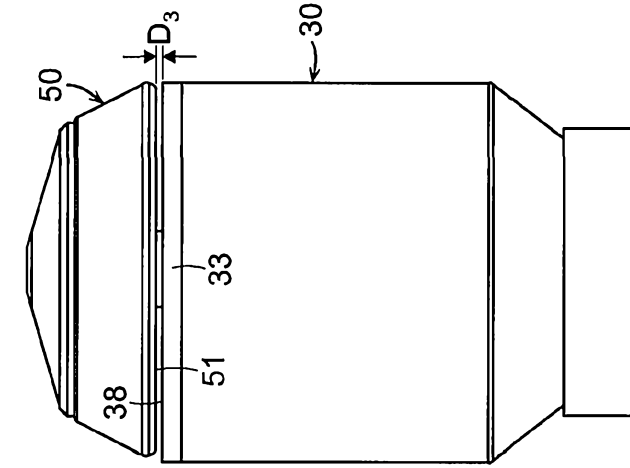

FIG. 11A

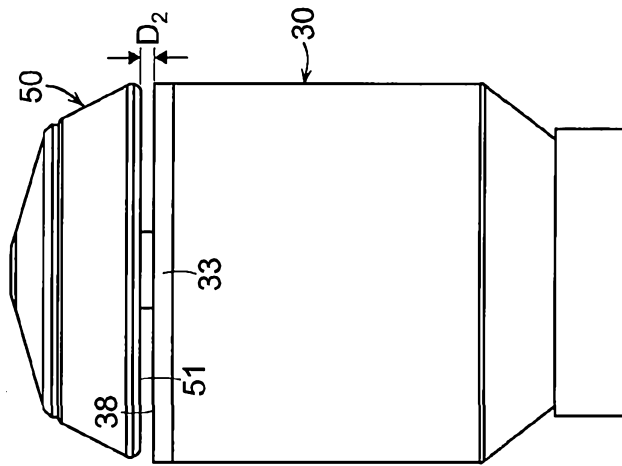

FIG. 11B

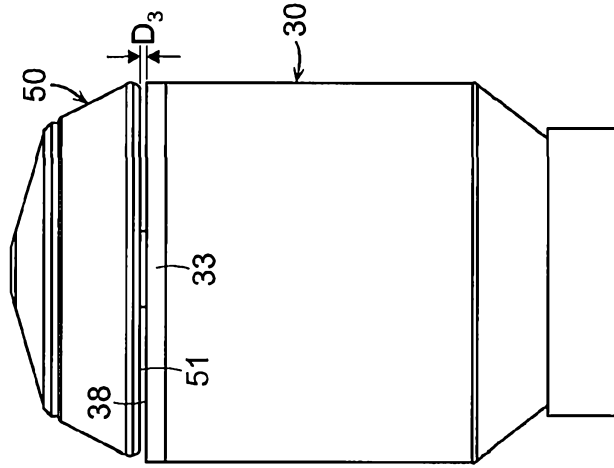

FIG. 11C

12/16

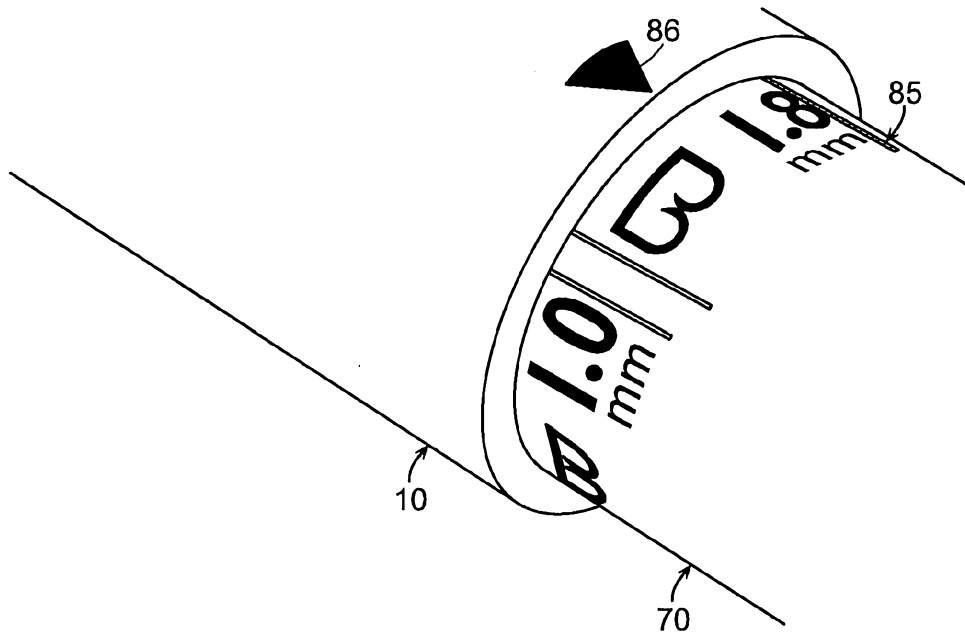

FIG. 12

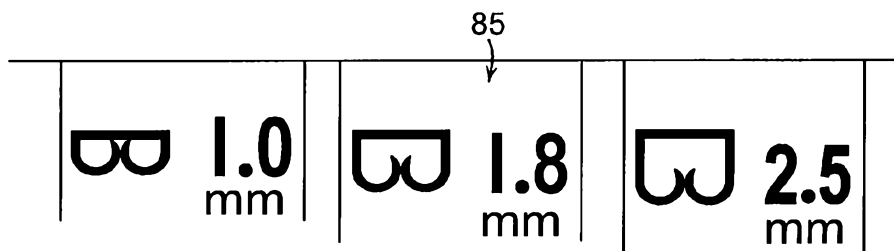

FIG. 13

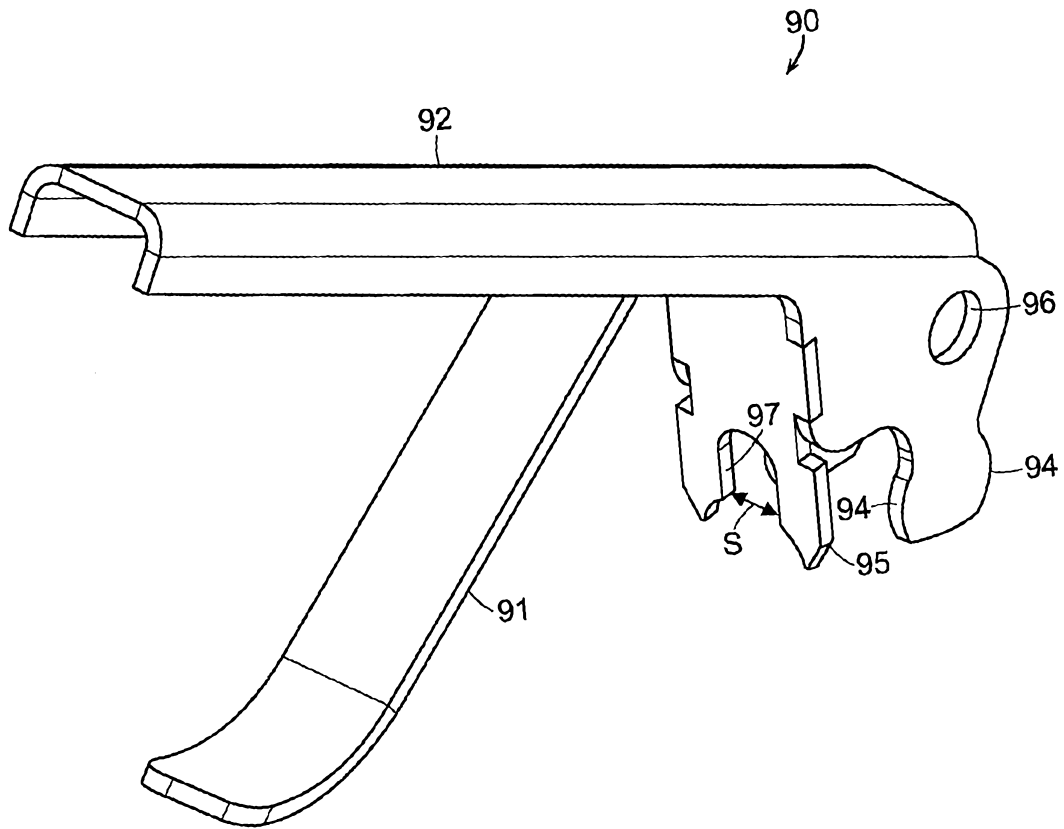

FIG. 14

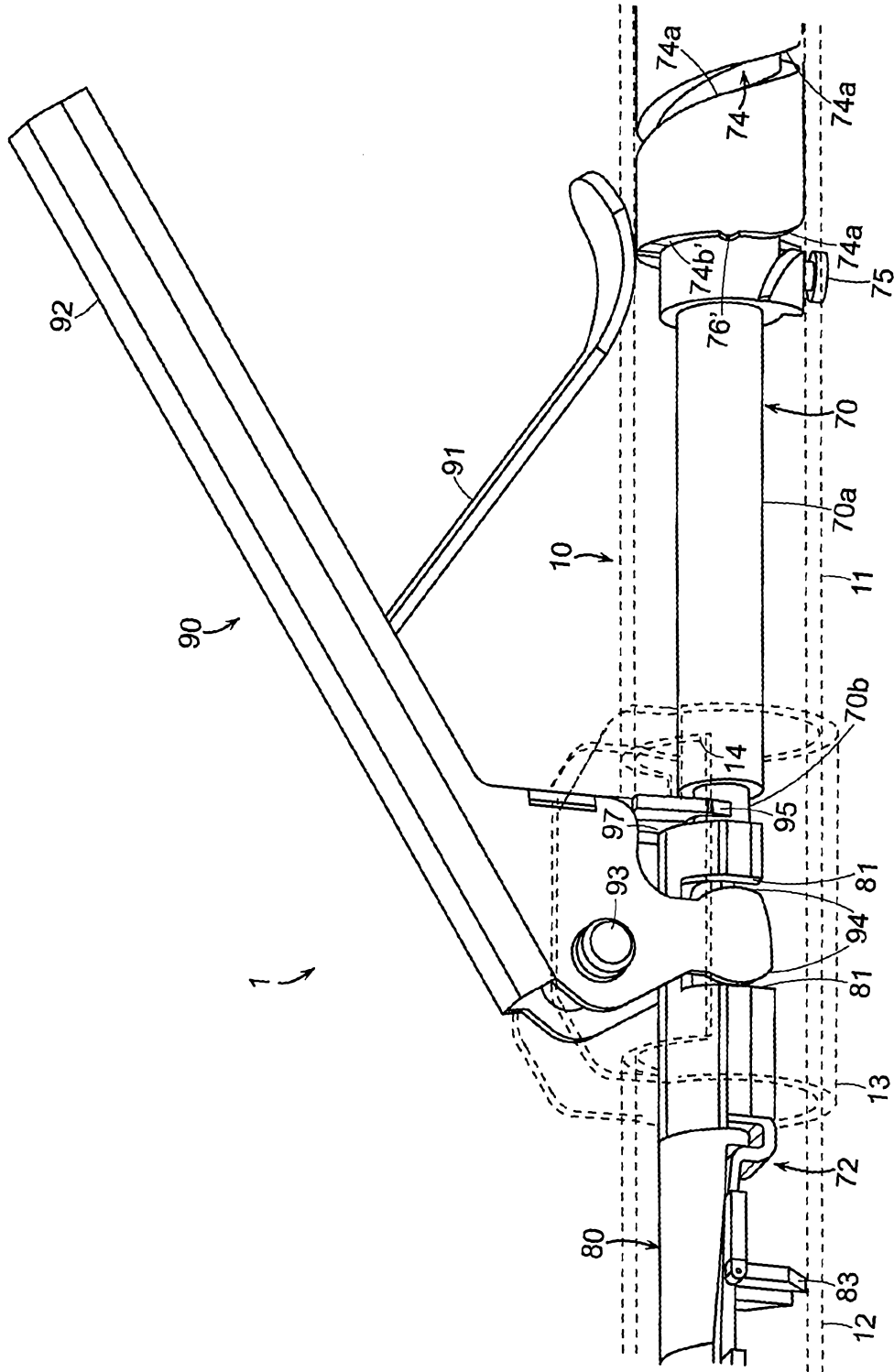

FIG. 15

15/16

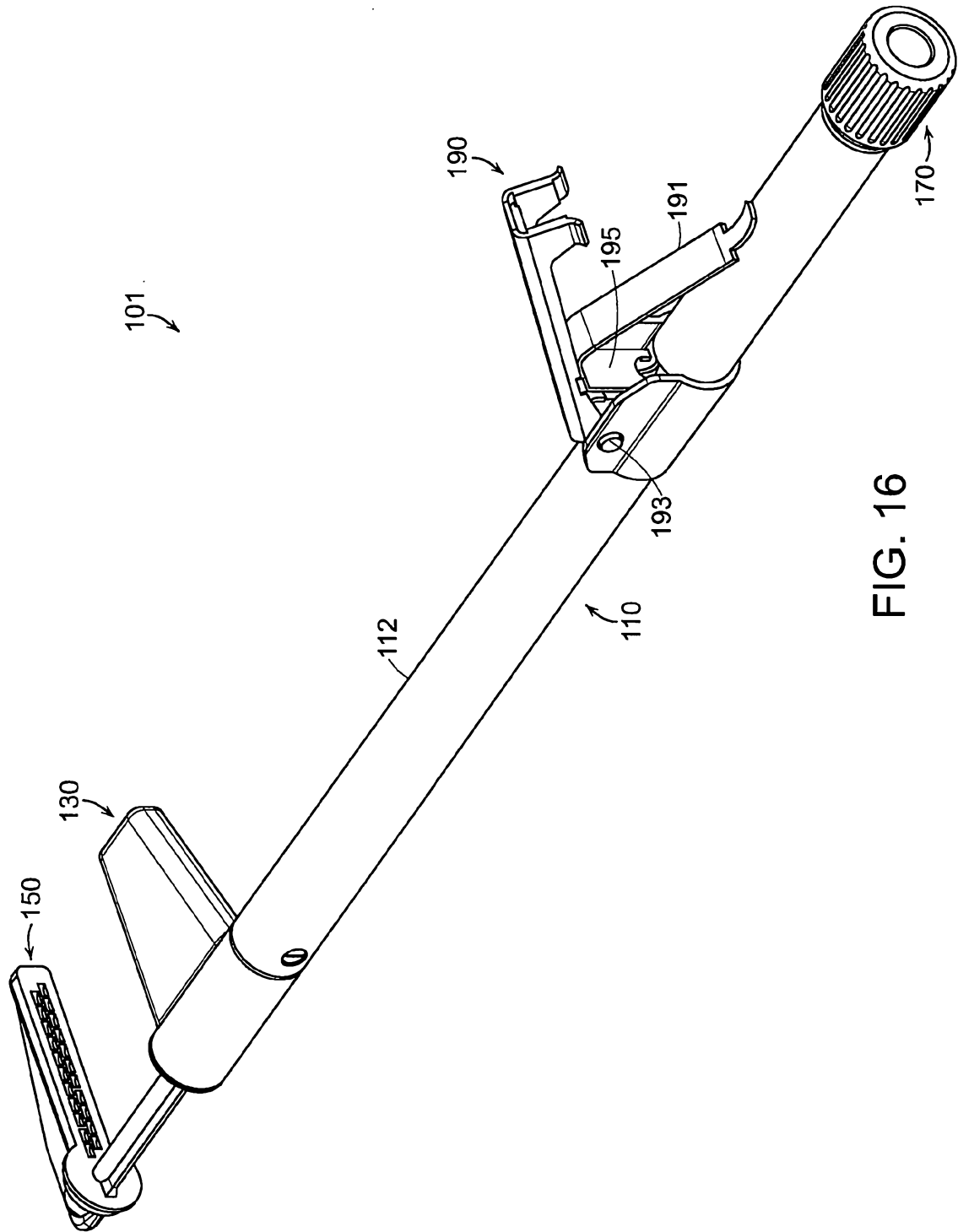

FIG. 16

16/16

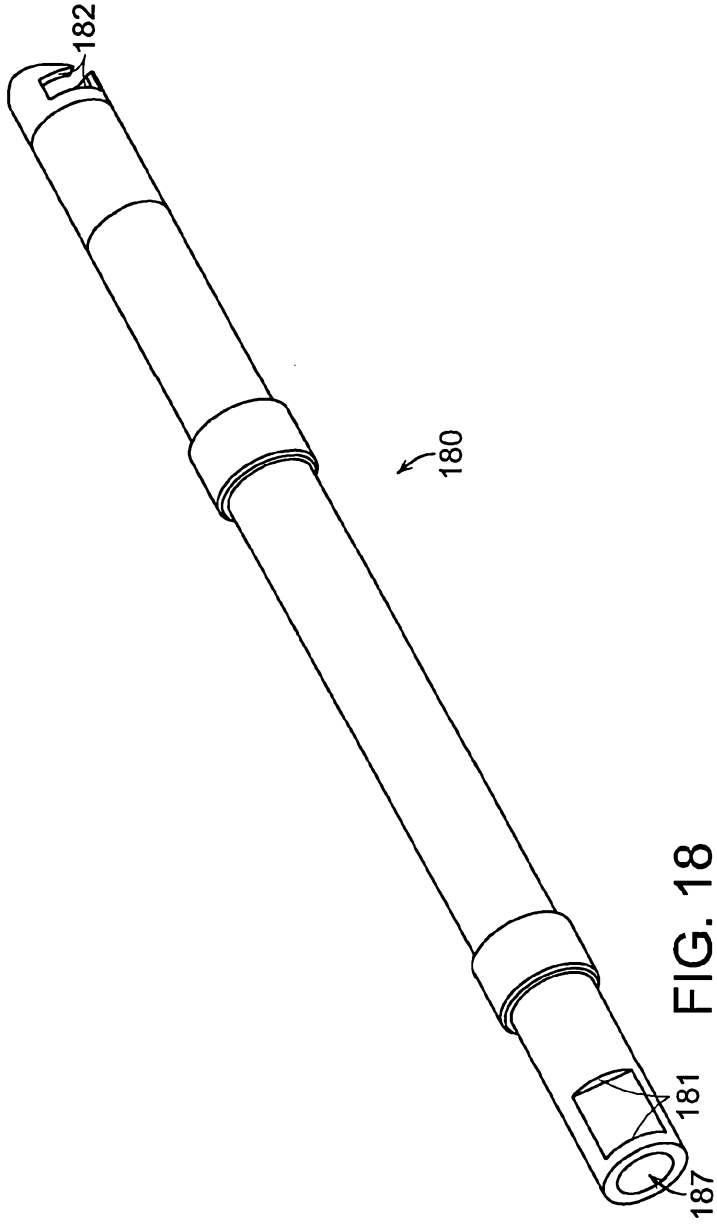

FIG. 18

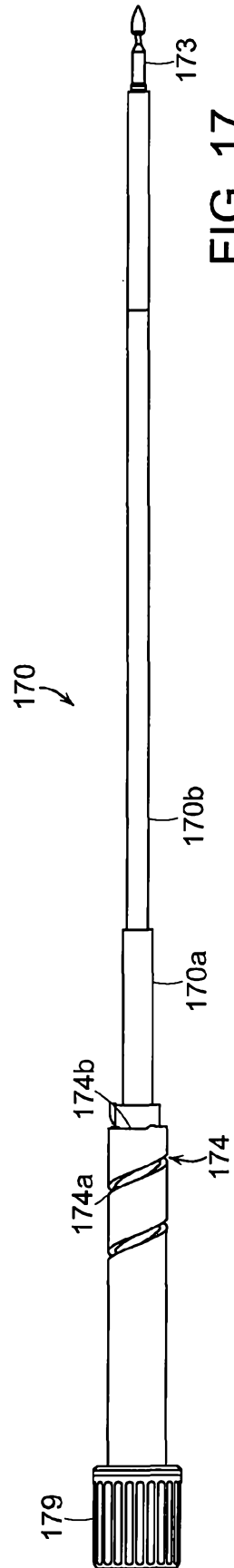

FIG. 17