

J. & T. HAWKES.

Improvement in Miter-Boxes.

No. 129,557.

Patented July 16, 1872.

Fig. 1

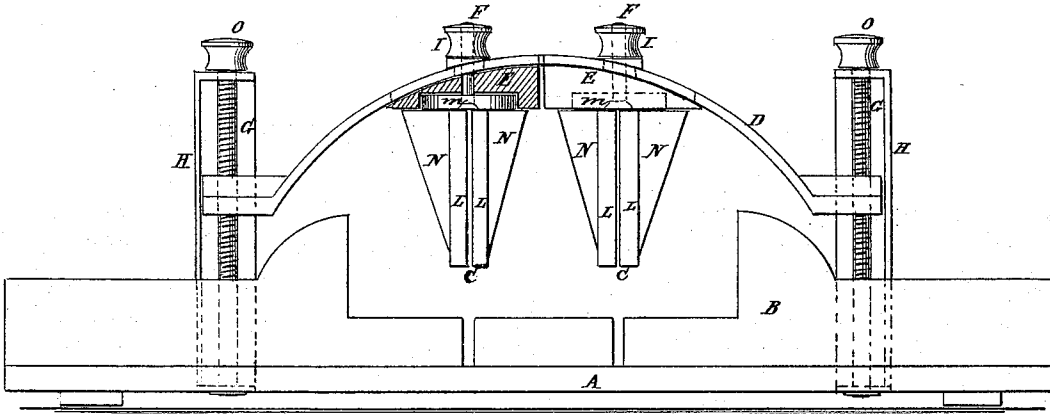

Fig. 2

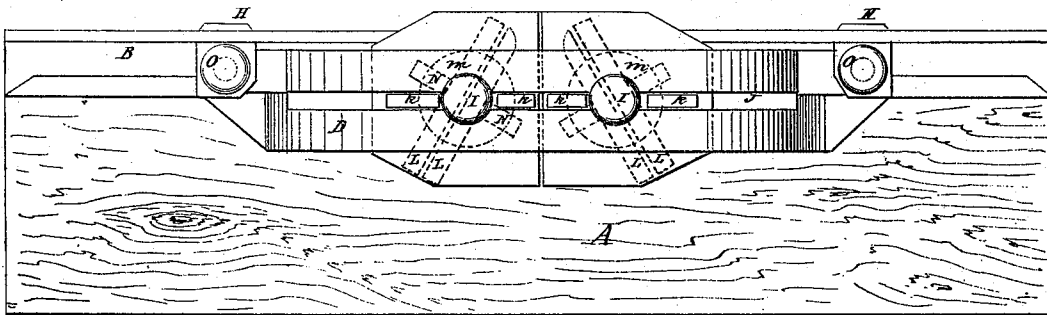

Fig. 3

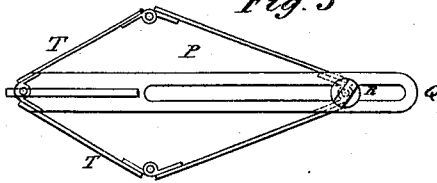
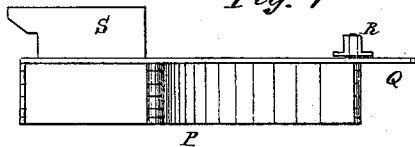

Fig. 4



Witnesses:

A. W. Amqvist
N. A. Graham

Inventor:

J. Hawkes
T. Hawkes
Munnell
Attorneys.

PER

UNITED STATES PATENT OFFICE.

JOHN HAWKES, OF NEW BRUNSWICK, AND TIMOTHY HAWKES, OF JERSEY CITY, NEW JERSEY.

IMPROVEMENT IN MITER-BOXES.

Specification forming part of Letters Patent No. 129,557, dated July 16, 1872.

Specification describing a new and useful Improvement in Miter-Boxes, invented by JOHN HAWKES, of New Brunswick, in the county of Middlesex and State of New Jersey, and TIMOTHY HAWKES, of Jersey City, in the county of Hudson and State of New Jersey.

The object of the present invention is to furnish an improved box for sawing a miter or any other desired bevel; and it consists in a bed-piece and back-rest with one or more adjustable saw-guides arranged on an adjustable slotted arch-plate by means of vertical guides and screws, and in a gauge in combination therewith, the construction and arrangement of parts being as hereinafter more fully described.

In the accompanying drawing, Figure 1 is a front view, partly in section. Fig. 2 is a top view. Fig. 3 is a top view of an adjustable gauge for getting the angle for setting the saw-guides. Fig. 4 is a side view of the same.

Similar letters of reference indicate corresponding parts.

A is the bed-piece. B is the back-rest, rising up from the bed at a right angle, like the side of the ordinary miter-box. The piece to be sawed is placed on the bed and against this guide, as in ordinary miter-boxes. C C are the adjustable saw-guides, which are connected with the metallic arch or bow D by means of sliding blocks E E and screws F F. The arch is supported at each end on the vertical screw-rods G G, which rods are confined by the angular uprights H H, which are attached to the bed-piece. These screw-rods have knobs I I on their upper ends, by which they are turned. They are so confined that they have no longitudinal motion, but simply revolve. They pass through screw-threaded holes in the ends of the arch D, so that the arch can be raised or lowered by turning them. J represents a slot in the center of the arch. The blocks E are fitted to the under circle of the arch, and have projecting lugs k, which enter the slot J and keep the blocks

in proper position when they are moved. The saw-guides are composed each of two plates, L L, fastened to a circle or disk, m, far enough from each other to admit the saw-plate, as seen in Fig. 1. N N are braces to support the plates. The disk m is let into a corresponding cavity in the under side of the blocks E and flush therewith, as indicated in dotted lines.

The screws F pass up through the disks m above the slot, and have thumb-nuts O thereon, by which the saw-guides are fastened and held in any desired position. The circular disks allow the guides to turn the saw to any desired angle, not only for sawing miters, but any desired bevel.

In many kinds of work, and especially in doing the joiner-work for ships and steamboats, it is necessary to cut double bevels; and for this description of work our box is especially adapted, as by sliding the block E down from the center any desired lateral inclination can be given the saw.

It will be seen that this box is not adapted for the common back-saw, but the saw-guides may be constructed so as to admit of their use.

For the purpose of adjusting and setting the saw-guides to cut a bevel to fit any particular angle or make any particular joint we use an adjustable gauge, P, (see Fig. 3,) constructed by hinging four plates together with a slotted central bar, Q, and set-screw R with a guide-plate, S, on the bar, by means of which it is made to fit any angle and be set thereto, and then the saw-guide may be set or adjusted to correspond therewith.

In setting the saw-guides by the gauge, either of the plates T T are placed against the back-rest B, and the plates of the saw-guide are made to correspond with the guide-plate S of the gauge.

The saw-guides are duplicates of each other, and two are used, to obviate the necessity of any change or readjustment.

Having thus described our invention, we

claim as new and desire to secure by Letters Patent—

1. In combination with the arch D and guides C, the blocks E provided with lugs *k* fitting in the slot J of said arch, as specified.

2. The arch or circle D, adjusting screw-rods G G, and uprights H H, in combination with a box for sawing miters and other bevels, substantially as shown and described.

3. The gauge P, in combination with the adjustable saw-guides C, substantially as and for the purposes described.

JOHN HAWKES.
TIMOTHY HAWKES.

Witnesses:

T. B. MOSHER,
W. A. GRAHAM.