

July 31, 1962

P. H. SHERRON

3,046,614

CORNER POST CONNECTION FOR TELEPHONE BOOTH

Filed Jan. 24, 1961

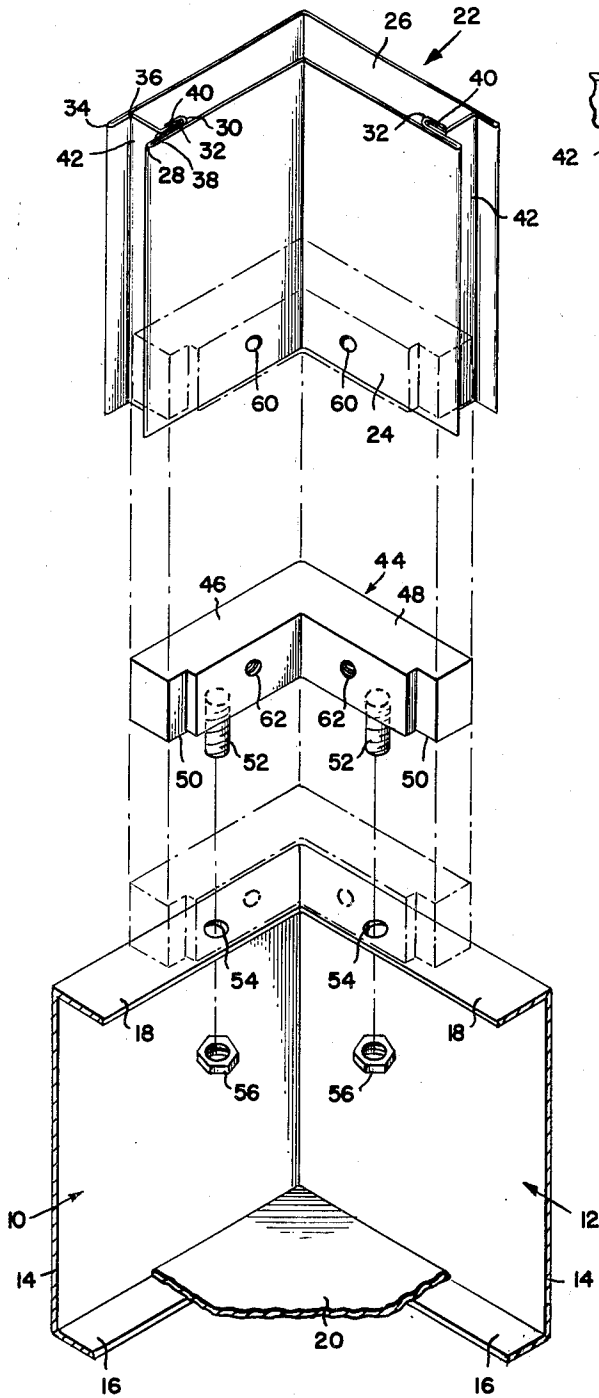

FIG. 1.

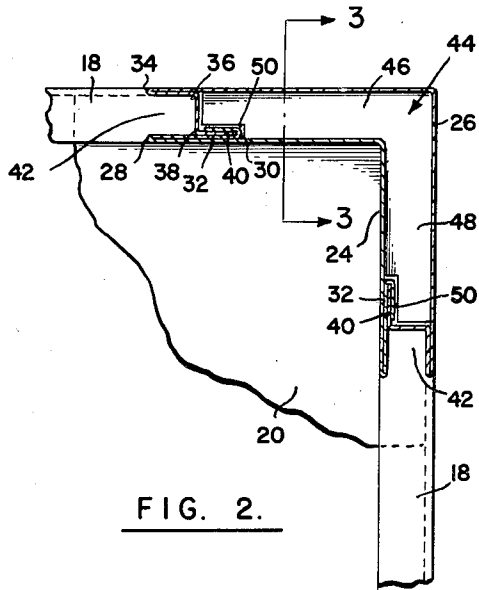

FIG. 2.

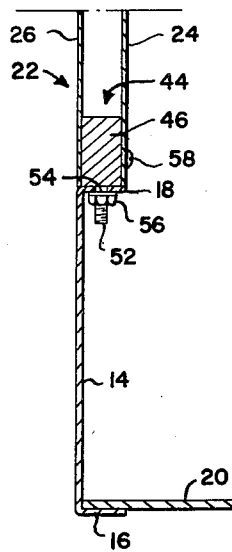

FIG. 3.

INVENTOR.

PERCIVAL H. SHERRON

BY

*Cusser, Smith & Harding*

ATTORNEYS

1

3,046,614

**CORNER POST CONNECTION FOR TELEPHONE BOOTH**

Percival H. Sherron, Jamaica, N.Y. (% Sherron Metallic Corporation, 1201 Flushing Ave., Brooklyn 37, N.Y.)

Filed Jan. 24, 1961, Ser. No. 84,578  
2 Claims. (Cl. 20-3.5)

This invention relates generally to telephone booths, and particularly to improvements in means for effecting end connections for the corner posts of a telephone booth.

An object of the invention is to provide means for anchoring the end portions of tubular corner posts to overlying members abutting the same.

Other objects of the invention will become apparent when the following description is read with reference to the accompanying drawing, in which:

FIGURE 1 is an exploded perspective view looking down into a corner of a telephone booth constructed in accordance with the invention;

FIGURE 2 is a horizontal section through the corner of the telephone booth; and

FIGURE 3 is a vertical section on the plane indicated by line 3-3 of FIGURE 2.

Referring to the drawing, a horizontal base frame is provided with a pair of base members 10 and 12 disposed normal to one another. Each base member is provided with an upright web 14, a laterally extending bottom flange 16 and a laterally extending top flange 18. Overlying the flanges 16 is a floor plate 20.

Over the corner of the base frame is an upright corner post, generally designated 22, which includes an inner section 24 and an outer section 26. The inner section 24 has opposite side longitudinally extending areas disposed at right angles to one another. Each opposite side marginal area of section 24 is provided with longitudinally extending bends, as at 28 and 30, to form a hook 32. The outer section 26 has opposite side longitudinally extending areas disposed at right angles to one another. Each opposite side marginal area of section 26 is provided with longitudinally extending bends, as at 34, 36 and 38, to provide a lip 40 which interlocks with the associated hook 32 of section 24. Thus there is provided a deep recess 42 extending along each edge of the post.

Snugly fitted into the lower end portion of the exemplary post 22 is an L-shaped insert or fitting, generally designated 44, having legs 46 and 48 disposed normal to one another, which legs are rectangular in transverse section. The remote ends of the legs 46 and 48 are notched, as at 50, to clear the hooks 32, and depending from the undersurface of the legs 46 and 48 are, respectively, a pair of studs 52, which studs extend freely through holes 54 in the flanges 18. Nuts 56 threaded on the studs 52 draw the fitting 44 down tight upon the flanges 18, and screws 58 projected through holes 60 in the inner section 24 of the post and threaded into the tapped holes 62 respectively in the legs 46 and 48 of the fitting 44 secure the post to the fitting 54.

Obviously, the post 22 may be a rolled or extruded member of metal or a suitable plastic material. The fitting may be cast or otherwise formed of metal or a suitable plastic material.

2

It will be understood, of course, that the present invention is susceptible of various modifications which may be made without departing from the general principles of the invention. Accordingly, it is intended to claim the same broadly as well as specifically, as indicated by the appended claims.

What is claimed is:

1. In a telephone booth, the combination comprising an upright sheet metal hollow corner post L-shaped in transverse section including one-piece inner and outer sections each having a longitudinally extending right angle bend providing opposite side areas normal to each other, the remote longitudinally extending marginal portions of the inner section being reversely bent sharply to form a pair of hooks the bights of which face away from said right angle bends, the remote longitudinally extending marginal portions of the outer section being bent to provide a pair of lips presenting toward said right angle bends and interlocking respectively with said hooks, an L-shaped insert fitted snugly into and affixed to the lower end portion of said post including a pair of legs each rectangular in transverse section and notched to clear the associated one of said hooks, and a pair of threaded elements affixed to and depending respectively from the undersurfaces of said legs, and a horizontally disposed sheet metal base including a pair of members forming a right angle corner portion underlying said insert, each of said members being channel shaped in transverse section, the web being upright and the upper and lower flanges extending laterally from said web, said insert being seated respectively upon, and said threaded elements being projected respectively through, said top flanges for securing said post to said base through said insert.

2. In a telephone booth, the combination comprising an upright sheet metal hollow corner post L-shaped in transverse section including one-piece inner and outer sections each having a longitudinally extending right angle bend providing opposite side areas normal to each other, the remote longitudinally extending marginal portions of the inner section being reversely bent sharply to form a pair of hooks the bights of which face away from said right angle bends, the remote longitudinally extending marginal portions of the outer section being bent to provide a pair of lips presenting toward said right angle bends and interlocking respectively with said hooks, an L-shaped insert fitted snugly into and affixed to the lower end portion of said post including a pair of legs each rectangular in transverse section and notched to clear the associated one of said hooks, and a pair of threaded elements affixed to and depending respectively from the undersurfaces of said legs, and a horizontally disposed base having openings through which said threaded elements project for securing said post to said base through said insert.

References Cited in the file of this patent

UNITED STATES PATENTS

1,423,468	Stadelman	July 18, 1922
1,652,612	Daniels	Dec. 13, 1927
2,614,664	Sherron	Oct. 21, 1952
2,764,314	Mautner	Sept. 25, 1956