



US006915768B2

(12) **United States Patent**
Ohsawa

(10) **Patent No.:** **US 6,915,768 B2**
(45) **Date of Patent:** **Jul. 12, 2005**

(54) **VARIABLE OPERATING VALVE APPARATUS FOR AN INTERNAL COMBUSTION ENGINE**

JP 10-18823 1/1998
JP 2002-147241 5/2002

(75) Inventor: **Hiroshi Ohsawa, Shizuoka (JP)**

OTHER PUBLICATIONS

(73) Assignee: **Suzuki Motor Corporation, Shizuoka-Ken (JP)**

English Language Abstract of JP 5-18221.

English Language Abstract of JP 10-18823.

English Language Abstract of JP 2002-147241.

(*) Notice: Subject to any disclaimer, the term of this patent is extended or adjusted under 35 U.S.C. 154(b) by 0 days.

* cited by examiner

(21) Appl. No.: **10/728,822**

Primary Examiner—Thomas Denion

Assistant Examiner—Ching Chang

(22) Filed: **Dec. 8, 2003**

(74) *Attorney, Agent, or Firm*—Greenblum & Bernstein, P.L.C.

(65) **Prior Publication Data**

US 2004/0118370 A1 Jun. 24, 2004

(57) **ABSTRACT**

(30) **Foreign Application Priority Data**

Dec. 24, 2002 (JP) 2002-372285

(51) **Int. Cl.**⁷ **F01L 1/34**

(52) **U.S. Cl.** **123/90.16; 123/188.1; 123/198 F**

(58) **Field of Search** 123/90.16, 198 F, 123/90.15, 90.17, 90.18, 445, 188.1

(56) **References Cited**

U.S. PATENT DOCUMENTS

5,636,613 A * 6/1997 Aoyama et al. 123/432
6,708,659 B2 * 3/2004 Katayama 123/90.31
6,742,483 B2 * 6/2004 Asakura 123/90.16
2003/0062211 A1 4/2003 Tsuruda

FOREIGN PATENT DOCUMENTS

JP 5-18221 1/1993

12 Claims, 9 Drawing Sheets

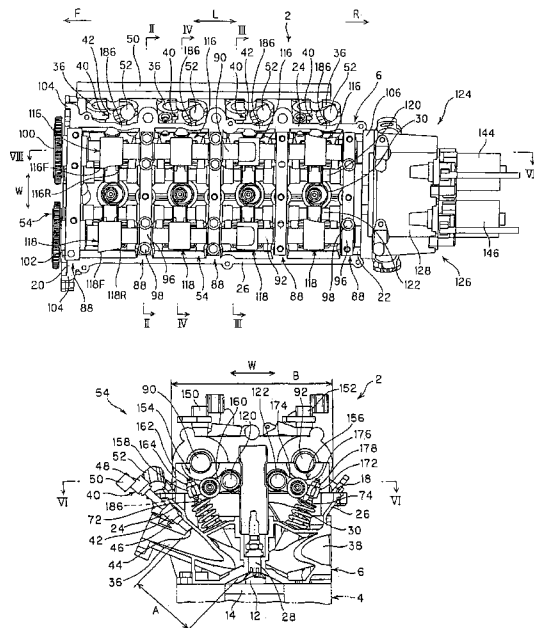

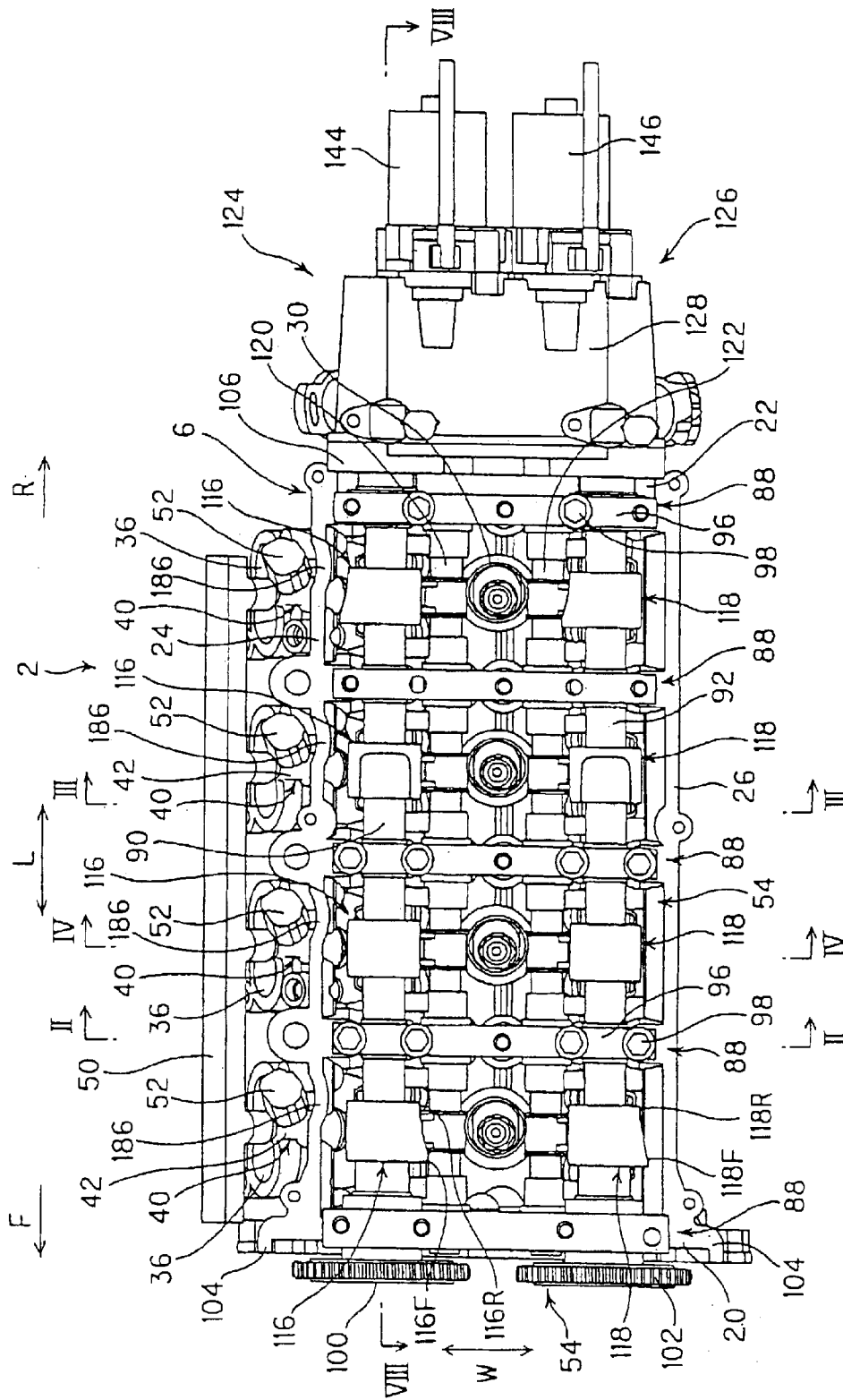

FIGURE 1

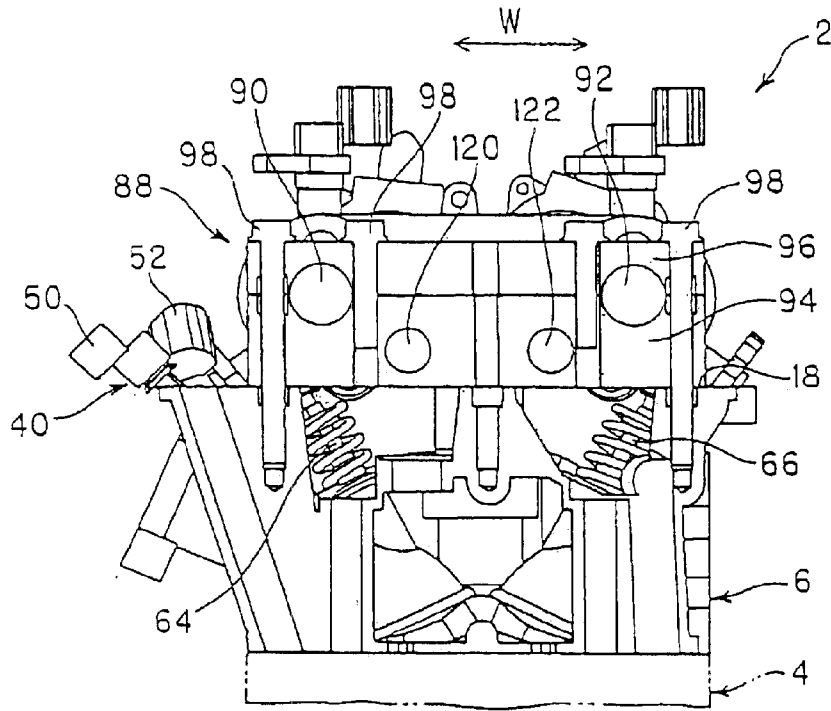

FIGURE 2

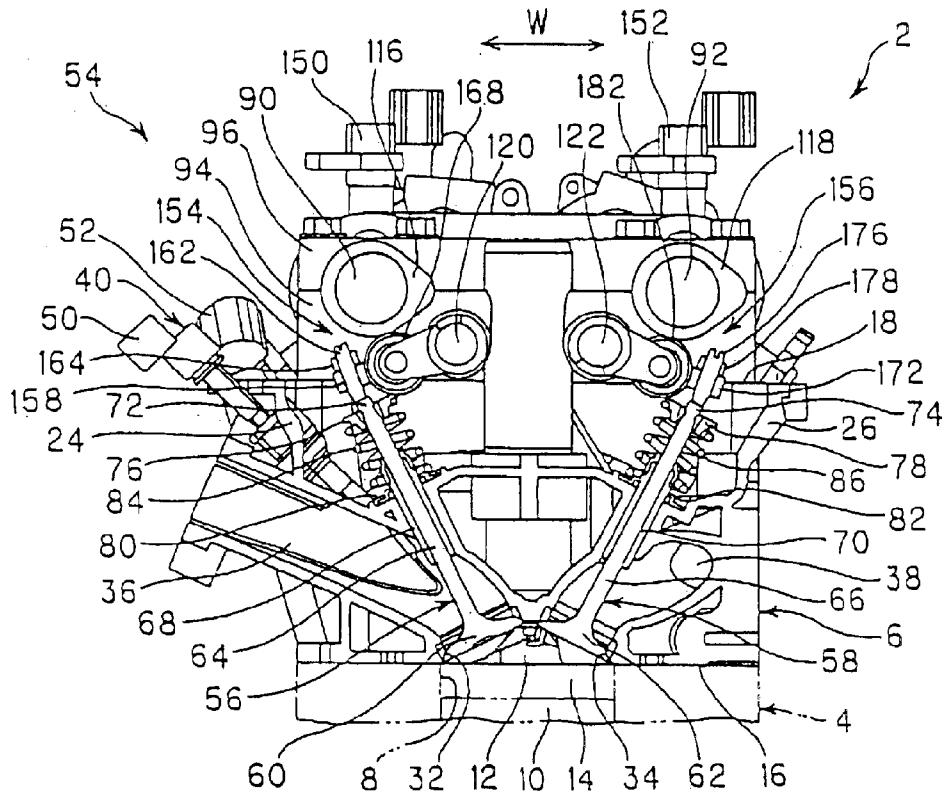

FIGURE 3

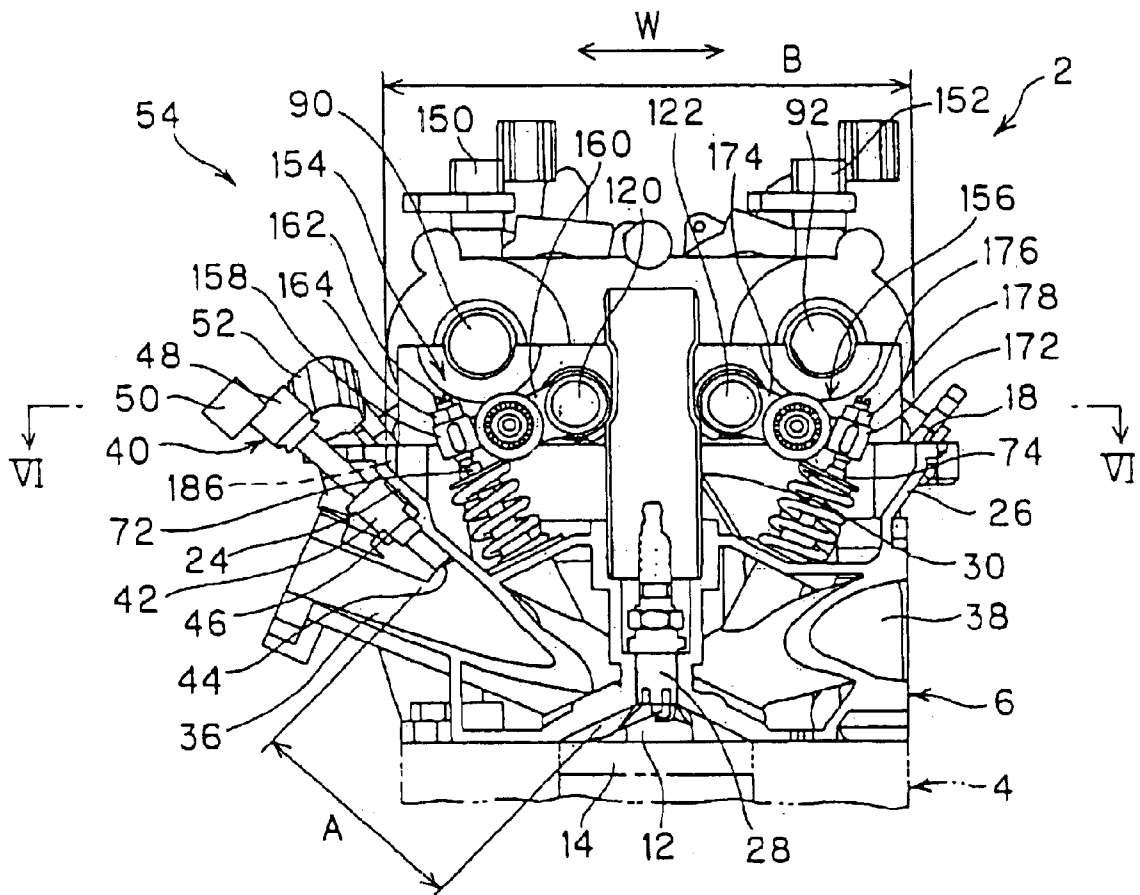

FIGURE 4

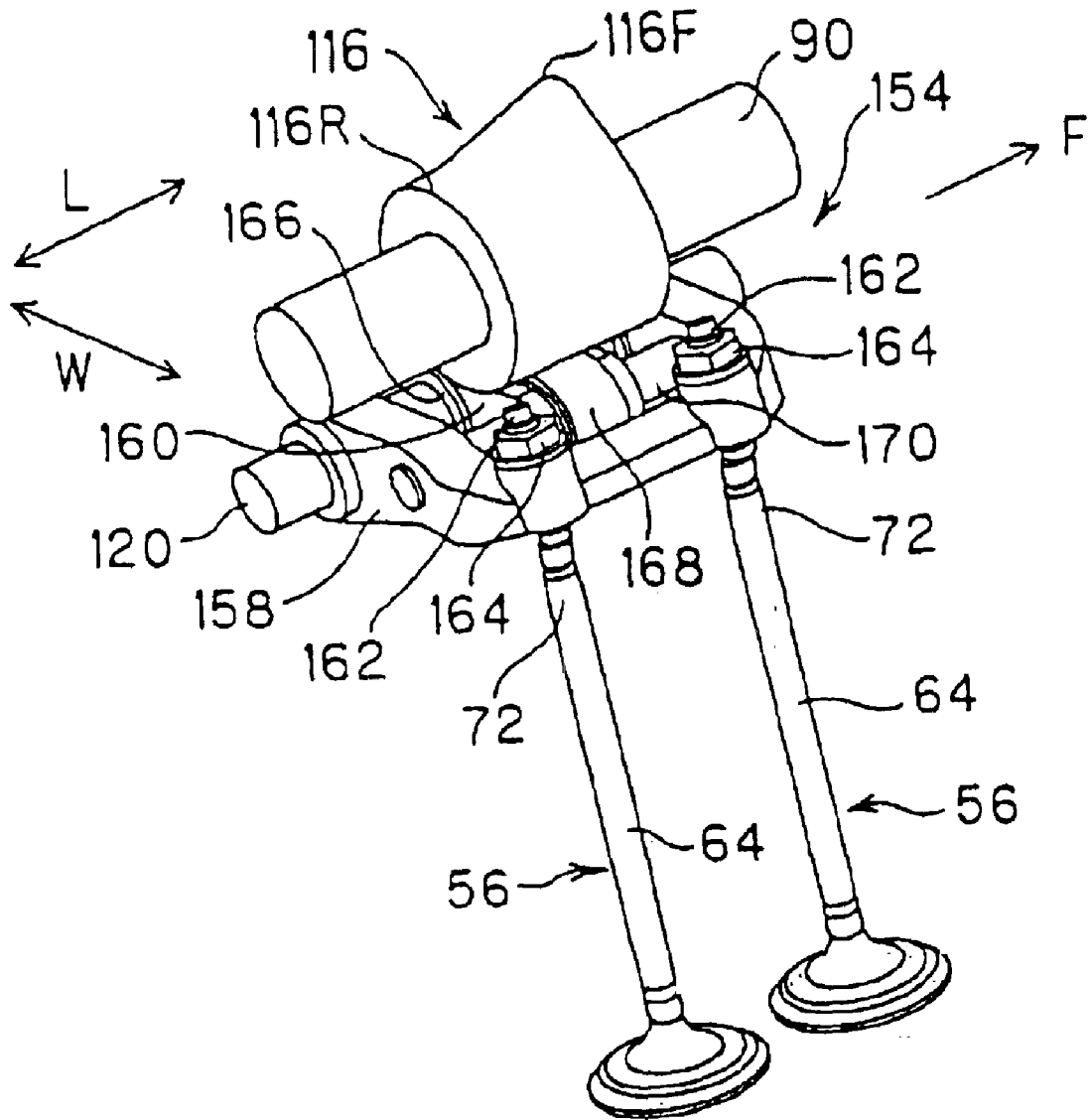

FIGURE 5

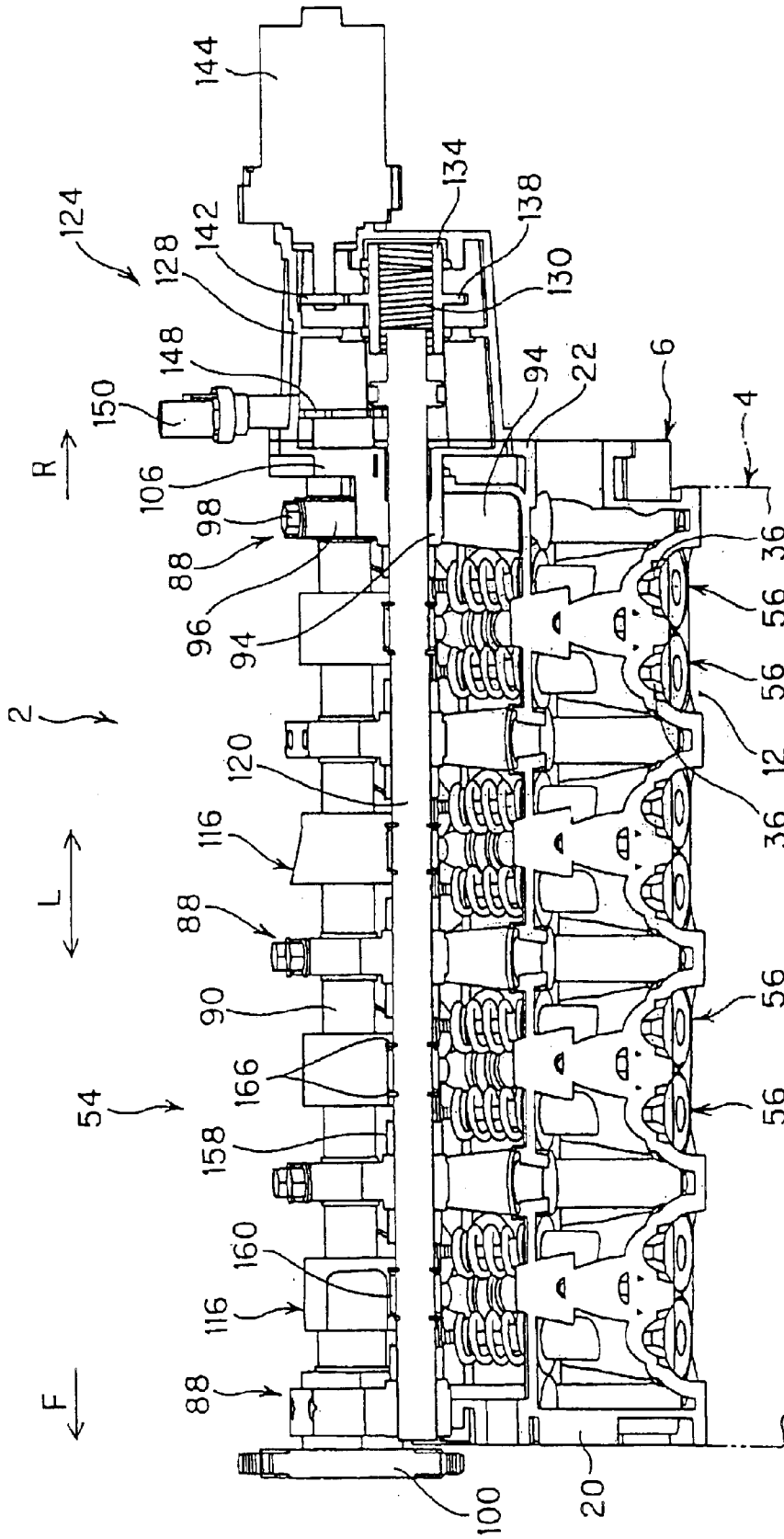

FIGURE 7

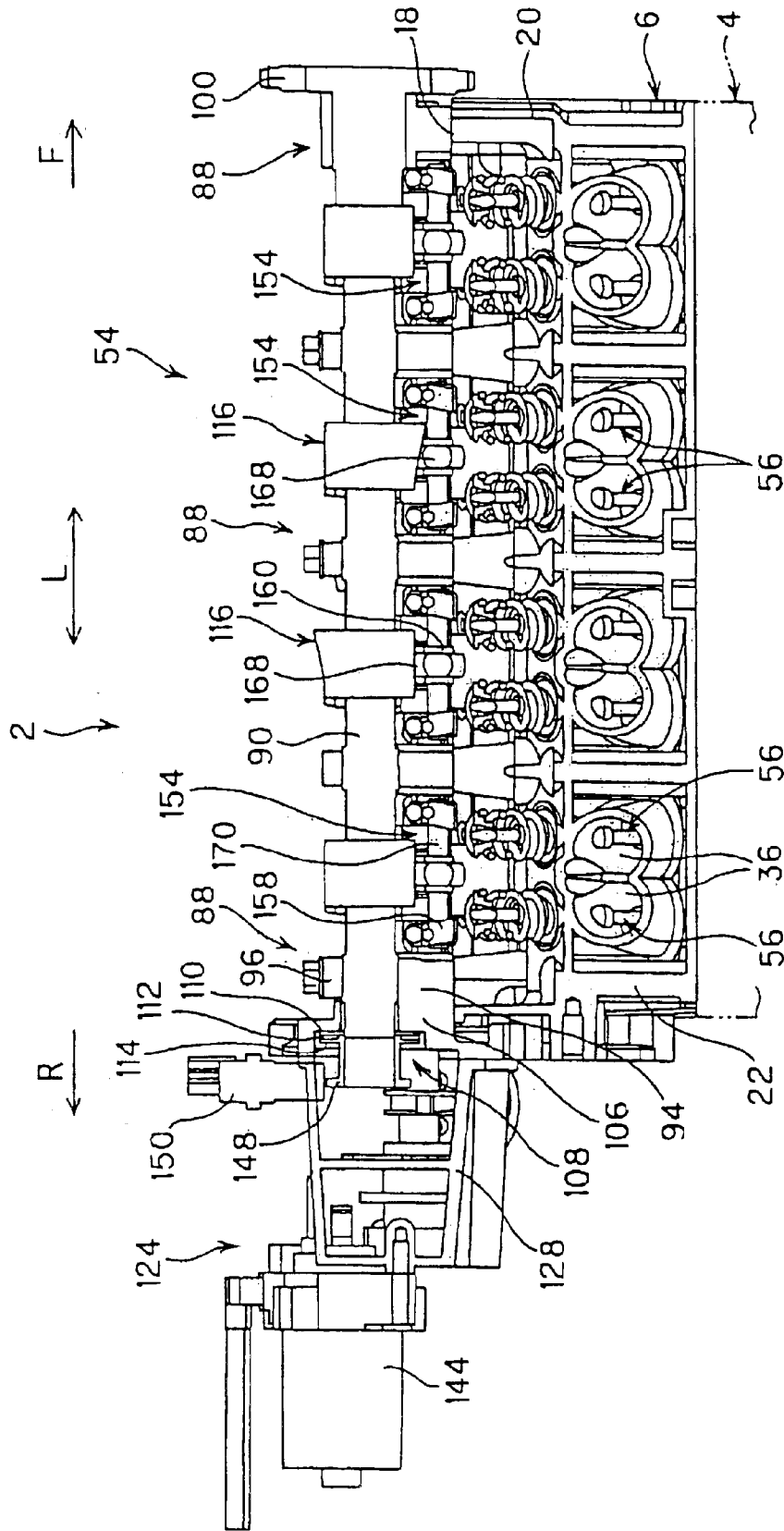

FIGURE 8

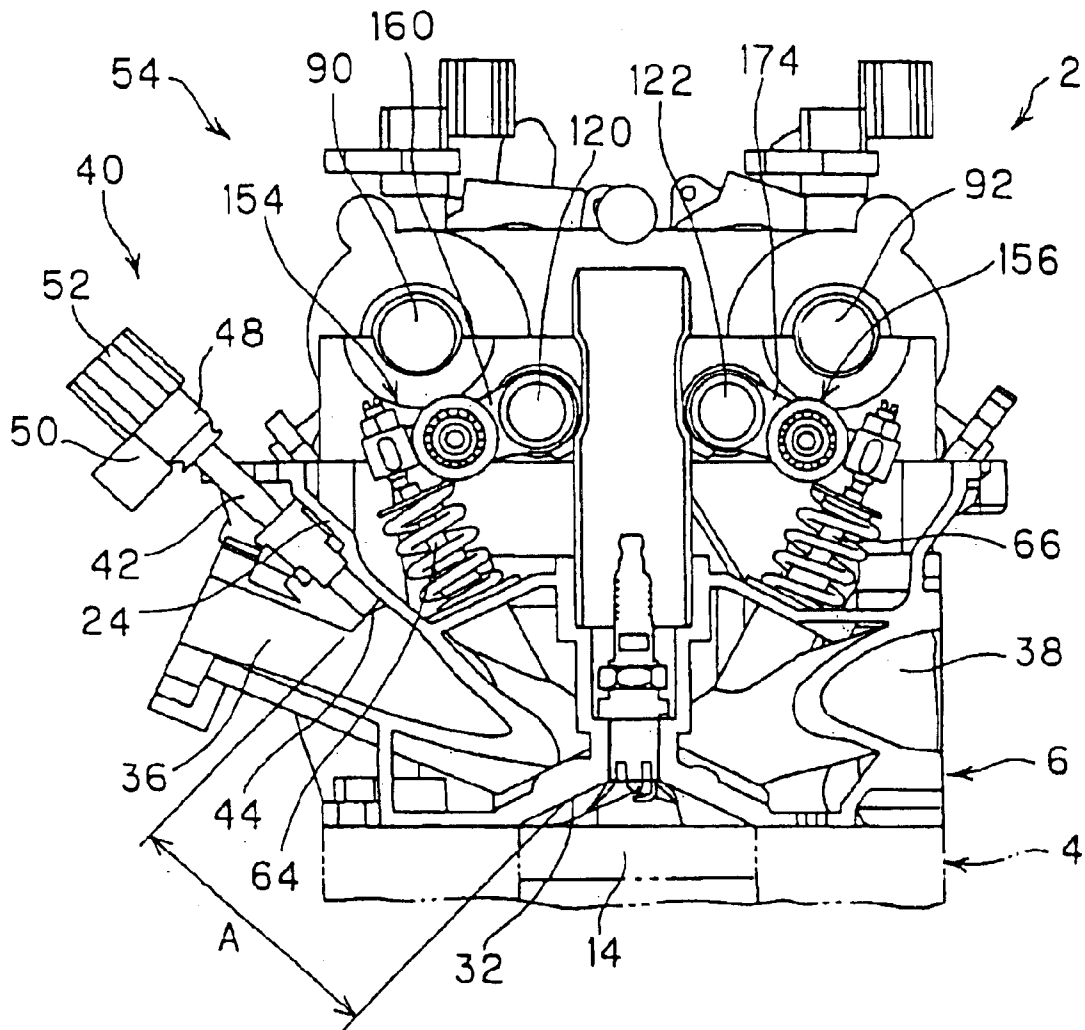

FIGURE 9

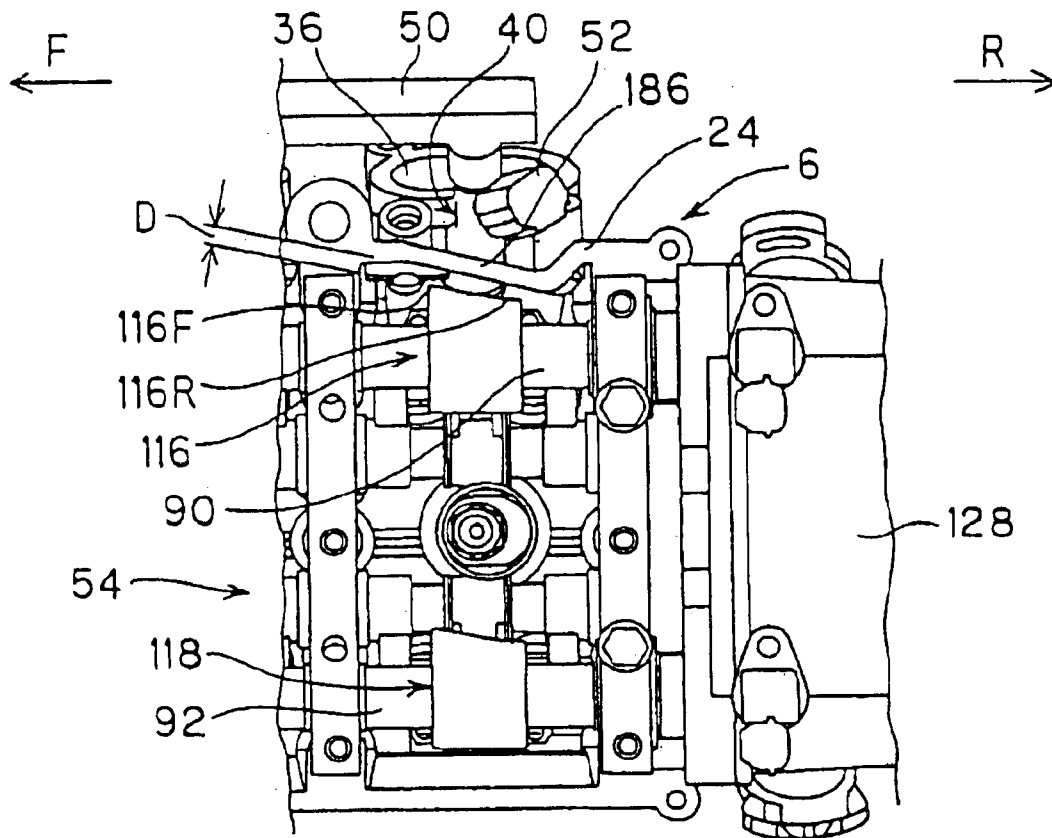

FIGURE 10

VARIABLE OPERATING VALVE APPARATUS FOR AN INTERNAL COMBUSTION ENGINE

BACKGROUND OF THE INVENTION

1. Field of the Invention

The present invention relates to a variable valve mechanism for an internal combustion engine. More specifically, the present invention relates to a variable valve mechanism that allows a fuel injector to be installed at a location that provides for improved combustion performance, without increasing the width of the engine's cylinder head.

2. Description of Background Information

A variable valve mechanism has been applied to engines used in automotive vehicles as manner of variably controlling the extent and duration of valve lift for a valve that opens and closes an intake port leading to a combustion chamber. Furthermore, a fuel injector is provided to lower undesirable exhaust gas emissions.

The prior art includes a variable valve mechanism, of the type applied to an engine, that includes a camshaft that synchronously rotates with a crankshaft, a solid cam with an axially changing profile formed on the camshaft, an actuator that changes the position of the cam profile in the axial direction in response to engine operating conditions, a swinging rocker arm equipped with components that contact multiple valves, a sub-rocker arm supporting a roller follower that rotatably contacts the solid cam, and a sub-rocker support part that supports the swinging movement of the sub-rocker on the rocker arm (see for example, Japanese Published Patent Application H5-18221, pages 3-4 and FIG. 1).

Japanese Published Patent Application H10-18823 (see pages 3-4 and FIG. 1) discloses another type of variable valve mechanism that includes a solid cam camshaft that incorporates a variable low to high-speed profile that changes continuously along the axial direction, an actuator that changes the axial position of the camshaft in relation to engine operating conditions, and an arm that moves in synchronization with two or more adjacent valves and whose movement is dependent on the profile of the solid cam. The aforesaid arm incorporates a follower mechanism that follows positional changes in the linear contact angle of the rotating solid cam through a follower in contact therewith, and two or more contact members that press against the ends of two or more valves.

Japanese Published Application 2002-147241 (see pages 3-4 and FIG. 4) discloses another type of engine in which there is a positional relationship between a fuel injector and a cylinder head.

Currently known variable valve mechanisms of the type applied to internal combustion engines, such as those noted in Japanese Published Patent Application H5-18221 and Japanese Published Patent Application H10-18823, describe a mechanism that includes a camshaft onto which a three-dimensional cam (hereafter referred to as a 3D cam) is formed having a profile that varies along the axial direction, and valves that open and close according to the rotation of the 3D cam, wherein the amount of valve lift varies depending on the positional relationship between the 3D cam and valve stem. These variable valve mechanisms described by Japanese Published Patent Application H5-18221 and Japanese Published Patent Application H10-18823 employ a mechanism in which the valve is driven by the rotational movement of the 3D cam being transferred to the valve through a rocker arm.

Moreover, some internal combustion engines place the fuel injector as close to the combustion chamber as possible in an effort to lower exhaust gas emissions and improve combustion performance. For example, the fuel injector shown in Japanese Published Application 2002-147241 is located in the middle at the top of the cylinder in order to inject fuel directly into the combustion chamber.

These known variable valve mechanisms exhibit an undesirable characteristic in that the use of 3D cams to open and close valves through rocker arms has the effect of increasing the width (the transverse direction) at a right angle to the axial centerline of the camshaft) of the cylinder head. Furthermore, increasing the width of the cylinder head makes it more difficult to locate the injector (which sprays fuel into the intake port leading to the combustion chamber) close to the combustion chamber.

In order to solve the shortcomings of the prior art, the present invention proposes a variable valve mechanism that axially supports the camshaft, on which a 3D cam is formed, at least on the intake port side of the cylinder head, locates the fuel injector in the part of the intake sidewall bordering the intake port of the cylinder head, and provides for a concave part, formed in the intake sidewall, that extends inward toward the intake camshaft at a location above the fuel injector. This structure prevents the sidewall from obstructing the installation of the fuel injector to the cylinder head, and allows the fuel injector to be located in closer proximity to the combustion chamber.

SUMMARY OF THE INVENTION

Accordingly, one aspect of the present invention is to provide a variable valve mechanism. The variable valve mechanism includes a camshaft, which is axially supported by an engine cylinder head, onto which a three-dimensional cam is formed to a profile that changes along the axial direction. The camshaft is axially supported at least on an intake port side of the cylinder head. The variable valve mechanism also includes a rocker shaft actuator that changes an axial position of a rocker shaft in response to engine operating conditions, a valve lift volume setting mechanism configured to alter an amount of lift of a valve dependent on the extent of axial movement of the rocker shaft, a fuel injector installed on a part of an intake sidewall bordering the intake port of the cylinder head, in which the fuel injector is configured to spray fuel into an intake port, and a concave part formed in the intake sidewall and extending inward toward the camshaft at a location above the fuel injector.

The concave part is formed at least on a part of said intake sidewall directly opposite a fuel injector harness connector. The fuel injector is installed at the intake sidewall so as to incline the harness connector in a direction away from a sprocket attached to an axial end of the camshaft. The camshaft is axially supported by the cylinder head so that a maximum lift profile of the three-dimensional cam is oriented toward an end of the camshaft to which the sprocket is attached, in which the profile is the part of the cam that applies a maximum valve lift.

According to another aspect of the present invention, a variable valve mechanism for an internal combustion engine is provided. The variable valve mechanism includes a camshaft, axially supported by an engine cylinder head, in which the camshaft includes a three-dimensional cam having a profile that varies along a length of the cam. The variable valve mechanism also includes a rocker shaft

having an axial position that changes in response to engine operating conditions, a valve lift volume setting mechanism configured to alter the lift of a valve in response to an amount of axial movement of the rocker shaft, and a fuel injector, configured to spray fuel into an intake port, attached at an intake sidewall, in which the intake sidewall includes a concavity adjacent the fuel injector.

The concavity may include an angular depression extending inward in the direction of the camshaft. Further, the concavity may be formed opposite a connector associated with the fuel injector. Still further, the connector may be angled away from a sprocket on the camshaft. The camshaft may include a maximum lift profile portion that is oriented toward a sprocket end side of the camshaft.

According to another aspect of the present invention, a variable valve mechanism for an internal combustion engine is provided. The variable valve mechanism includes a camshaft, axially supported by an engine cylinder head, in which the camshaft includes a three-dimensional cam having a profile that varies along a length of the cam. The variable valve mechanism also includes a rocker shaft having an axial position that changes in response to engine operating conditions, a valve lift volume setting mechanism configured to alter the lift of a valve in response to an amount of axial movement of the rocker shaft, and a fuel injector, configured to spray fuel into an intake port, attached at an intake sidewall. A connector and a fuel rail, each being associated with the fuel injector are attached to a rearward end of a casing of said fuel injector. As a result, the connector and the fuel rail are not obstructed by the intake side wall.

BRIEF DESCRIPTION OF THE DRAWINGS

The above, and other objects, features and advantages of the present invention will be made apparent from the following description of the preferred embodiments, given as non-limiting examples, with reference to the accompanying drawings, in which:

FIG. 1 is a plan view of an engine to which the first embodiment of the variable valve mechanism is equipped, according to an aspect of the present invention;

FIG. 2 is a cross section of the engine shown in FIG. 1 as taken from line II—II, according to an aspect of the present invention;

FIG. 3 is a cross section of the engine shown in FIG. 1 as taken from line III—III, according to an aspect of the present invention;

FIG. 4 is a cross section of the engine shown in FIG. 1 as taken from line IV—IV, according to an aspect of the present invention;

FIG. 5 is an oblique view of an intake valve lift volume setting mechanism, according to an aspect of the present invention;

FIG. 6 is a cross section taken from line VI—VI of the FIG. 4, according to an aspect of the present invention;

FIG. 7 is a cross section taken from line VII—VII of the FIG. 6, according to an aspect of the present invention;

FIG. 8 is a cross section taken from line VIII—VIII of the engine shown in FIG. 1, according to an aspect of the present invention;

FIG. 9 is a cross section of an engine to which a second embodiment of the variable valve mechanism is installed, according to an aspect of the present invention; and

FIG. 10 is a partial plan view of the engine to which a third embodiment of the invention is installed, according to an aspect of the present invention.

DETAILED DESCRIPTION OF THE PREFERRED EMBODIMENTS

The particulars shown herein are by way of example and for purposes of illustrative discussion of the embodiments of the present invention only and are presented in the cause of providing what is believed to be the most useful and readily understood description of the principles and conceptual aspects of the present invention. In this regard, no attempt is made to show structural details of the present invention in more detail than is necessary for the fundamental understanding of the present invention, and the description is taken from the drawings making apparent to those skilled in the art how the forms of the present invention may be embodied in practice.

The variable valve mechanism invention described by the present invention specifies a concave part that allows for the non-obstructed installation of a fuel injector into the intake sidewall of a cylinder head without interference therewith, thereby allowing the fuel injector to be located in closer proximity to the combustion chamber.

As a result, the variable valve mechanism allows the fuel injector to be placed at a location beneficial to combustion performance, without increasing the width of the cylinder head in the transverse direction, even though the camshaft, onto which three-dimensional cams are formed, is axially supported on the intake port side of the cylinder head.

FIGS. 1 through 8 will now be referred to with respect to a first embodiment of the present invention. FIG. 3 illustrates an engine 2 which is installed to a vehicle (not shown in the drawing), a cylinder block 4, a cylinder head 6, a cylinder 8, a piston 10, a head chamber 12, and a combustion chamber 14. The engine 2 includes the cylinder head 6 and the cylinder block 4, in which the cylinder head 6 is attached to the cylinder block 4 at a lower head surface 16. A head cover (not shown in the drawing) attaches to an upper surface 18 of the cylinder head 6. The combustion chamber 14 is defined by the cylinder 8 and the piston 10 in the cylinder block 4, and the head chamber 12 in the cylinder head 6.

The engine 2 is a four-cylinder engine in which each of the four cylinders 8 is located in linear alignment with an adjacent cylinder, each cylinder 8 being equipped with two intake and two exhaust valves (four-valve engine).

As shown in the FIG. 1, the cylinder head 6 of the engine 2 is formed to an approximate rectangular shape with the four cylinders 8 being arranged in linear alignment in the lengthwise (L) direction as opposed to the shorter transverse (W) direction. A front wall 20 and a rear wall 22 are located at the respective front (F) and rear (R) sides of engine 2 in the lengthwise (L) direction, and an intake sidewall 24 and an exhaust side wall 26 are located on their respective sides of the engine 2 in the transverse (W) direction. As shown in FIG. 4, a spark plug 28 is installed in the center of the cylinder head 6 along the transverse (W) direction facing the head chamber 12. A plug guide tube 30, which is installed over the spark plug 28, rises to a point above the upper head surface 18.

As shown in FIG. 3, intake and exhaust ports 36 and 38, respectively, are formed within the intake sidewall 24 and the exhaust sidewall 26 of the cylinder head 6, and respectively lead to intake and exhaust valve orifices 32 and 34, respectively, which are formed in the head chamber 12 of the combustion chamber 14. A fuel injector 40 is installed at the intake sidewall 24 and sprays fuel into the combustion

5

chamber 14 through the intake port 36. As illustrated in FIG. 4, a nozzle 44 of a fuel injector casing 42 is inclined toward the intake port 36 through its placement within an injector installation orifice 46 formed in the intake sidewall 24. A rearward end 48 of the fuel injector casing 42 connects to a fuel rail 50. A harness connector 52 is attached to the fuel injector casing 42 near the rearward end 48 in proximity to the intake sidewall 24.

The engine 2 is equipped with a variable valve mechanism 54 which includes an intake valve 56 and an exhaust valve 58 that operate to respectively open and close the intake and the exhaust ports 36 and 38, respectively, of the cylinder head 6. Moreover, in this embodiment, the engine 2 is a four-valve engine in which each cylinder 8 is equipped with two intake valves 56 and two exhaust valves 58.

As illustrated in FIG. 3, an intake valve head 60 and an exhaust valve head 62, which are formed on the ends of the intake valve 56 and the exhaust valve 58, respectively, move with a motion that opens and closes the intake and the exhaust valve orifices 32 and 34, respectively. An intake valve stem 64 and an exhaust valve stem 66 are movably supported along their axial direction by an intake valve stem guide 68 and an exhaust valve stem guide 70 of the cylinder head 6.

The intake and exhaust valves 56 and 58 are equipped with intake and exhaust spring retainers 76 and 78, respectively, that are installed to intake valve stem tip 72 of the intake valve stem 64, and exhaust valve stem tip 74 of the exhaust valve stem 66, respectively. An intake valve spring 84 is compressed between the intake retainer 76 and an intake spring seat 80, and an exhaust valve spring 86 is compressed between the exhaust retainer 78 and an exhaust spring seat 82 on the cylinder head 6. The pressure generated by the intake valve spring 84 and the exhaust valve spring 86 is applied in a direction whereby the intake valve 64 seals off the intake port 36, and the exhaust valve 70 seals off the exhaust port 38 from the combustion chamber 14.

Referring to FIGS. 1 and 2, an intake camshaft 90 and an exhaust camshaft 92 are axially supported by multiple camshaft support structures 88 over the upper head surface 18 of the cylinder head 6 in parallel alignment in the lengthwise (L) direction. Each camshaft support structure 88 includes a first camshaft housing 94 which is installed to the upper head surface 18 oriented in the transverse (W) direction and aligned with the other first camshaft housings 94 at opposing sides of each cylinder 8 in the lengthwise direction (L), and a second camshaft housing 96 which is attached to each first camshaft housing 94, thus holding the camshaft 90 and the exhaust camshaft 92 there between. The camshaft support structure 88 is attached to the upper surface 18 of the cylinder head 6 by housing bolts 98.

The camshaft support structures 88, which axially support the intake and exhaust camshafts 90 and 92 between first and second camshaft housings 94 and 96, locate the intake camshaft 90 toward the outward extending side of the intake port 36, and the exhaust camshaft 92 toward the outward extending side of the exhaust port 38 in the transverse direction (W). An intake cam sprocket 100 and an exhaust cam sprocket 102 are respectively attached to the axial ends of the intake camshaft 90 and the exhaust camshaft 92, that extend forward past the front wall 20 of the cylinder head 6 ("F" direction of the engine 2).

The intake cam sprocket 100 and the exhaust cam sprocket 102 are driven by a timing chain (not shown in the drawings) that runs off of a sprocket on the crankshaft, and are covered by a chain case (not shown in the drawings)

6

attached to case mounting flanges 104 which extend outward in the transverse (W) direction from the front wall 20 of the cylinder head 6.

Moreover, a rear housing 106 is formed as an integral part of the first camshaft housing 94 nearest to rear wall 22 of cylinder head 6, and extends rearward (in the "R" direction of the engine 2) from the rear wall 22. An intake cam thrust receiver 108 (see FIG. 8) and an exhaust cam thrust receiver (not shown in the drawings) are installed around the rear extremities of the intake and the exhaust camshafts 90 and 92 that extend rearward from the rear housing 106 (in the "R" direction of the engine 2).

The intake camshaft thrust receiver mechanism 108 and the exhaust cam thrust receiver mechanism include an intake cam support member 114 and an exhaust cam support flange (the latter not shown in the drawings) which are pressed into the rear housing 106 around the respective rearward protruding ends of the intake and exhaust camshafts 90 and 92 (the latter not shown in FIG. 8) which extend outward from the rear housing 106. The intake cam support member 114 and the exhaust cam support flange are respectively located adjacent to an intake cam thrust bearing 112 and an exhaust cam thrust bearing (the latter not shown in the drawings) and the intake cam thrust washer 110 and an exhaust cam thrust washer (the latter not shown in the drawings). The intake cam thrust receiver mechanism 108 and the exhaust cam thrust receiver mechanism are provided to absorb axial thrust pressure from 3D intake and exhaust cams 116 and 118, respectively, (to be described subsequently), and thus prevent the intake and exhaust camshafts 90 and 92 from moving in the axial direction while rotating.

The variable valve mechanism 54 applied to the engine 2 includes camshafts which are axially supported by the cylinder head 6 and onto which 3D cams are formed with profiles that vary in the axial direction. At least one camshaft, onto which 3D cams are formed, is axially supported at the intake port 36 side of the cylinder head 6.

As illustrated in FIG. 1, the intake camshaft 90, which is axially supported on the intake port 36 side, is a single shaft incorporating four integrally formed 3D intake cams 116, one 3D intake cam 116 being located at each cylinder 8. Likewise, the exhaust camshaft 92, which is supported on the exhaust port 38 side, is a single shaft incorporating four integrally formed 3D exhaust cams 118, one 3D exhaust cam 118 being located at each cylinder 8. Each 3D intake cam 116 incorporates an axially varying lift profile that includes a maximum lift profile 116F and a minimum lift profile 116R, which are able to respectively actuate the intake valve 56 to a maximum and minimum lift volume respectively. Likewise, each 3D exhaust cam 118 incorporates an axially varying lift profile that includes a maximum lift profile 118F and a minimum lift profile 118R which actuate the exhaust valve 58 to a maximum and minimum lift volume, respectively.

The first camshaft housing 94 of the camshaft support structure 88 locates the intake camshaft 90 and the exhaust camshaft 92 in parallel alignment along opposing sides of the spark plug guide tubes 30 which are aligned along the center line of the cylinder head 6. An intake rocker shaft 120 and an exhaust rocker shaft 122 are movably supported in the axial direction, and fixedly supported in the radial direction. As can be seen in FIGS. 6 and 7, intake and exhaust rocker shaft actuators 124 and 126 are installed to the end of the rear housing 106 (direction "R") that extends rearward from the first camshaft housing 94 installed to the rear wall 22 of the cylinder head 6. The actuators 124 and

126 operate in response to engine conditions in order to set the axial positions of the intake and exhaust rocker shafts **120** and **122**, respectively.

As shown in FIGS. **6** through **8**, the intake and exhaust rocker shaft actuators **124** and **126** include a motor case **128** installed to the rear housing **106**, intake and exhaust rocker shaft male gear members **130** and **132**, respectively, which are integrally formed as male threads around the respective ends of the intake and exhaust rocker shafts **120** and **122**, and which extend into the motor case **128**. The intake and exhaust rocker shaft actuators **124** and **126** also include intake and exhaust rocker shaft female gear members **134** and **136**, respectively, which are formed as internally (female) threaded sleeves, movably supported by the motor case **128** in the radial direction but fixedly supported in the axial direction, whose female threads mesh with the male threads of the intake and exhaust rocker shaft male gear members **130** and **132**, respectively. The intake and exhaust rocker shaft actuators **124** and **126** further include intake and exhaust rocker shaft relay gears **138** and **140**, respectively, that radially extend from the circumference of the intake and exhaust rocker shaft female gear members **134** and **136**, respectively.

Further, the intake and exhaust rocker shaft actuators **124** and **126** include intake pinion gear **142** and an exhaust pinion gear (not shown in the drawings) that mesh with the intake and exhaust rocker shaft relay gears **138** and **140**, respectively, and include intake and exhaust (FIG. **1**) rocker shaft actuator motors **144** and **146**, respectively, which are installed to the motor case **128** and which drive the intake pinion gear **142** and the exhaust pinion gear, respectively.

The intake and exhaust rocker shaft actuators **124** and **126** provide a mechanism through which the intake and exhaust rocker shaft motors **144** and **146** are able to rotatably drive the intake and exhaust rocker shaft female gear members **134** and **136** through the intake pinion gear **142** and the exhaust pinion gear respectively driving intake and the exhaust rocker shaft relay gears **138** and **140**, thus axially displacing an intake rocker shaft **120** and an exhaust rocker shaft **122** through the respective rotational movements applied to the intake and exhaust rocker shaft male gear members **130** and **132**.

As shown in FIGS. **7** and **8**, in the interior of the motor case **128**, an intake cam sensor trigger **148** and an exhaust cam sensor trigger (not shown in the drawings), formed as integral components, are attached to the intake cam support member **114** and the exhaust cam support flange (not shown in the drawings) that attach to the ends of the intake and exhaust camshafts **90** and **92**, respectively, extending from the rear housing **106**. The intake cam sensor trigger **148** and the exhaust cam sensor trigger respectively activate intake and exhaust cam angle sensors **150** and **152** (FIG. **4**), respectively, which are installed to motor case **128**, to provide a cam position detection function.

As illustrated in FIGS. **3** through **6**, an intake valve lift volume setting mechanism **154**, which applies an amount of lift to the intake valves dependent on the axial position of the intake rocker shaft **120**, is located between the 3D intake cam **116** on the intake camshaft **90** and the intake valve stem tip **72** on the end of the intake valve **56**. In a similar structure, an exhaust valve lift volume setting mechanism **156**, which applies an amount of lift to the exhaust valves dependent on the axial position of the exhaust rocker shaft **122**, is located between the 3D exhaust cam **118** on the exhaust camshaft **92** and the exhaust valve stem tip **74** on the end of the exhaust valve **58**.

The intake valve lift volume setting mechanism **154** includes first intake rocker arm **158** whose fulcrum end is pivotably supported by and axially movable on the intake rocker shaft **120**, and whose non-fulcrum end contacts the intake valve stem tip **72**. The intake valve lift volume setting mechanism **154** further includes a second intake rocker arm **160** which contacts the first rocker arm **158**, and whose fulcrum end is pivotably supported by the intake rocker shaft **120**, but is not axially movable thereon.

The first intake rocker arm **158** is an approximately U-shaped member, positioned between adjacent first camshaft housings **94**, whose fulcrum end intersects with and is pivotably supported by the intake rocker shaft **120** while allowing the axial movement of the intake rocker shaft **120** therein. Two intake valve adjuster screws **162** are attached to the middle part of the first intake rocker arm **158** that runs parallel with the intake rocker arm shaft **120**, contact the intake valve stem tips **72**, and are secured by intake valve adjuster nuts **164**.

The second intake rocker arm **160** is a linear member located between the fulcrum ends of the U-shaped first intake rocker arm **158** and held in position on the intake rocker shaft **120** by stop flanges **166**. The second intake rocker arm **160** is thus able to radially pivot but not axially slide on the intake rocker shaft **120**. An intake roller **168**, which rides against the 3D intake cam **116**, is rotatably supported by and axially movable on the intake rocker shaft **170** which is attached to the center of each end of the U-shaped first intake rocker arm **158**.

An abbreviated description of the exhaust valve lift volume setting mechanism **156** will be offered, as mechanism **156** is structurally similar to the intake valve lift volume setting mechanism **154**. The exhaust valve lift volume setting mechanism **156** is an approximately U-shaped first exhaust rocker arm **172** and a straightly structured second exhaust rocker arm **174**. The fulcrum end of the first exhaust rocker arm **172** is pivotably supported by and axially movable on the exhaust rocker shaft **122**. The tip (non-fulcrum) end incorporates two exhaust valve adjuster screws **176** and corresponding exhaust valve adjuster nuts **178**. The fulcrum end of the second exhaust rocker arm **174** is pivotably supported by the exhaust rocker shaft **122** and is held in a fixed axial position thereon by stop flanges **180**. An exhaust roller **182**, which is the contacting member to the 3D exhaust cam **118**, is axially supported by exhaust roller shaft **184** whose ends are fixedly attached to the second exhaust rocker arm **174**.

The intake and exhaust valve lift volume setting mechanisms **154** and **156** provide a manner through which the amount of lift applied to the intake and exhaust valves **56** and **58** can be altered by changing the position where intake and exhaust rollers **168** and **182**, respectively, contact the profiles of 3D intake and exhaust cams **116** and **118**, respectively. The positions of the intake and exhaust rollers **168** and **182** can be changed by the mechanism through which the intake and exhaust rocker shaft actuators **124** and **126** move the intake and exhaust rocker shafts **120** and **122** in the axial direction.

As shown in FIGS. **1** and **4**, the variable valve mechanism **54** of the engine **2** axially supports the intake camshaft **90**, onto which the 3D intake cams **116** are formed, at least at the intake port **36** side of the cylinder head **6**. The fuel injector **40**, which sprays fuel into the intake port **36**, is installed to the part of the intake sidewall **24** bordering the intake port **36** of the cylinder head **6**. A concave part **186** is formed as a portion of the intake sidewall **24** that indents toward the intake camshaft **90** above the fuel injector **40**.

The concave part **186** is formed as an inwardly curved depression in the intake sidewall **24** at least at a location opposite to the harness connector **52** of the fuel injector **40**. The fuel injector **40** is installed to the intake sidewall **24** with the harness connector **52** inclined, with respect to the fuel injector casing **42**, in a direction away from the intake cam sprocket **100** (i.e. toward the rear (R) of the engine **2**) which is attached to the axial end of the intake camshaft **90**. The intake camshaft **90** is axially supported by the cylinder head **6** and oriented to place the maximum intake lift profile **116F** (which is the part of the 3D intake cam **116** that applies maximum valve lift) toward the front (F) of the engine **2** in respect to the minimum intake lift profile **116R** (which may apply zero lift), that is, on the side of the engine **2** nearer to the intake cam sprocket **100** which is attached to the end of the intake camshaft **90**.

The following discussion will explain the operation of the invention. The variable valve mechanism **54**, which is incorporated into the engine **2**, is able to vary the amount of lift applied to the intake and exhaust valves **56** and **58** by virtue of the intake and exhaust valve lift volume setting mechanisms **154** and **156** and the mechanism through which the intake and exhaust rocker shaft actuators **124** and **126** change the position of the intake and exhaust rocker arm shafts **120** and **122** in the axial direction, thus changing the positions of the intake and exhaust roller **168** and **182** on the profiles of the 3D intake and exhaust cam **116** and **118**, respectively.

The variable valve mechanism **54** provides for axial support of the intake camshaft **90**, onto which the 3D intake cams **116** are formed, at least on the intake port **36** side of the cylinder head **6**. The fuel injector **40**, which sprays fuel into the intake port **36**, is installed to the part of the intake sidewall **24** bordering the intake port **36** of the cylinder head **6**. The concave part **186** is formed within the portion of the intake sidewall **24** located above the fuel injector **40** and extends inwardly in a direction toward the intake camshaft **90**.

Thus structured, the variable valve mechanism **54** allows the fuel injector **40** to be installed to the intake sidewall **24** without obstruction as a result of the provision of the concave part **186**. As shown in FIG. 4, the fuel injector **40** can be located in closer proximity to the combustion chamber **14** in order to shorten distance "A" between the intake orifice **32** of the combustion chamber **14** and the nozzle **44** of the fuel injector **40**.

Even though the variable valve mechanism **54** provides for support of the intake camshaft **90** (onto which the 3D intake cams **116** are formed) at the intake port **36** side of the cylinder head **6**, this structure allows the fuel injector **40** to be placed at a location beneficial to combustion performance without increasing width "B" of the cylinder head **6**.

Moreover, as the variable valve mechanism **54** provides for at least the formation of the concave part **186** in the intake sidewall **24** opposite the harness connector **52** of the fuel injector **40**, the part of the intake sidewall **24** above the harness connector **52** and the fuel injector **40** may be formed to a shape that does not adversely affect the combustion performance of the cylinder head **6**.

Furthermore, the variable valve mechanism **54** provides for the installation of the fuel injector **40** to the intake sidewall **24** so that the harness connector **52** inclines away from the intake cam sprocket **100** which is installed to the axial end of the intake camshaft **90**, and further provides for the axial support of the intake camshaft **90** in the cylinder head **6** so that the maximum lift profile **116F**, which is the

part of the 3D intake cam **116** that provides the greatest amount of valve lift, is located nearer the intake cam sprocket **100** side of the intake camshaft **90**, the sprocket **100** being attached to the end of the intake camshaft **90**.

If the fuel injectors **40** were to be installed to the intake sidewall **24** with the harness connectors **52** inclined in a direction toward the intake sprocket **100** (i.e. toward the front of the engine **2**), the harness connector **52** on the forward-most fuel injector **40**, that is, the harness connector of the fuel injector installed to the part of the intake sidewall **24** nearest to the front wall **20** of the cylinder head **6**, would interfere with the case mounting flange **104** which protrudes outward in the transverse (W) direction from the front wall **20**. However, because the harness connector **52** is inclined toward the rear (direction "R") of the engine **2**, it does not interfere with the case mounting flange **104** nor the part of the intake sidewall **24** located above the harness connector **52** and the fuel injector **40**. Furthermore, by providing a gap between the minimum intake lift profile **116R** and the intake sidewall **24**, it becomes possible to form the concave part **186** in the intake sidewall **24** at a location opposing the harness connector **52** of the fuel injector **40**.

FIG. 9 describes a second embodiment of the invention. In this second embodiment of the variable valve mechanism **54**, the fuel injector **40** is installed to the intake sidewall **24** of the cylinder head **6**, the harness connector **52** is installed to the rearward end **48** of the fuel injector casing **42** of the fuel injector **40**, and the fuel rail **50** is installed to the rearward end **48** of the fuel injector casing **42** opposite to the intake sidewall **24**.

In this second embodiment of the variable valve mechanism **54**, the harness connector **52** and the fuel rail **50**, which are connected to the fuel injector casing **42** of the fuel injector **40**, are located farther away from the intake sidewall **24** as compared to their positions in the first embodiment, thus preventing the harness connector **52** and the fuel rail **50** from being obstructed by the intake sidewall **24** of the cylinder head **6**, and thus allowing distance "A" (the distance between the nozzle **44** of the fuel injector **40** and the intake orifice **32** of the combustion chamber **14**) to be reduced to a length shorter than that of the corresponding distance "A" in the first embodiment. The fuel injector **40** can thus be positioned closer to the combustion chamber **14**.

As a result, the second embodiment of the variable valve mechanism **54** makes it possible to install the fuel injector **40** at a location conducive to improved combustion performance without widening width "B" of the cylinder head **6**.

FIG. 10 describes a third embodiment of the invention. In this third embodiment of the variable valve mechanism **54**, the concave part **186** is formed as an angular depression extending inward toward the intake camshaft **90**, in the part of the intake sidewall **24** located above the fuel injector **40**, in order to reduce the width of gap "D" that extends along the profile of the 3D intake cam **116** from the maximum intake lift profile **116F** to the minimum intake lift profile **116R**.

In this third embodiment of the variable valve mechanism **54**, the concave part **186** is formed as an inward extending angular contour of the intake sidewall **24** at the fuel injector **40**. The concave part **186** reduces the width of gap "D" adjacent to the profile of the 3D intake cam **116**, and thus not only makes it possible to locate the fuel injector **40** nearer to the combustion chamber **14**, but to provide sufficient space between the intake sidewall **24** and the harness connector **52** of the fuel injector **40**.

11

As a result, the third embodiment of the variable valve mechanism 54 provides for easy installation of the harness connector 52 and allows for the placement of the fuel injector 40 at a location beneficial to combustion performance.

Although the invention has been described with reference to an exemplary embodiment, it is understood that the words that have been used are words of description and illustration, rather than words of limitation. Changes may be made, within the purview of the appended claims, as presently stated and as amended, without departing from the scope and spirit of the present invention in its aspects. Although the invention has been described herein with reference to particular means, materials and embodiments, the invention is not intended to be limited to the particulars disclosed herein. Instead, the invention extends to all functionally equivalent structures, methods and uses, such as are within the scope of the appended claims.

The present disclosure relates to subject matter contained in priority Japanese Application No. 2002-372285, filed on Dec. 24, 2002, which is herein expressly incorporated by reference in its entirety.

What is claimed is:

1. A variable valve mechanism for an internal combustion engine, comprising:

a camshaft, axially supported by an engine cylinder head, onto which a three-dimensional cam is formed to a profile that changes along the axial direction, said camshaft being axially supported at least on an intake port side of said cylinder head;

a rocker shaft actuator configured to change an axial position of a rocker shaft in response to engine operating conditions;

a valve lift volume setting mechanism configured to alter an amount of lift of a valve dependent on the extent of axial movement of said rocker shaft;

a fuel injector installed on a part of an intake sidewall bordering said intake port of said cylinder head, said fuel injector configured to spray fuel into an intake port; and

a concave part formed in said intake sidewall and extending inward toward said camshaft at a location above said fuel injector.

2. The variable valve mechanism according to claim 1, wherein said concave part is formed at least on a part of said intake sidewall directly opposite a fuel injector harness connector.

3. The variable valve mechanism according to claim 1, wherein said fuel injector is installed at said intake sidewall so as to incline said harness connector in a direction away from a sprocket attached to an axial end of said camshaft, and wherein said camshaft is axially supported by said cylinder head so that a maximum lift profile of said three-dimensional cam, said profile being the part of said cam that applies a maximum valve lift, is oriented toward an end of said camshaft to which said sprocket is attached.

4. A variable operating valve apparatus for an internal combustion engine, comprising:

a camshaft, axially supported by an engine cylinder head, said camshaft comprising a three-dimensional cam having a profile that varies along a length of said cam;

a rocker shaft having an axial position that changes in response to engine operating conditions;

a valve lift volume setting mechanism configured to alter the lift of a valve in response to an amount of axial movement of said rocker shaft; and

12

a fuel injector attached at an intake sidewall, said fuel injector configured to spray fuel into an intake port, wherein said intake sidewall comprises a concavity adjacent said fuel injector, said concavity formed as an inwardly curved depression in said intake sidewall and being configured to permit said fuel injector to be installed at said intake sidewall.

5. The variable operating valve apparatus according to claim 4, said concavity further comprising an angular depression extending inward in the direction of said camshaft.

6. The variable operating valve apparatus according to claim 4, wherein said concavity is formed opposite a connector associated with said fuel injector.

7. The variable operating valve apparatus according to claim 6, wherein said connector is angled away from a sprocket on said camshaft.

8. The variable operating valve apparatus according to claim 4, said camshaft further comprising a maximum lift profile portion that is oriented toward a sprocket end side of said camshaft.

9. A variable operating valve apparatus for an internal combustion engine, comprising:

a camshaft, axially supported by an engine cylinder head, said camshaft comprising a three-dimensional cam having a profile that varies along a length of said cam;

a rocker shaft having an axial position that changes in response to engine operating conditions;

a valve lift volume setting mechanism configured to alter the lift of a valve in response to an amount of axial movement of said rocker shaft; and

a fuel injector attached at an intake sidewall, said fuel injector configured to spray fuel into an intake port;

wherein said intake sidewall comprises a concavity adjacent said fuel injector, said concavity formed as an inwardly curved depression in said intake sidewall and being configured to permit said fuel injector to be installed at said intake sidewall; and

a connector and a fuel rail, each being associated with said fuel injector, and each being attached to a rearward end of a casing of said fuel injector.

10. The variable operating valve apparatus according to claim 9, wherein said connector and said fuel rail are unimpeded by said intake sidewall.

11. A variable operating valve apparatus for an internal combustion engine, comprising:

a camshaft, axially supported by an engine cylinder head, said camshaft comprising a three-dimensional cam having a profile that varies along a length of said cam;

a rocker shaft having an axial position that changes in response to engine operating conditions;

a valve lift volume setting mechanism configured to alter the lift of a valve in response to an amount of axial movement of said rocker shaft; and

a fuel injector attached at an intake sidewall, said fuel injector configured to spray fuel into an intake port,

wherein said intake sidewall comprises a concavity adjacent said fuel injector, said concavity permitting said fuel injector to be installed at said intake sidewall;

said concavity further comprising an angular depression extending inward in the direction of said camshaft.

13

12. A variable operating valve apparatus for an internal combustion engine, comprising:
a camshaft, axially supported by an engine cylinder head, said camshaft comprising a three-dimensional cam having a profile that varies along a length of said cam;
a rocker shaft having an axial position that changes in response to engine operating conditions;
a valve lift volume setting mechanism configured to alter the lift of a valve in response to an amount of axial movement of said rocker shaft; and

14

a fuel injector attached at an intake sidewall, said fuel injector configured to spray fuel into an intake port, wherein said intake sidewall comprises a concavity adjacent said fuel injector, said concavity permitting said fuel injector to be installed at said intake sidewall; wherein said concavity is formed opposite a connector associated with said fuel injector; and wherein said connector is angled away from a sprocket on said camshaft.

* * * * *

UNITED STATES PATENT AND TRADEMARK OFFICE
CERTIFICATE OF CORRECTION

PATENT NO. : 6,915,768 B2
DATED : July 12, 2005
INVENTOR(S) : H. Ohsawa

Page 1 of 1

It is certified that error appears in the above-identified patent and that said Letters Patent is hereby corrected as shown below:

Column 11,

Line 55, "cain" should be -- cam --.

Signed and Sealed this

Fourth Day of April, 2006

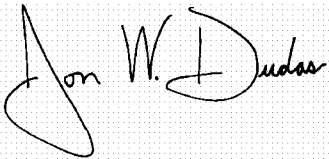
A handwritten signature in black ink on a light gray dotted background. The signature reads "Jon W. Dudas" in a cursive style. The "J" is large and loops around the "on". The "W" and "D" are also prominent.

JON W. DUDAS

Director of the United States Patent and Trademark Office