

J. B. BARRETT.
STEAM COOKING RANGE.
APPLICATION FILED APR. 18, 1907.

Fig. 1.

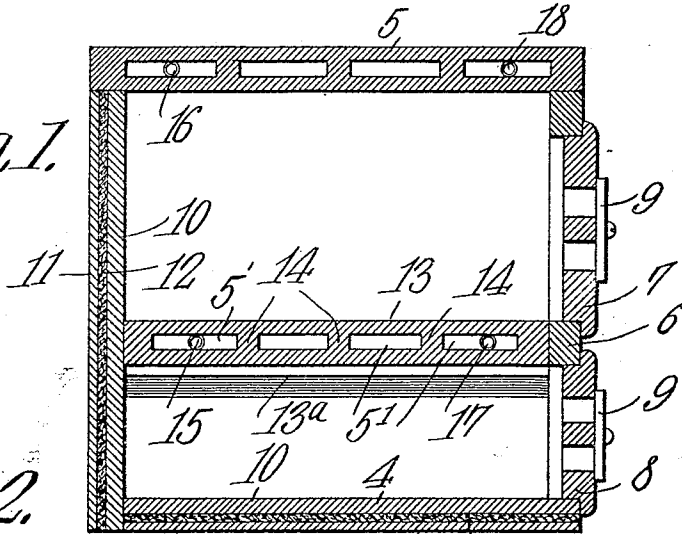

Fig. 2.

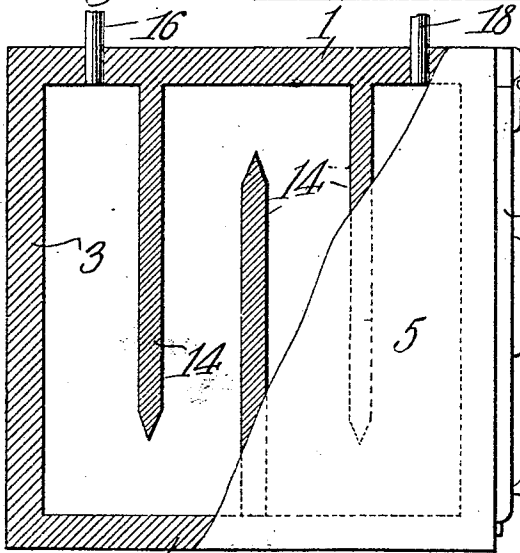

Fig. 3.

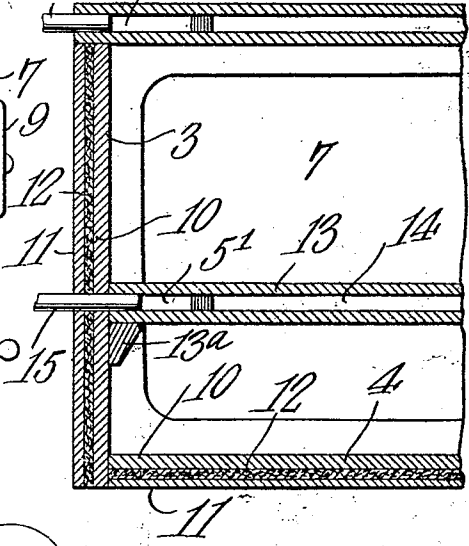
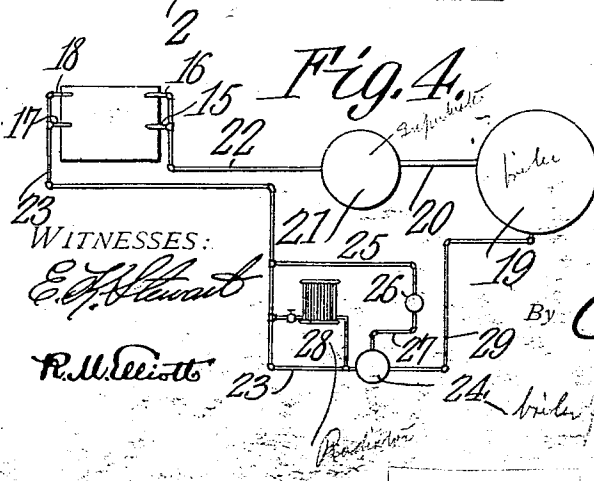
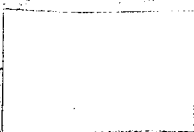

Fig. 4.



Jesse B. Barrett,
INVENTOR.
By *C. Snow & Co.*
ATTORNEYS



257
21

UNITED STATES PATENT OFFICE.

JESSE BRADLEY BARRETT, OF NIAGARA FALLS, NEW YORK.

STEAM COOKING-RANGE.

No. 878,449.

Specification of Letters Patent.

Patented Feb. 4, 1908.

Application filed April 18, 1907. Serial No. 368,936.

To all whom it may concern:

Be it known that I, JESSE BRADLEY BARRETT, a citizen of the United States, residing at Niagara Falls, in the county of Niagara and State of New York, have invented a new and useful Steam Cooking-Range, of which the following is a specification.

This invention relates to steam cooking ranges.

10 The object of the invention is in a novel and practical manner to employ low pressure superheated steam as a heating medium for a cooking range and to utilize the steam in such manner that practically all of the heat units will be conserved for doing effective work.

15 Furthermore, to provide a simple, novel and efficient form of range employing radiated heat from superheated steam as a cooking medium, that shall be adapted for baking, roasting or frying meats or other food stuffs and for cooking griddle and pan cakes, or for any other use to which an ordinary coal or gas range is put.

20 With the above and other objects in view as will appear as the nature of the invention is better understood, the same consists in the novel construction and combination of parts of a steam cooking range, as will be hereinafter fully described and claimed.

25 In the accompanying drawings forming a part of this specification and in which like characters of reference indicate corresponding parts, Figure 1 is a view in vertical longitudinal section. Fig. 2 is a top plan view partly in section, of the range. Fig. 3 is a vertical transverse section through the oven. Fig. 4 is a diagrammatic view exhibiting the manner in which the range is heated.

30 The range comprises, as usual, side walls 1 and 2, a back wall 3, a bottom 4, a top 5 and a front 6 with which is combined two doors 7 and 8 that may be solid or provided with dampers 9, as usual with constructions of this character.

35 In order to conserve the heat, the back, bottom and side walls are composed of three parts, these consisting of an inner plate 10, of cast or sheet iron, an outer plate 11 of the same material, and an interposed lining 12 of asbestos or any other suitable insulating material.

40 Arranged within the body or shell of the stove is a shelf or support 13 that is supported by ledges 13^a either secured to or formed integral with the side walls. This

shell is preferably made of cast iron, is hollow, and is provided interiorly with a series of baffles 14, which, as shown in Fig. 2, are arranged in staggered order, in order to present a series of tortuous ducts 5 through which steam will be forced to pass before escaping, thereby to retard its progress and thus insure the conservation of all of the heat units.

45 The top 5 of the range is constructed in the same manner as the shelf or support, and therefore the same reference characters will apply to both parts.

50 Steam is supplied to the support and top through pipes 15 and 16 arranged at one side of the parts, the steam being exhausted from the opposite side of the parts through pipes 17 and 18.

55 As stated, it is the object of the present invention to utilize low pressure superheated steam, the object for employing low pressure steam being that it is desired that the circulation through the support and top shall be relatively slow, thus to avoid noise, and also to insure proper utilization of the heat. The superheating of the steam may be effected in any preferred manner, one manner of securing this result being shown in Fig. 4 in which a boiler 19 is provided, from which the steam passes through a pipe 20 to a superheater 21 and thence through a pipe 22 to the range, connecting with the supply pipes 15 and 16. The exhaust pipes 17 and 18 leading from the range are connected to a return pipe 23 leading to a steam trap or pump 24 from which the condensed steam is forced back through a pipe 29 to the boiler 19. If desired other heating devices may take steam from the return pipe 23 and, after using its heat, return it to the steam trap 24, as for instance a secondary cooking apparatus or water heater 26, fed by a pipe 25 and having an exhaust pipe 27, or a steam radiator 28 receiving steam from the pipe 23 and returning it to the same pipe near the steam trap or pump.

60 Instead of taking steam from a boiler 19 it may be taken from an exhaust pipe or a steam supply pipe, and that the condensed steam may be delivered into a sewer or other drain instead of returning it to the boiler.

65 The top of the range is flat and may be finished to present a griddle upon which pan cakes or the like may be cooked, so that an extended surface is provided for this pur-

pose which will be evenly heated through-
out and will therefore possess advantages
over the ordinary form of gas stove in which
the heat is divided up into a plurality of
5 zones due to the arrangement of the burners.

By the provision of the tortuous ducts
formed by the baffles 14 the steam will be
retained a sufficient time to impart all its
effective heat to the top and shelf, but will
10 not be held back long enough to allow con-
densation which would be objectionable,
but even if this should occur the water of
condensation will be forced out through the
pipe 18 by the steam entering the pipe 16.

15 From the foregoing description it will be
seen that while the improvements herein
defined are simple in character, they will be
thoroughly effective for the purposes de-
signed, and that the ideas defined may be
20 carried out in an easy and practical manner.

What is claimed is:—

1. A range having heat insulated back,
sides and bottom, and a rectangular frame
front, a top plate, and an interior shelf divid-
25 ing the range into two ovens, the upper one
heated at the top and bottom and the lower
one heated only at the top, said top plate

and shelf each being a hollow closed struc-
ture having parallel baffles extending partly
across the structure and attached at one end 30
only, and alternately to opposite sides to
form a tortuous passage from end to end of
each structure, and steam supply and ex-
haust pipes, connected respectively to op-
posite ends of each tortuous passage. 35

2. A range having a top, and a horizontal
shelf dividing the oven into two parts said
top plate and shelf, each being a hollow
closed structure having interior parallel par-
titions extending alternately from one side 40
nearly to the other to form in each a tor-
tuous passage, and steam supply and ex-
haust pipes connected respectively to op-
posite ends of the tortuous passages, each
passage having separate inlet and outlet 45
pipes, said top plate and shelf radiating
from each side applied heat.

In testimony that I claim the foregoing
as my own I have hereto affixed my signa-
ture in the presence of two witnesses.

JESSE BRADLEY BARRETT.

Witnesses:

CHAS. H. SEIB,

GEORGE J. SCHUMACHER.