

(No Model.)

E. AYRES.

SYNCHRONIZING MECHANISM FOR ELECTRIC CLOCKS.

No. 525,779.

Patented Sept. 11, 1894.

FIG: 1.

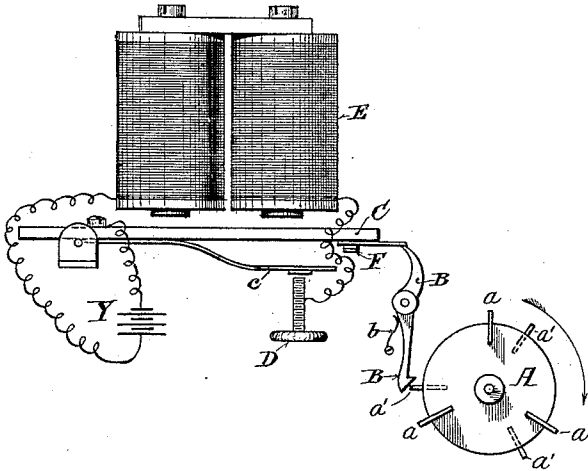

FIG: 2.

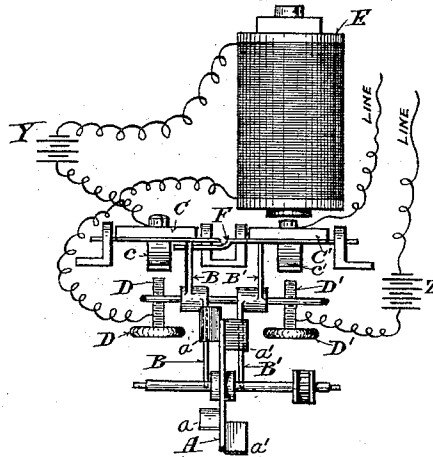

FIG: 3.

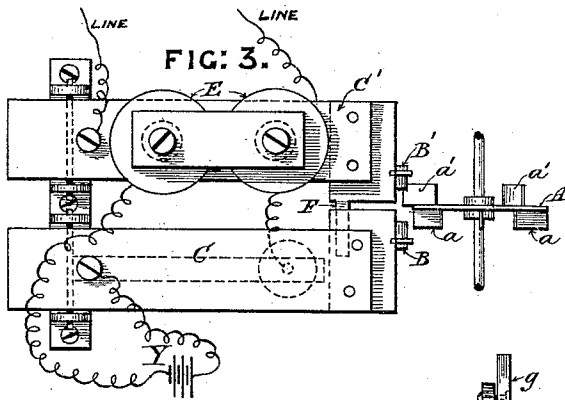

FIG: 4.

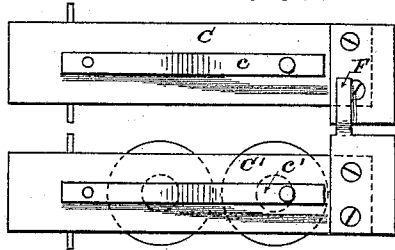

FIG: 5.

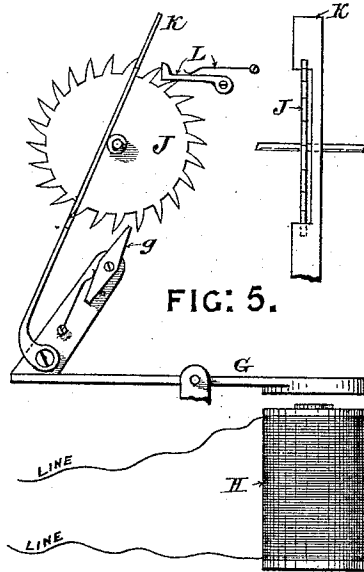
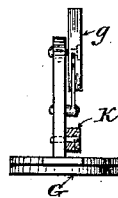

FIG: 7.



WITNESSES:

*N. J. Bell.*  
*D. H. Robertson.*

INVENTOR:

*Edgar Ayres*  
*by Partner & Co*  
*Attys*

# UNITED STATES PATENT OFFICE.

EDGAR AYRES, OF SYDNEY, NEW SOUTH WALES.

## SYNCHRONIZING MECHANISM FOR ELECTRIC CLOCKS.

SPECIFICATION forming part of Letters Patent No. 525,779, dated September 11, 1894.

Application filed October 7, 1893. Serial No. 487,406. (No model.)

*To all whom it may concern:*

Be it known that I, EDGAR AYRES, a subject of the Queen of Great Britain, residing in Sydney, in the Colony of New South Wales, have invented certain new and useful Improvements in Apparatus for Operating Clocks Synchronously; and I do hereby declare the following to be a full, clear, and exact description of the invention, such as will enable others skilled in the art to which it appertains to make and use the same, reference being had to the accompanying drawings, and to letters of reference marked thereon, which form a part of this specification.

This invention consists mainly of two parts, first of appliances for alternately completing and breaking an electric circuit that controls the second part of the invention, namely, the apparatus for moving other clocks synchronously.

In the accompanying drawings:—Figure 1 is a front elevation of the apparatus for making and breaking circuit. Fig. 2 is an end elevation of the same. Fig. 3 is a plan view from above. Fig. 4 is a plan view from below. Fig. 5 is a front view of the appliances, used for giving motion to the synchronous clocks. Fig. 6 is a detail end view of the escapement. Fig. 7 is a detail end view of the lever that moves the escapement wheel, but with the part shown in Fig. 6 removed.

A is a disk that is mounted on any suitable spindle or shaft in the primary or regulating clock, and is provided with two sets of radial vanes or tappets, one set *a* is secured on one face of the disk at regular intervals, and the other set *a'* is secured on the other face of the disk at regular intervals but in advance of the first set *a*, the distance between the two sets of tappets being fixed according to the time that it is desired to keep the operating electric circuit closed. Each set of vanes *a a'* act as tappets to actuate triggers B B' that can be moved independently of one another. The normal position of the triggers is shown in Fig. 1, and they may be caused to resume that position after being moved, by any suitable means or appliance, such, for instance, as the small spring *b*. Each trigger when in its normal position, will support a pivoted or hinged arm C C'. The arm C carries on its under side a tongue *c*, which, when the trig-

ger B is moved and the pivoted arm C is allowed to fall, will come in contact with a contact point or screw D, and close a local circuit shown on the drawings as Y. Included in this local circuit is an electro-magnet E, the armature of which constitutes a pivoted arm C'. The arm C', also carries a tongue *c'*, on its under side, a contact point or screw D' being provided as is the case with the other pivoted arm. When the armature C' falls, when released by the trigger B', the line circuit Z will be closed. The armature C' is provided with a plate F, that projects sufficiently far to underlie the pivoted arm C, see Fig. 4.

The mode in which the above described apparatus operates is as follows:—The disk A as it rotates will cause each tappet *a'* to successively impinge against the lower end of the trigger B'. When a tappet moves the trigger, it will free the armature C', and allow it to fall and close the line circuit Z as before mentioned. As the disk A revolves, the following tappet *a* on the opposite side will move the trigger B, thereby releasing the arm C and allowing it to fall and close the local circuit Y. The armature C' will then be immediately lifted by the electro-magnet E, and by means of the projecting plate F, the arm C will be lifted with the armature and both circuits Y, Z broken. Both the armature C', and the arm C, are lifted sufficiently high to set themselves again on their respective triggers B B'.

The special object of the disk A and tappet *a a'* device is to minimize the time of action of the intermittent current of the line circuit, and thus render the adoption of primary batteries possible for this purpose.

The apparatus that gives motion to each synchronous clock, consists of a pivoted lever G, one end of which is the armature of an electro-magnet H which is included in the line circuit. The other end of the lever, projects obliquely upward, and is provided at its extremity with a pivoted spring finger *g*. This finger *g*, engages with the teeth of a ratchet wheel J, and every time the lever G, is moved, the wheel J is moved the distance of one tooth. When the lever G resumes its normal position the spring finger *g*, will give way and allow it to pass the next succeeding tooth. In order to prevent the wheel J being pushed round more than one tooth an escape-

ment is used. This escapement consists of a plate K, that is attached to the lever G, and is recessed or slotted to receive the ratchet wheel J. See Fig. 6. The plate K engages alternately at the top and bottom, with the teeth of the ratchet wheel, every time that lever G is moved. Thus, when the lever is in its normal position, the escapement plate K is in engagement with an upper tooth while the bottom is free from the teeth. When the lever is moved, the bottom of the recess in the plate K will engage with a bottom tooth and the top will be free. By this arrangement it will be seen that the ratchet wheel can only be moved a fixed distance of one tooth. A spring pawl L, is employed to prevent the wheel J from moving backward when the lever G falls.

As before described the line circuit Z is closed and opened at regular intervals. Each time the circuit is closed the electro-magnet H, of each clock will be brought into action and motion be imparted to each clock in circuit, synchronously with the primary.

Having thus described my invention, what I claim, and desire to secure by Letters Patent, is—

1. In apparatus for operating clocks synchronously, a pair of pivoted arms or levers one of which constitutes the armature of an electro-magnet, each being provided with contact points or means for closing an electric circuit, the armature lever or arm having a lateral extension which underlies the other arm, whereby when the armature is attracted by the magnet it shall be caused to lift the

other arm and break the circuits, as herein described.

2. In apparatus for operating clocks synchronously, in combination, a disk that is provided with tappets at regular intervals apart on both its faces, a pair of triggers that are controlled by the tappets, a pair of pivoted arms or levers, one of which constitutes the armature of an electro-magnet, each arm being provided with means for closing an electric circuit and one being provided with means whereby both arms shall be lifted simultaneously when the armature is attracted by the electro-magnet as herein set forth.

3. In electric clocks that are operated synchronously from a primary, in combination, a rocking lever one arm of which constitutes the armature of an electro-magnet, the circuit in which it is placed being controlled by a primary clock, the other arm of the rocking lever being provided with a spring actuated finger that engages with and moves a toothed wheel every time the armature is attracted and a check or escapement plate secured to that lever whereby the motion of the toothed wheel is controlled as herein described.

In witness whereof I have hereunto signed my name in the presence of two subscribing witnesses.

EDGAR AYRES.

Witnesses:

THOMAS ORMOND O'BRIEN,  
Notary Public, Sydney, New South Wales.  
PERCIVAL NEWTON,  
Elizabeth St., Sydney, N. S. Wales.